

## FOREWORD

This manual contains an introductory description on the SUZUKI LT-Z50 and procedures for its inspection/service and overhaul of its main components. Other information considered as generally known is not included.

Read the GENERAL INFORMATION section to familiarize yourself with the vehicle and its maintenance. Use this section as well as other sections to use as a guide for proper inspection and service.

This manual will help you know the vehicle better so that you can assure your customers of fast and reliable service.

\* This manual has been prepared on the basis of the latest specifications at the time of publication. If modifications have been made since then, differences may exist between the content of this manual and the actual vehicle.

\* Illustrations in this manual are used to show the basic principles of operation and work procedures. They may not represent the actual vehicle exactly in detail.

\* This manual is written for persons who have enough knowledge, skills and tools, including special tools, for servicing SUZUKI vehicles. If you do not have the proper knowledge and tools, ask your authorized SUZUKI motorcycle dealer to help you.

### **▲ WARNING**

**Inexperienced mechanics or mechanics without the proper tools and equipment may not be able to properly perform the services described in this manual. Improper repair may result in injury to the mechanic and may render the vehicle unsafe for the rider.**

## SUZUKI MOTOR CORPORATION

© COPYRIGHT SUZUKI MOTOR CORPORATION 2005

## GROUP INDEX

**GENERAL INFORMATION**

**1**

**PERIODIC MAINTENANCE**

**2**

**ENGINE**

**3**

**FUEL SYSTEM**

**4**

**CHASSIS**

**5**

**ELECTRICAL SYSTEM**

**6**

**SERVICING INFORMATION**

**7**

**PartShark.com**  
**877-999-5686**

# SUPPLEMENTS

*LT-Z50K9 ( 09-MODEL)*

**8**

PartShark.com  
877-999-5686

## HOW TO USE THIS MANUAL TO LOCATE WHAT YOU ARE LOOKING FOR:

1. The text of this manual is divided into sections.
2. The section titles are listed in the GROUP INDEX.
3. Holding the manual as shown at the right will allow you to find the first page of the section easily.
4. The contents are listed on the first page of each section to help you find the item and page you need.

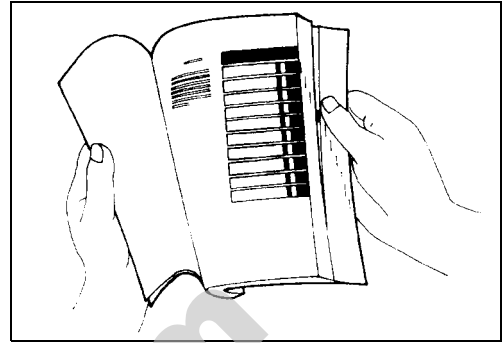

## COMPONENT PARTS AND WORK TO BE DONE

Under the name of each system or unit, is its exploded view. Work instructions and other service information such as the tightening torque, lubricating points and locking agent points, are provided.

Example: Front and rear wheel

①	Front tire
②	Front wheel
③	Rear tire
④	Rear wheel
Ⓐ	Wheel set nut (front & rear)





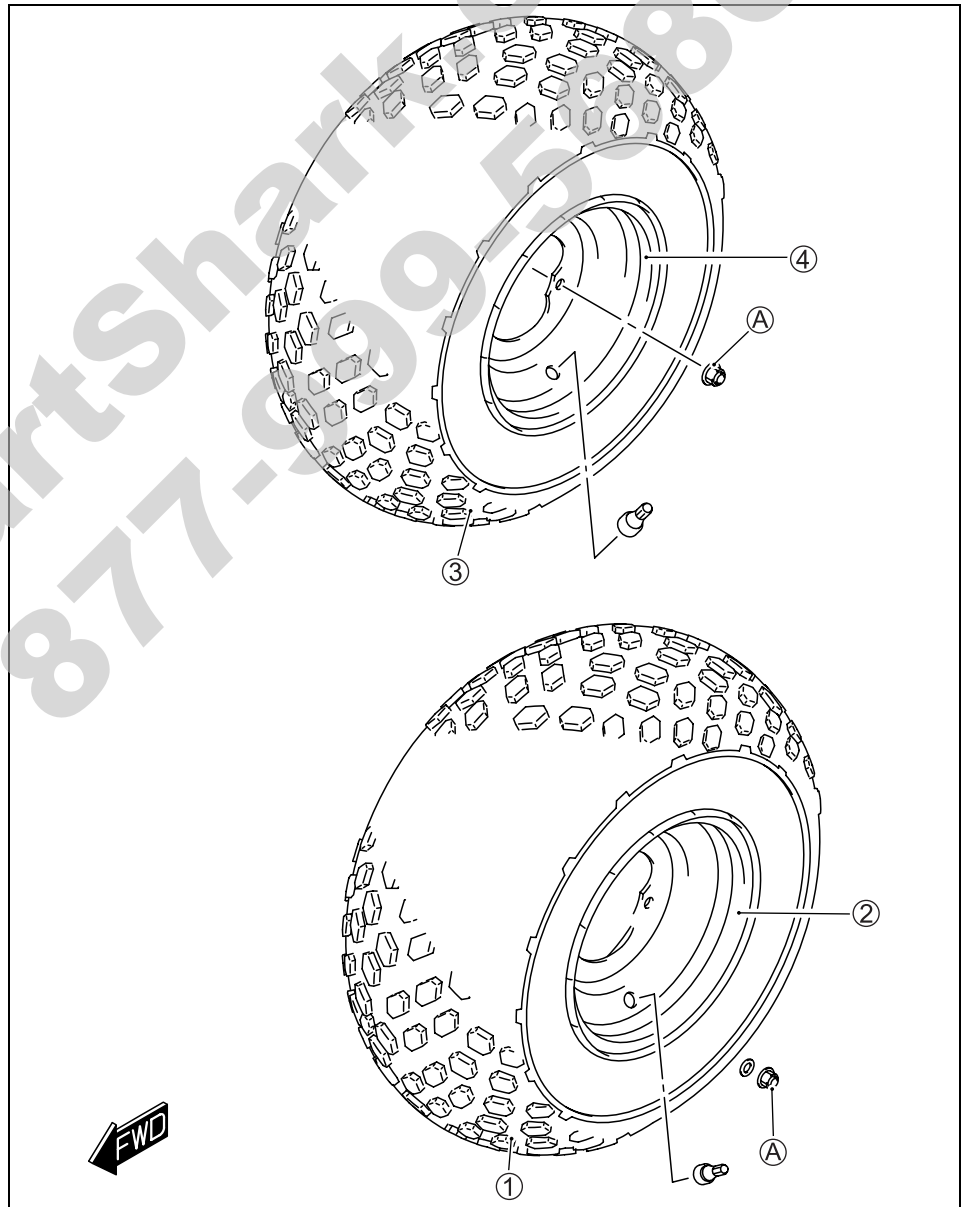







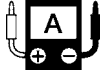



ITEM	N·m	kgf·m	lb·ft
Ⓐ	28	2.8	20.0



## SYMBOL

Listed in the table below are the symbols indicating instructions and other information necessary for servicing. The meaning of each symbol is also included in the table.

SYMBOL	DEFINITION	SYMBOL	DEFINITION
	Torque control required. Data beside it indicates specified torque.		Measure in voltage range.
	Apply oil. Use engine oil unless otherwise specified.		Measure in current range.
	Apply molybdenum oil solution. (mixture of engine oil and SUZUKI MOLY PASTE in a ratio of 1 : 1)		Measure in resistance range.
	Apply SUZUKI SUPER GREASE "A" or equivalent. 99000-25010		Measure in diode test range.
	Apply SUZUKI MOLY PASTE or equivalent. 99000-25140		Measure in continuity test range.
	Apply WATER RESISTANCE GREASE or equivalent. 99000-25161		Use special tool.
	Apply SUZUKI BOND "1215" or equivalent. 99000-31110		Indication of service data.
	Apply THREAD LOCK "1342" or equivalent. 99000-32050		

# GENERAL INFORMATION

1

## CONTENTS

<b>WARNING/CAUTION/NOTE .....</b>	<b>1- 2</b>
<b>GENERAL PRECAUTIONS.....</b>	<b>1- 2</b>
<b>SUZUKI LT-Z50K6 ('06-MODEL).....</b>	<b>1- 4</b>
<b>SERIAL NUMBER LOCATION.....</b>	<b>1- 4</b>
<b>FUEL AND OIL RECOMMENDATION .....</b>	<b>1- 5</b>
<b>FUEL (FOR USA AND CANADA).....</b>	<b>1- 5</b>
<b>FUEL (FOR OTHER COUNTRIES).....</b>	<b>1- 5</b>
<b>ENGINE OIL AND FINAL REDUCTION GEAR BOX OIL</b>	
<b>(FOR USA) .....</b>	<b>1- 5</b>
<b>ENGINE OIL AND FINAL REDUCTION GEAR BOX OIL</b>	
<b>(FOR OTHER COUNTRIES) .....</b>	<b>1- 5</b>
<b>BREAK-IN PROCEDURES .....</b>	<b>1- 6</b>
<b>INFORMATION LABELS.....</b>	<b>1- 7</b>
<b>INFORMATION MARKS.....</b>	<b>1- 7</b>
<b>SPECIFICATIONS .....</b>	<b>1- 8</b>
<b>DIMENSIONS AND DRY MASS .....</b>	<b>1- 8</b>
<b>ENGINE .....</b>	<b>1- 8</b>
<b>DRIVE TRAIN.....</b>	<b>1- 8</b>
<b>CHASSIS.....</b>	<b>1- 9</b>
<b>ELECTRICAL .....</b>	<b>1- 9</b>
<b>CAPACITIES.....</b>	<b>1- 9</b>

## COUNTRY AND AREA CODES

The following codes stand for the applicable country (-ies) and area (-s).

MODEL	CODE	COUNTRY or AREA	EFFECTIVE FRAME NO.
LT-Z50K6	P-03	U.S.A.	LM4AZ413 61100001-
	P-19	E.U.	
	P-28	Canada	

## WARNING/CAUTION/NOTE

Please read this manual and follow its instructions carefully. To emphasize special information, the symbol and the words WARNING, CAUTION and NOTE have special meanings. Pay special attention to the messages highlighted by these signal words.

### **⚠ WARNING**

Indicates a potential hazard that could result in death or injury.

### **CAUTION**

Indicates a potential hazard that could result in vehicle damage.

### *NOTE:*

*Indicates special information to make maintenance easier or instructions clearer.*

Please note, however, that the warnings and cautions contained in this manual cannot possibly cover all potential hazards relating to the servicing, or lack of servicing, of the vehicle. In addition to the WARNINGS and CAUTIONS stated, you must use good judgement and basic mechanical safety principles. If you are unsure about how to perform a particular service operation, ask a more experienced mechanic for advice.

## GENERAL PRECAUTIONS

### **⚠ WARNING**

- \* Proper service and repair procedures are important for the safety of the service mechanic and the safety and reliability of the vehicle.
- \* When 2 or more persons work together, pay attention to the safety of each other.
- \* When it is necessary to run the engine indoors, make sure that exhaust gas is forced outdoors.
- \* When working with toxic or flammable materials, make sure that the area you work in is well-ventilated and that you follow all of the material manufacturer's instructions.
- \* Never use gasoline as a cleaning solvent.
- \* To avoid getting burned, do not touch the engine, engine oil, final reduction gear box oil and exhaust system until they have cooled.
- \* After servicing the fuel or exhaust systems, check all lines and fittings related to the system for leaks.

**CAUTION**

- \* If parts replacement is necessary, replace the parts with Suzuki Genuine Parts or their equivalent.
  - \* When removing parts that are to be reused, keep them arranged in an orderly manner so that they may be reinstalled in the proper order and orientation.
  - \* Be sure to use special tools when instructed.
  - \* Make sure that all parts used in reassembly are clean. Lubricate them when specified.
  - \* Use the specified lubricant, bond, or sealant.
  - \* When removing the battery, disconnect the negative cable first and then the positive cable.
  - \* When reconnecting the battery, connect the positive cable first and then the negative cable, and replace the terminal cover on the positive terminal.
  - \* When performing service to electrical parts, if the service procedures do not require use of battery power, disconnect the negative cable from the battery.
  - \* When tightening the cylinder head or case bolts and nuts, tighten the larger sizes first. Always tighten the bolts and nuts diagonally from the inside toward outside and to the specified tightening torque.
  - \* Whenever you remove oil seals, gaskets, packing, O-rings, locking washers, self-locking nuts, cotter pins, circlips and certain other parts as specified, be sure to replace them with new ones. Also, before installing these new parts, be sure to remove any left over material from the mating surfaces.
  - \* Never reuse a circlip. When installing a new circlip, take care not to expand the end gap larger than required to slip the circlip over the shaft. After installing a circlip, always ensure that it is completely seated in its groove and securely fitted.
  - \* Use a torque wrench to tighten fasteners to the specified torque. Wipe off grease and oil if a thread is smeared with them.
  - \* After reassembling, check parts for tightness and proper operation.
- 
- \* To protect the environment, do not unlawfully dispose of used motor oil: batteries and tires.
  - \* To protect Earth's natural resources, properly dispose of used vehicle and parts.



## SUZUKI LT-Z50K6 ('06-MODEL)



RIGHT SIDE



LEFT SIDE

- Difference between photograph and actual vehicle may exist depending on the markets.

## SERIAL NUMBER LOCATION

The frame serial number or V.I.N. (Vehicle Identification Number) ① is stamped on the left side of the rear frame pipe. The engine serial number ② is located on the right side of the generator case. These numbers are required especially for registering the machine and ordering spare parts.

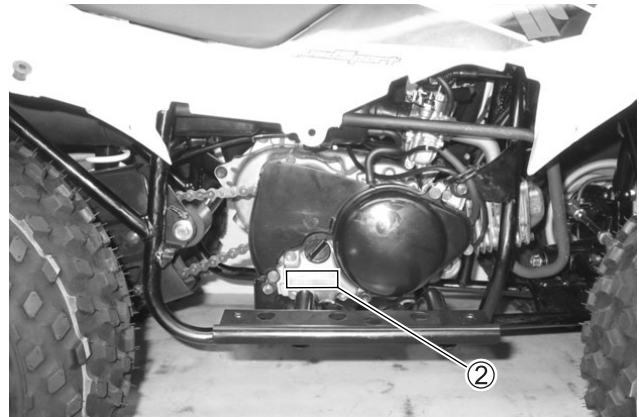

## FUEL AND OIL RECOMMENDATION

### FUEL (FOR USA AND CANADA)

Use only unleaded gasoline of at least 87 pump octane (R/2 + M/2) or 91 octane or higher rated by the Research Method.

Gasoline containing MTBE (Methyl Tertiary Butyl Ether), less than 10 % ethanol, or less than 5 % methanol with appropriate cosolvents and corrosion inhibitor is permissible.

### FUEL (FOR OTHER COUNTRIES)

Gasoline used should be graded 91 octane (Research Method) or higher. Unleaded gasoline is recommended.

### ENGINE OIL AND FINAL REDUCTION GEAR BOX OIL (FOR USA)

Oil quality is a major contributor to your engine's performance and life. Always select good quality engine oil. Suzuki recommends the use of SUZUKI PERFORMANCE 4 MOTOR OIL or equivalent engine oil. Use of API SF/SG or SH/SJ with JASO MA.

Suzuki recommends the use of SAE 10W-40 engine oil. If SAE 10W-40 engine oil is not available, select an alternative according to the following chart.

### ENGINE OIL AND FINAL REDUCTION GEAR BOX OIL (FOR OTHER COUNTRIES)

Oil quality is a major contributor to your engine's performance and life. Always select good quality engine oil. Use of API SF/SG or SH/SJ with JASO MA.

Suzuki recommends the use of SAE 10W-40 engine oil. If SAE 10W-40 engine oil is not available, select an alternative according to the right chart.

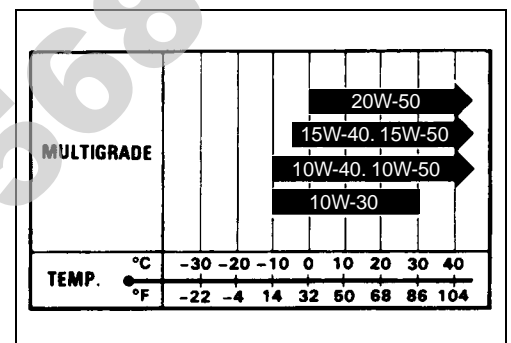

## **BREAK-IN PROCEDURES**

During manufacture only the best possible materials are used and all machined parts are finished to a very high standard but it is still necessary to allow the moving parts to “BREAK-IN” before subjecting the engine to maximum stresses. The future performance and reliability of the engine depends on the care and restraint exercised during its early life. Refer to the following throttle position recommendations.

- Keep to these break-in throttle position:

### **Brake-in engine speeds**

**Up to 10 hours: Less than 1/2 throttle**

PartShark.com  
877-999-5686

## INFORMATION LABELS

① Certification plate	A (For P-03, 19)
② Compliance label	A (For P-28)
③ Manual notice label	A (For P-03)
④ Parking brake label (English)	A (For P-03, 19, 28)
⑤ Parking brake label (French)	A (For P-28)
⑥ Tire air pressure and warning no-passenger label (English)	A (For P-03, 19, 28)
⑦ Tire air pressure and warning no-passenger label (French)	A (For P-28)
⑧ General warning & AGE 6 label (English)	A (For P-03, 19, 28)
⑨ General warning label (French)	A (For P-28)
⑩ AGE 6 label (French)	A (For P-28)
⑪ EC mark label	A (For P-19)
⑫ ICES Canada label	A (For P-28)
⑬ Information label	A (For P-03)
⑭ Approval label	A (For P-19)

A: Attached

## INFORMATION MARKS

Ⓐ No passenger mark (English)	(For P-03, 19, 28)
Ⓑ No passenger mark (French)	(For P-28)

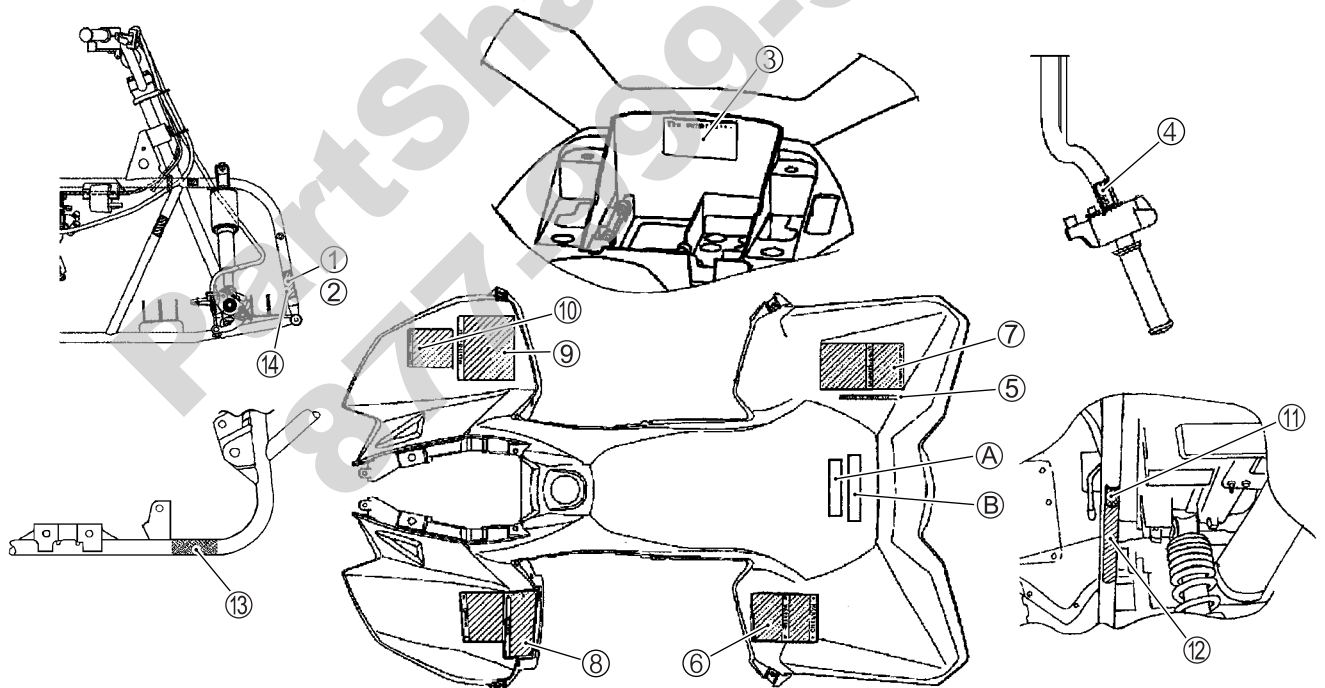

⑭ Label is attached on the left side of frame.

**SPECIFICATIONS****DIMENSIONS AND DRY MASS**

Overall length.....	1 270 mm (50.0 in)
Overall width.....	760 mm (29.9 in)
Overall height.....	765 mm (30.1 in)
Wheelbase.....	830 mm (32.7 in)
Ground clearance.....	120 mm (4.7 in)
Seat height.....	535 mm (21.1 in)
Front track.....	575 mm (22.6 in)
Rear track.....	575 mm (22.6 in)
Dry mass.....	76 kg (167 lbs)

**ENGINE**

Type.....	Four stroke, air-cooled, OHV
Number of cylinders.....	1
Bore.....	36.0 mm (1.417 in)
Stroke.....	48.6 mm (1.913 in)
Displacement.....	49 cm <sup>3</sup> (3.0 cu.in)
Compression ratio.....	8.4:1
Carburetor.....	MIKUNI VM13, single
Air cleaner.....	Polyurethane foam element
Starter system.....	Electric and recoil starter
Idle speed.....	2 000 ± 150 r/min

**DRIVE TRAIN**

Reduction ratio.....	2.091 – 1.879 (Variable change)
Reduction gear ratio.....	4.272 (47/11)
Final reduction ratio.....	3.700 (37/10)
Drive chain.....	D.I.D. 415, 82 links

**CHASSIS**

Front suspension.....	Independent, swing axle, coil spring, oil damped
Rear suspension .....	Swingarm, coil spring, oil damped
Front wheel travel.....	52 mm (2.0 in)
Rear wheel travel .....	51 mm (2.0 in)
Caster.....	3 °
Trail .....	10 mm (0.39 in)
Toe-in .....	1.5 ± 3 mm (0.06 ± 0.12 in)
Camber .....	0 °
Steering angle .....	35 °
Turning radius .....	2.0 m (6.6 ft)
Front brake.....	Drum brake
Rear brake .....	Drum brake
Front tire size .....	AT16 × 8 – 7☆, tubeless
Rear tire size .....	AT16 × 8 – 7☆, tubeless

**ELECTRICAL**

Ignition type.....	Electronic ignition (CDI)
Ignition timing.....	20 ° B.T.D.C. at 4 600 r/min
Spark plug .....	NGK CR6HSA or DENSO U20FSR-U
Battery.....	12 V 14.4 kC (4 Ah)/10 HR
Main fuse.....	10 A

**CAPACITIES**

Fuel tank .....	2.6 L (0.7/0.6 US/Imp gal)
Engine oil, oil change.....	300 ml (0.6/0.5 US/Imp qt)
overhaul .....	350 ml (0.7/0.6 US/Imp qt)
Final reduction gear box oil, oil change.....	25 ml (0.8/0.9 US/Imp oz)
overhaul .....	30 ml (1.0/1.1 US/Imp oz)

These specifications are subject to change without notice.

**PartShark.com**  
**877-999-5686**

# PERIODIC MAINTENANCE

## CONTENTS

<b>PERIODIC MAINTENANCE SCHEDULE .....</b>	<b>2- 2</b>
<b>PERIODIC MAINTENANCE CHART .....</b>	<b>2- 2</b>
<b>MAINTENANCE AND TUNE-UP PROCEDURES .....</b>	<b>2- 3</b>
<b>AIR CLEANER .....</b>	<b>2- 3</b>
<b>EXHAUST PIPE NUTS AND MUFFLER MOUNTING BOLT .....</b>	<b>2- 5</b>
<b>VALVE CLEARANCE .....</b>	<b>2- 5</b>
<b>SPARK PLUG .....</b>	<b>2- 7</b>
<b>SPARK ARRESTER .....</b>	<b>2- 8</b>
<b>FUEL LINE .....</b>	<b>2- 8</b>
<b>ENGINE OIL .....</b>	<b>2- 9</b>
<b>FINAL REDUCTION GEAR BOX OIL .....</b>	<b>2-10</b>
<b>THROTTLE CABLE PLAY .....</b>	<b>2-10</b>
<b>ENGINE IDLE SPEED .....</b>	<b>2-11</b>
<b>DRIVE BELT .....</b>	<b>2-11</b>
<b>DRIVE CHAIN .....</b>	<b>2-14</b>
<b>BRAKES .....</b>	<b>2-17</b>
<b>TIRES .....</b>	<b>2-18</b>
<b>STEERING .....</b>	<b>2-19</b>
<b>SUSPENSIONS .....</b>	<b>2-19</b>
<b>CHASSIS NUTS AND BOLTS .....</b>	<b>2-20</b>
<b>GENERAL LUBRICATIONS .....</b>	<b>2-22</b>
<b>COMPRESSION PRESSURE CHECK .....</b>	<b>2-23</b>
<b>COMPRESSION TEST PROCEDURE .....</b>	<b>2-23</b>
<b>INITIAL ENGAGEMENT AND CLUTCH LOCK-UP INSPECTION .....</b>	<b>2-24</b>
<b>INITIAL ENGAGEMENT INSPECTION .....</b>	<b>2-24</b>
<b>CLUTCH LOCK-UP INSPECTION .....</b>	<b>2-25</b>



## PERIODIC MAINTENANCE SCHEDULE

The chart below lists the recommended intervals for all the required periodic service work necessary to keep the vehicle operating at peak performance and economy.

**NOTE:**

*More frequent servicing may be required on vehicles that are used under severe conditions.*

### PERIODIC MAINTENANCE CHART

Item	Interval	Initial 1 month	Every 3 months	Every 6 months
Air cleaner element		—	C	C
Exhaust pipe nuts and muffler mounting bolt		T	T	T
Valve clearance		I	—	I
Spark plug		—	—	I
		Replace every 18 months.		
Spark arrester		—	C	C
Fuel line		—	I	I
		Replace every 4 years.		
Engine oil		R	—	R
		Inspect each time the vehicle is ridden.		
Final reduction gear box oil		—	—	I
		Replace every 2 years.		
Throttle cable play		I	I	I
Idle speed		I	I	I
Drive belt		—	I	R
Drive chain		Clean, lubricate and inspect each time the vehicle is ridden.		
Brakes		I	I	I
Tires		Inspect every month.		
Steering		I	I	I
Suspensions		—	—	I
Chassis nuts and bolts		T	T	T
General lubrications		—	L	L

**NOTE:**

*I = Inspect and clean, adjust, replace, or lubricate as necessary.*

*R = Replace*

*T = Tighten*

*C = Clean*

*L = Lubricate*

## MAINTENANCE AND TUNE-UP PROCEDURES

This section describes the servicing procedures for each item of the periodic maintenance requirements.

Before performing the servicing procedures mentioned in the periodic maintenance chart, remove following parts to ease servicing work;

- Seat. (☞5-4)
- Front frame cover. (☞5-4)
- Left frame cover. (☞5-4)
- Right frame cover. (☞5-4)
- Frame center cover. (☞5-5)
- Maintenance lid. (☞5-6)
- Front grip. (☞5-6)

### AIR CLEANER

**Clean every 3 months.**

If the air cleaner is clogged with dust, intake resistance will be increase, resulting in a decrease in engine output and an increase in fuel consumption. Clean the air cleaner element in the following manner.

- Remove the seat. (☞5-4)
- Remove the battery holder. (☞5-5)
- Remove the air cleaner box cap ①.
- When installing the air cleaner box cap ①, face the “UP” mark to the top.
- Remove the air cleaner element ②.

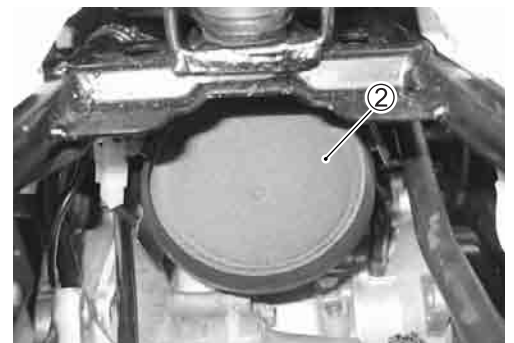
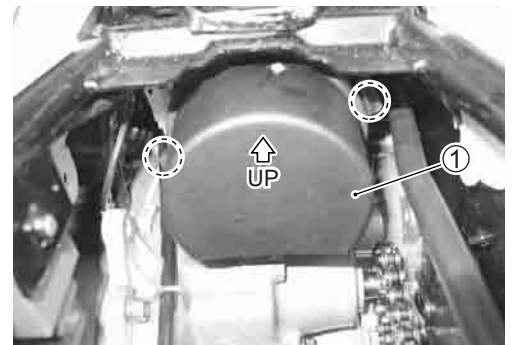

- Fill a container with a non-flammable cleaning solvent.
- Immerse the air cleaner element in the cleaning solvent and wash it.
- Squeeze the cleaning solvent out of the washed element by pressing it between the palms of both hands: do not twist or wring the element or it will develop tears.
- Immerse the element in motor oil and squeeze the oil out of the element leaving it slightly wet with oil.

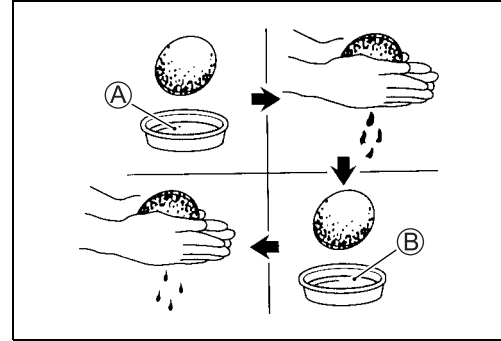

**CAUTION**

**Inspect the air cleaner element for tears. A torn element must be replaced.**

- Ⓐ Non-flammable cleaning solvent
- Ⓑ Motor oil SAE #30

- Reinstall the cleaned air cleaner element in the reverse order of removal.
- When installing the air cleaner box cap ①, face the “UP” mark to the top.

**CAUTION**

**Be sure to position the element snugly and correctly, so that no incoming air will by-pass it. Remember, the rapid wear of piston rings and the cylinder bore is often caused by a defective or poorly fitted element.**

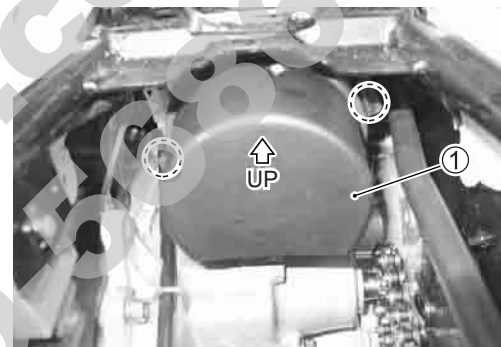

**CAUTION**

**If driving under dusty conditions, clean the air cleaner element more frequently. The surest way to accelerate engine wear is to operate the engine without the element or to use a torn element. Make sure that the air cleaner is in good condition at all times. The life of the engine depends largely on this component!**

## EXHAUST PIPE NUTS AND MUFFLER MOUNTING BOLT

Tighten initially at 1 month and every 3 months thereafter.

- Tighten the exhaust pipe nuts ① and muffler mounting bolt ② to the specified torque.

**Exhaust pipe nut:** 10 N·m (1.0 kgf·m, 7.0 lb-ft)  
**Muffler mounting bolt:** 23 N·m (2.3 kgf·m, 16.5 lb-ft)

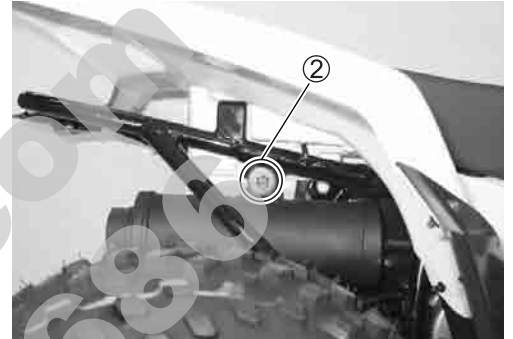
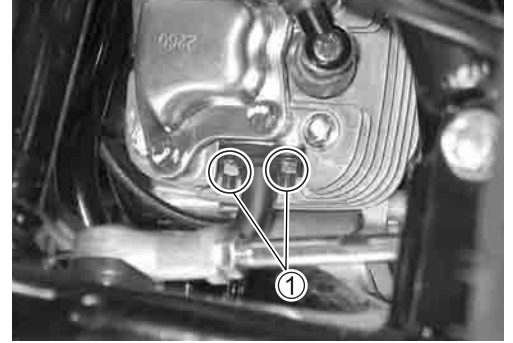

## VALVE CLEARANCE

Inspect initially at 1 month and every 6 months thereafter.

Excessive valve clearance results in valve noise and insufficient valve clearance results in valve damage and reduced power. Check the intake and exhaust valve clearances at the interval indicated above and adjust the valve clearances to specification, if necessary.

- Remove the right frame cover. (☞ 5-4)
- Remove the spark plug. (☞ 2-7)
- Remove the cylinder head cover ①.
- Remove the generator rotor cover ②.

### NOTE:

- \* Valve clearance is to be checked when the engine is cold.
- \* The intake and exhaust valves must be checked and adjusted when the piston is at Top-Dead-Center (TDC) of the compression stroke.

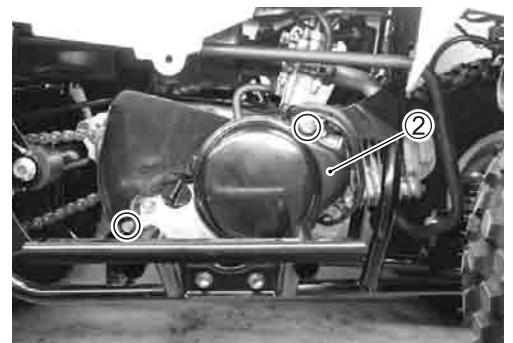
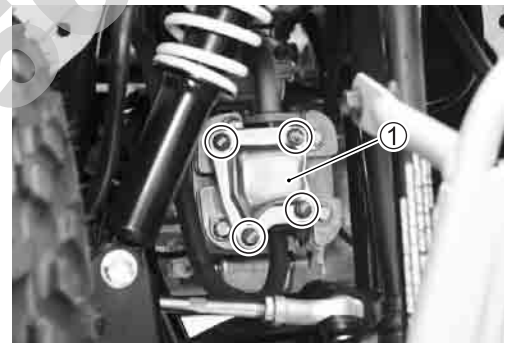

- Turn the crankshaft counterclockwise, to bring the line (A) on the generator rotor to the index mark (B) of the generator case.

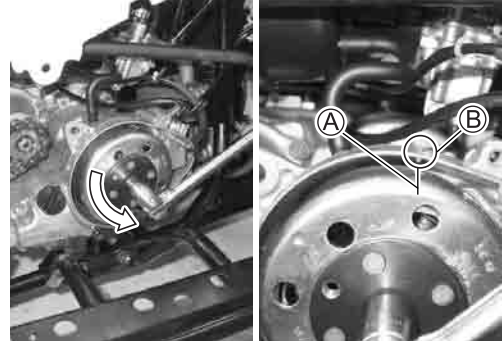

- Press intake and exhaust rocker arm to the inside and measure the valve clearance.

**TOOL** 09900-20806: Thickness gauge

**DATA** Valve clearance (when cold):  
 IN: 0.05 – 0.10 mm (0.002 – 0.004 in)  
 EX: 0.10 – 0.15 mm (0.004 – 0.006 in)

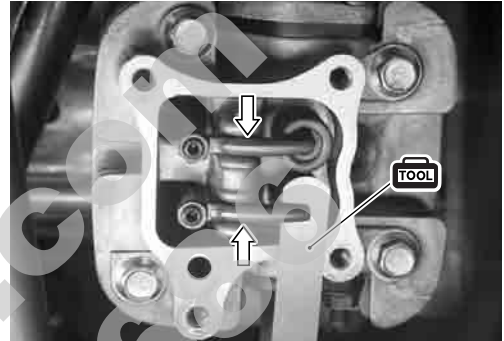

- If the clearance is out of specification, adjust it to the specified range with a special tool and 2.5 mm hexagon wrench (3).

**TOOL** Valve clearance adjuster locknut (4):  
 7 N·m (0.7 kgf-m, 5.0 lb-ft)

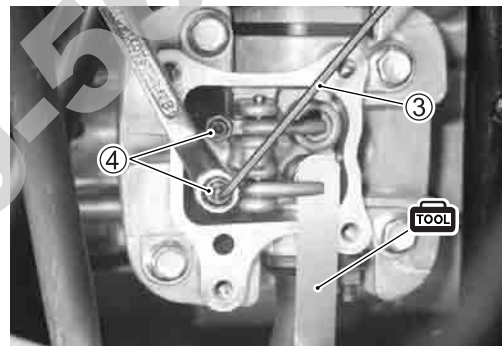

- Tighten the cylinder head cover (1) to the specified torque.

**TOOL** Cylinder head cover bolt: 11 N·m (1.1 kgf-m, 8.0 lb-ft)

- Install the removed parts.

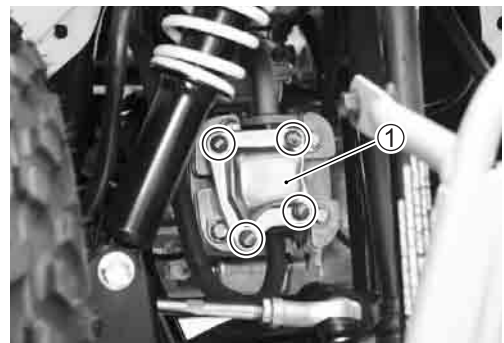

## SPARK PLUG

**Inspect every 6 months.  
Replace every 18 months.**

- Disconnect the spark plug cap ① and remove the spark plug ②.

	Standard	Cold type
NGK	CR6HSA	CR7HSA
DENSO	U20FSR-U	U22FSR-U

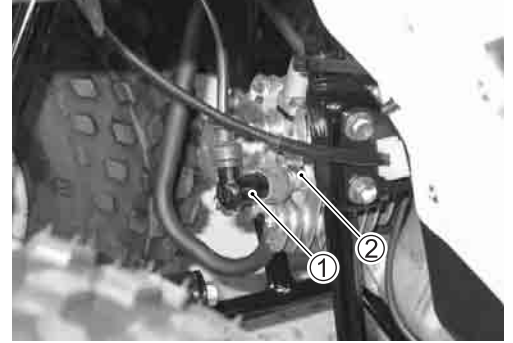

### CARBON DEPOSITS

Check carbon deposits on the spark plug.

- If carbon is deposited, remove it using a spark plug cleaner machine or carefully use a tool with a pointed end.

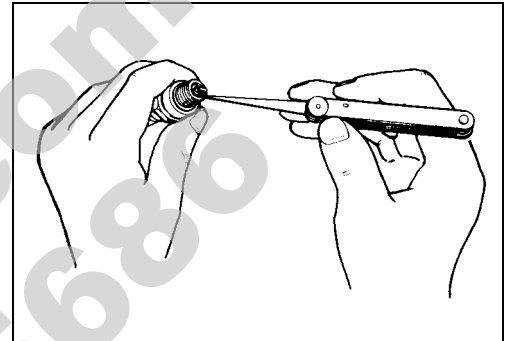

### SPARK PLUG GAP

Measure the spark plug gap with a thickness gauge.

- Adjust the spark plug gap if necessary.

**DATA** Spark plug gap:  
Standard: 0.6 – 0.7 mm (0.024 – 0.028 in)

**TOOL** 09900-20803: Thickness gauge

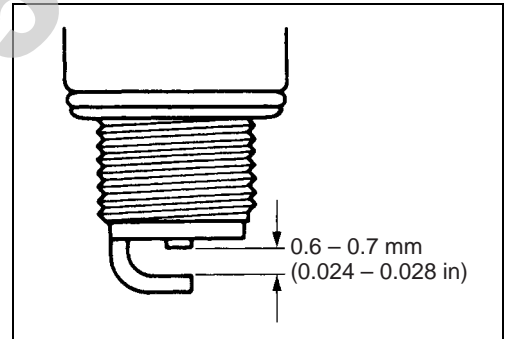

### ELECTRODE'S CONDITION

Check the condition of the electrode.

If it is extremely worn or burnt, replace the spark plug.

- Replace the spark plug if it has a broken insulator, damaged thread, etc.

### CAUTION

**Confirm the thread size and reach when replacing the plug. If the reach is too short, carbon will be deposited on the screw portion of the plug hole and engine damage may result.**



## SPARK PLUG INSTALLATION

### CAUTION

To avoid damaging the cylinder head threads; first, tighten the spark plug by hand and then tighten it to the specified torque using the spark plug wrench.

- Tighten the spark plug to the specified torque.

 Spark plug: 11 N·m (1.1 kgf·m, 8.0 lb·ft)



## SPARK ARRESTER

Clean every 3 months.

- Extract the spark arrester ① from the muffler.

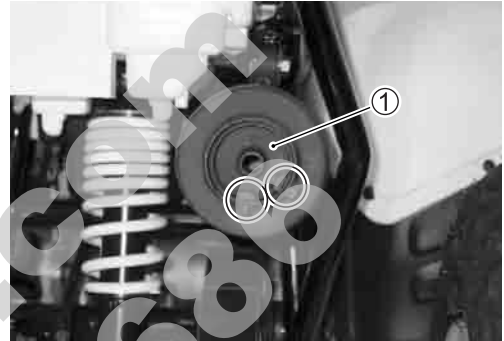

- Clean the spark arrester ① by brush.
- Reinstall the spark arrester ①.

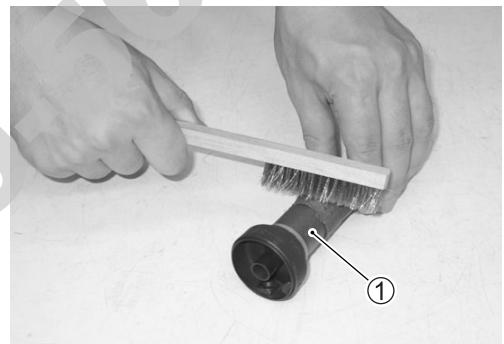

## FUEL LINE

Inspect every 3 months.  
Replace every 4 years.

Inspect the fuel hose for damage and fuel leakage. If any defects are found, replace it with a new one.

- When replacing the fuel hose, remove the left frame cover.  5-4



## ENGINE OIL

**Inspect each time the vehicle is ridden.  
Replace initially 1 month and every 6 months thereafter.**

### ENGINE OIL LEVEL CHECK

Follow the procedure below to inspect the engine oil level.

- Place the vehicle on level ground.
- Remove the maintenance lid. (☞ 5-6)
- Start the engine and run it for a few minutes.
- Stop the engine and wait three minutes.
- Check the engine oil level with the engine oil dipstick ①.

### CAUTION

- \* Check the engine oil level with the dipstick ① before each time the vehicle is ridden.
- \* Be sure the engine oil level is always between the "L" (low) line and the "F" (full) line.

- Install the filler cap ② securely.

### ENGINE OIL REPLACEMENT

The oil should be changed while the engine is warm.

- Place the vehicle on level ground.
- Remove the maintenance lid. (☞ 5-6)
- Place an oil pan under the engine oil drain plug ①, and then drain out the engine oil by removing the engine oil drain plug ① and engine oil filler cap ②.
- Tighten the engine oil drain plug ①, with the new washer, to the specified torque, and then pour the new oil through the oil filler hole. When performing an oil change, the engine will hold about 300 ml (0.6/0.5 US/Imp qt) of oil. Use API SF/SG or SH/SJ with JASO MA.

### Engine oil drain plug: 12 N·m (1.2 kgf-m, 8.5 lb-ft)

- Check the engine oil level above.

### Engine oil capacity:

**Oil change: 300 ml (0.6/0.5 US/Imp qt)**

**Overhaul: 350 ml (0.7/0.6 US/Imp qt)**

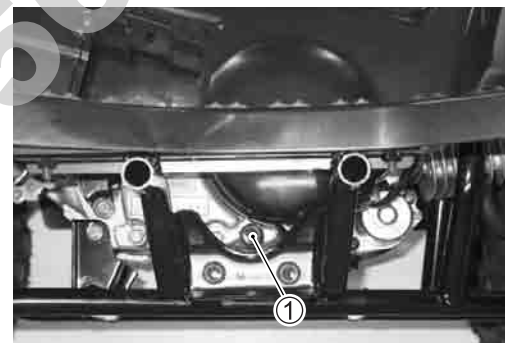
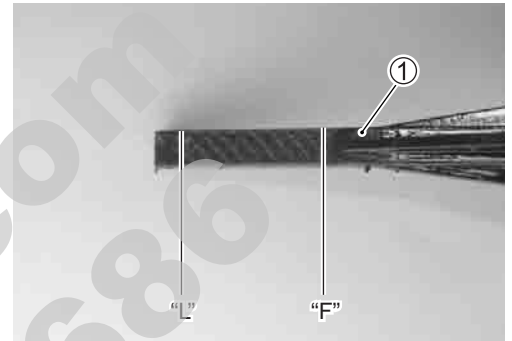
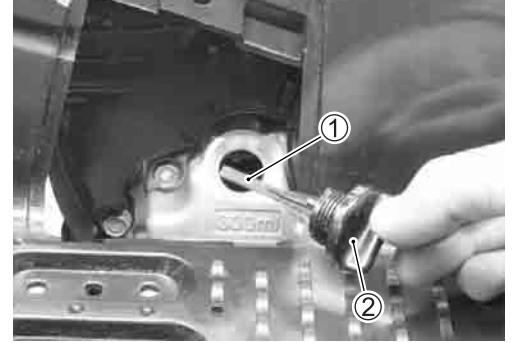



## FINAL REDUCTION GEAR BOX OIL

Inspect every 6 months.  
Replace every 2 years.

### FINAL REDUCTION GEAR BOX OIL LEVER CHECK

- Place the vehicle on level ground.
- Remove the right frame cover. (☞ 5-4)
- Remove the generator cover ①.
- Remove the oil filler cap ②.
- Inspect the oil level. If the oil level is below the edge of the oil filler hole, add oil until it flows from the filler hole.

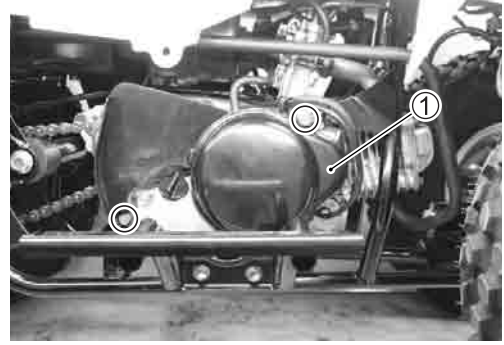

### FINAL REDUCTION GEAR BOX OIL REPLACEMENT

- Place the vehicle on level ground.
- Remove the right frame cover. (☞ 5-4)
- Remove the generator cover ①.
- Remove the oil filler cap ②.
- Remove the drain plug ③ and drain the oil into an oil pan.
- Reinstall the drain plug ③.
- Pour new oil through the oil filler hole until the oil flows from oil filler hole.
- Reinstall the oil filler cap ②.

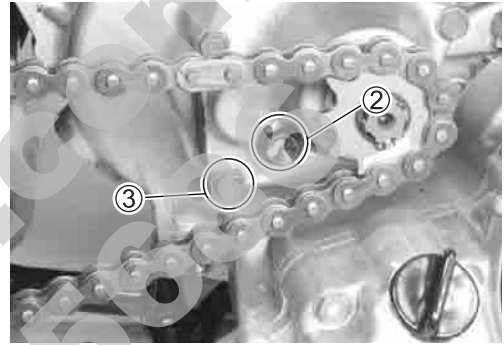

**DATA** Final reduction gear box oil capacity:  
Oil change: 25 ml (0.8/0.9 US/Imp oz)  
Overhaul: 30 ml (1.0/1.1 US/Imp oz)



## THROTTLE CABLE PLAY

Inspect initially at 1 month and every 3 months thereafter.

Adjust the throttle cable play ① as follows.



- Loosen the lock-nut ① of the throttle cable.
- Turn the adjuster ② in or out to obtain the correct play.
- After adjusting the throttle cable play, tighten the locknut ①.

**DATA** Throttle cable play: 3 – 5 mm (0.12 – 0.20 in)

**⚠ WARNING**

After the adjustment is completed, check that handlebar movement does not raise the engine idle speed and that the throttle lever returns smoothly and automatically.

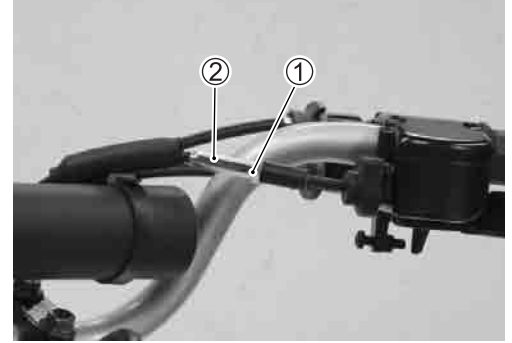

## ENGINE IDLE SPEED

Inspect initially at 1 month and every 3 months thereafter.

- Adjust the throttle cable play. (☞ 2-10)
- Warm up the engine.

**NOTE:**

Make this adjustment when the engine is hot.

- Start the engine, turn the throttle stop screw ① and set the engine idle speed as follows.

**DATA** Engine idle speed: 2 000 ± 150 r/min.

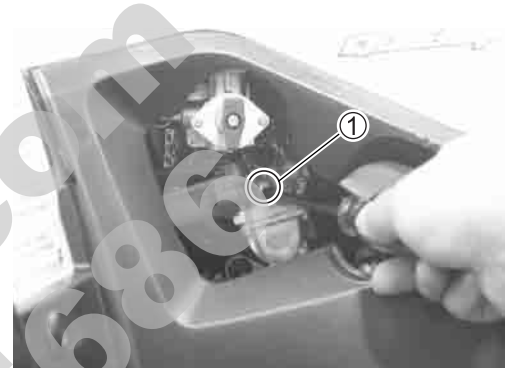

## DRIVE BELT

Inspect every 3 months.  
Replace every 6 months.

**REMOVAL**

- Remove the left frame cover. (☞ 5-4)
- Remove the left footrest ①.
- Remove the CVT case cover ②.

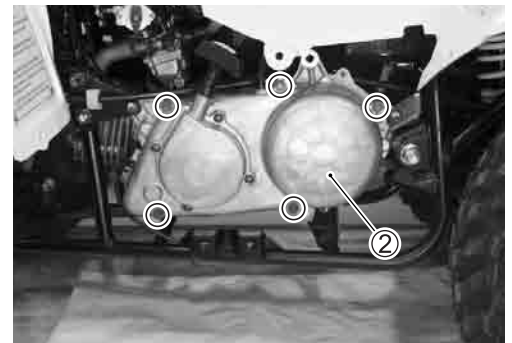
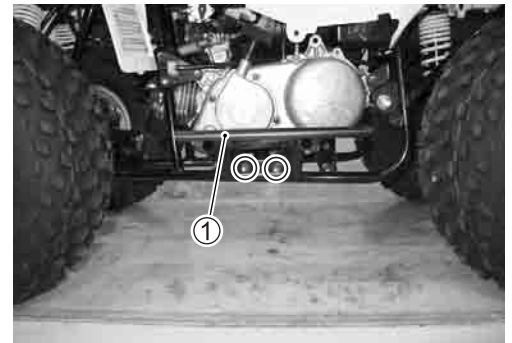

- Remove the fixed drive face nut ③ and starter cup ④ with the special tool.

 09930-40113: Rotor holder

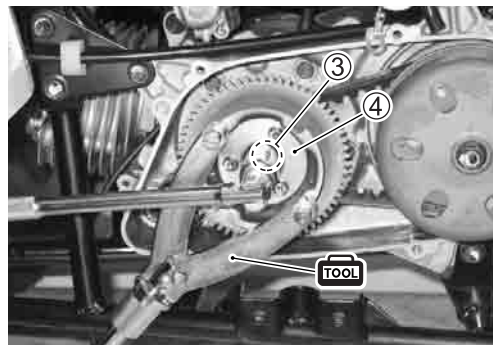

- Remove the fixed drive face ⑤.

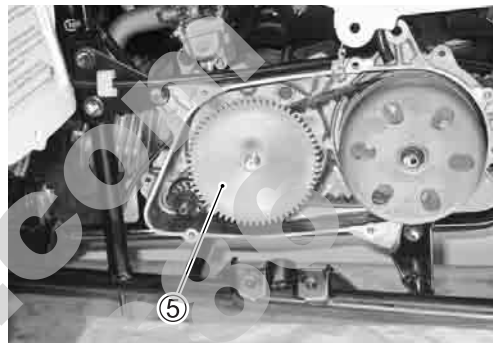

- Remove the clutch housing ⑥ with the special tool.

 09930-40113: Rotor holder

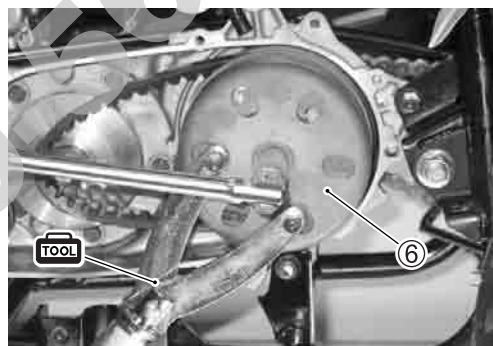

- Remove the movable driven face ⑦ with drive belt ⑧.

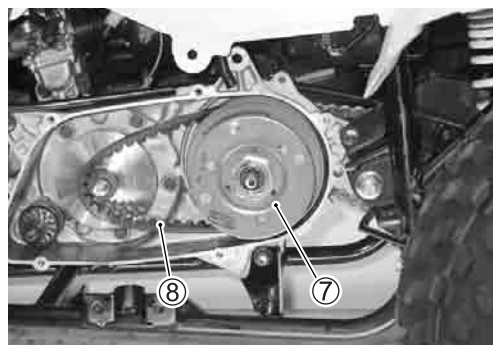

### INSPECTION

Inspect the drive belt for wear and damage. If any cracks or defects are found, replace it with a new one.

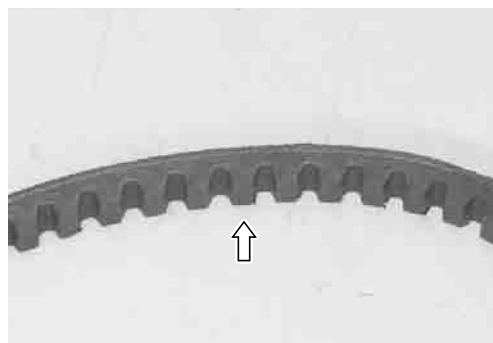

**REMountING**

Remount the drive belt in the reverse order of removal. Pay attention to the following points:

- Insert the drive belt, as low as possible, between the movable driven face to provide the maximum drive belt clearance before installing.
- Install the movable driven face with drive belt.

**CAUTION**

- \* Fit the drive belt to the movable driven face so that the arrows on the drive belt outer surface aim toward normal turning direction.
- \* The drive belt contact surface of the driven face should be thoroughly cleaned.

**NOTE:**

Degrease the movable drive face assembly. Use non-flammable cleaning solvent to wipe off oily or greasy matter and make its surfaces completely dry.



- Tighten the clutch housing nut to the specified torque with the special tool.

**TOOL** 09930-40113: Rotor holder

**TOOL** Clutch housing nut: 50 N·m (5.0 kgf·m, 36.0 lb·ft)

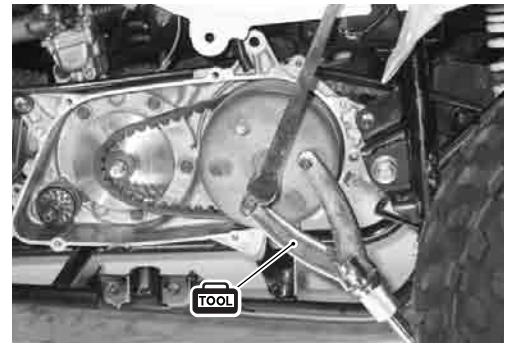

- Tighten the fixed drive face nut to the specified torque with the special tool.

**TOOL** 09930-40113: Rotor holder

**TOOL** Fixed drive face nut:

Initial: 13 N·m (1.3 kgf·m, 9.5 lb·ft)

Final: 50 N·m (5.0 kgf·m, 36.0 lb·ft)

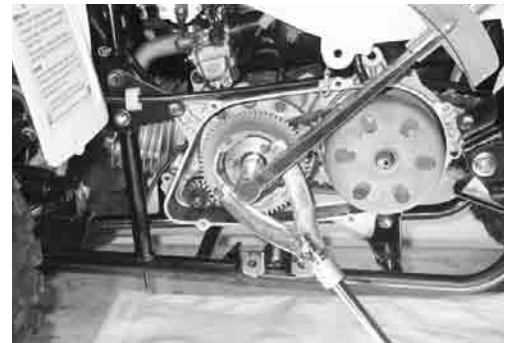

- Turn the fixed drive face until the drive belt is properly seated and both the drive and driven face rotate together smoothly and without slipping.

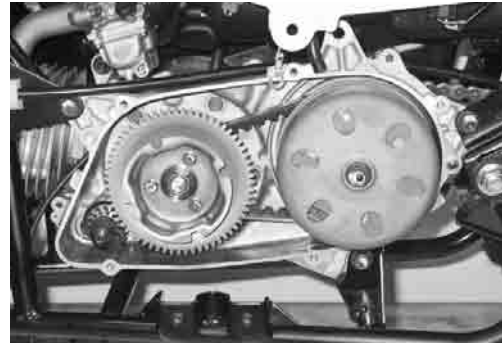

## DRIVE CHAIN

**Clean, lubricate and inspect each time the vehicle is ridden.**

Visually check the drive chain for the possible defects listed below. (Support the vehicle by a jack and a wooden block, turn the rear wheel slowly by hand.)

- |                   |                           |
|-------------------|---------------------------|
| * Loose pins      | * Twisted or seized links |
| * Damaged rollers | * Excessive wear          |
| * Rusted links    | * Kinked or binding links |

If any defects are found, the drive chain must be replaced.

### CAUTION

**The standard drive chain is D.I.D. 415. SUZUKI recommends to use this standard drive chain as a replacement.**

### NOTE:

*When replacing the drive chain, replace the drive chain and sprockets as a set.*

### CHECKING

- Loosen the bolts ①.
- Tense the drive chain fully by turning both chain adjusters ②.

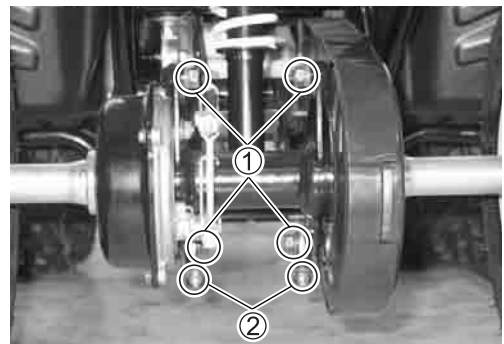



- Count out 21 pins (20-pitch) on the chain and measure the distance between the two points. If the distance exceeds the service limit, the chain must be replaced.

**DATA** Drive chain 20-pitch length:  
 Service limit: 259.0 mm (10.20 in)

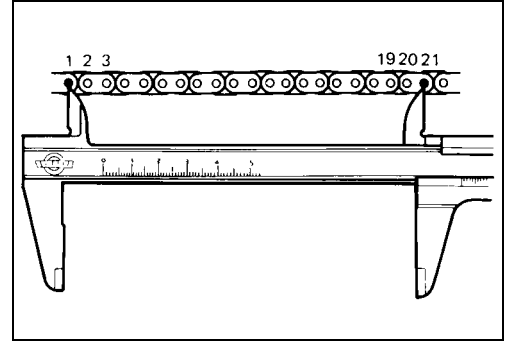

**ADJUSTING**

- Place the vehicle on level ground.
- Loosen or tighten both chain adjusters ① equally until the chain has 25 – 35 mm (1.0 – 1.4 in) of slack at the middle of the chain between the engine and rear sprockets as shown.

**DATA** Drive chain slack:  
 Standard: 25 – 35 mm (1.0 – 1.4 in)

- After adjusting the drive chain, tighten the bolts ② to the specified torque.

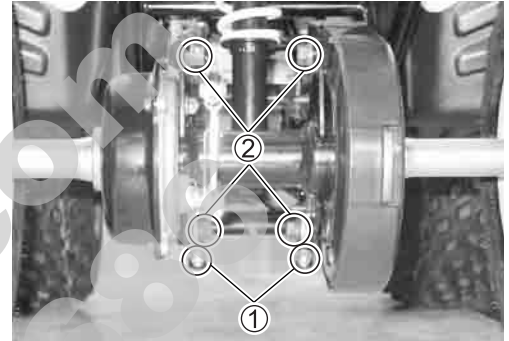

**U** Rear axle housing bolt: 50 N-m (5.0 kgf-m, 36.0 lb-ft)

- Recheck the drive chain slack.

**NOTE:**

After drive chain adjustment, adjust the rear brake.

\* Rear brake adjustment ..... ➔ 2-17

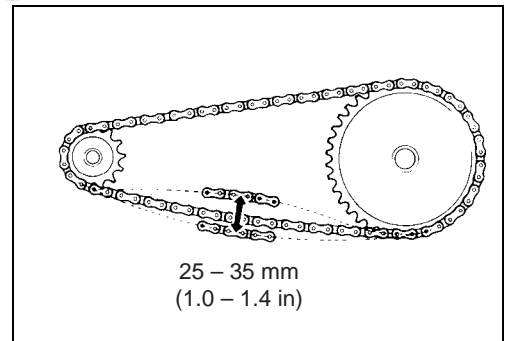

**CLEANING AND LUBRICATING**

- Remove the right rear tire. (☞ 5-8)
- Remove the chain case cover. (☞ 5-30)
- Clean the drive chain with kerosine. If the drive chain tends to rust quickly, the intervals must be shortened.



- After cleaning and drying the chain, oil it with a heavy-weight engine oil.

**CAUTION**

The drive chain joint clip should be attached in the way that the slit end will face opposite to the direction of travel.

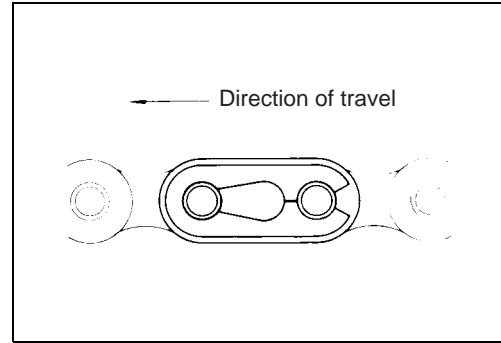

PartShark.com  
877-999-5686

## BRAKES

Inspect initially at 1 month and every 3 months thereafter.

### FRONT BRAKE LEVER PLAY

- Adjust the right and left cable end length (A) to become equal by adjusting nuts (1).
- Turn the adjusters (2) so that the brake lever play (B) is within specification after loosening the locknut.

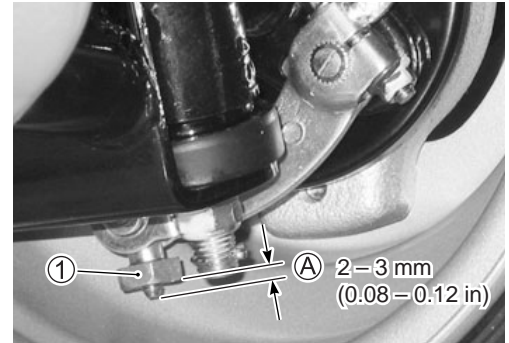

**DATA** Front brake lever play (B): 4 – 6 mm (0.16 – 0.24 in)

#### NOTE:

The difference between W1 and W2 should be 1 mm or less.

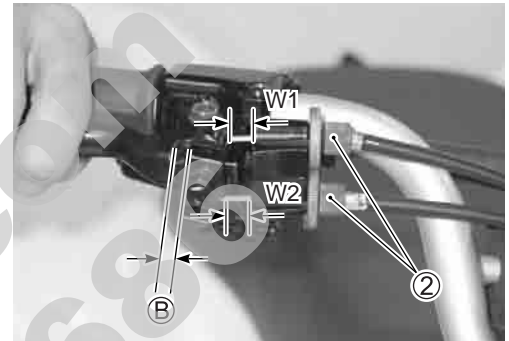

### REAR BRAKE LEVER PLAY

- Adjust the threaded portion length (C) of brake cable to 3 – 5 mm (0.12 – 0.20 in) by adjusting nut (1).
- Turn the adjuster (2) so that the free travel (D) is within specification after loosening the locknut.

**DATA** Rear brake lever play (D): 4 – 6 mm (0.16 – 0.24 in)

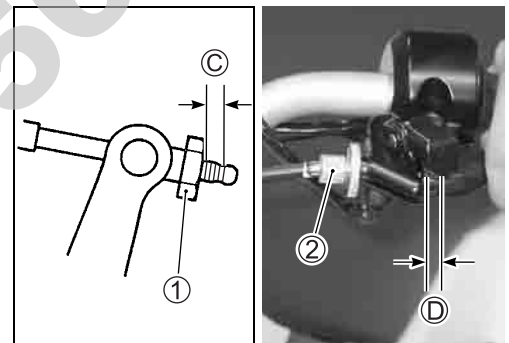

### FRONT AND REAR BRAKE SHOE WEAR

This vehicle is equipped with brake wear limit indicators for the front and rear brake. Check brake lining wear as follows:

- Make sure the brake lever play is properly adjusted.
- While fully applying the brake, check to see that the extension line of the index mark (1) is within the range (2).
- If the index mark goes beyond the range, the brake shoe assembly should be replaced with a new set of shoes.

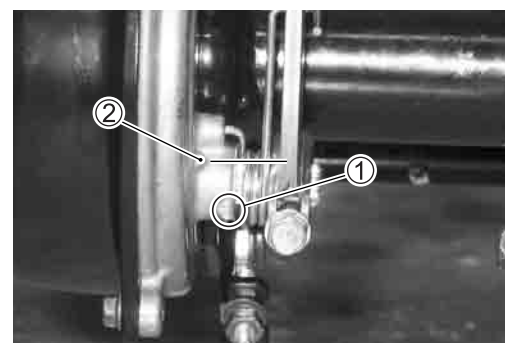
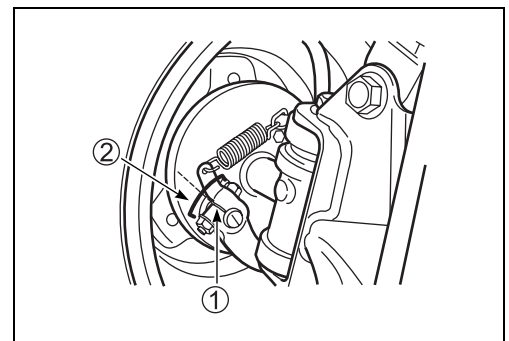



## TIRES

Inspect every month.

### TIRE TREAD CONDITION

Operating the vehicle with excessively worn tires will decrease riding stability and consequently invite a dangerous situation. It is highly recommended to replace a tire when the remaining depth of the tire tread reaches the following specification.

 **09900-20805: Tire depth gauge**

 **Service Limit:**

Tire tread depth: Front 4.0 mm (0.16 in)

Rear 4.0 mm (0.16 in)

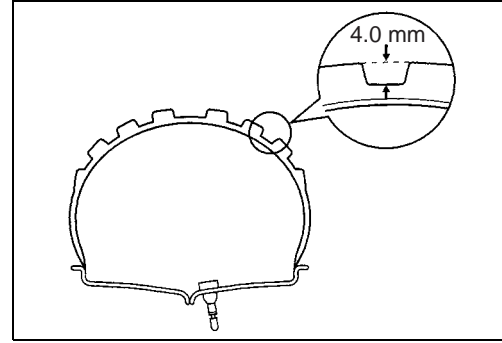

### TIRE PRESSURE

If the tire pressure is too high or too low, steering will be adversely affected and tire wear will increase. Therefore, maintain the correct tire pressure for good roadability and a longer tire life. Cold inflation tire pressure is as follows.

 **Cold inflation tire pressure:**

Front: 20 kPa (0.20 kgf/cm<sup>2</sup>, 2.9 psi)

Rear : 20 kPa (0.20 kgf/cm<sup>2</sup>, 2.9 psi)

VEHICLE LOAD CAPACITY LIMIT: 38 kg (84 lbs)

### CAUTION

To minimize the possibility of tire damage from over-inflation, we strongly recommended that a manual type air pump be used rather than a high pressure air compressor as found in service stations. When filling air into the tires, never exceed 70 kPa (0.7 kgf/cm<sup>2</sup>, 10 psi).

### CAUTION

The standard tire fitted on this vehicle is an AT16x8-7☆ for the front and rear. The use of tires other than those specified may cause instability. It is highly recommended to use the specified tires.

## STEERING

**Inspect initially at 1 month and every 3 months thereafter.**

Steering system should be adjusted properly for smooth manipulation of the handlebar and safe running.

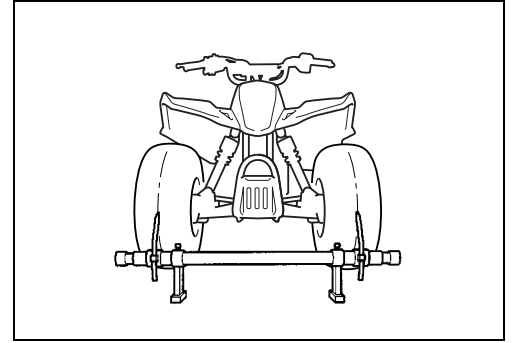

### TOE-IN

- Place the vehicle on level ground.
- Make sure the tire pressure for both tire is the same and set to the proper specification.
- Set the front wheels in the straight position.
- Place a load of 30 kg (66 lbs) on the seat.
- Measure the distance **A** and **B** of the front wheels, with a toe-in gauge as shown and calculate the difference between **A** and **B**.

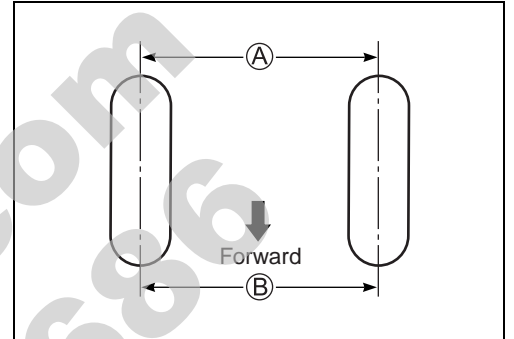

#### **DATA** Toe-in:

**Standard:  $1.5 \pm 3$  mm ( $0.06 \pm 0.12$  in)**

- If the toe-in is out of specification, bring it into the specified range. (☞ 5-28)

## SUSPENSIONS

**Inspect every 6 months.**

- Support the vehicle with a jack and wooden blocks.
- Remove the front and rear wheels. (☞ 5-8)
- Inspect the suspension arm, swingarm and bushing for scratches, wear, or defect. If any defects are found, replace them with new ones. (☞ 5-19 and 5-40)
- Inspect the front and rear shock absorbers for oil leakage or defects. If any defects are found, replace them with new ones. (☞ 5-19 and 5-40)

## CHASSIS NUTS AND BOLTS

**Tighten initially at 1 month and every 3 months thereafter.**

Check that all chassis nuts and bolts are tightened to their specified torque. (Refer to page 2-21 for the locations of the following nuts and bolts.)

Item	N·m	kgf·m	lb·ft
① Front suspension arm bolt	50	5.0	36.0
② Knuckle arm nut	50	5.0	36.0
③ Tie-rod end nut	29	2.9	21.0
④ Tie-rod locknut	29	2.9	21.0
⑤ Steering shaft lower nut	29	2.9	21.0
⑥ Steering shaft holder bolt	23	2.3	16.5
⑦ Handlebar clamp bolt	26	2.6	19.0
⑧ Front shock absorber bolt	(upper) 29	2.9	21.0
	(lower) 29	2.9	21.0
⑨ Front hub nut	65	6.5	47.0
⑩ Wheel set nut (front and rear)	28	2.8	20.0
⑪ Front brake cable equalizer bolt	6.5	0.65	4.5
⑫ Front brake cam lever nut	3.3	0.33	2.5
⑬ Swingarm pivot nut	102	10.2	74.0
⑭ Rear shock absorber bolt	29	2.9	21.0
⑮ Rear shock absorber nut	29	2.9	21.0
⑯ Rear hub nut	75	7.5	54.0
⑰ Rear brake cam lever nut	7.7	0.77	5.5
⑱ Rear brake panel nut	28	2.8	20.0
⑲ Rear axle housing bolt	50	5.0	36.0
⑳ Rear sprocket bolt	23	2.3	16.5
㉑ Footrest bolt	26	2.6	19.0

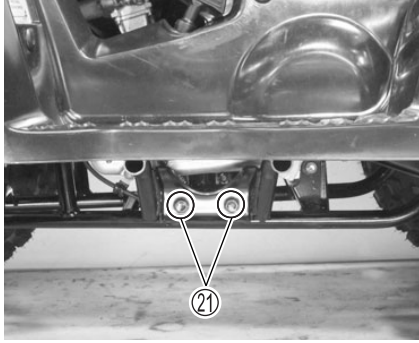
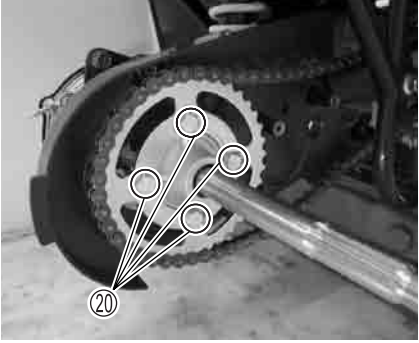
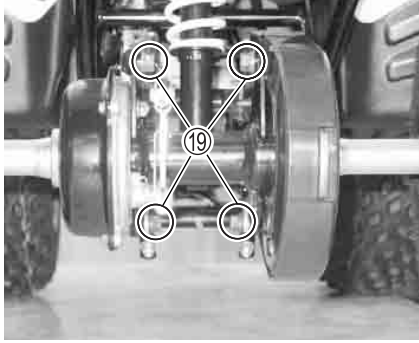
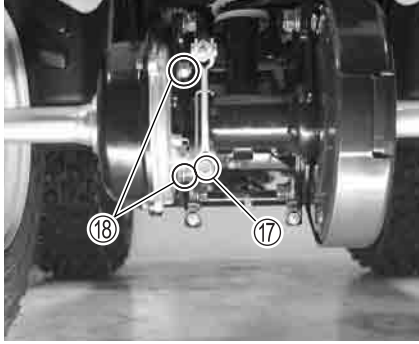
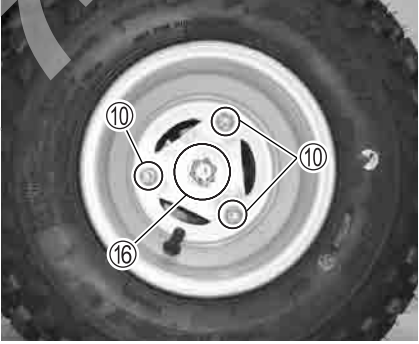
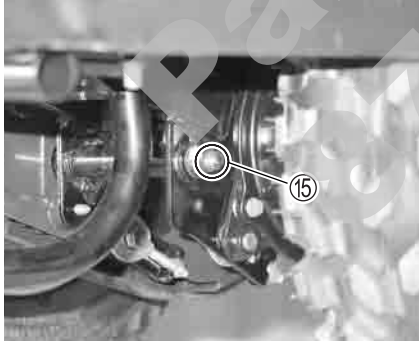
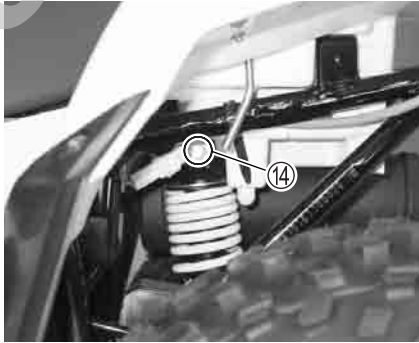
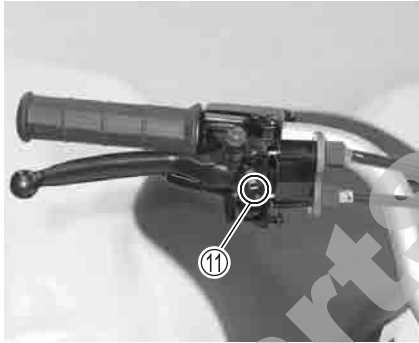
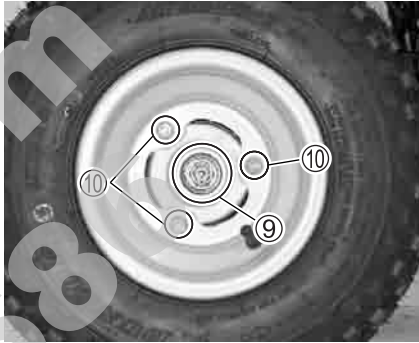
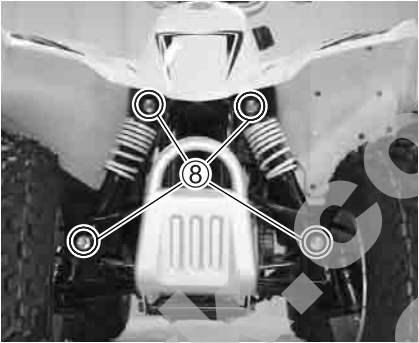
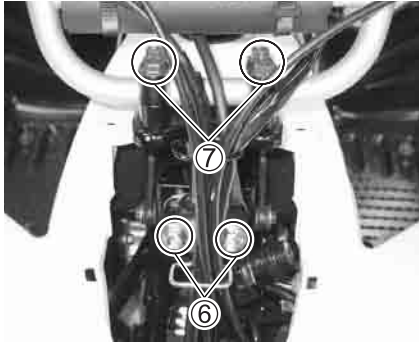
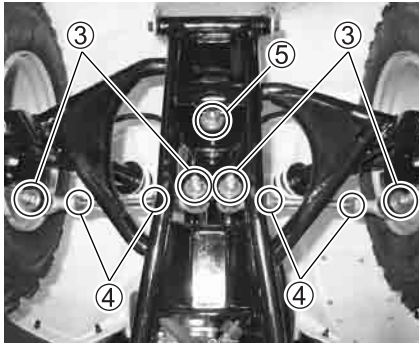
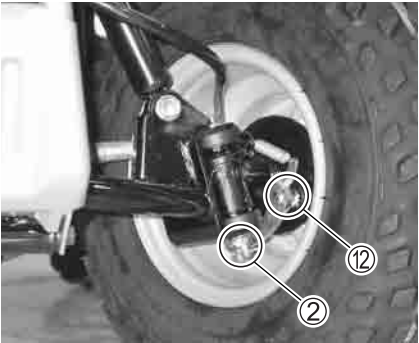
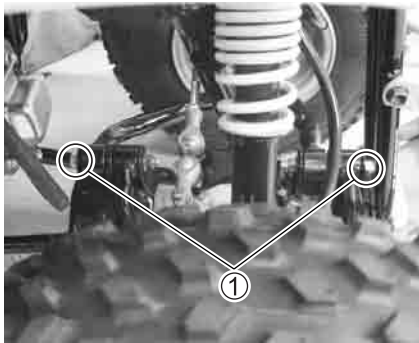

## GENERAL LUBRICATIONS

Lubricate every 3 months.

Proper lubrication is important for smooth operation and long life of each working part of the vehicle. Major lubrication points are indicated below.



- |                         |                      |                  |
|-------------------------|----------------------|------------------|
| ① Steering shaft holder | ② Brake lever holder | ③ Brake cable    |
| ④ Throttle cable        | ⑤ Drive chain        | ⑥ Throttle lever |

### NOTE:

\* Before lubricating each part, remove any rust and wipe off any grease, oil, dirt, or grime.

\* Lubricate exposed parts which are subject to rust, with a rust preventative spray, especially whenever the vehicle has been operated under wet or rainy conditions.

## COMPRESSION PRESSURE CHECK

The compression pressure reading of a cylinder is a good indicator of its internal condition. The decision to overhaul the cylinder is often based on the results of a compression test. Periodic maintenance records kept at your dealership should include compression readings for each maintenance service.

### **DATA** Compression pressure:

**Standard:** 1 100 – 1 200 kPa (11 – 12 kgf/cm<sup>2</sup>, 156 – 171 psi)

**Limit:** 800 kPa (8 kgf/cm<sup>2</sup>, 114 psi)

### Low compression pressure can indicate any of the following conditions:

- \* Excessively worn cylinder wall
- \* Worn piston or piston rings
- \* Piston rings stuck in grooves
- \* Poor valve seating
- \* Ruptured or otherwise defective cylinder head gasket

### NOTE:

*When the compression pressure goes below specification, check the engine for conditions listed above.*

## COMPRESSION TEST PROCEDURE

### NOTE:

- \* *Before testing the engine for compression pressure, make sure that the cylinder head bolts are tightened to the specified torque and the valves are properly adjusted.*
- \* *Have the engine warmed up before testing.*
- \* *Make sure that the battery is fully-charged.*

Remove the related parts and test the compression pressure in the following manner.

- Remove the spark plug. (☞ 2-7)
- Install the compression gauge and adaptor in the spark plug hole. Make sure that the connection is tight.
- Keep the throttle lever in the fully open position.
- Press the starter button and crank the engine for a few seconds. Record the maximum gauge reading as the cylinder compression.

**TOOL** 09915-64512: Compression gauge set  
09913-10750: Adaptor





## INITIAL ENGAGEMENT AND CLUTCH LOCK-UP INSPECTION

The LT-Z50 is equipped with a centrifugal type automatic clutch. To insure proper performance and longevity of the clutch assemblies it is essential that the clutches engage smoothly and gradually. Before checking the initial engagement and clutch lock-up two inspection checks must be performed to thoroughly check the operation of the drive train. Perform the following:

- Warm up the engine.

### INITIAL ENGAGEMENT INSPECTION

- Connect the multi-circuit tester onto the spark plug high-tension cord.
- Start the engine.
- Slowly open the throttle and note the engine speed (r/min) when the vehicle begins to move forward.

 **09900-25008: Multi-circuit tester set**

 **Engagement speed: 2 400 – 3 000 r/min**

If the engagement speed does not coincide with the standard range, inspect the following items for any abnormalities.

- \* Clutch shoe .....  3-39
- \* Clutch housing .....  3-40
- \* Movable drive and driven face .....  3-36, 38

## CLUTCH LOCK-UP INSPECTION

Perform this inspection to determine if the clutch is engaging fully and not slipping.



- Connect a multi-circuit tester onto the spark plug high-tension code.
- Start the engine.
- Apply the front and rear brakes as firmly as possible.
- Fully open the throttle for a brief period and note the maximum engine speed sustained during the test cycle.

**DATA** Lock-up speed: 3 300 – 4 300 r/min

### CAUTION

**Do not apply full power for more than 5 seconds or damage to the clutch or engine may occur.**

If the lock-up speed (r/min) does not coincide with the standard range, inspect the following items for any abnormalities.

- \* Clutch shoe .....  3-39
- \* Clutch housing.....  3-40
- \* Movable drive and driven face .....  3-36, 38

**NOTE:**

*Release the parking brake lock.*

PartShark.com  
877-999-5686



**PartShark.com**  
**877-999-5686**

# ENGINE

## CONTENTS

<b>ENGINE COMPONENTS REMOVABLE WITH ENGINE IN PLACE .....</b>	<b>3- 2</b>
<b>ENGINE CENTER .....</b>	<b>3- 2</b>
<b>ENGINE LEFT SIDE .....</b>	<b>3- 2</b>
<b>ENGINE RIGHT SIDE .....</b>	<b>3- 2</b>
<b>ENGINE REMOVAL AND INSTALLATION .....</b>	<b>3- 3</b>
<b>ENGINE REMOVAL .....</b>	<b>3- 3</b>
<b>ENGINE INSTALLATION .....</b>	<b>3- 6</b>
<b>POWER REDUCTION SPACER .....</b>	<b>3- 8</b>
<b>ENGINE DISASSEMBLY .....</b>	<b>3- 9</b>
<b>ENGINE COMPONENTS INSPECTION AND SERVICING .....</b>	<b>3-15</b>
<b>CYLINDER HEAD .....</b>	<b>3-15</b>
<b>ROCKER ARM PUSH ROD .....</b>	<b>3-20</b>
<b>CAMSHAFT ASSEMBLY .....</b>	<b>3-21</b>
<b>UPPER CRANKCASE/CYLINDER .....</b>	<b>3-21</b>
<b>PISTON AND PISTON RING .....</b>	<b>3-22</b>
<b>CONROD AND CRANKSHAFT .....</b>	<b>3-24</b>
<b>CAM ROCKER ARM .....</b>	<b>3-27</b>
<b>FINAL REDUCTION GEAR BOX AND CVT CASE .....</b>	<b>3-28</b>
<b>CVT CASE COVER .....</b>	<b>3-33</b>
<b>GENERATOR CASE .....</b>	<b>3-33</b>
<b>STARTER PINION .....</b>	<b>3-34</b>
<b>MOVABLE AND FIXED DRIVE AND DRIVEN FACE .....</b>	<b>3-35</b>
<b>RECOIL STARTER .....</b>	<b>3-43</b>
<b>ENGINE REASSEMBLY .....</b>	<b>3-47</b>

## ENGINE COMPONENTS REMOVABLE WITH ENGINE IN PLACE

The parts listed below can be removed and installed without removing the engine from the frame. Refer to the page listed in each section for removal and installation instructions.

### ENGINE CENTER

PARTS	REMOVAL	INSTALLATION
Carburetor	3-3	3-7
Muffler	3-3	3-8
Spark plug	3-9	3-56

### ENGINE LEFT SIDE

PARTS	REMOVAL	INSTALLATION
Recoil starter	3-11	–
CVT case cover	3-11	3-53
Starter pinion	3-11	3-53
Starter cup	3-11	3-52
Fixed drive face	3-11	3-52
Clutch housing	3-12	3-52
Clutch shoe/movable driven face	3-12	3-51
Drive belt	3-12	3-51

### ENGINE RIGHT SIDE

PARTS	REMOVAL	INSTALLATION
Generator cover	3-9	3-55
Generator rotor	3-10	3-54
Generator coil	3-10	3-53
Pick-up coil	3-10	3-53
Starter motor	3-10	3-54

## ENGINE REMOVAL AND INSTALLATION

### ENGINE REMOVAL

Before taking the engine out of the frame, wash the engine using a steam cleaner. Engine removal is sequentially explained in the following steps.

- Drain engine oil. (☞ 2-9)
- Remove the frame center cover. (☞ 5-5)

### MUFFLER

- Remove the exhaust pipe nuts.



- Remove the muffler mounting bolt.
- Remove the muffler ①.



### FOOTREST

- Remove the left footrest ①.

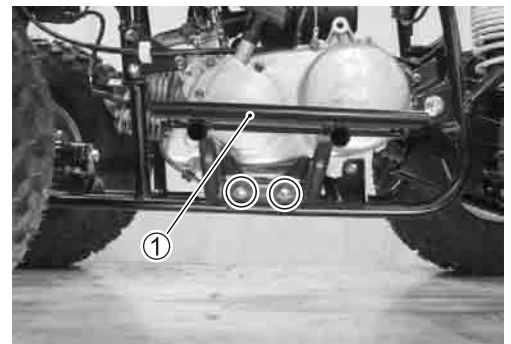

### CARBURETOR

- Turn the fuel valve ① to "ON" position.
- Remove the fuel hose ②.
- Loosen the intake pipe clamp bolt ③.
- Remove the drain hose ④ from the clamp.

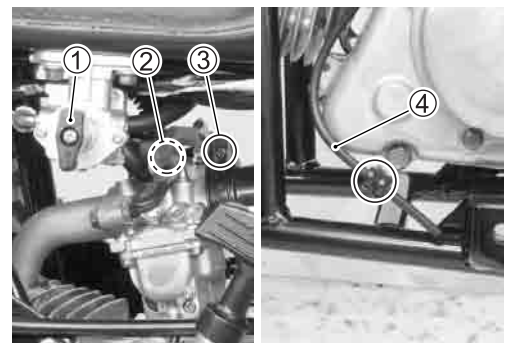

- Remove the vacuum hose ⑤.

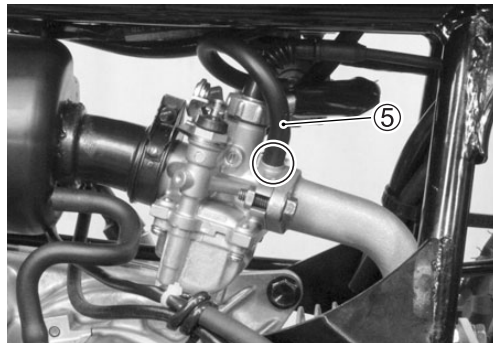

- Remove the carburetor assembly ⑥.

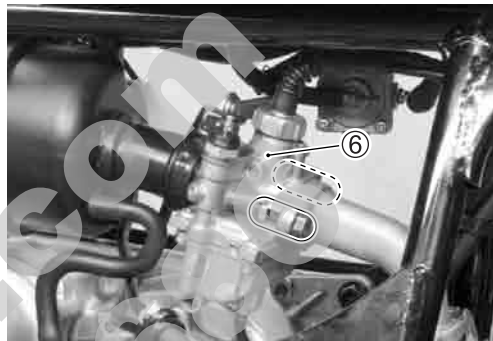

**DRIVE CHAIN**

- Remove the clip ①.
- Remove the drive chain ②.

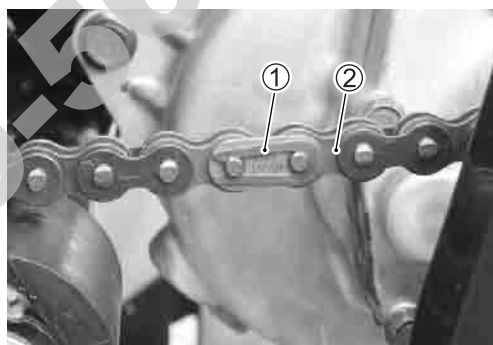

**ELECTRICAL PARTS AND HOSES**

- Disconnect the starter motor lead wire coupler ①.
- Disconnect the generator lead wire coupler ②.
- Remove the ground wire ③.
- Remove the breather hose ④.
- Remove the spark plug cap ⑤.

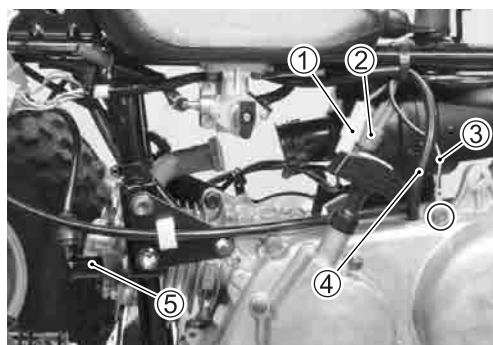

- Remove the rear brake cable guide ⑥.
- Remove the breather hose ⑦.

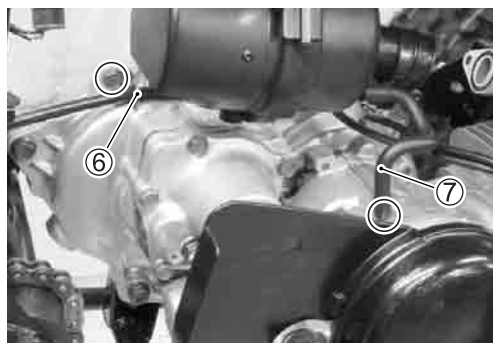

**ENGINE MOUNTING BRACKET AND BOLTS**

- Remove the engine mounting bracket ①.
- Remove the engine mounting bolts and nuts.
- Remove the engine from the left side.

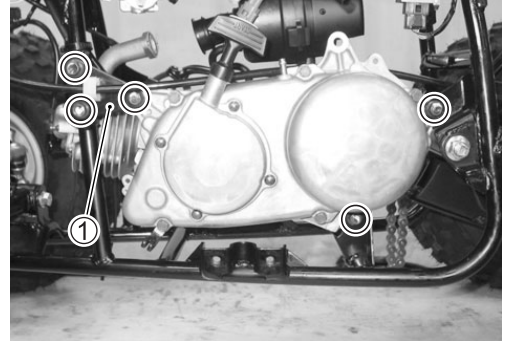

PartShark.com  
877-999-5688

## ENGINE INSTALLATION

Install the engine in the reverse order of engine removal. Pay attention to the following points:

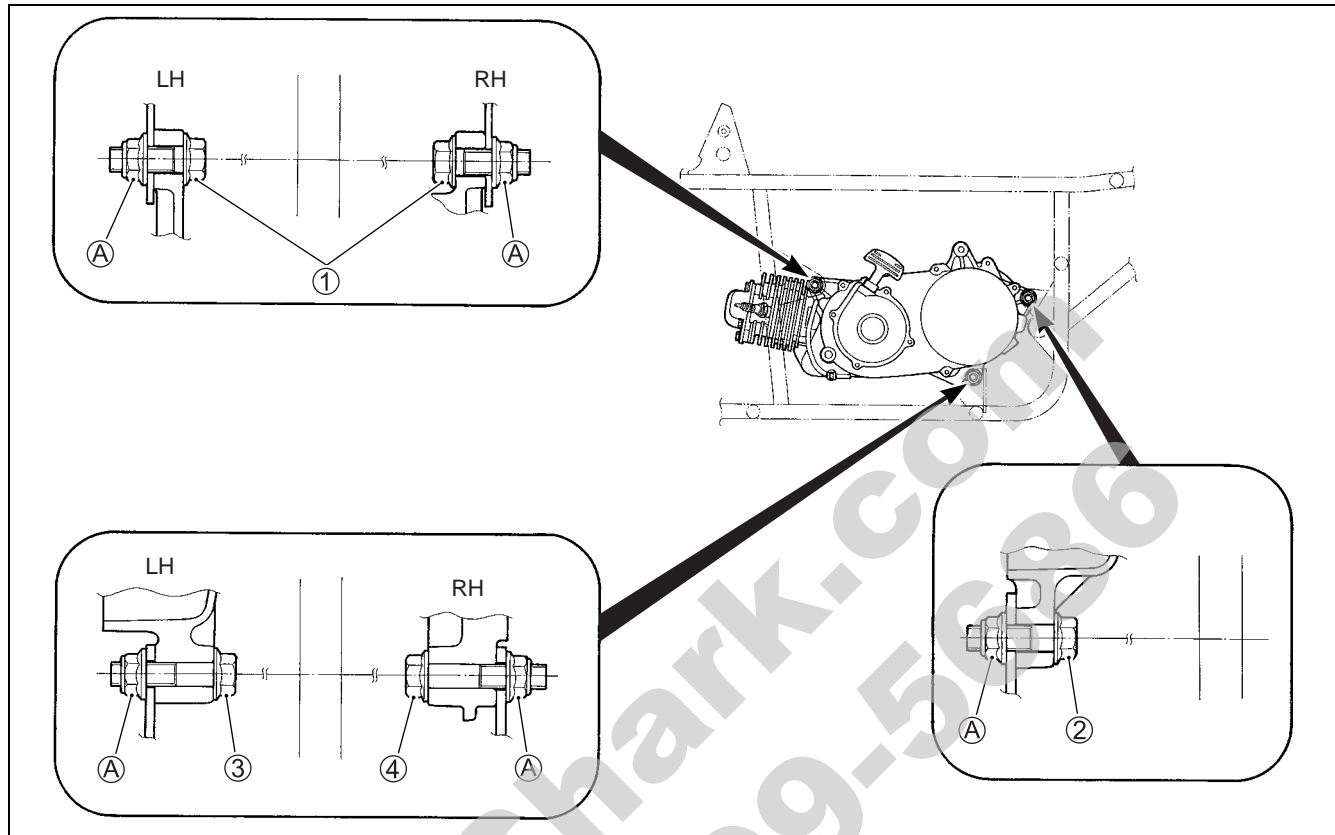

① Engine mounting bolt (25 mm)	④ Engine mounting bolt (40 mm)
② Engine mounting bolt (30 mm)	Ⓐ Engine mounting nut
③ Engine mounting bolt (35 mm)	



ITEM	N-m	kgf-m	lb-ft
Ⓐ	31	3.1	22.5

- Tighten the engine mounting nuts to the specified torque.

Engine mounting nut: 31 N-m (3.1 kgf-m, 22.5 lb-ft)

### CAUTION

The engine mounting nuts are self-locking. Once the nuts have been removed, they are no longer of use.

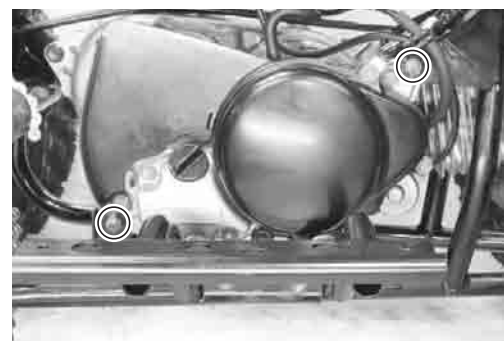
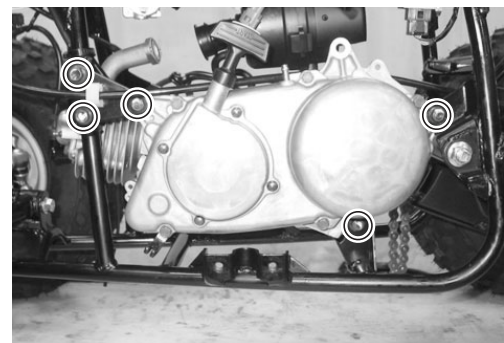





- Install the drive chain ①.
- Install the clip ②.

**CAUTION**

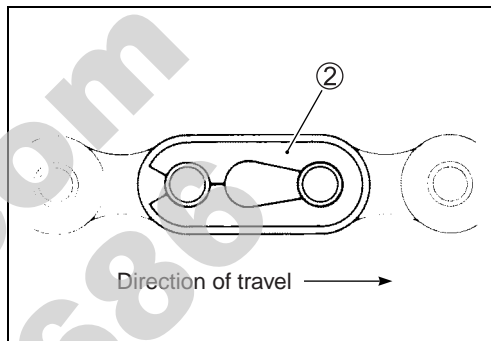
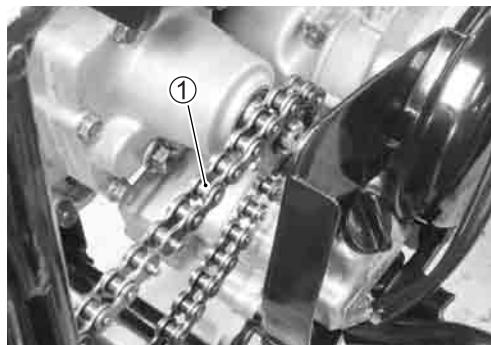
The drive chain joint clip should be attached in the way that the slit end will face opposite the direction of travel.



- Apply SUZUKI SUPER GREASE "A" to the O-ring.
-  99000-25010: SUZUKI SUPER GREASE "A" or equivalent

**CAUTION**

The removed O-ring must be replaced with a new one.



- Tighten the carburetor mounting bolts ③ to the specified torque.

 Carburetor mounting bolt: 6 N·m (0.6 kgf-m, 4.5 lb-ft)

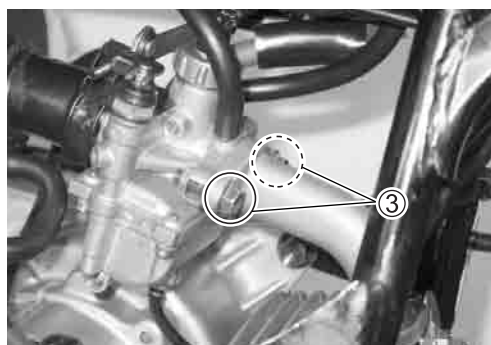

- Install the exhaust pipe gasket ④.

**CAUTION**

The removed gasket must be replaced with a new one.





- Tighten the exhaust pipe nuts to the specified torque.

 **Exhaust pipe nut: 10 N·m (1.0 kgf-m, 7.0 lb-ft)**



- Tighten the muffler mounting bolt to the specified torque.

 **Muffler mounting bolt: 23 N·m (2.3 kgf-m, 16.5 lb-ft)**



- After remounting the engine, inspect the lead wires and hoses routing. (☞ 7-14 to -18)
- Pour the specified engine oil. (☞ 2-9)
- Pour the specified final reduction gear box oil. (☞ 2-10)
- Perform the following adjustments:
  - \* Drive chain slack (☞ 2-15)
  - \* Engine idle speed (☞ 2-11)
  - \* Throttle cable play (☞ 2-10 to -11)

## POWER REDUCTION SPACER

The power reduction spacer has been installed inside of the movable drive.

### **WARNING**

**Do not remove the power reduction spacer until the rider develops sufficient skills to operate LT-Z50 safely at the maximum speed with the power reduction system in place.**

### REMOVAL

- Remove the left frame cover. (☞ 5-4)
- Remove the CVT case cover. (☞ 3-11)
- Remove the starter cup. (☞ 3-11)
- Remove the fixed drive face. (☞ 3-11)
- Remove the movable drive spacer ① and power reduction spacer ②.

### REMOUNTING

- Reinstall the movable drive in the reverse order of removal.

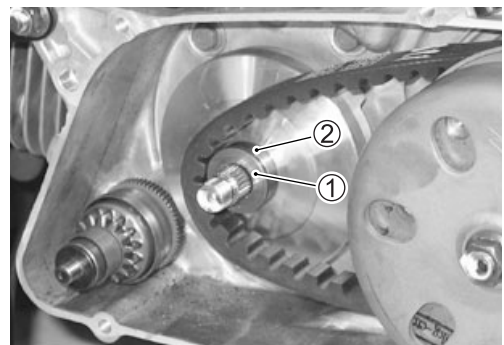

## ENGINE DISASSEMBLY

### SPARK PLUG

- Remove the spark plug with a spark plug wrench.

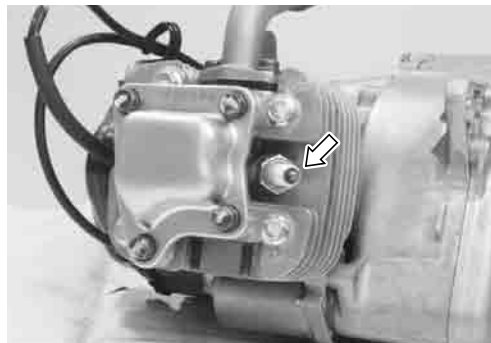

### CYLINDER HEAD COVER

- Remove the cylinder head cover ① and its gasket.

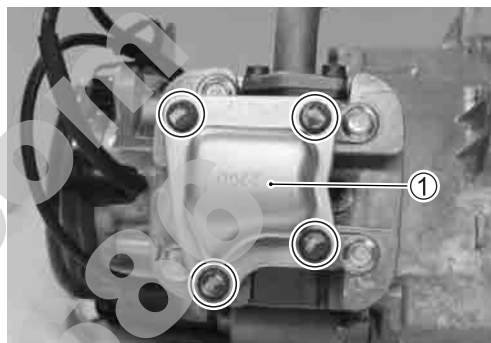

### GENERATOR COVER

- Remove the generator cover ①.

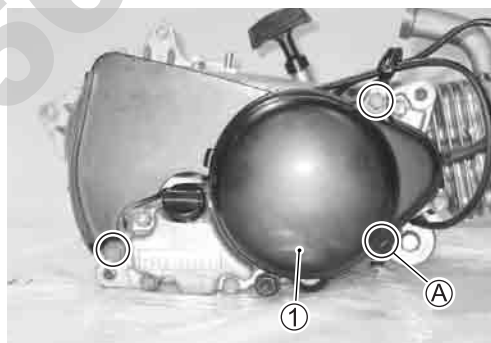

(A): Hooked part

### CYLINDER HEAD

- Turn the crankshaft counterclockwise to bring the line (A) on the generator rotor to the index mark (B) of the generator case.

#### NOTE:

When removing the cylinder head, piston must be at TDC on compression stroke.

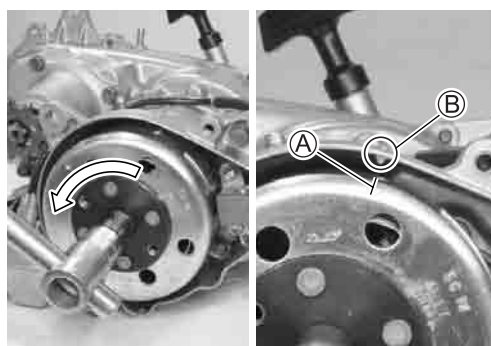

- Remove the cylinder head bolts.

#### NOTE:

Loosen the cylinder head bolts little by little and diagonally.

- Remove the cylinder head ①.

#### NOTE:

Rocker arm and valve disassembly. (☞ 3-15)

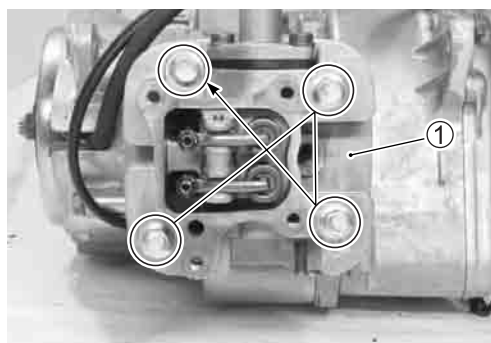

- Remove the push rods ②.
- Remove the gasket ③ and dowel pins ④.

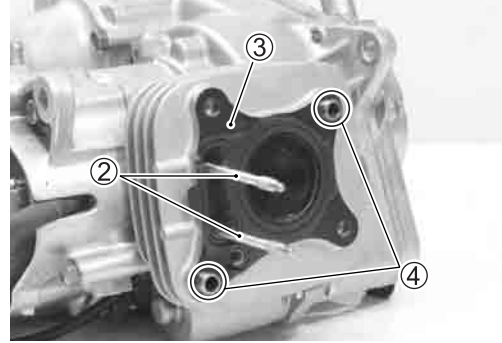

### STARTER MOTOR

- Remove the starter motor ①.

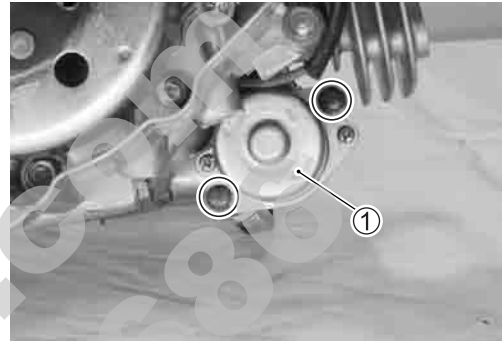

### GENERATOR

- Remove the generator rotor nut with the special tool.

 09930-40113: Rotor holder

#### CAUTION

Be careful not to damage the generator coil by the special tool.

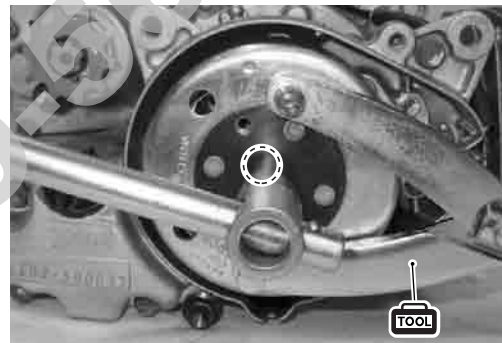

- Remove the generator rotor ① with the special tool and removed nut ②.

 09920-13120: Crankshaft separator

- Remove the generator rotor ① and nut ②.

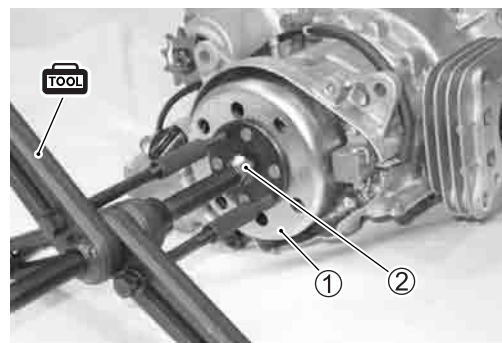

- Remove the key ③.
- Remove the generator coil ④ and pick-up coil ⑤.

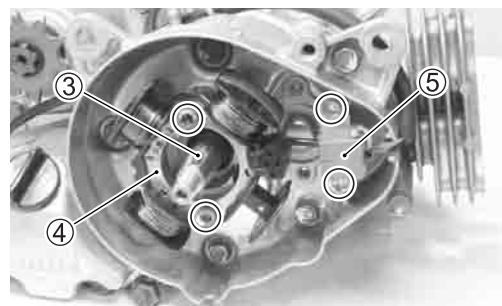

**RECOIL STARTER**

- Remove the recoil starter ①.

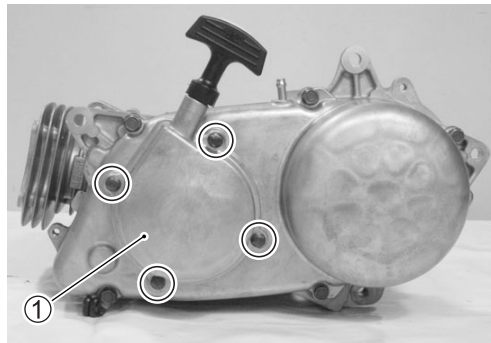
**MOVABLE DRIVE**

- Remove the CVT case cover ①.

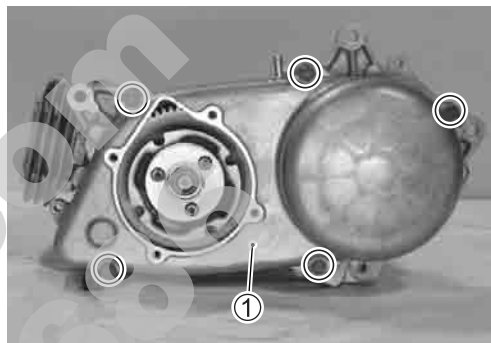

- Remove the dowel pins ② and gasket ③.
- Remove the starter pinion ④.

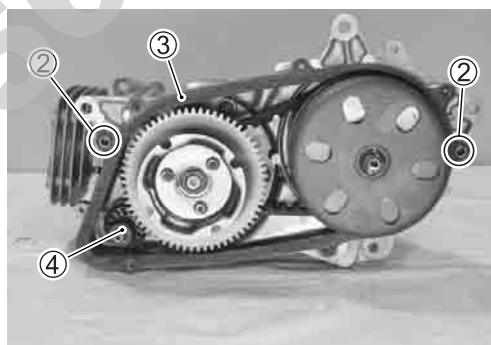

- Remove the fixed drive face nut ⑤ with the special tool.

**TOOL** 09930-40113: Rotor holder

- Remove the starter cup assembly.

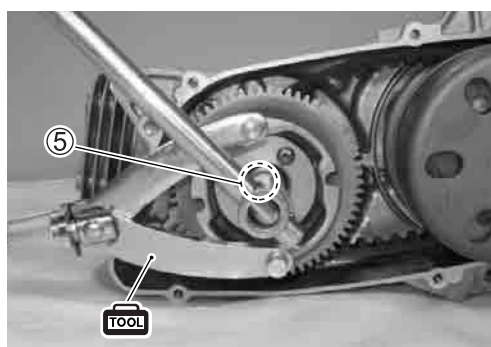

- Remove the fixed drive face ⑥.

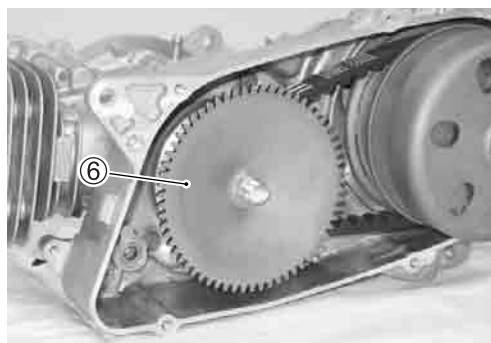



- Remove the movable drive spacer ⑦ together with the power reduction spacer ⑧ and movable drive face assembly ⑨.

NOTE:

Movable drive face disassembly. (☞ 3-36)

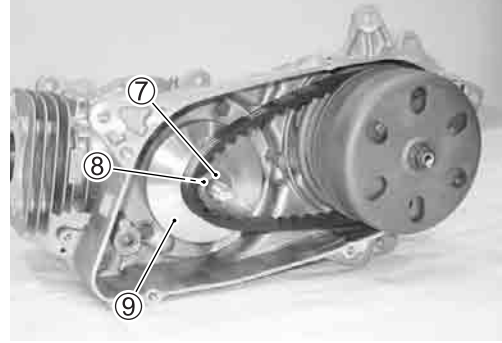

- Remove the washer ⑩.

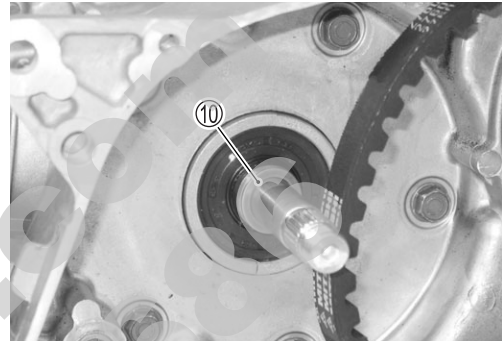

### MOVABLE DRIVEN

- Remove the clutch housing ① with the special tool.

 09930-40113: Rotor holder

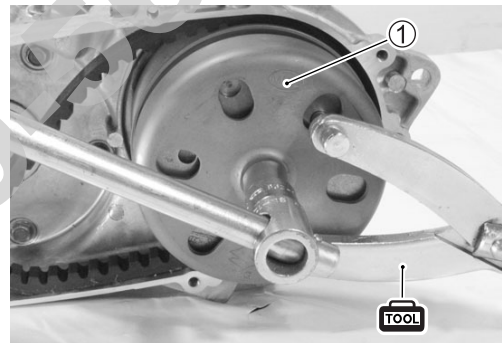

- Remove the clutch shoe/movable driven face assembly ② together with the drive belt ③.

NOTE:

Clutch shoe/movable driven face disassembly. (☞ 3-37)

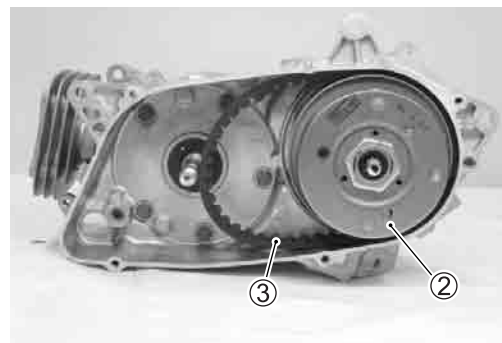

### CVT CASE

- Remove the CVT case ①.

NOTE:

Loosen the CVT case bolts little by little and diagonally.

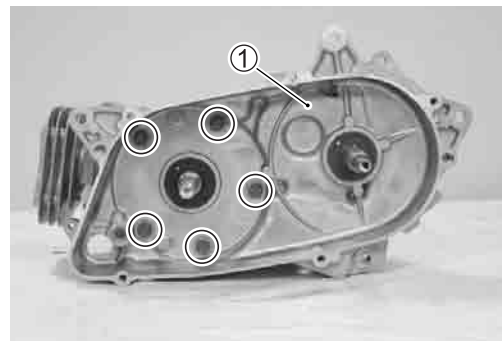

- Remove the dowel pins ② and gasket ③.

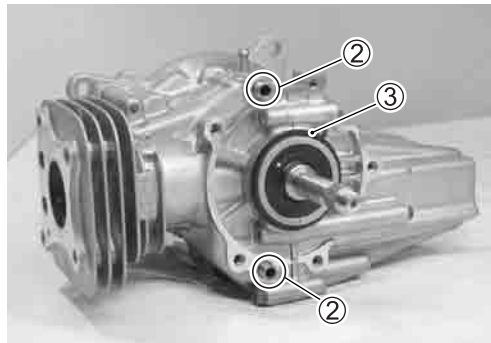

### GENERATOR CASE

- Remove the generator case ①.

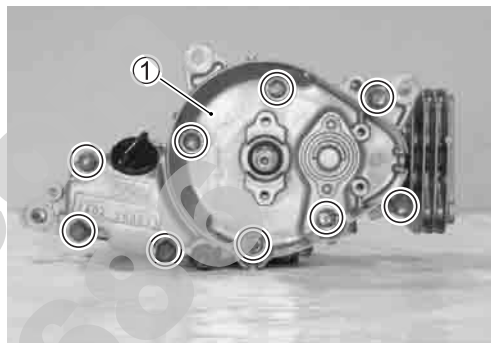

- Remove the dowel pins ② and gasket ③.

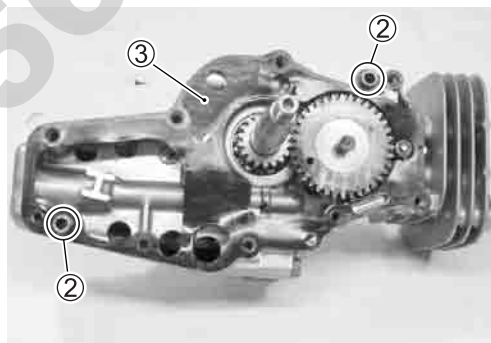

### CAM ROCKER ARM

- Remove the washer ① and camshaft assembly ②.

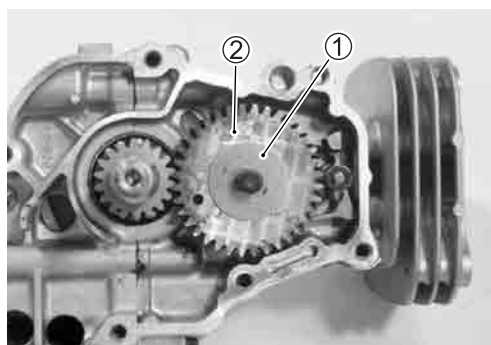

- Remove the washer ③, spring ④ and cam rocker arms ⑤.

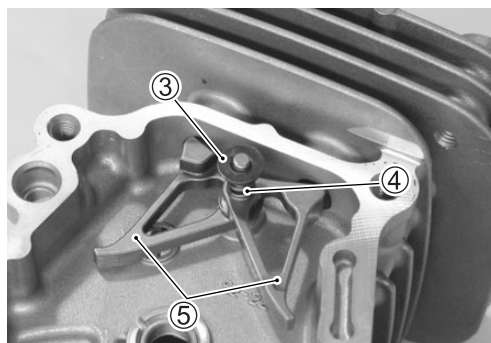

### UPPER CRANKCASE/CYLINDER AND LOWER CRANKCASE

- Remove the crankcase bolts.

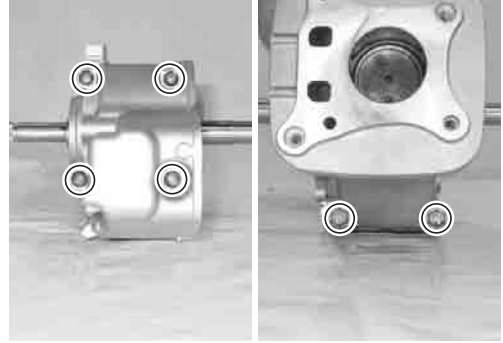

- Remove the dowel pins ①.

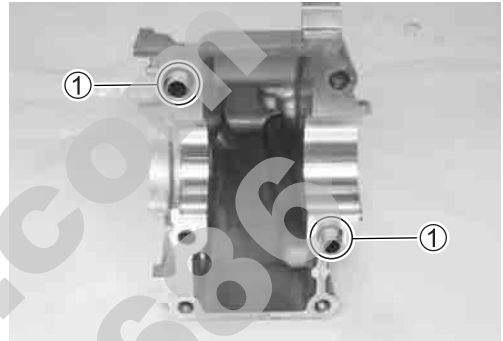

### CRANKSHAFT

- Remove the crankshaft ① together with piston.

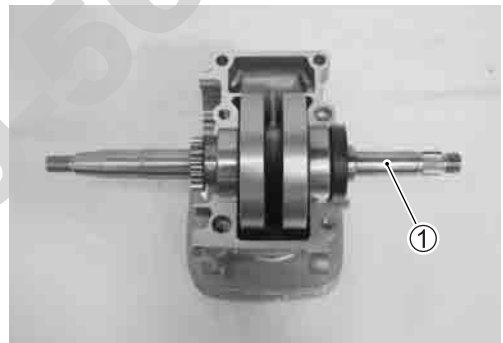

- Remove the crankshaft bearing retainer ②.

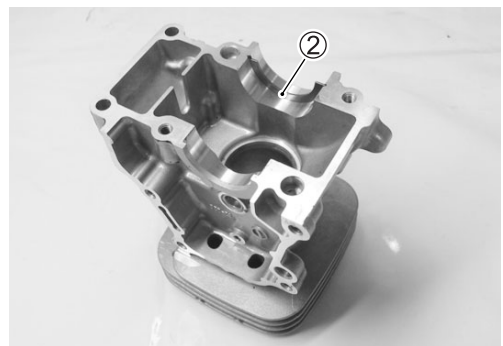

### PISTON

- Remove the piston pin circlip ①.
- Remove the piston pin ② and piston ③.

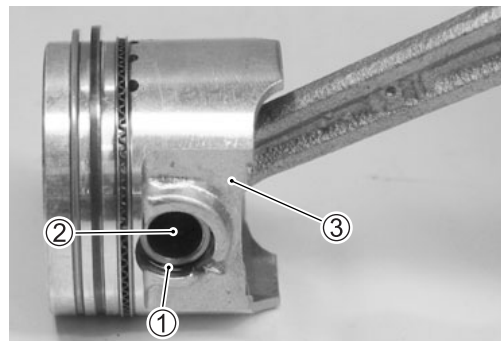

# ENGINE COMPONENTS INSPECTION AND SERVICING

## CYLINDER HEAD DISASSEMBLY

- Remove the intake pipe ① and insulator ②.

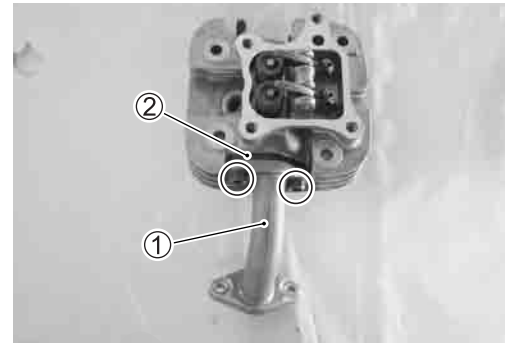

- Pull out the rocker arm shaft ③.
- Remove the intake rocker arm ④ and exhaust rocker arm ⑤.

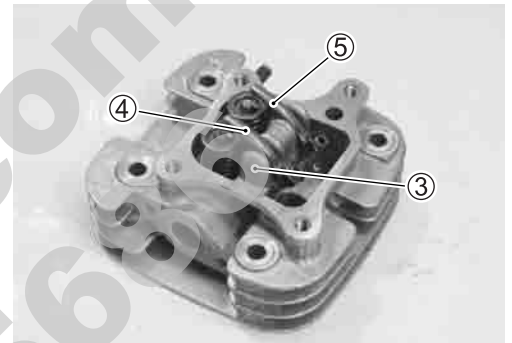

- Push the spring retainer ⑥ by the finger and move it side-ways.
- Remove the spring retainer ⑥ from the groove of the valve stem.
- Remove the valve spring ⑦.

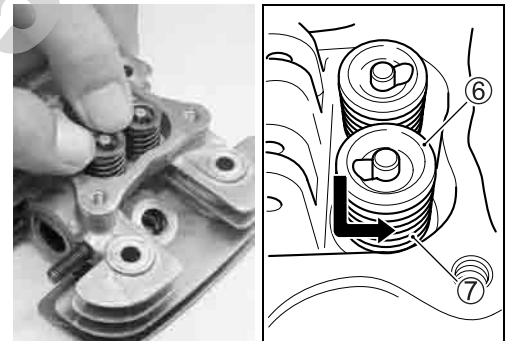

- Pull out the intake valve ⑧ and exhaust valve ⑨.

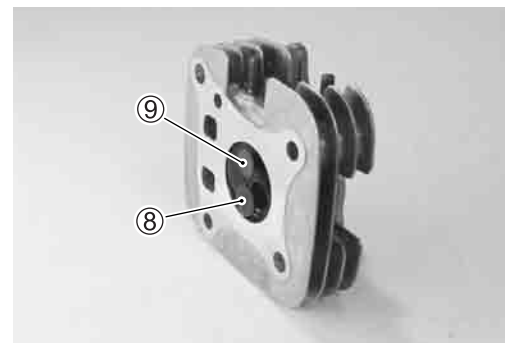



- Remove the intake valve stem seal ⑩ with an acute angle bar.

**CAUTION**

The removed valve stem seal must be replaced with a new one.

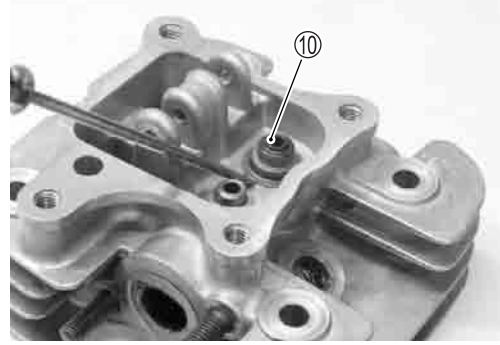
**ROCKER ARM SHAFT INSPECTION**

Inspect the rocker arm shaft for abnormal wear or damage. If it is worn or damaged, replace it with a new one.

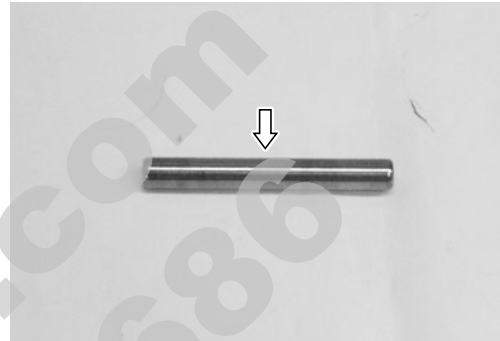
**ROCKER ARM INSPECTION**

Inspect the rocker arm for abnormal wear or damage. If they are worn or damaged, replace them with new ones.

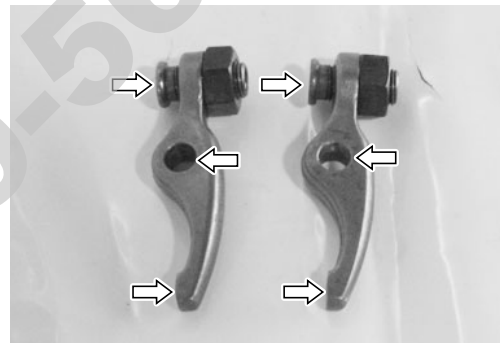
**CYLINDER HEAD DISTORTION**

- Decarbonize the combustion chamber.

Check the gasket surface of the cylinder head for distortion with a straightedge and thickness gauge, taking a clearance reading at several places indicated.

If the largest reading at any position of the straightedge exceeds the service limit, replace the cylinder head.

**DATA** Cylinder head distortion:  
Service Limit: 0.05 mm (0.002 in)

**TOOL** 09900-20803: Thickness gauge

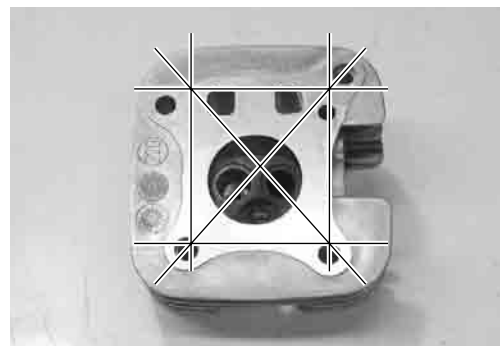

**VALVE FACE WEAR**

Visually inspect each valve for wear or damage of its seating face.

If anything unusual is found, replace the valve with a new one.

Measure the valve head thickness  $\text{T}$ .

If the thickness is less than the service limit, replace the valve with a new one.

**DATA** Valve head thickness (IN & EX):  
Service Limit: 0.5 mm (0.02 in)

**TOOL** 09900-20102: Vernier calipers

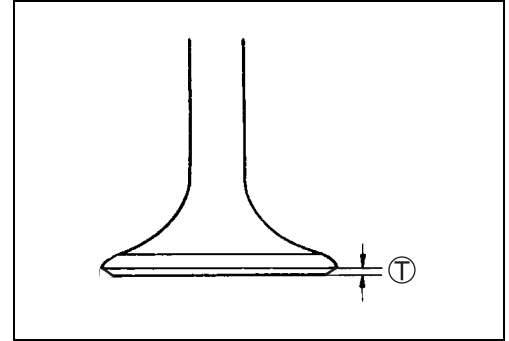
**VALVE STEM RUNOUT**

Support the valve on V-blocks and measure the valve stem runout.

If the valve stem runout exceeds the service limit, replace the valve.

**DATA** Valve stem runout (IN & EX):  
Service Limit: 0.05 mm (0.002 in)

**TOOL** 09900-20607: Dial gauge (1/100 mm)  
09900-20701: Magnetic stand  
09900-21304: V-block set (100 mm)

**VALVE HEAD RADIAL RUNOUT**

Place the dial gauge at right angles to the valve head face and measure the valve head radial runout.

If the valve head radial runout exceeds the service limit, replace the valve.

**DATA** Valve head radial runout (IN & EX):  
Service Limit: 0.03 mm (0.001 in)

**TOOL** 09900-20607: Dial gauge (1/100 mm)  
09900-20701: Magnetic stand  
09900-21304: V-block set (100 mm)

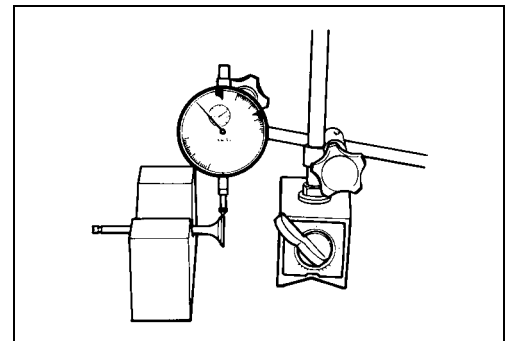
**VALVE STEM DEFLECTION**

Lift the valve head 10 mm (0.39 in) from the valve seat and measure the deflection in X and Y directions as shown.

If the deflection exceeds the service limit, measure the valve stem outside diameter.

**DATA** Valve stem deflection (IN & EX):  
Service Limit: 0.35 mm (0.014 in)

**TOOL** 09900-20607: Dial gauge (1/100 mm)  
09900-20701: Magnetic stand

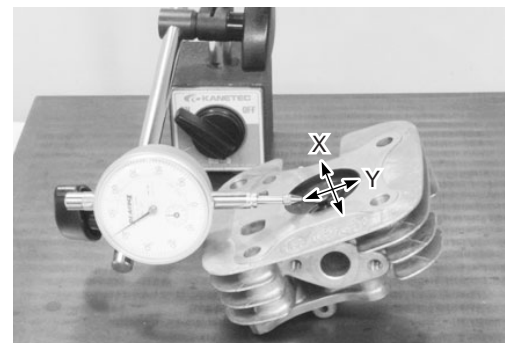

**VALVE STEM WEAR**

If the valve stem is worn down to the limit, as measured with a micrometer, replace the valve.

If the stem is within the limit, replace the cylinder head.

After replacing the valve, be sure to recheck the deflection.

**DATA** Valve stem O.D.:

**Standard (IN): 3.975 – 3.990 mm (0.1565 – 0.1571 in)**

**(EX): 3.960 – 3.975 mm (0.1559 – 0.1565 in)**

**TOOL** 09900-20205: Micrometer (0 – 25 mm)

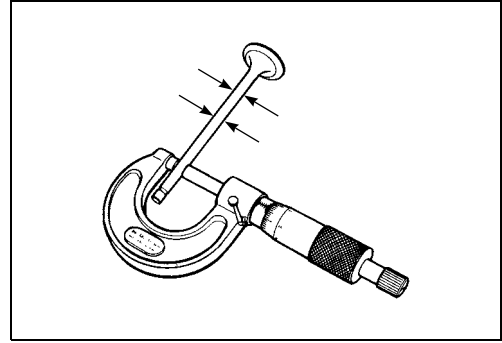
**VALVE SEAT**

- Install the valve and valve spring after cleaning.
- Pour a small quantity of gasoline into the intake or exhaust port.

Check that no gasoline leaks through the valve seat.

If leakage is found, replace the cylinder head.

**⚠ WARNING**

**Always use extreme caution when handling gasoline.**

**VALVE STEM END CONDITION**

Inspect the valve stem end face for abnormal wear or damage.

If abnormal wear or damage is found, resurface the valve stem end.

If the length  $\textcircled{A}$  is less than the service limit, the valve must be replaced.

**DATA** Valve stem end length (IN & EX):

**Service Limit: 3.0 mm (0.12 in)**

**TOOL** 09900-20102: Vernier calipers

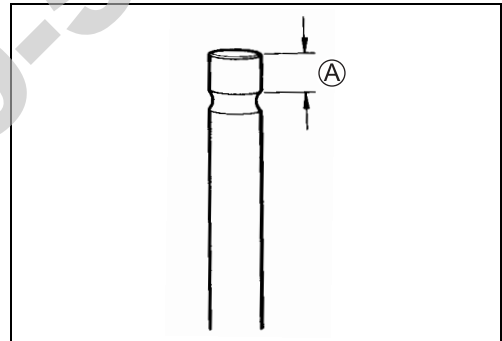

## VALVE SPRING

The force of the coil spring keeps the valve seat tight. Weakened spring results in reduced engine power output, and often account for the chattering noise coming from the valve mechanism.

- Check the valve springs for proper strength by measuring their free length and also by the force required to compress them.
- If the spring length is less than the service limit, or if the force required to compress the spring does not fall within the range specified, replace the valve spring.

**DATA** Valve spring free length (IN & EX):  
Service Limit: 22.8 mm (0.90 in)

**DATA** Valve spring tension (IN & EX):  
36.5 – 41.9 N (3.7 – 4.3 kgf, 8.2 – 9.5 lbs)  
at length 15.0 mm (0.59 in)

**TOOL** 09900-20102: Vernier calipers

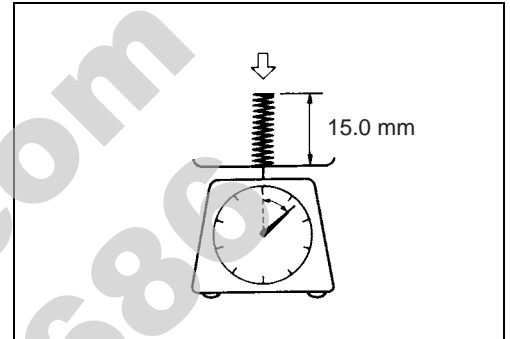
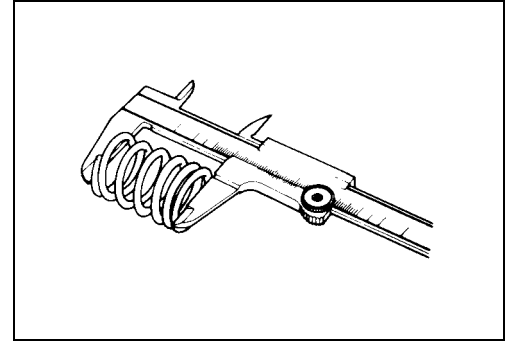

## REASSEMBLY

Reassemble the cylinder head in the reverse order of disassembly. Pay attention to the following points:

- Apply MOLYBDENUM OIL SOLUTION to the new stem seal.
- Press-fit the stem seal onto the intake valve guide.

### CAUTION

The removed valve stem seal must be replaced with a new one.

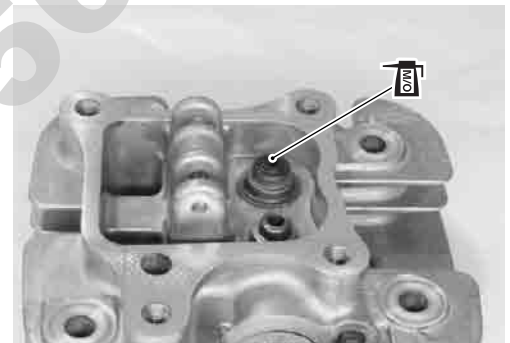

### **MOLYBDENUM OIL SOLUTION**

- Insert the valves, with their stems coated with MOLYBDENUM OIL SOLUTION all around and along the full stem length without any break.

### CAUTION

When inserting intake valve, take care not to damage the lip of the stem seal.

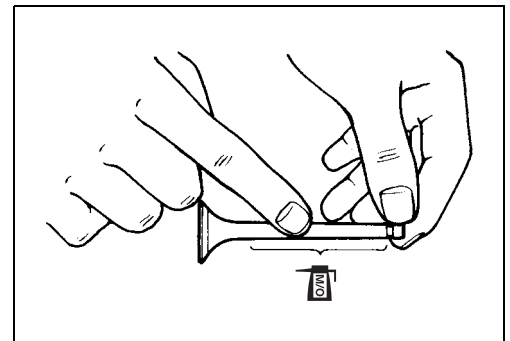

### **MOLYBDENUM OIL SOLUTION**

- Assemble the valve spring ① and spring retainer ②.
- Push the spring retainer by the finger with the valve prevented from falling.
- Incline the spring retainer ② and set it into the valve stem groove.

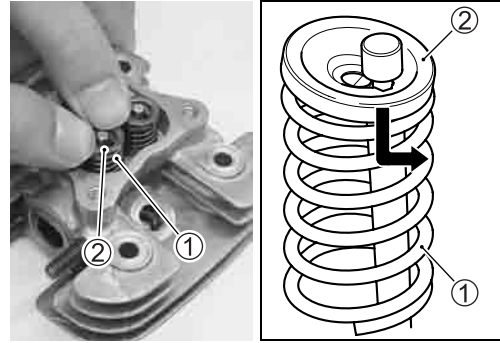

**CAUTION**

Make sure that the spring retainer fits snugly into the groove (A) on the valve stem end.

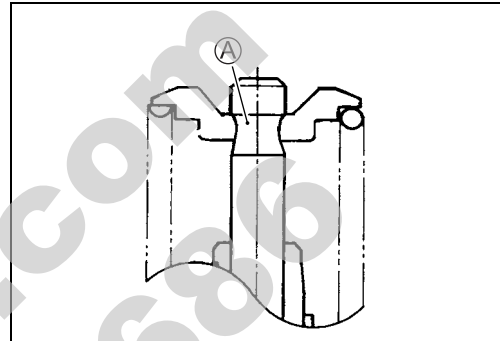

- Apply engine oil to the rocker arm shaft ③.
- Install the rocker arm shaft ③.



- Install the new O-rings ④ to the intake pipe ⑤ and insulator ⑥.

**CAUTION**

The removed O-rings must be replaced to prevent air from sucking through the joint.

- Tighten the intake pipe bolts to the specified torque.

 Intake pipe bolt: 6 N·m (0.6 kgf·m, 4.5 lb·ft)

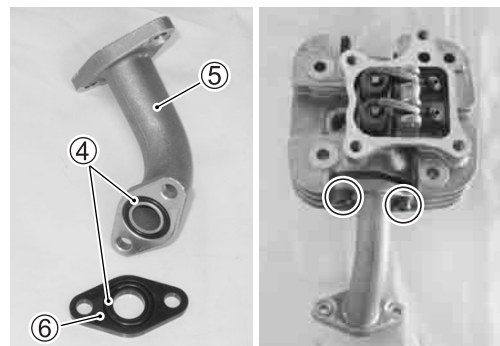

**ROCKER ARM PUSH ROD**

**INSPECTION**

Inspect the rocker arm push rods for abnormal wear, damage or bend.

If any abnormal condition is found, replace the push rod with a new one.



## CAMSHAFT ASSEMBLY

### INSPECTION

Check the camshaft for abnormal wear or damage.

Measure the cam height  $\ominus$  with a micrometer.

If the cam height  $\ominus$  is less than the service limit, replace the camshaft assembly with a new one.

**DATA** Cam height  $\ominus$  (IN & EX):  
Service Limit: 28.13 mm (1.1075 in)

### CAUTION

Do not attempt to disassemble the camshaft assembly.

**TOOL** 09900-20202: Micrometer (25 – 50 mm)

- Install the camshaft assembly as shown in the photograph, if disassemble it.

### NOTE:

- \* Align the shaft punch mark with the cam punch mark.
- \* Assemble the springs ① diagonally.

①: Spring

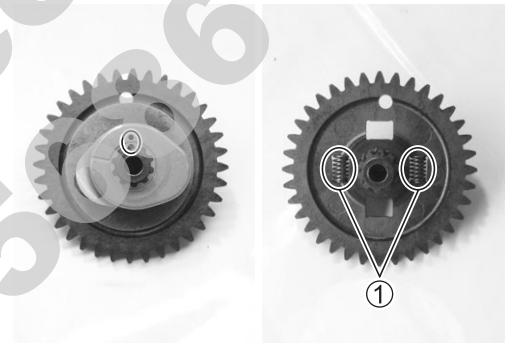
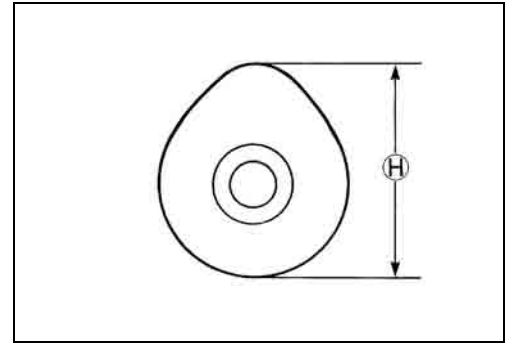

## UPPER CRANKCASE/CYLINDER BUSHING

Inspect the bushing ① for wear or damage.

If any defects are found, replace it with a new one.

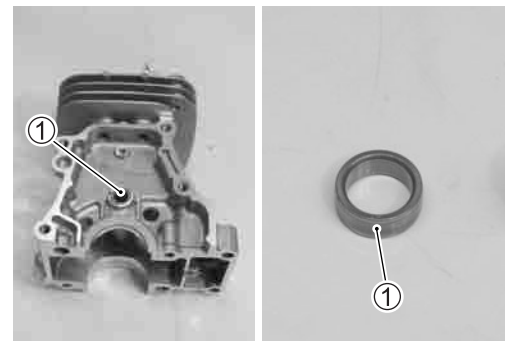

## CYLINDER DISTORTION

Check the gasket surface of the cylinder for distortion with a straightedge and thickness gauge, taking a clearance reading at several places as indicated.

If the largest reading at any position of the straightedge exceeds the service limit, replace the upper crankcase/cylinder.

**DATA** Cylinder distortion:  
Service Limit: 0.05 mm (0.002 in)

**TOOL** 09900-20803: Thickness gauge

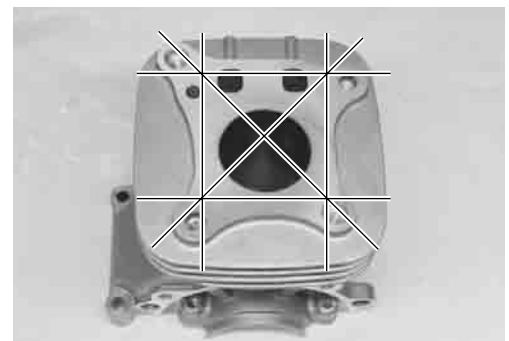



**CYLINDER BORE**

Inspect the cylinder wall for any scratches, nicks or other damage.

If anything unusual is found, replace the upper crankcase/cylinder.

Measure the cylinder bore diameter at six places.

**DATA** Cylinder bore:  
Standard: 36.005 – 36.015 mm (1.4175 – 1.4179 in)

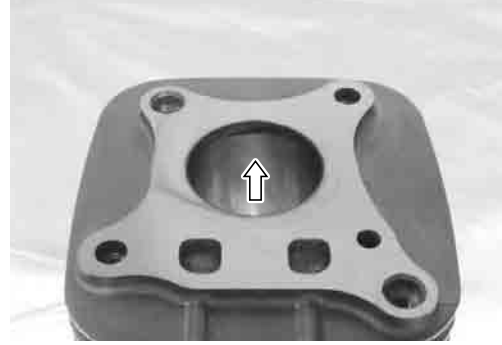
**PISTON AND PISTON RING****PISTON DIAMETER**

Measure the piston outside diameter at 5 mm (0.2 in) height from the skirt with a micrometer.

If the measurement is less than the service limit, replace the piston.

**DATA** Piston diameter:  
Service Limit: 35.885 mm (1.4128 in)

**TOOL** 09900-20202: Micrometer (25 – 50 mm)

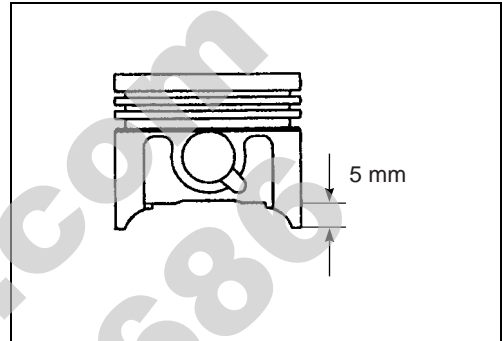
**PISTON-TO-CYLINDER CLEARANCE INSPECTION**

Subtract the piston diameter from the cylinder bore diameter. (↪ 3-21)

If the piston-to-cylinder clearance exceeds the service limit, replace the upper crankcase/cylinder or the piston, or both.

**DATA** Piston-to-cylinder clearance:  
Service Limit: 0.120 mm (0.0047 in)

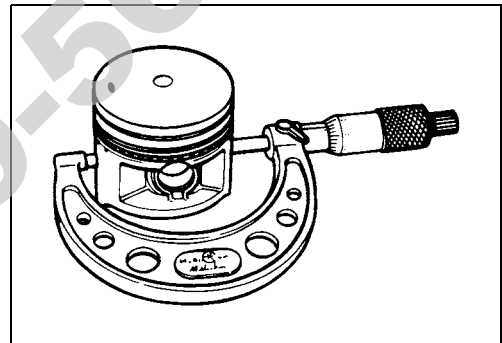
**PISTON RING TO GROOVE CLEARANCE**

Measure the side clearances of the 1st and 2nd piston rings with the thickness gauge.

If any of the clearances exceeds the limit, replace both the piston and piston rings.

**DATA** Piston ring to groove clearance:  
Service Limit (1st): 0.180 mm (0.0071 in)  
(2nd): 0.150 mm (0.0059 in)

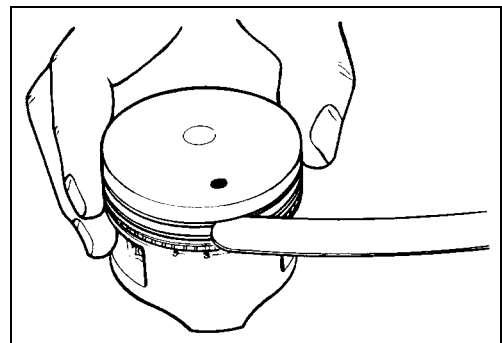

**DATA** Piston ring groove width:  
Standard (1st): 1.01 – 1.03 mm (0.0398 – 0.0405 in)  
(2nd): 1.21 – 1.23 mm (0.0476 – 0.0484 in)  
(Oil): 1.51 – 1.53 mm (0.0594 – 0.0602 in)

**DATA** Piston ring thickness:  
Standard (1st): 0.97 – 0.99 mm (0.0382 – 0.0390 in)  
(2nd): 1.17 – 1.19 mm (0.0461 – 0.0469 in)

**TOOL** 09900-20803: Thickness gauge  
09900-20205: Micrometer (0 – 25 mm)

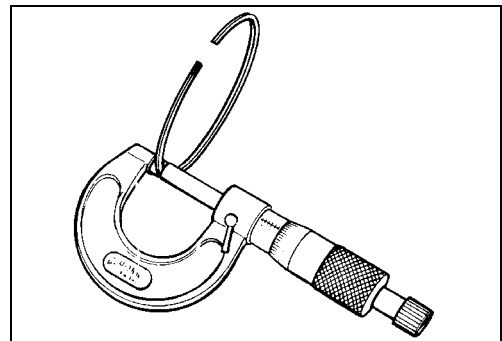

**PISTON RING FREE END GAP AND PISTON RING END GAP**

Measure the piston ring free end gap with a vernier calipers. Next, fit the piston ring squarely into the cylinder and measure the piston ring end gap with a thickness gauge.

If any of the measurements exceeds the service limit, replace the piston ring with a new one.

**DATA** Piston ring free end gap:

Service Limit (1st): 3.7 mm (0.15 in)  
(2nd): 3.7 mm (0.15 in)

**TOOL** 09900-20102: Vernier calipers**DATA** Piston ring end gap:

Service Limit (1st): 0.50 mm (0.020 in)  
(2nd): 0.50 mm (0.020 in)

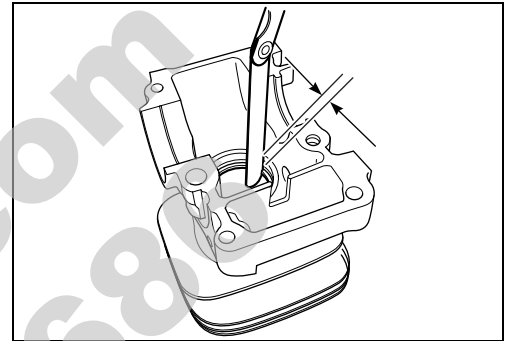
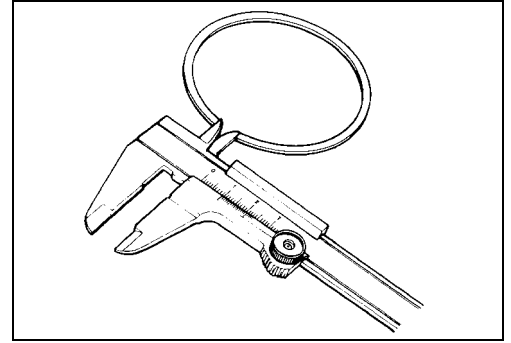
**TOOL** 09900-20803: Thickness gauge**PISTON PIN AND PIN BORE**

Measure the piston pin bore inside diameter with a small bore gauge.

If the measurement is more than the service limit, replace the piston.

**DATA** Piston pin bore I.D.:

Service Limit: 10.030 mm (0.3949 in)

**TOOL** 09900-20602: Dial gauge (1/1000 mm, 1 mm)

09900-22401: Small bore gauge (10 – 18 mm)

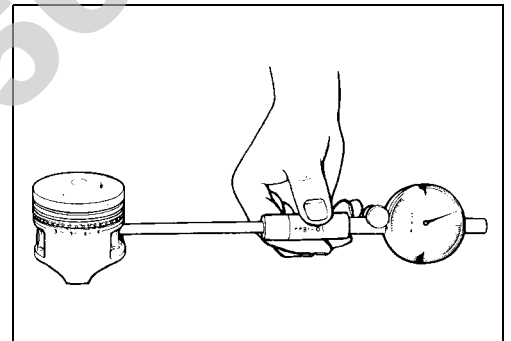

Measure the piston pin outside diameter at three positions with a micrometer.

If any of the measurements is less than the service limit, replace the piston pin.

**DATA** Piston pin O.D.:

Service Limit: 9.980 mm (0.3929 in)

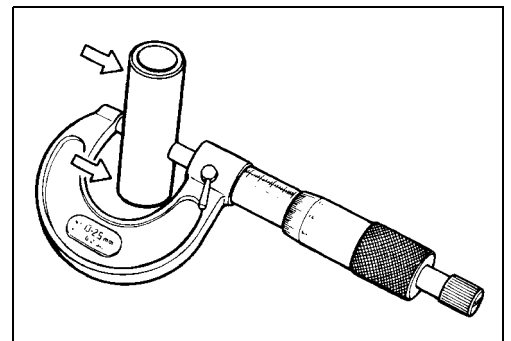
**TOOL** 09900-20205: Micrometer (0 – 25 mm)



## CONROD AND CRANKSHAFT

### CONROD SMALL END I.D.

Measure the conrod small end inside diameter with a caliper gauge.

If the conrod small end inside diameter exceeds the service limit, replace the conrod.

**DATA** Conrod small end I.D.:

**Service Limit: 10.040 mm (0.3952 in)**

**TOOL** 09900-20605: Dial calipers (10 – 34 mm)

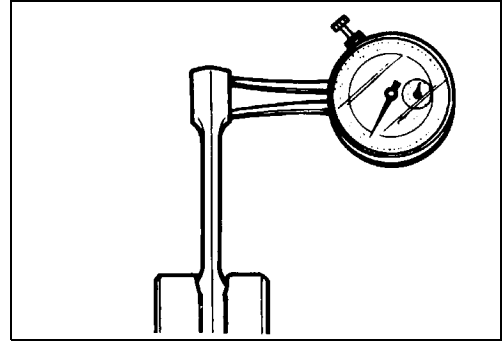

### CONROD DEFLECTION

Wear on the big end of the conrod can be estimated by checking the movement of the small end of the rod.

This method can also check the extent of wear on the conrod's big end.

**DATA** Conrod deflection:

**Service Limit: 3.0 mm (0.12 in)**

**TOOL** 09900-20607: Dial gauge (1/100 mm)

09900-20701: Magnetic stand

09900-21304: V-block set (100 mm)

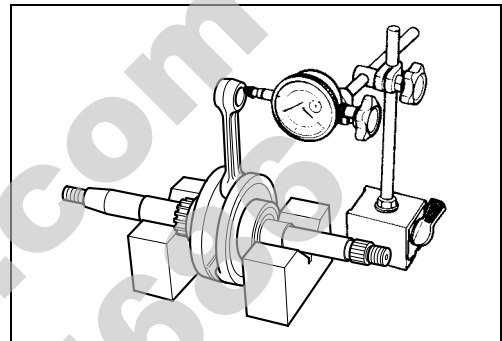

**CRANKSHAFT BEARING INSPECTION**

Inspect the outer race play and smooth rotation of the bearing by hand while it is on the crankshaft.

If any abnormality is found, replace the bearing with a new one.

**NOTE:**

*If there is no abnormal noise, the bearing removal is not necessary.*

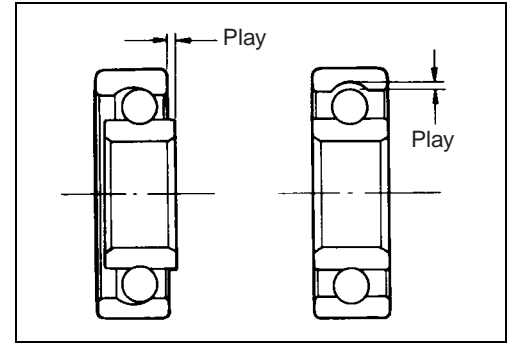
**CRANKSHAFT BEARING REMOVAL****CAUTION**

Remove the cam drive gear ① together with the right crankshaft bearing. The cam drive gear ① is the cam timing gear. Because extreme accuracy is required when press-fitting it, replacing the crankshaft assembly is recommended.

- Remove the crankshaft bearing and cam drive gear with the suitable tool as shown in the photograph.



PartShark.com  
877-999-5689

**CRANKSHAFT BEARING INSTALLATION**

- Press-fit the bearing with the bearing installer and suitable plate as shown in the illustration.

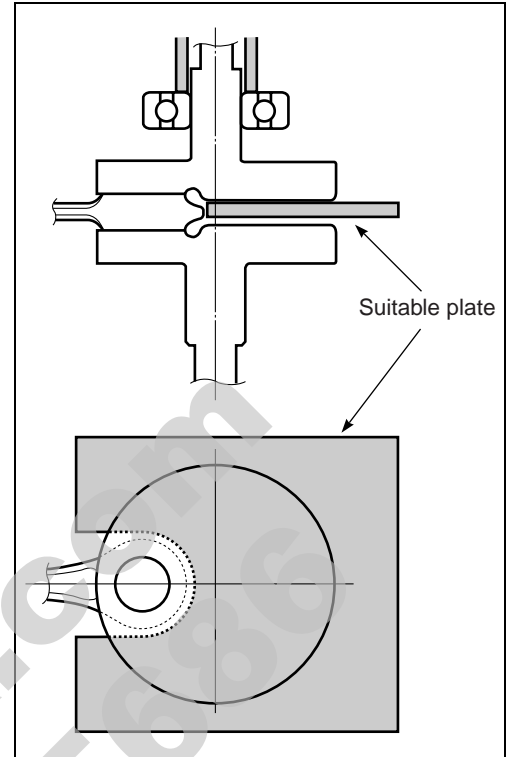

- Press-fit the cam drive gear ① with the suitable tool.

**DATA** Phase angle between the crank pin center (A) and the cam drive gear engraved line (B):  $0^\circ \pm 30'$

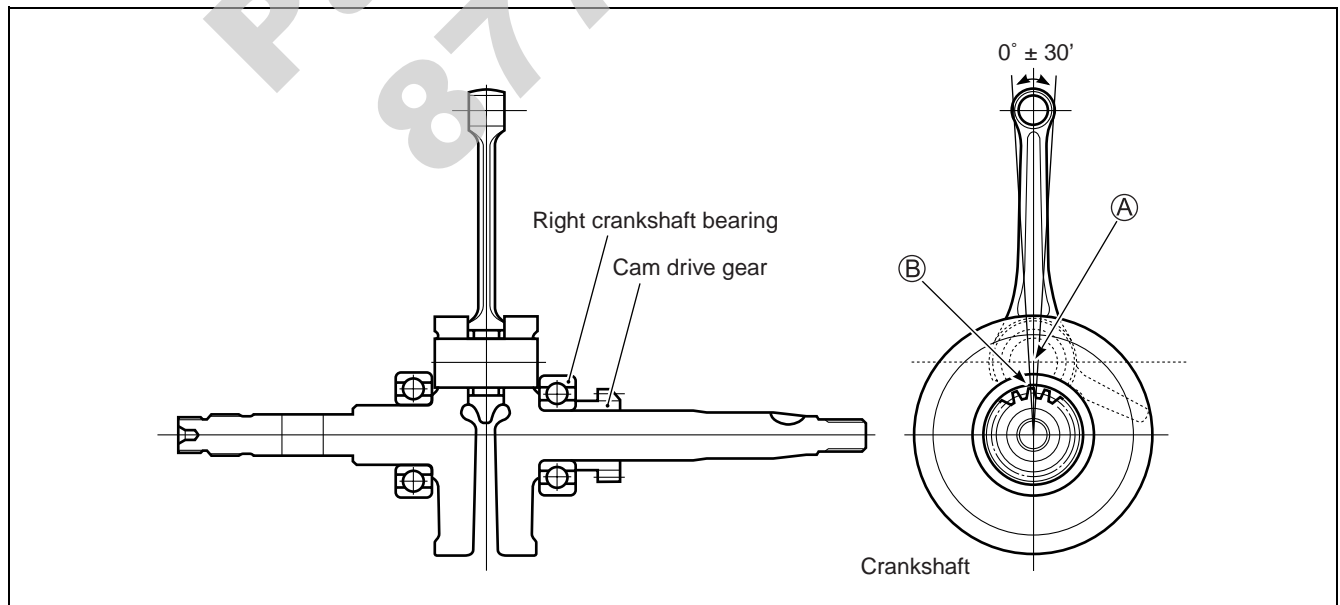
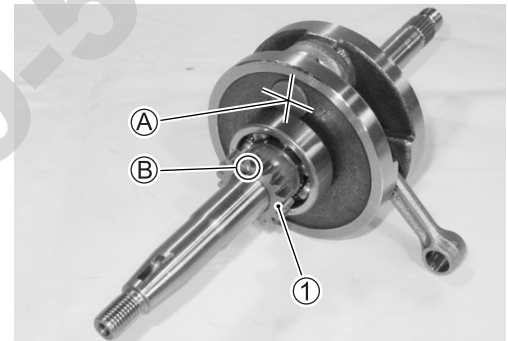

**CONROD BIG END SIDE CLEARANCE INSPECTION**

Push the big end of the conrod to one side and measure the side clearance with a thickness gauge.

If the clearance exceeds the limit, replace the crankshaft assembly with a new one or bring the deflection and the side clearance within the service limit by replacing the worn parts (conrod, crank pin bearing, crank pin, etc.) with the new ones.

**DATA** Conrod big end side clearance:  
Service Limit: 1.0 mm (0.04 in)

**TOOL** 09900-20803: Thickness gauge

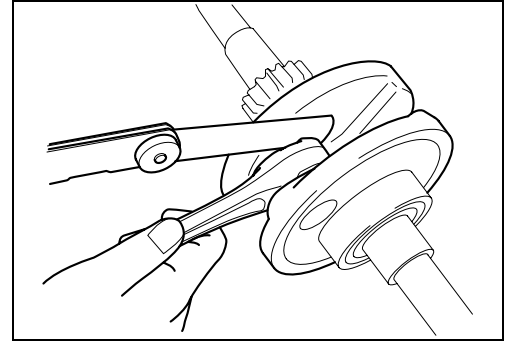
**CRANKSHAFT RUNOUT**

Support the crankshaft with V-blocks as shown, with the two end journals resting on the blocks.

Position the dial gauge, as shown, and rotate the crankshaft slowly to read the runout.

Replace the crankshaft if the runout is more than the service limit.

**DATA** Crankshaft runout:  
Service Limit: 0.08 mm (0.003 in)

**TOOL** 09900-20607: Dial gauge (1/100 mm)  
09900-20701: Magnetic stand  
09900-21304: V-block set (100 mm)

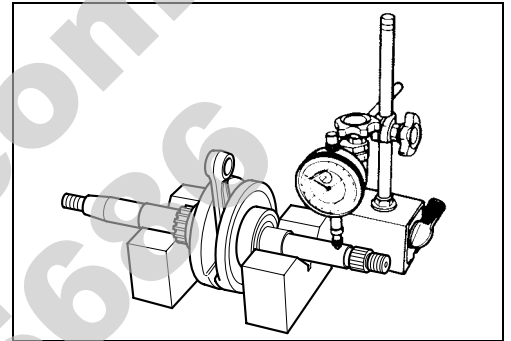
**CRANKSHAFT REASSEMBLY**

- When rebuilding the crankshaft, the width (A) between the webs should be within the specified range.

**DATA** Crank web to web width (A):  
Standard: 33.95 – 34.05 mm (1.337 – 1.341 in)

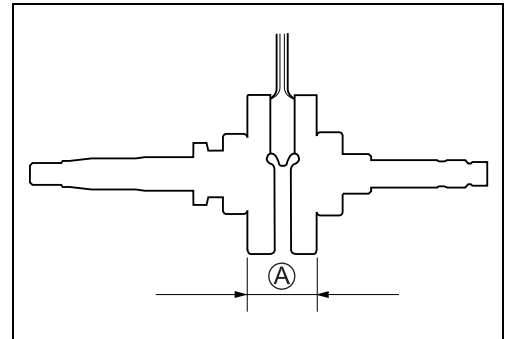
**CAM ROCKER ARM INSPECTION**

Inspect the cam rocker arms for abnormal wear or damage.

If they are worn or damaged, replace the cam rocker arm with a new one.

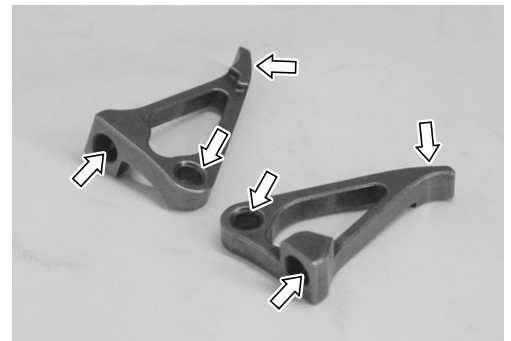

**PartShark.com**  
**877-999-5686**

# ENGINE

## CONTENTS

<b>ENGINE COMPONENTS REMOVABLE WITH ENGINE IN PLACE .....</b>	<b>3- 2</b>
<b>ENGINE CENTER .....</b>	<b>3- 2</b>
<b>ENGINE LEFT SIDE .....</b>	<b>3- 2</b>
<b>ENGINE RIGHT SIDE .....</b>	<b>3- 2</b>
<b>ENGINE REMOVAL AND INSTALLATION .....</b>	<b>3- 3</b>
<b>ENGINE REMOVAL .....</b>	<b>3- 3</b>
<b>ENGINE INSTALLATION .....</b>	<b>3- 6</b>
<b>POWER REDUCTION SPACER .....</b>	<b>3- 8</b>
<b>ENGINE DISASSEMBLY .....</b>	<b>3- 9</b>
<b>ENGINE COMPONENTS INSPECTION AND SERVICING .....</b>	<b>3-15</b>
<b>CYLINDER HEAD .....</b>	<b>3-15</b>
<b>ROCKER ARM PUSH ROD .....</b>	<b>3-20</b>
<b>CAMSHAFT ASSEMBLY .....</b>	<b>3-21</b>
<b>UPPER CRANKCASE/CYLINDER .....</b>	<b>3-21</b>
<b>PISTON AND PISTON RING .....</b>	<b>3-22</b>
<b>CONROD AND CRANKSHAFT .....</b>	<b>3-24</b>
<b>CAM ROCKER ARM .....</b>	<b>3-27</b>
<b>FINAL REDUCTION GEAR BOX AND CVT CASE .....</b>	<b>3-28</b>
<b>CVT CASE COVER .....</b>	<b>3-33</b>
<b>GENERATOR CASE .....</b>	<b>3-33</b>
<b>STARTER PINION .....</b>	<b>3-34</b>
<b>MOVABLE AND FIXED DRIVE AND DRIVEN FACE .....</b>	<b>3-35</b>
<b>RECOIL STARTER .....</b>	<b>3-43</b>
<b>ENGINE REASSEMBLY .....</b>	<b>3-47</b>

## FINAL REDUCTION GEAR BOX AND CVT CASE

### DISASSEMBLY

- Remove the snap ring ① and engine sprocket ②.
- Remove the drain plug ③ and gasket.
- Drain final reduction gear box oil.

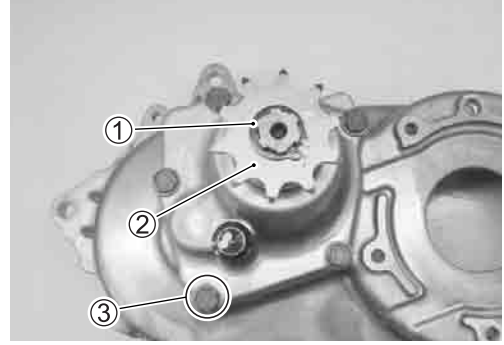

- Remove the final reduction gear box cover ④.

### NOTE:

*Loosen the final reduction gear box cover bolts little by little and diagonally.*



- Remove the dowel pins ⑤.
- Remove the washer ⑥ and ⑦.
- Remove the drive shaft ⑧.

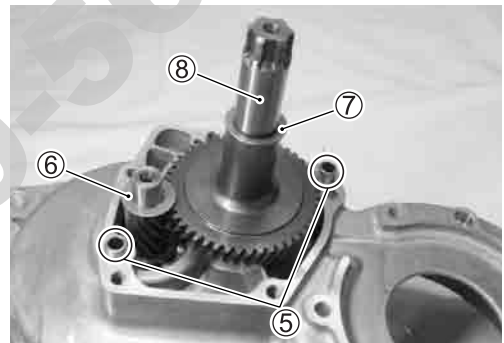

- Remove the counter shaft ⑨ with the special tool.

**TOOL** 09920-13120: Crankshaft separator

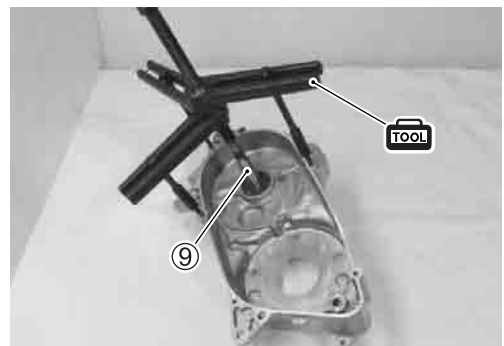

### COUNTER SHAFT INSPECTION

Inspect the counter shaft wear or damage.  
If it is worn or damaged, replace it with a new one.

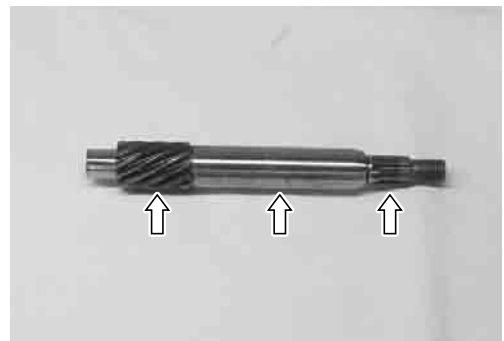

**DRIVE SHAFT INSPECTION**

Inspect the drive shaft for wear or damage.

If it is worn or damaged, replace it with a new one.

**BEARING INSPECTION**

Rotate the bearing inner race by finger to inspect for abnormal play, noise and smooth rotation while the bearings are in the those cases.

Replace the bearing in the following procedure if there is anything unusual.

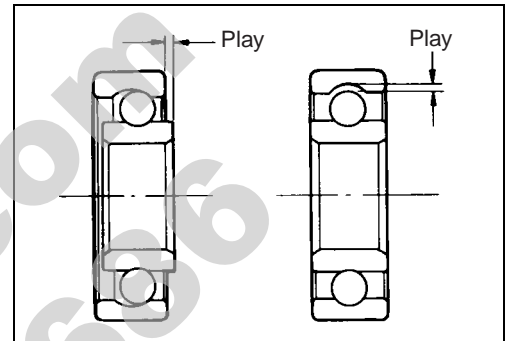

- Remove the oil seal ① with the special tool.

**TOOL** 09913-50121: Oil seal remover

**CAUTION**

The removed oil seal must be replaced with a new one.

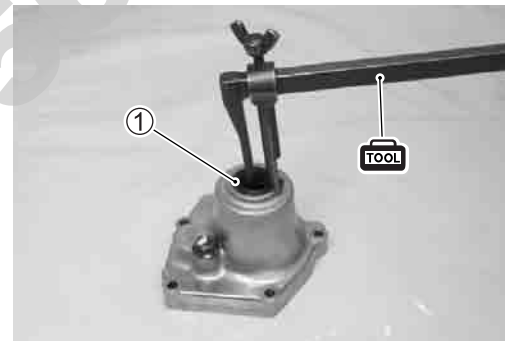

- Remove the oil seal ② with the special tool.

**TOOL** 09913-50121: Oil seal remover

**CAUTION**

The removed oil seal must be replaced with a new one.

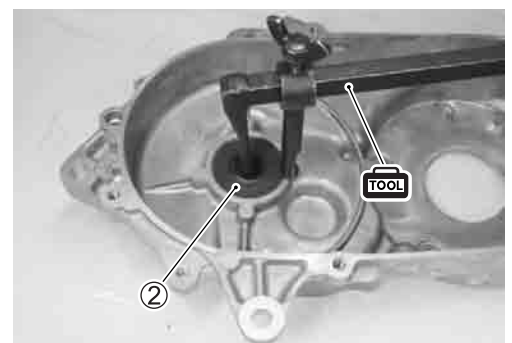

- Remove the bearings with the special tool.

**TOOL** 09913-70210: Bearing installer set  
09921-20240: Bearing remover set

**CAUTION**

The removed bearings should be replaced with new ones.

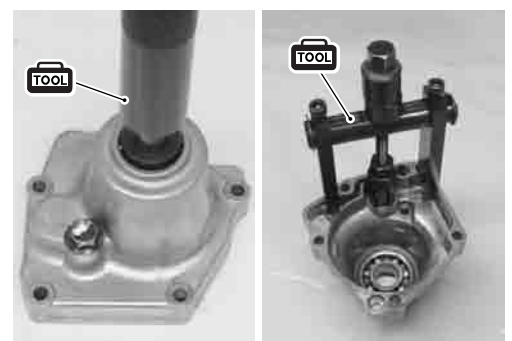



- Remove the snap ring ③.

**CAUTION**

The removed snap ring must be replaced with a new one.



- Remove the bearing ④ with the special tool.

**TOOL** 09913-70210: Bearing installer set

**CAUTION**

The removed bearing should be replaced with a new one.

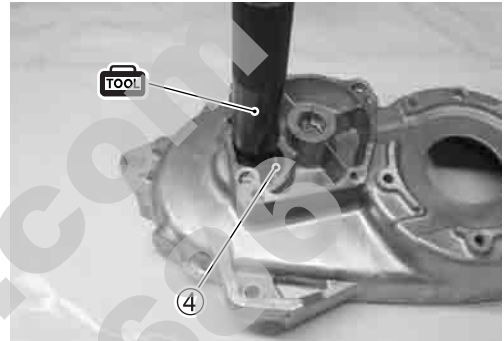

**BEARING INSTALLATION**

- Install the bearings with the special tool.

**TOOL** 09913-70210: Bearing installer set

**CAUTION**

Press-fit the bearing ① 1 – 1.5 mm (0.04 – 0.06 in) from the end surface.

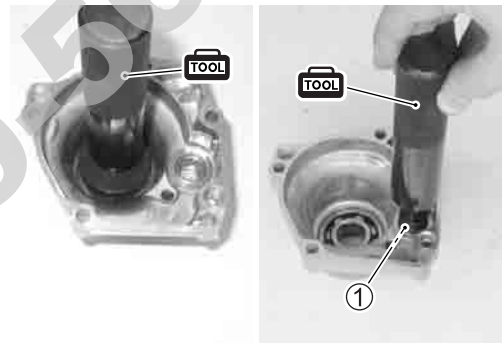

- Apply SUZUKI SUPER GREASE “A” to the bearing ①.

**FAH** 99000-25010: SUZUKI SUPER GREASE “A” or equivalent

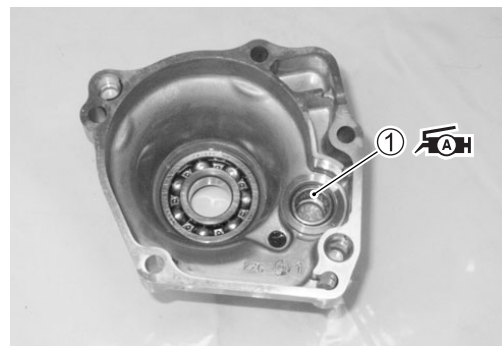

- Install the oil seal ② with the special tool.

**TOOL** 09913-70210: Bearing installer set

- Apply SUZUKI SUPER GREASE “A” to the oil seal lip.

**FAH** 99000-25010: SUZUKI SUPER GREASE “A” or equivalent

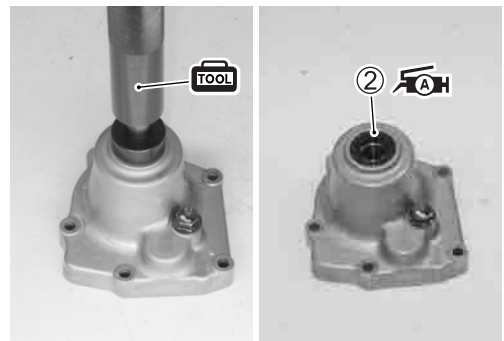

- Install the bearing ③ with the special tool.

 **09913-70210: Bearing installer set**

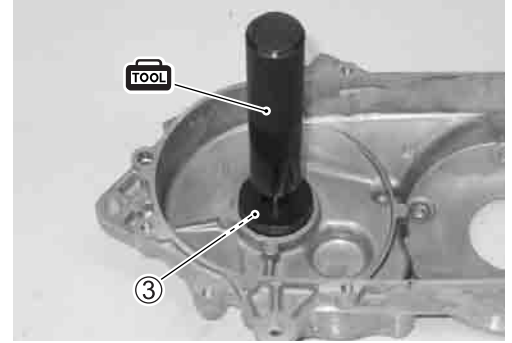

- Install the snap ring ④ securely.

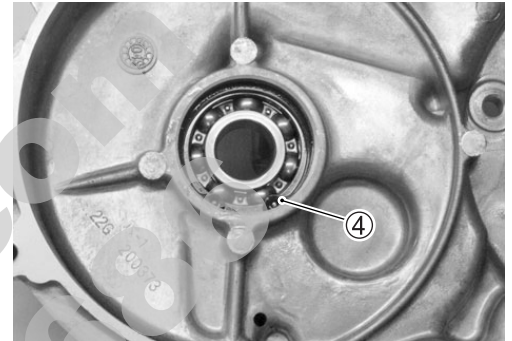

- Install the oil seal ⑤ with the special tool.

 **09913-70210: Bearing installer set**

- Apply SUZUKI SUPER GREASE "A" to the oil seal lip.

 **99000-25010: SUZUKI SUPER GREASE "A" or equivalent**

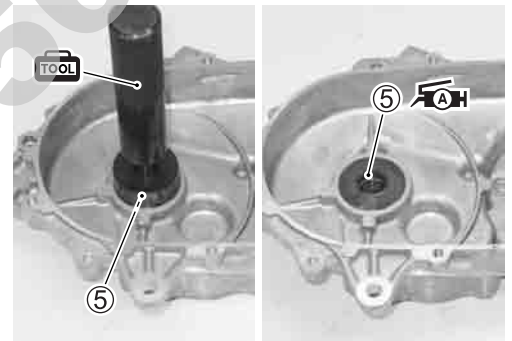

### BUSHING INSPECTION

Inspect the CVT case bushing for wear or damage.  
If anything unusual is found, replace the bushing with a new one.

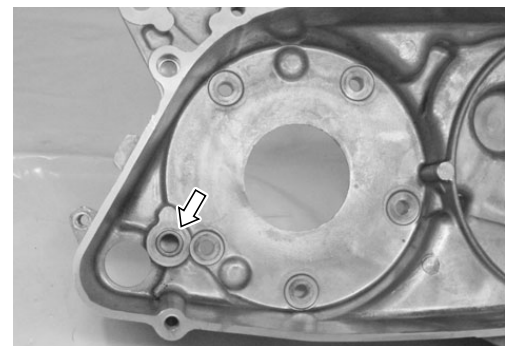

### REASSEMBLY

- Install the counter shaft ① into the CVT case with a plastic mallet.

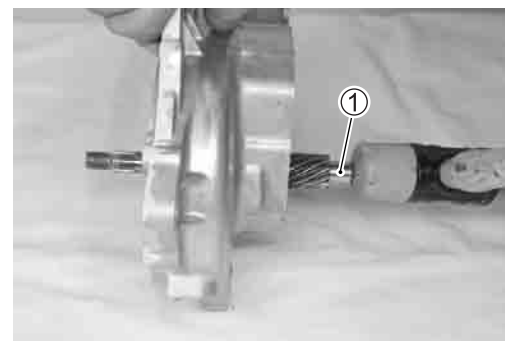

- Apply MOLYBDENUM OIL SOLUTION to the inside of the drive shaft journal.

**MOLYBDENUM OIL SOLUTION**

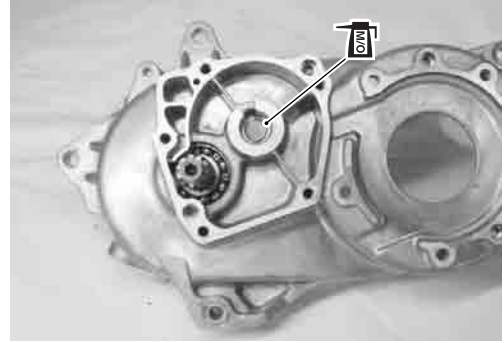

- Install the washer ② to the drive shaft.



- Install the drive shaft ③ to the CVT case.
- Install the washer ④ and ⑤.
- Install the dowel pins ⑥.

**CAUTION**

Apply final reduction gear box oil to the gears.

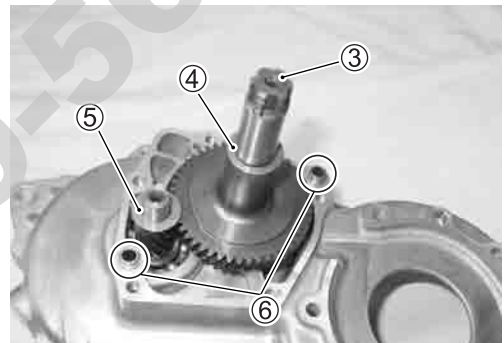

- Apply SUZUKI BOND "1215" to the final reduction gear box cover matching surface.

**1215 99000-31110: SUZUKI BOND "1215" or equivalent**

**NOTE:**

- \* Make surfaces free from moisture, oil, dust and other foreign materials.
- \* Spread on surfaces thinly to form an even layer, and assemble the cover within few minutes.

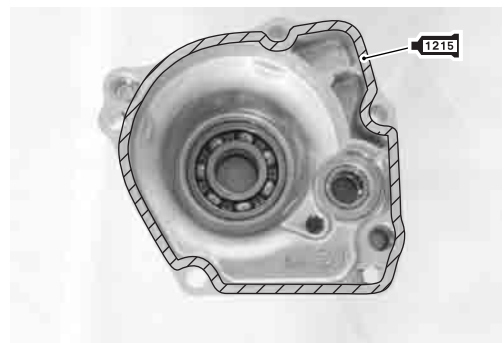

- Tighten the final reduction gear box cover bolts and drain plug ⑦ to the specified torque.

**Final reduction gear box cover bolt:**

**11 N·m (1.1 kgf-m, 8.0 lb-ft)**

**NOTE:**

Tighten the drain plug ⑦ together with the new gasket.

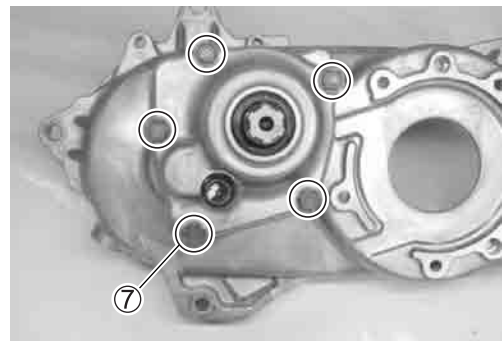

- Install the engine sprocket ⑧.
- Install the snap ring ⑨.

**CAUTION**

The removed snap ring must be replaced with a new one.

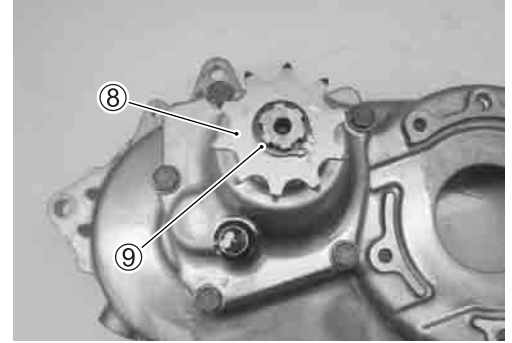
**CAUTION**

When installing a new snap ring, pay attention to the direction of the snap ring. Fit it to the side where the thrust is as shown in the illustration.

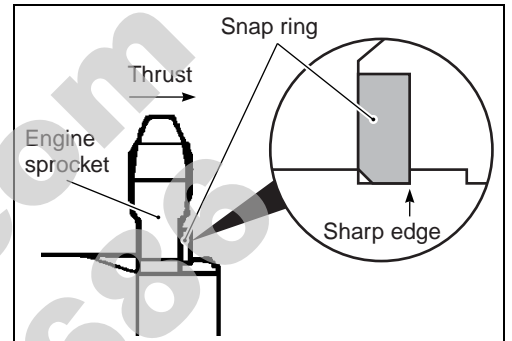
**CVT CASE COVER****BUSHING INSPECTION**

Inspect the CVT case cover bushing for wear or damage. If anything unusual is found, replace the bushing or CVT case cover.

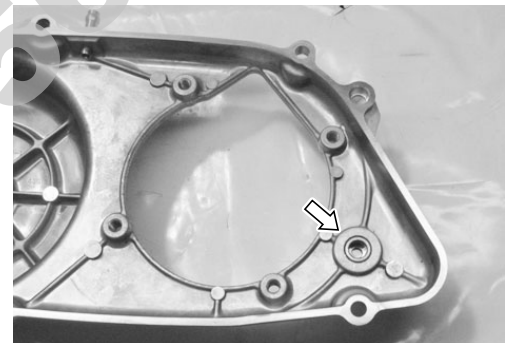
**GENERATOR CASE****BUSHING INSPECTION**

Inspect the bushing ① for wear or damage. If any defects are found, replace it with a new one.

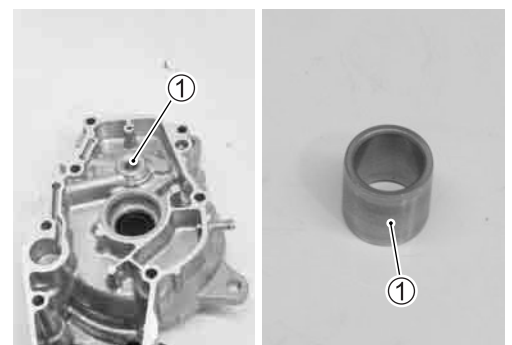
**OIL SEAL INSPECTION**

Damage to the lip of the oil seal may result in leakage of the fuel-air mixture or gear oil. Inspect the oil seal and if it is damaged, replace it with a new one.

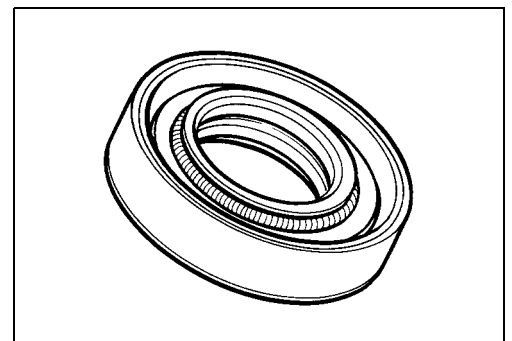

- Remove the oil seal ① with the special tool.

 09913-70210: Bearing installer set

**CAUTION**

The removed oil seal must be replaced with a new one.



- Install the oil seal ② with the special tool.

 09913-70210: Bearing installer set

- Apply SUZUKI SUPER GREASE "A" to the oil seal lip.

 99000-25010: SUZUKI SUPER GREASE "A" or equivalent

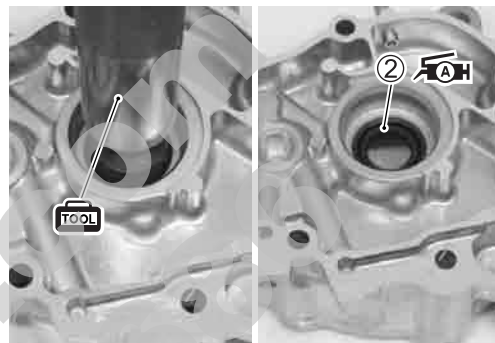

## STARTER PINION

### INSPECTION

- Check that the gear ① rotates in the direction ① when holding the gear ②.
- Check that the gear ① rotates in the direction ② and ③ when holding the gear ②.
- If anything unusual is found, replace the starter pinion with a new one.

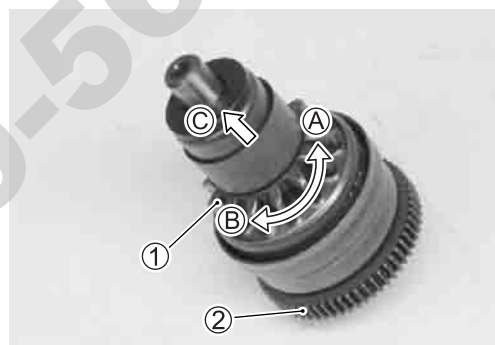



## MOVABLE AND FIXED DRIVE AND DRIVEN FACE

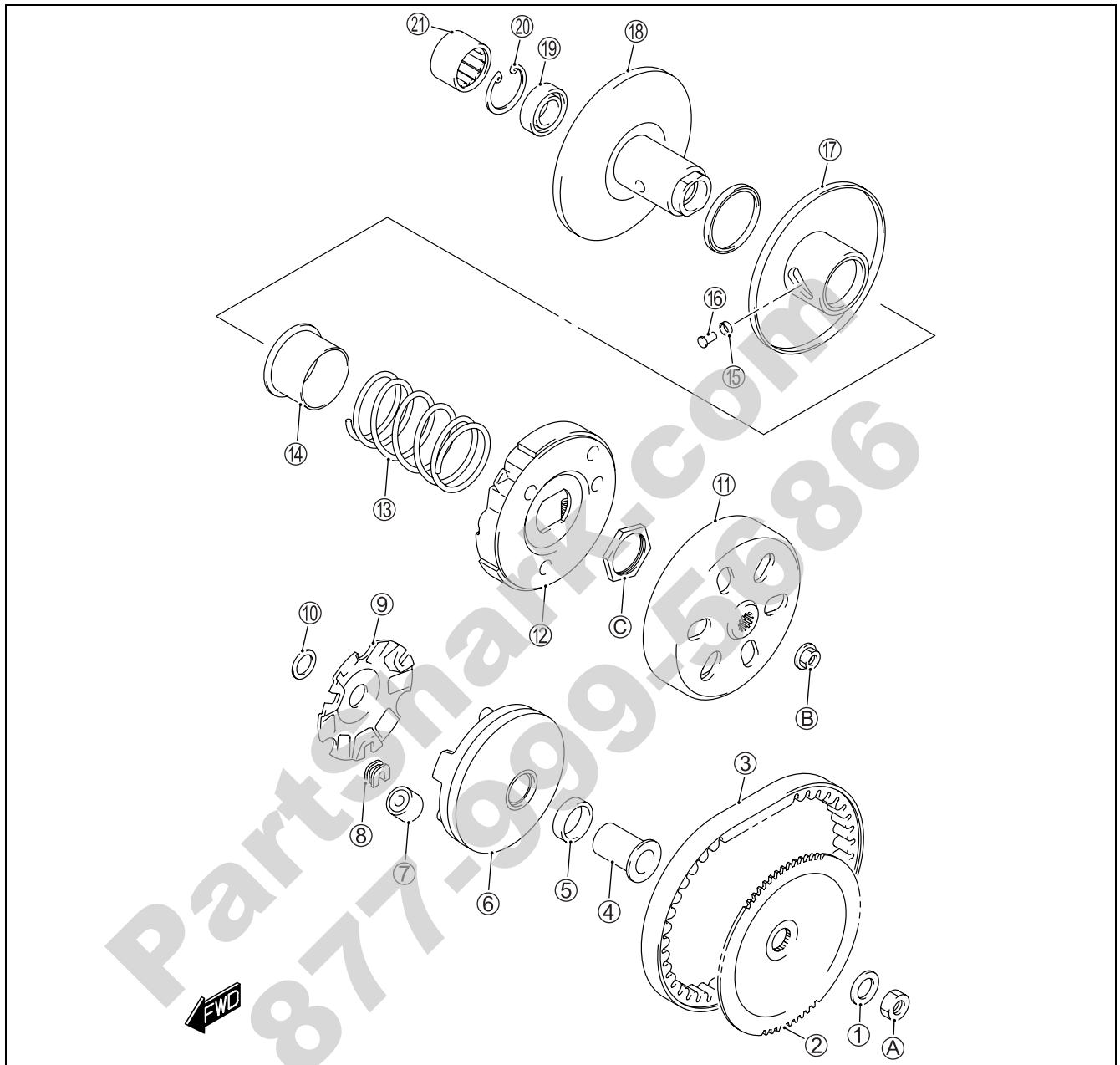

①	Concaved washer	⑬	Movable driven face spring
②	Fixed drive face	⑭	Movable driven face spring seat
③	Drive belt	⑮	Roller
④	Movable drive spacer	⑯	Pin
⑤	Power reduction spacer	⑰	Movable driven face
⑥	Movable drive face	⑱	Fixed driven face
⑦	Roller	⑲	Bearing
⑧	Damper	⑳	Snap ring
⑨	Movable drive face plate	㉑	Needle bearing
⑩	Washer	A	Fixed drive face nut
⑪	Clutch housing	B	Clutch housing nut
⑫	Clutch shoe	C	Clutch shoe nut



ITEM	N-m	kgf-m	lb-ft
A (Initial)	13	1.3	9.5
A (Final)	50	5.0	36.0
B	50	5.0	36.0
C	60	6.0	43.5

**MOVABLE DRIVE DISASSEMBLY**

- Remove the movable drive face plate ① and dampers ②.

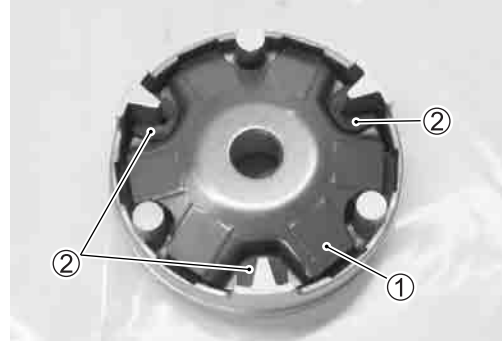

- Remove the rollers ③.

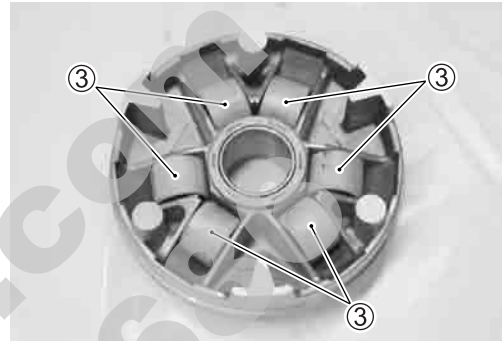
**SPACER INSPECTION**

Inspect the movable drive spacer ① and power reduction spacer ② for any wear or damage.

If they are worn or damaged, replace them with new ones.

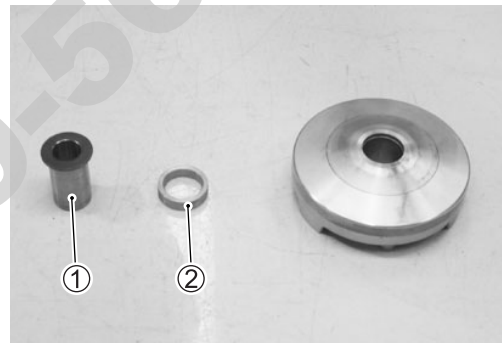
**MOVABLE AND FIXED DRIVE FACE INSPECTION**

Inspect the drive face for any abnormal condition such as stepped wear or discoloration caused by burning.

If any defects are found, replace them with new ones.

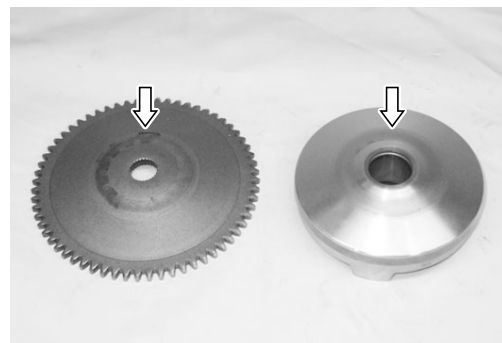
**ROLLER INSPECTION**

Inspect each roller and their sliding surface for wear or damage. If any defects are found, replace the rollers as a set.

**NOTE:**

*The rollers must always be changed as a set.*

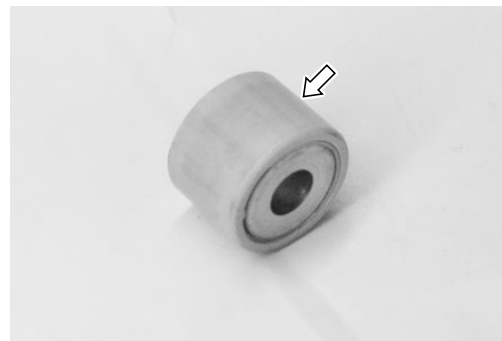

**DAMPER INSPECTION**

Inspect the dampers for wear or damage.

If any defects are found, replace the dampers with new ones.

**REASSEMBLY**

- Position the rollers ① on the movable drive face ②.
- Mount the dampers ③ on the movable drive face plate ④.
- Check that the rollers ① are in normal position in the movable drive face ②.
- Position the movable drive face plate ④ on the movable drive face ②.

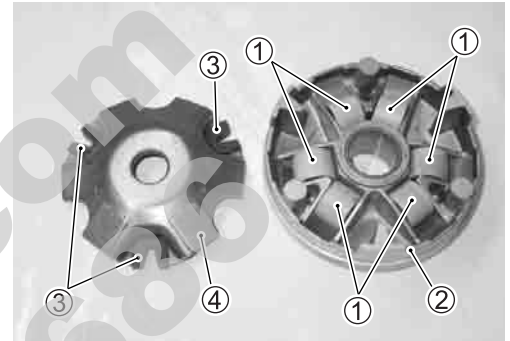
**CLUTCH SHOE/MOVABLE DRIVEN FACE DISASSEMBLY**

- Hold the clutch shoe assembly ① with the special tool.

**TOOL** 09930-40113: Rotor holder

- Loosen the clutch shoe nut ②.

**⚠ WARNING**

**Do not remove the clutch shoe nut before attaching the clutch spring compressor.**

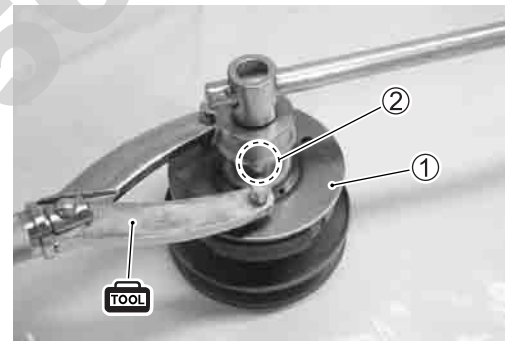

- Attach the special tool to the clutch shoe/movable driven face assembly and compress the clutch shoe assembly by turning in the special tool handle ②.

**TOOL** 09922-31420: Clutch spring compressor

- Remove the clutch shoe nut ③.

**⚠ WARNING**

**Since a high spring force applies to the clutch shoe assembly, care must be used so as not to cause the clutch shoe assembly and movable driven face to come off abruptly.**

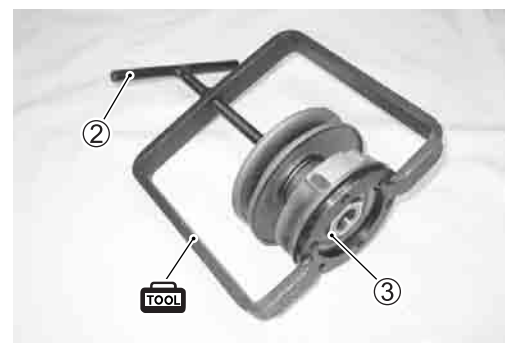



- Loosen the special tool handle slowly and remove the clutch shoe assembly ④ and spring ⑤.

**CAUTION**

Do not attempt to disassemble the clutch shoe assembly.

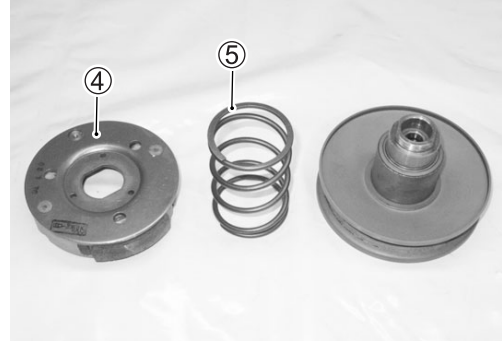

- Remove the movable driven face spring seat ⑥.

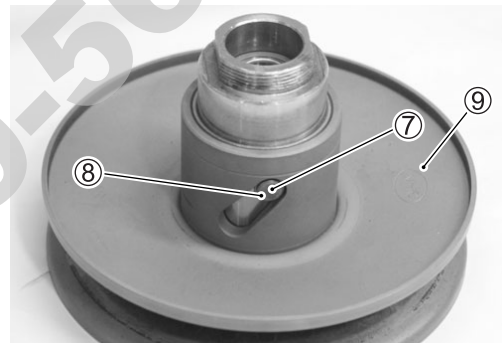

- Remove the pins ⑦ together with rollers ⑧.
- Remove the movable driven face ⑨.

**INSPECTION**

Inspect the movable driven face metal ① for wear or damage. If anything unusual such as scratches in the movable driven face metal ①, replace it with a new one.

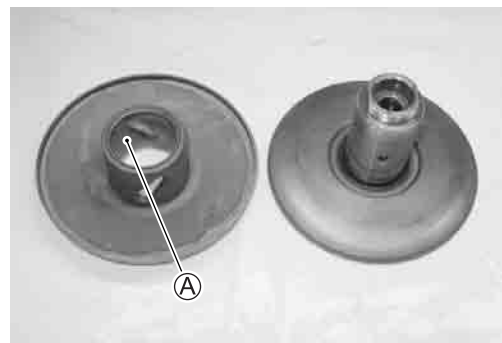

Inspect the rollers and pins for abnormal wear or damage. If they are worn or damaged, replace them with new ones.

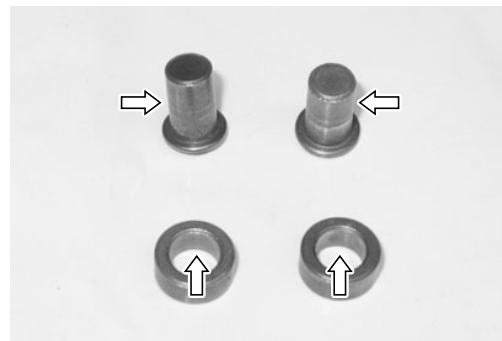

**BEARING INSPECTION**

Rotate the bearing inner race by finger to inspect for abnormal play, noise and smooth rotation while the bearing is in the fixed driven face.

Replace the bearing in the following procedure if there is anything unusual.

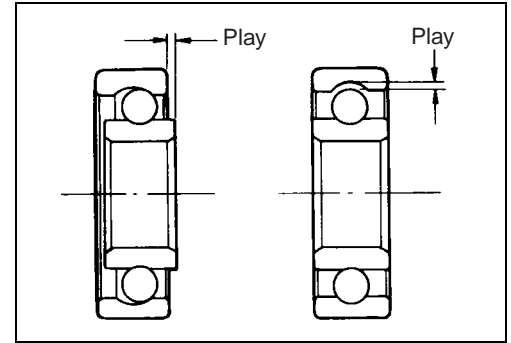

- Remove the needle bearing ① with the special tool.

**TOOL** 09921-20240: Bearing remover set

**CAUTION**

The removed bearing should be replaced with a new one.

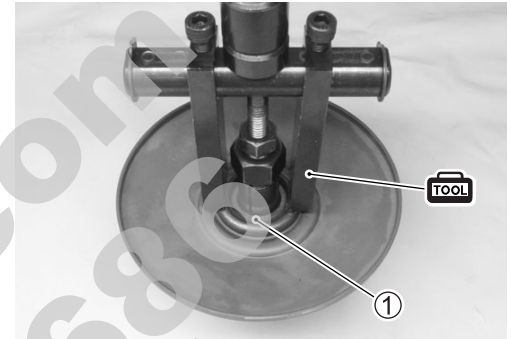

- Remove the snap ring ②.

**CAUTION**

The removed snap ring must be replaced with a new one.

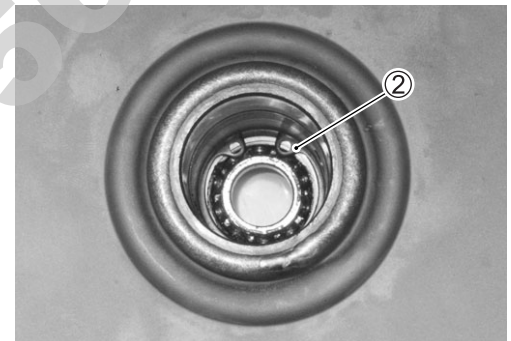

- Remove the bearing ③ with the special tool.

**TOOL** 09913-70210: Bearing installer set

**CAUTION**

The removed bearing should be replaced with a new one.

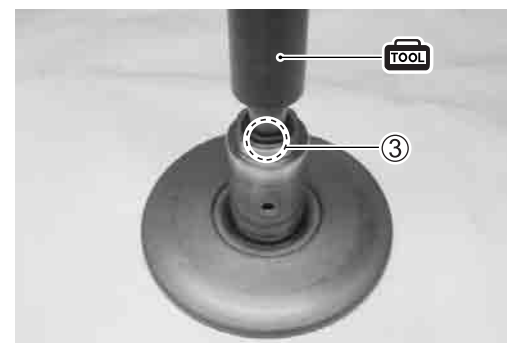
**CLUTCH SHOE INSPECTION**

Inspect the boss and centrifugal weight fulcrum sections for looseness, damage and operation.

Inspect the clutch shoe for damage and fouling with oil on the surface.

If any abnormality is found, replace the clutch shoe assembly with a new one.

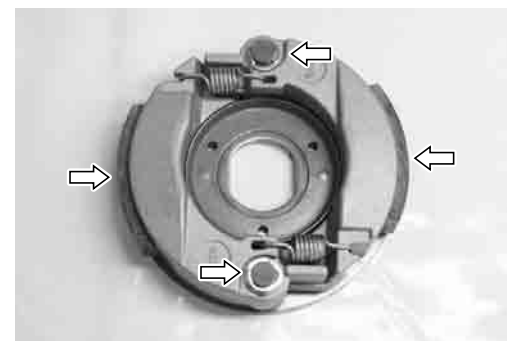

Measure the thickness of clutch shoe at the center position.  
If the thickness is less than the service limit, replace the clutch shoe assembly with a new one.

**DATA** Clutch shoe thickness:  
Service Limit: 3.0 mm (0.12 in)

**TOOL** 09900-20102: Vernier calipers

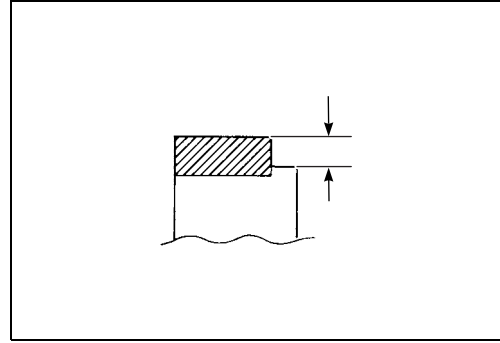

### CLUTCH HOUSING INSPECTION

Inspect the clutch housing for any abnormal surface damage.  
Measure the inside diameter of the clutch housing.  
If the measurement exceeds the service limit, replace the clutch housing with a new one.

**DATA** Clutch housing I.D.:  
Service Limit: 110.5 mm (4.35 in)

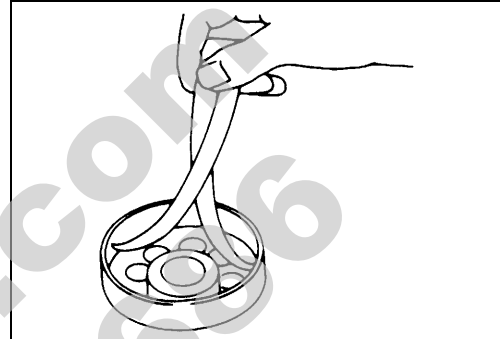

### MOVABLE DRIVEN FACE SPRING INSPECTION

Measure the movable driven face spring free length with a vernier calipers.  
If the length is less than the service limit, replace the spring with a new one.

**DATA** Movable driven face spring free length:  
Service Limit: 73.0 mm (2.87 in)

**TOOL** 09900-20102: Vernier calipers

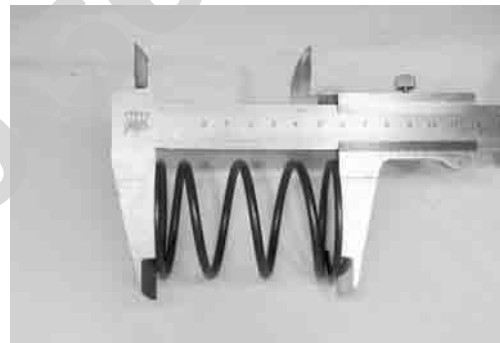

### DRIVE BELT

Inspect that the drive belt is free from any greasy substance.  
Inspect the contact surface of the drive belt for cracks or damage and measure the width of the drive belt with a vernier calipers.  
If any defects are found or the measurement exceeds the service limit, replace the drive belt with a new one.

#### CAUTION

If grease or oil is present on the surface of the drive belt, degrease the belt thoroughly.

**DATA** Drive belt width:  
Service Limit: 14.9 mm (0.59 in)

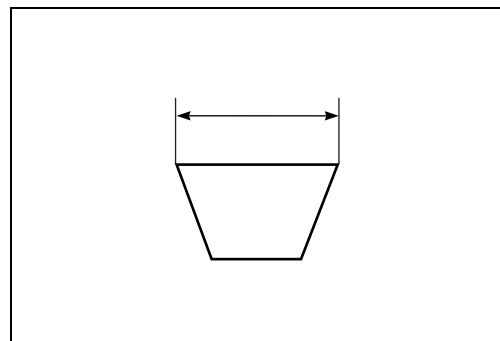
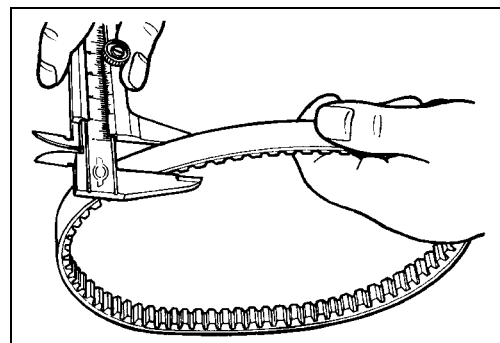

**REASSEMBLY**

- Install the bearing ① to the fixed driven face ② with a suitable spacer.

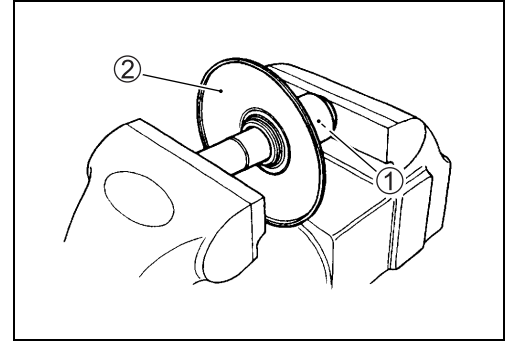

- Install the snap ring ③.

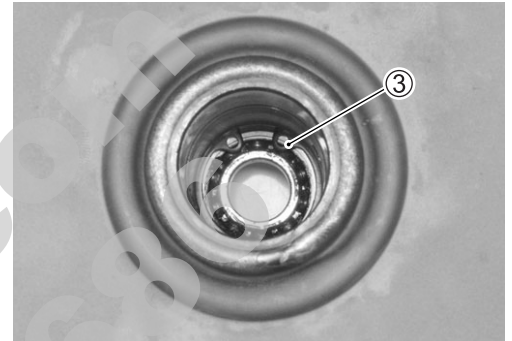

- Install the needle bearing ④ with a suitable spacer.

**CAUTION**

**Position the needle bearing with its punch mark outside.**

- Apply SUZUKI SUPER GREASE "A" to the needle bearing.
-  99000-25010: SUZUKI SUPER GREASE "A" or equivalent

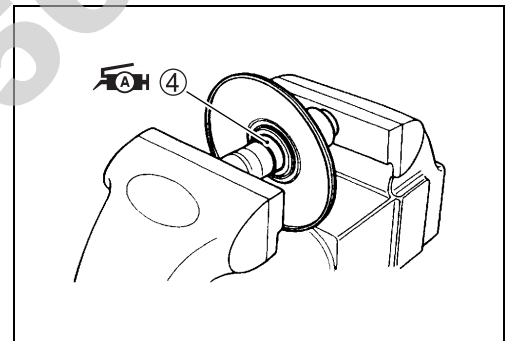

- Install the movable driven face ⑤ onto the fixed driven face ②.



- Install the pins ⑥ to the pin hole with the rollers ⑦ fitted.
- Install the movable driven face spring seat ⑧ to the movable driven face ⑤ securely.
- Install the spring ⑨ and clutch shoe assembly ⑩ onto the movable driven face ⑤.

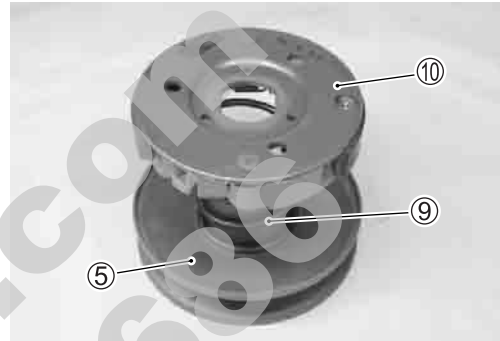
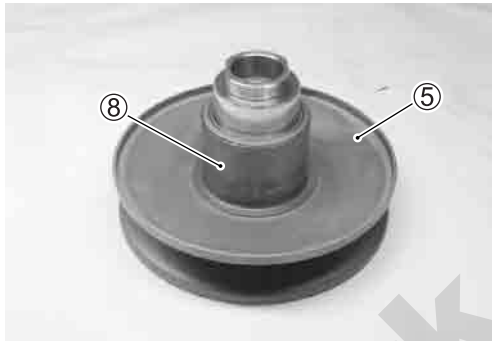
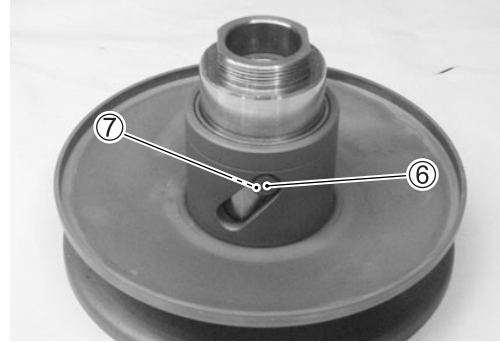

- Compress the spring ⑨ with the special tool.

**TOOL** 09922-31420: Clutch spring compressor

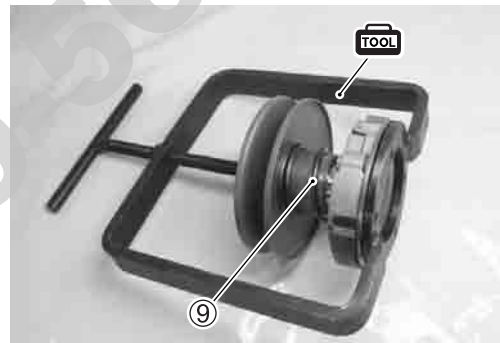

**CAUTION**

Align the flats **A** of the fixed driven face end and clutch shoe plate.

- Tighten the clutch shoe nut temporarily.
- Remove the special tool from the clutch shoe assembly.

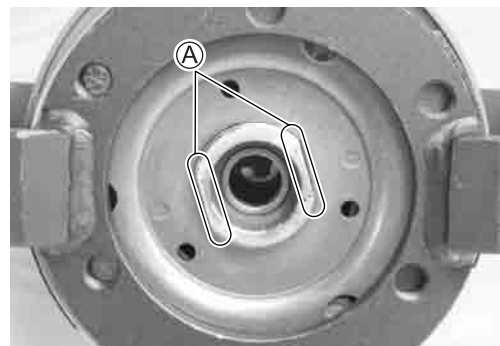

- Tighten the clutch shoe nut to the specified torque with the special tool.

**TOOL** 09930-40113: Rotor holder

**TOOL** Clutch shoe nut: 60 N-m (6.0 kgf-m, 43.5 lb-ft)

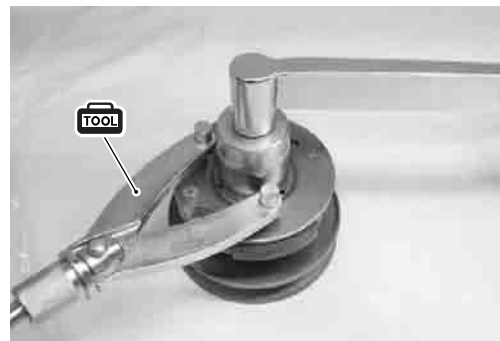

## RECOIL STARTER

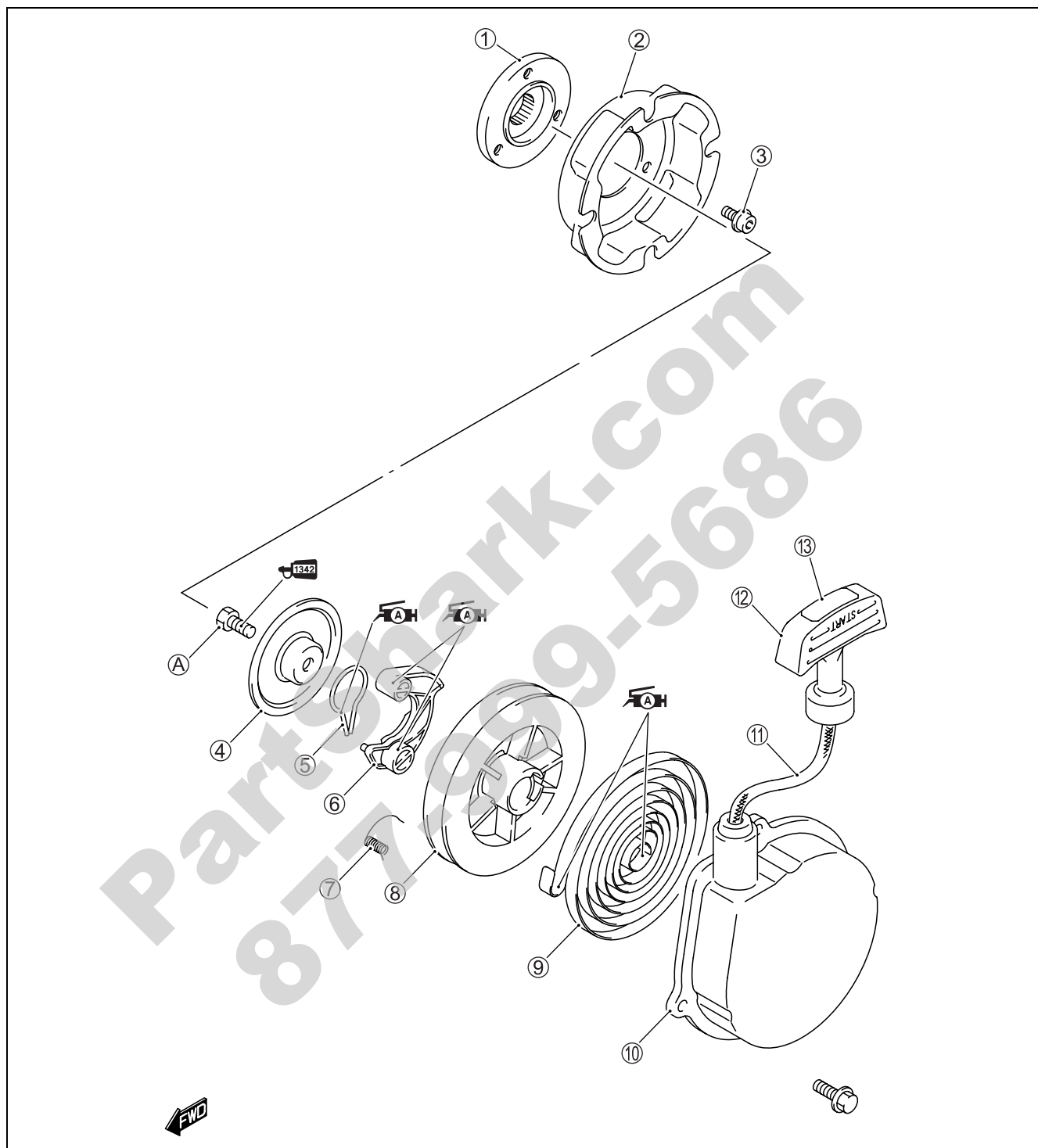

①	Starter cup spacer	⑧	Reel
②	Starter cup	⑨	Spiral spring
③	Starter cup bolt	⑩	Starter case
④	Friction plate	⑪	Rope
⑤	Friction spring	⑫	Knob
⑥	Ratchet	⑬	Cap
⑦	Return spring	A	Recoil starter friction plate bolt



ITEM	N·m	kgf·m	lb·ft
A	5.4	0.54	4.0



**DISASSEMBLY**

- Remove the bolt ① and friction plate ②.

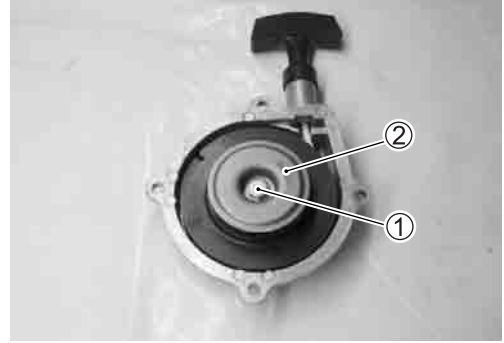

- Remove the ratchet (3) and return spring (4).

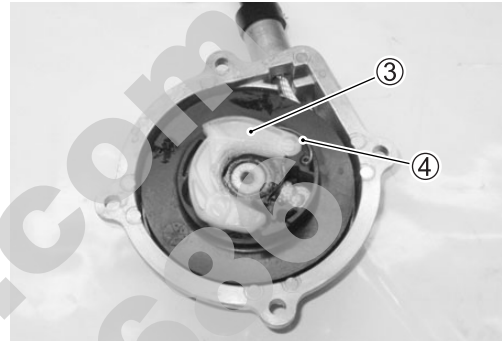

- Remove the cap (5) from the knob (6).
- Untie a knot at the rope.



- Hook the rope to the groove (A) of the reel (7).
- Turn the rope on the reel (7) properly.
- Remove the reel (7).

**⚠ WARNING**

**Wear hand and eye protection when removing the reel, since the spiral spring may quickly unwind and cause an injury.**

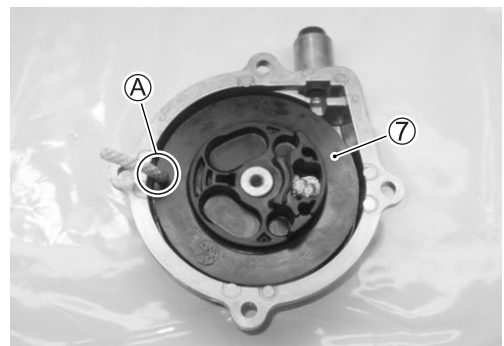

- Remove the spiral spring (8) from the recoil starter case (9).

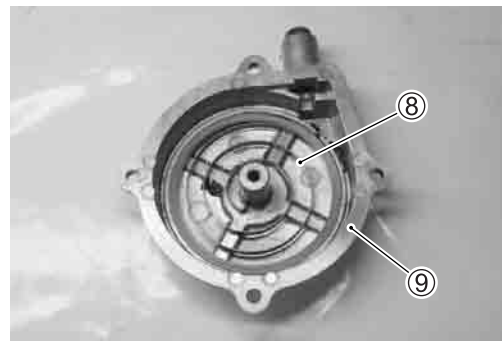



**REASSEMBLY**

Reassemble the recoil starter in the reverse order of disassembly. Pay attention to the following points:

- When installing the spiral spring, hook the spiral spring end ① with the recoil starter case.

**⚠ WARNING**

**Wear hand and eye protection when installing the reel, since the spiral spring may quickly unwind and cause an injury.**

- Apply SUZUKI SUPER GREASE "A" to the spiral spring.

 99000-25010: SUZUKI SUPER GREASE "A" or equivalent

- Turn the rope on the reel properly.
- After installing the spiral spring, engage the part ① of the reel with the spiral spring end ②.

- Hook the rope onto the hook part ③ of the reel.
- Turn the reel counterclockwise three or four times with the rope.
- Lace the end of the rope through the recoil starter case hole ④.

- Tie a knot at the end of the rope.
- Install the cap ⑤ to the knob ⑥.

- Apply SUZUKI SUPER GREASE "A" to the sliding part of the ratchet and reel.

 99000-25010: SUZUKI SUPER GREASE "A" or equivalent

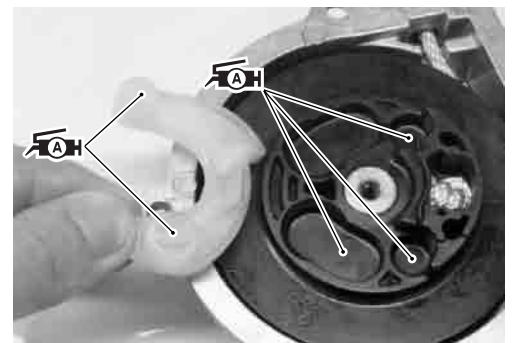
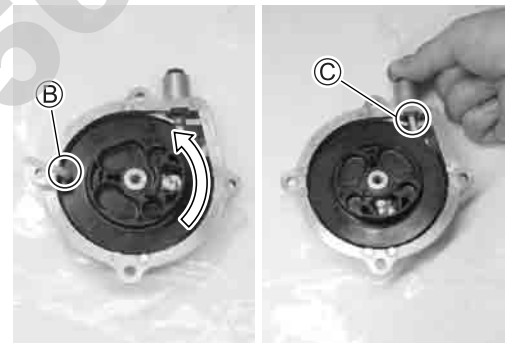
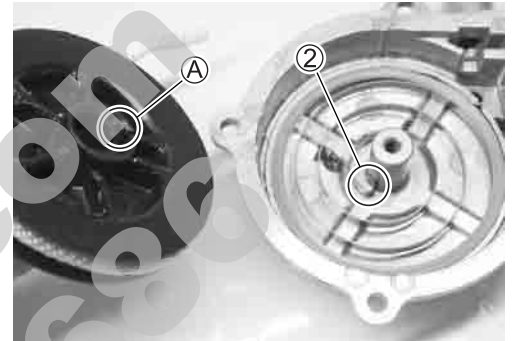
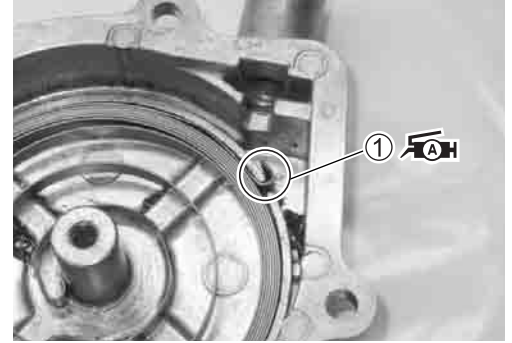

- Apply SUZUKI SUPER GREASE “A” to the return spring ⑤.

 99000-25010: SUZUKI SUPER GREASE “A” or equivalent

- Install the return spring ⑤.

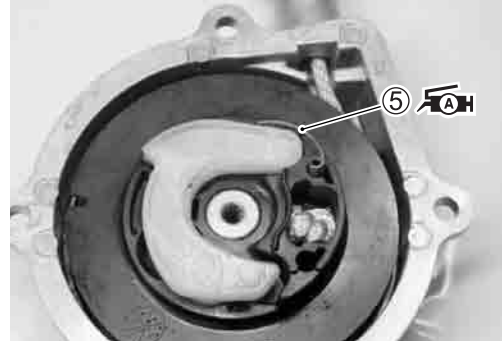

- Apply SUZUKI SUPER GREASE “A” to the sliding part of the friction spring ⑥ and ratchet.

 99000-25010: SUZUKI SUPER GREASE “A” or equivalent

- Align the friction spring ⑥ with the projection ① of the ratchet.

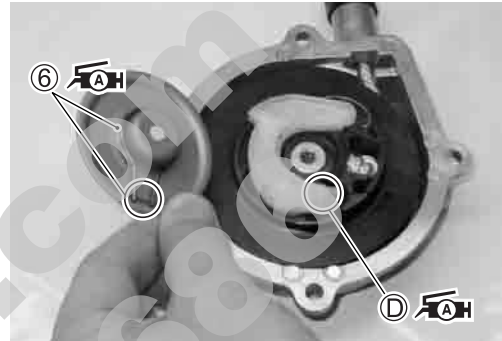

- Apply THREAD LOCK “1342” to the bolt ⑦.

- Tighten the bolt ⑦ to the specified torque.

 1342 99000-32050: THREAD LOCK “1342” or equivalent

 Recoil starter friction plate bolt:

5.4 N·m (0.54 kgf-m, 4.0 lb-ft)



- Pull the rope and check that the ratchet is pushed out.

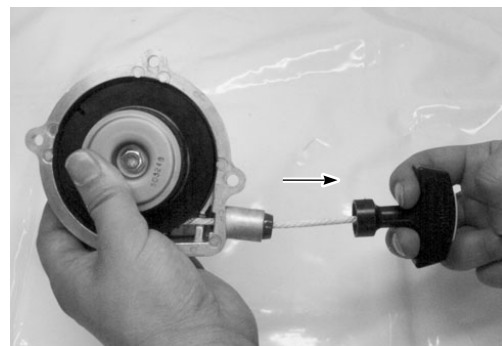

## ENGINE REASSEMBLY

Reassemble the engine in the reverse order of disassembly. Pay special attention to the following points:

**NOTE:**

Apply engine oil to each running and sliding surface before reassembling.

### PISTON RING AND PISTON

- Install the piston rings in the order of oil ring, 2nd ring and 1st ring.
- The first member to go into the oil ring groove is a spacer ①. After placing the spacer, fit the two side rails ②.

**NOTE:**

Side designations, top and bottom, are not applied to the spacer and side rails: Those can be positioned each either way.

**CAUTION**

When installing the spacer, be careful not to allow its two ends to overlap in the groove.

- Install the 2nd ring ④ and 1st ring ⑤.
- 1st ring ⑤ has letter "O" marked on the side. Be sure to bring the marked side to the top when fitting it to the piston.
- 2nd ring ④ has letter "R" marked on the side. Be sure to bring the marked side to the top when fitting it to the piston.

- Position the gaps of three rings as shown. Before inserting the piston into the cylinder, check that the gaps are so located.

- ④ 2nd ring, Lower side rail
- ⑤ Upper side rail
- ⑥ 1st ring, Spacer

- Apply engine oil to the piston pin surface and conrod small end when inserting.
- Install the piston and piston pin.
- Install the piston pin circlip ③.

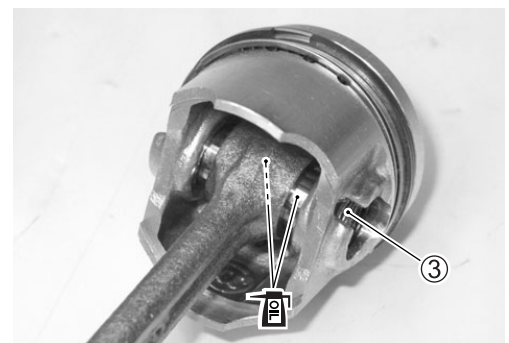
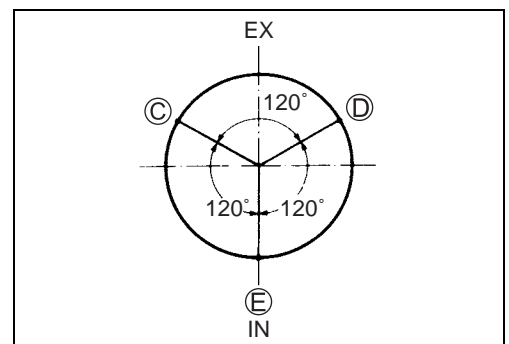
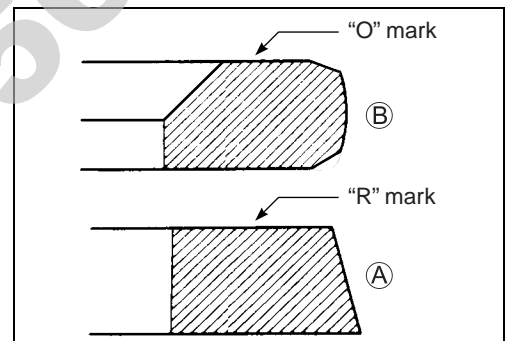
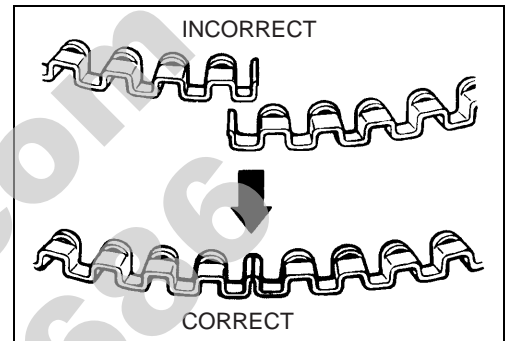
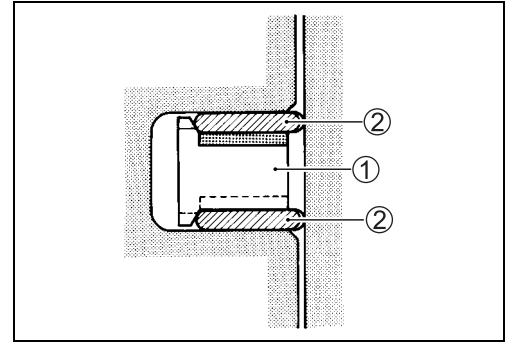

**CAUTION**

Use new piston pin circlips to prevent circlip failure which will occur with a bend one.

**NOTE:**

End gap of the circlip should not be aligned with the cutaway (F) in the piston pin bore.

**NOTE:**

When installing the piston (4), the punched mark (G) on the piston head is located to the exhaust side.

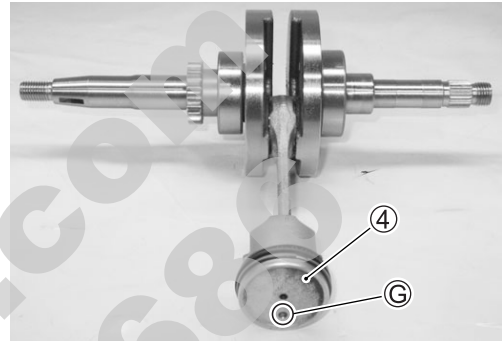
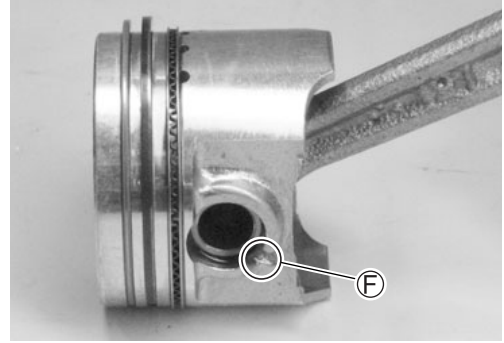
**CRANKSHAFT**

- Apply engine oil to the crankshaft bearing (1).
- Apply SUZUKI SUPER GREASE "A" to the oil seal lip.

 99000-25010: SUZUKI SUPER GREASE "A" or equivalent

- Install the oil seal (2) to the crankshaft.

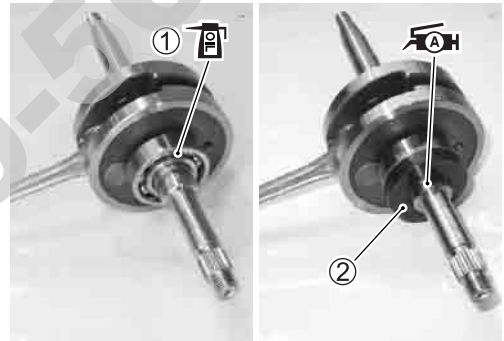

- Install the crankshaft bearing retainer (3) to the upper crankcase/cylinder.
- Apply engine oil to the cylinder.

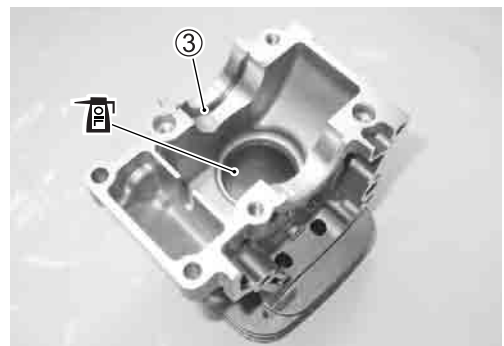

- Apply a small quantity of engine oil to the piston ring.
- Install the piston and crankshaft to the upper crankcase/cylinder.

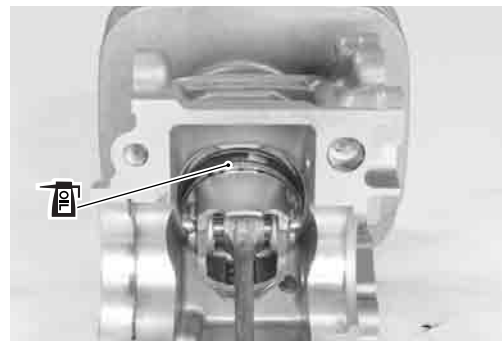

- Install the crankshaft ④ and dowel pins ⑤ to the upper crankcase/cylinder.

NOTE:

Apply engine oil to the bearing ⑥ balls and conrod big end ⑦.

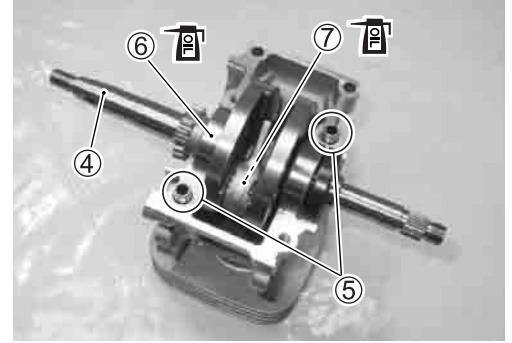

### CRANKCASE

- Apply SUZUKI BOND “1215” to the lower crankcase matching surface.

 99000-31110: SUZUKI BOND “1215” or equivalent

NOTE:

Use of SUZUKI BOND is as follows:

- \* Make surfaces free from moisture, oil, dust and other foreign materials.
- \* Spread on surfaces thinly to form an even layer, and assemble the crankcases within few minutes.

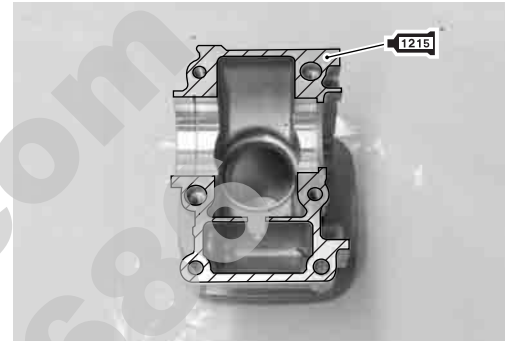

- Tighten the crankcase bolts to the specified torque.

 Crankcase bolt: 11 N·m (1.1 kgf·m, 8.0 lb-ft)

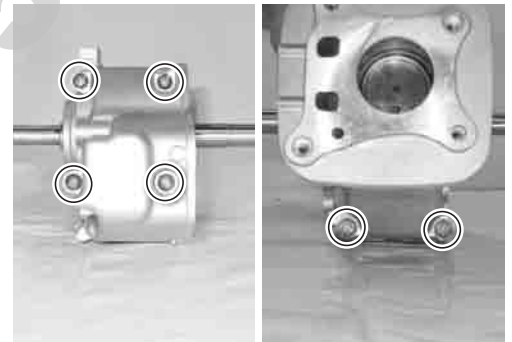

- Install the bushing ① to the upper crankcase/cylinder.
- Install the bushing ② to the generator case.

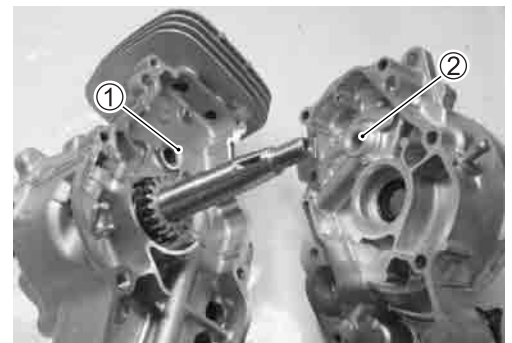



**CAM ROCKER ARM**

- Assemble the cam rocker arms ①, shaft ② and washer ③.

**NOTE:**

Align the hollows A of the cam rocker arm.

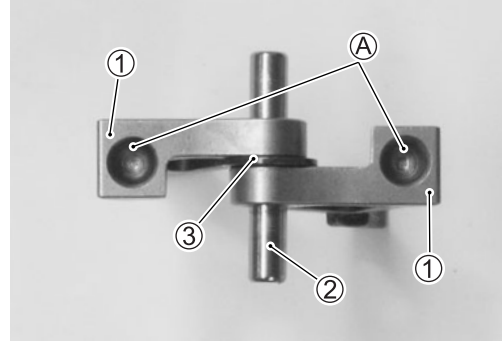

- Apply engine oil to the cam rocker arm shaft ④.
- Install the cam rocker arms ⑤, spring ⑥ and washer ⑦ to the upper crankcase/cylinder.
- Keep the rocker arms ⑤ open.

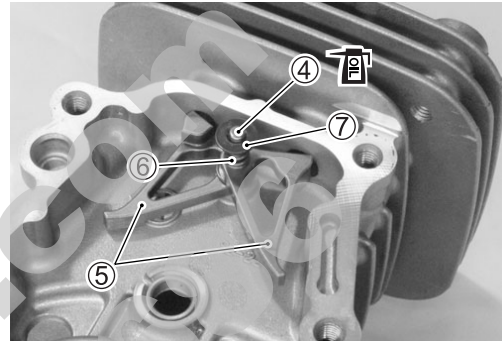
**CAMSHAFT ASSEMBLY**

- Install the camshaft assembly ① and washer ②.
- Align the hole A of the camshaft ① with the matching mark B on the cam drive gear ③.

**NOTE:**

Piston must be at TDC before installing the cam assembly.

- Apply SUZUKI BOND "1215" to the part shown in the photograph.

**1215** 99000-31110: SUZUKI BOND "1215" or equivalent

**NOTE:**

Make surfaces free from moisture, oil, dust and other foreign materials.

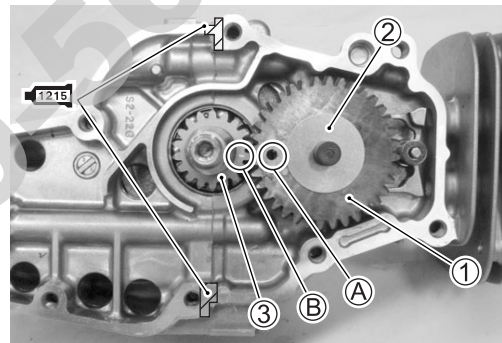
**GENERATOR CASE**

- Install the dowel pins ① and gasket ②.

**CAUTION**

- \* Apply engine oil to the gears.
- \* The removed gasket must be replaced with a new one.

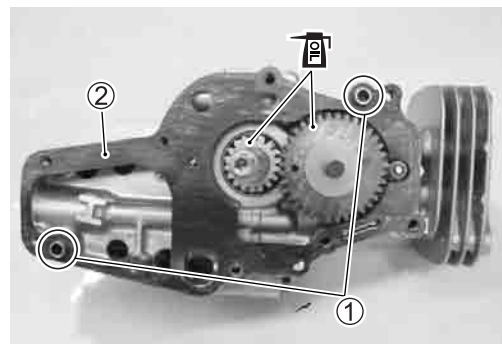

- Tighten the generator case bolts to the specified torque.

 **Generator case bolt: 11 N·m (1.1 kgf·m, 8.0 lb·ft)**

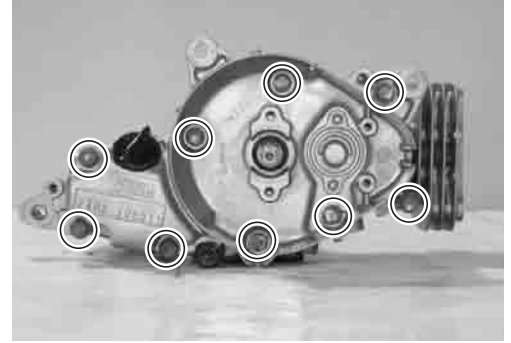

### CVT CASE

- Install the dowel pins ① and gasket ②.

#### CAUTION

The removed gasket must be replaced with a new one.

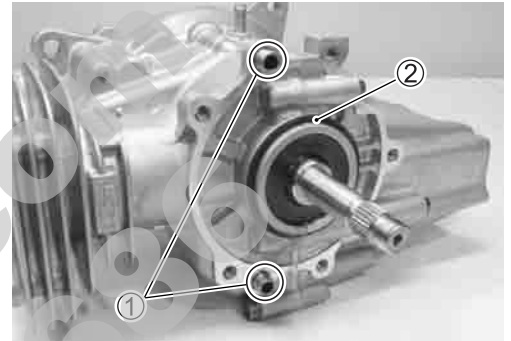

- Tighten the CVT case bolts to the specified torque.

 **CVT case bolt: 11 N·m (1.1 kgf·m, 8.0 lb·ft)**

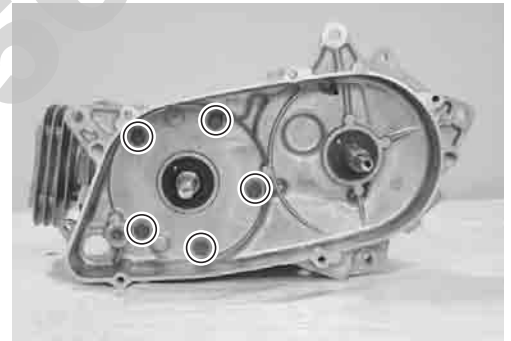

### MOVABLE DRIVEN FACE

- Install the drive belt ① to the movable driven face ②.

#### NOTE:

With the clutch shoe spring compressed by hands, install the drive belt ① between the movable driven face ② and fixed driven face.

#### CAUTION

- \* Degrease the drive belt contact surface (pulley face).
- \* Position the drive belt so that the arrow **A** points the engine rotating direction.

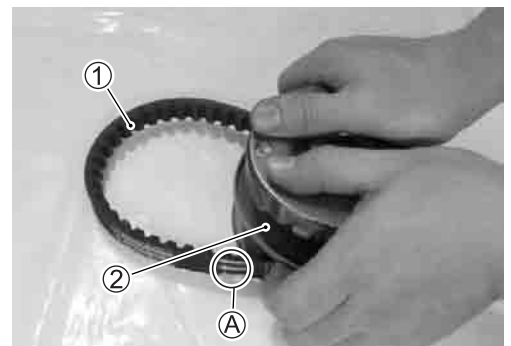



- Tighten the clutch housing nut ③ to the specified torque with the special tool.

**TOOL** 09930-40113: Rotor holder

**TOOL** Clutch housing nut: 50 N·m (5.0 kgf·m, 36.0 lb·ft)

**NOTE:**

*Degrease the inside of the clutch housing and clutch shoe.*

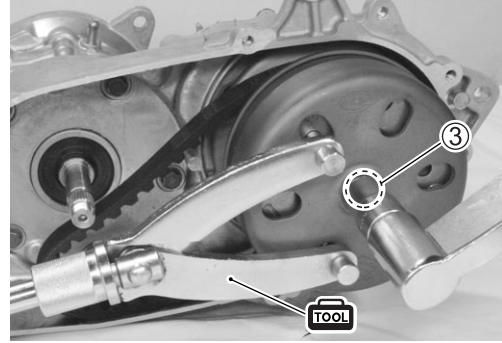

### MOVABLE DRIVE FACE

- Install the washer ①.

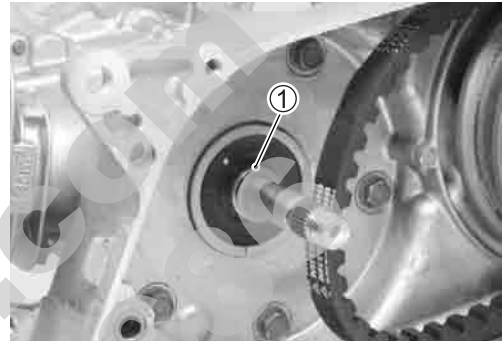

- Install the movable drive face assembly ② and fixed drive face ③.

**NOTE:**

*Degrease the drive belt contact surfaces.*

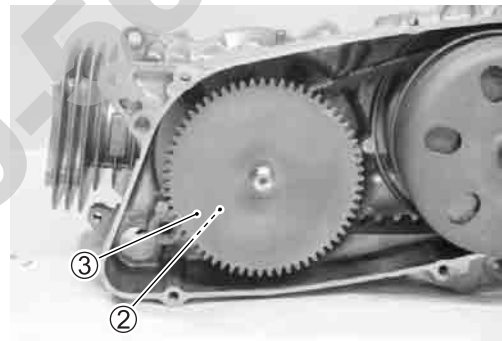

- Install the starter cup assembly ④, wave washer and fixed drive face nut ⑤.

**NOTE:**

*The concave side of the washer must face the starter cup ④.*

- Tighten the fixed drive face nut ⑤ to the specified torque with the special tool.

**TOOL** 09930-40113: Rotor holder

**TOOL** Fixed drive face nut:

**Initial:** 13 N·m (1.3 kgf·m, 9.5 lb·ft)

**Final:** 50 N·m (5.0 kgf·m, 36.0 lb·ft)

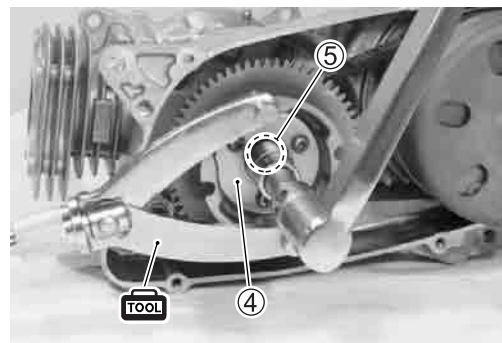

**NOTE:**

Turn the fixed drive face ③ until the drive belt is seated in and both the drive and driven faces will move together smoothly without slip.

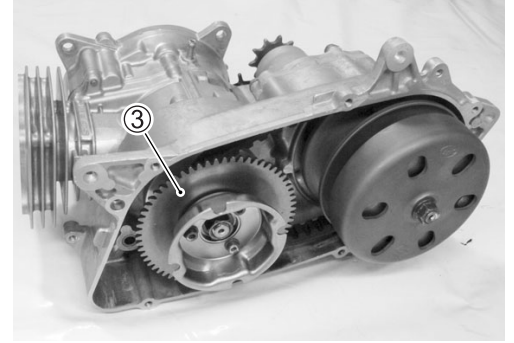
**CVT CASE COVER**

- Install the dowel pins ① and gasket ②.

**CAUTION**

The removed gasket must be replaced with a new one.

- Install the starter pinion ③.

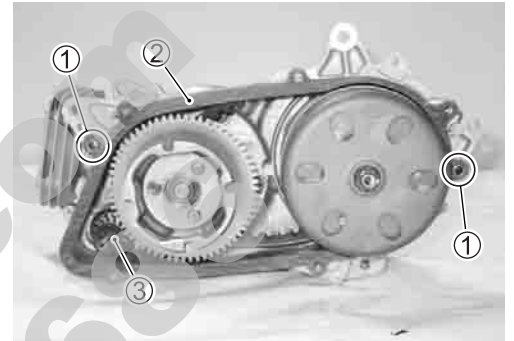

- Install the CVT case cover ④.
- Tighten the CVT case cover bolts to the specified torque.

**CVT case cover bolt: 11 N·m (1.1 kgf-m, 8.0 lb-ft)**

**NOTE:**

- \* Tighten the bolt ⑤ together with the clamp ⑥.
- \* Tighten the bolt ⑦ together with the earth terminal after remounting the engine.

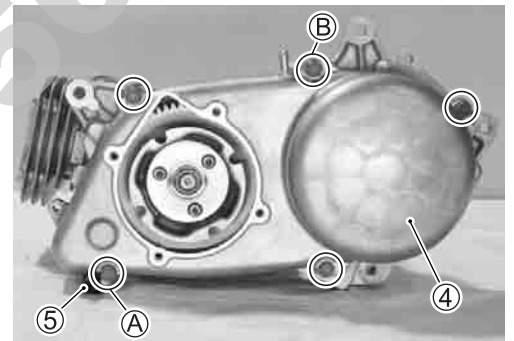
**GENERATOR ROTOR**

- Tighten the generator coil bolts ① and pick-up coil bolts ②.
- Pass the generator lead wire to the generator case groove ③.

**Generator coil bolt: 10 N·m (1.0 kgf-m, 7.0 lb-ft)**

**Pick-up coil bolt: 4.5 N·m (0.45 kgf-m, 3.0 lb-ft)**

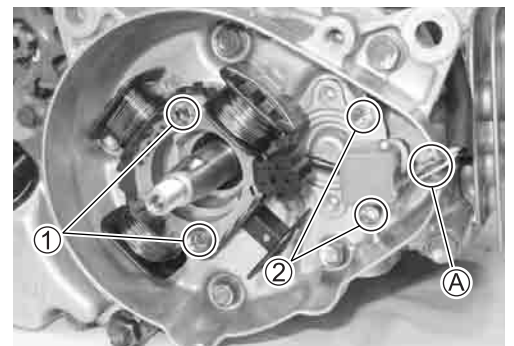

- Install the key ④.

**NOTE:**

Degrease the tapered portion of the crankshaft and also the rotor.

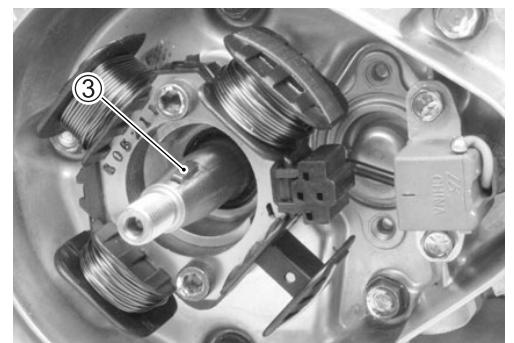

- Tighten the generator rotor nut ④ to the specified torque with the special tool.

**TOOL** 09930-40113: Rotor holder

**Generator rotor nut: 35 N·m (3.5 kgf·m, 25.5 lb·ft)**

**CAUTION**

Be careful not to damage the generator coil by the special tool.

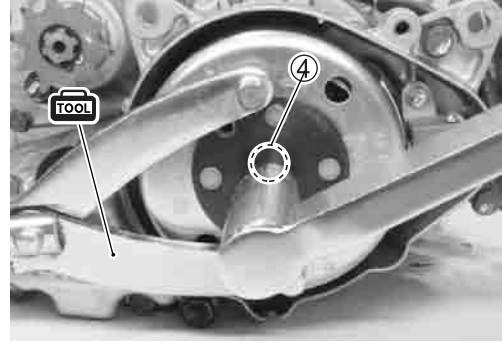

**STARTER MOTOR**

- Install the starter motor ①.

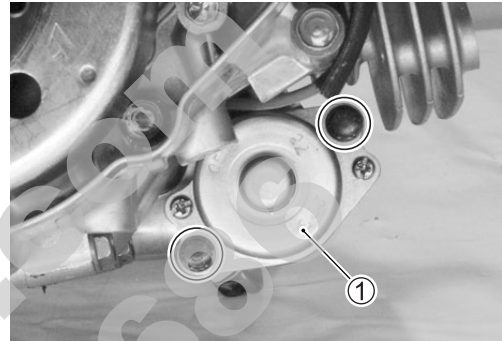

**CYLINDER HEAD**

- Apply MOLYBDENUM OIL SOLUTION to both ends of the push rods ①.

**MOLYBDENUM OIL SOLUTION**

- Install the push rods ① to the cam rocker arm hollows A.

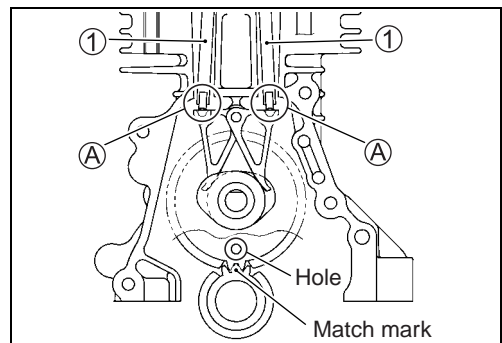
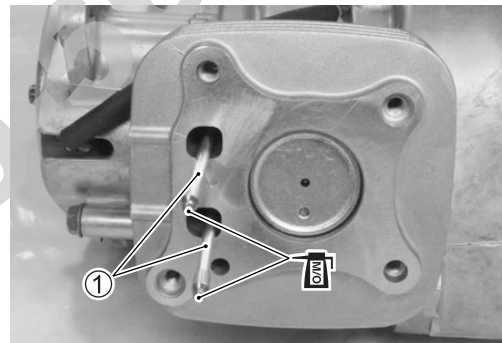

- Turn the crankshaft counterclockwise and align the line B on the generator rotor with the index mark C of the generator case.

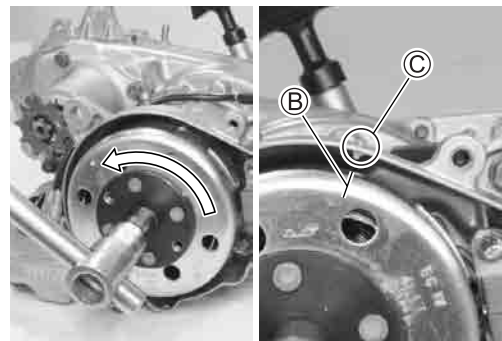

- Install the gasket ② and dowel pins ③.

**CAUTION**

The removed gasket must be replaced with a new one.

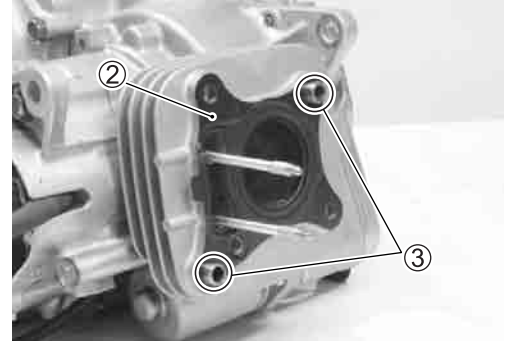

- Install the cylinder head.
- Position the push rods ① to the rocker arm adjust bolt hollows ④.

**CAUTION**

Install the push rods ① to the rocker arm adjust bolt hollows ④ and cam rocker arm hollows ⑤ surely.

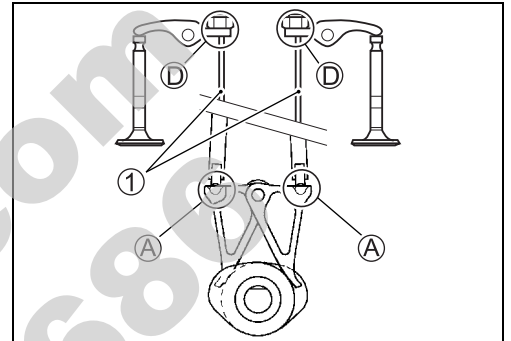

- Tighten the cylinder head bolts to the specified torque.

**Cylinder head bolt: 14 N·m (1.4 kgf·m, 10.0 lb·ft)**

**NOTE:**

Tighten the bolts little by little and diagonally.

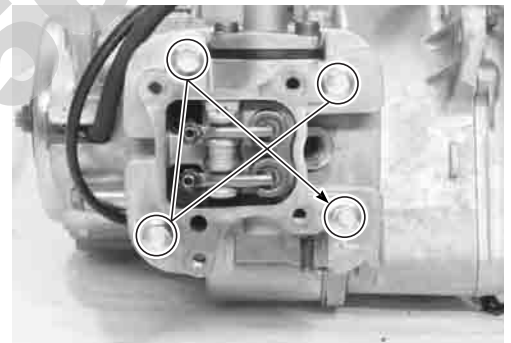

- Adjust the valve clearance ⑥. (☞ 2-5 to -6)

**DATA Valve clearance (when cold):**

(IN): 0.05 – 0.10 mm (0.002 – 0.004 in)

(EX): 0.10 – 0.15 mm (0.004 – 0.006 in)

**Valve clearance adjuster lock-nut ⑦:**

**7 N·m (0.7 kgf·m, 5.0 lb·ft)**

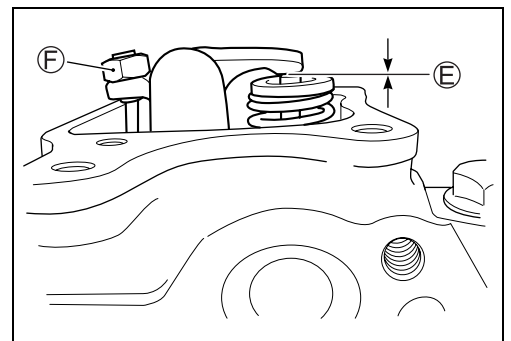
**GENERATOR COVER**

- Tighten the generator cover bolts to the specified torque.

**Generator cover bolt: 11 N·m (1.1 kgf·m, 8.0 lb·ft)**

**NOTE:**

Tighten the bolt ⑧ together with the washer and clamp ⑨.  
(☞ 7-15)

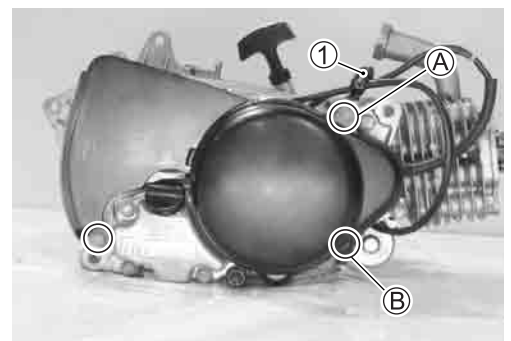

Ⓑ: Hooked part

### CYLINDER HEAD COVER

- Assemble the cylinder head cover gasket ①.

#### CAUTION

The removed gasket must be replaced with a new one.



- Tighten the cylinder head cover bolts to the specified torque.

 **Cylinder head cover bolt: 11 N·m (1.1 kgf·m, 8.0 lb·ft)**

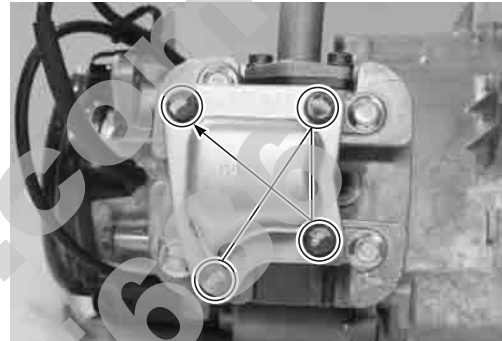

- Tighten the spark plug to the specified torque with a spark plug wrench.

 **Spark plug: 11 N·m (1.1 kgf·m, 8.0 lb·ft)**

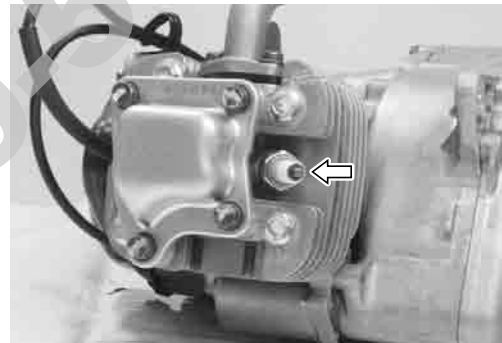

PartShark.com  
877-999-6666



# FUEL SYSTEM

## CONTENTS

<b>FUEL TANK AND FUEL VALVE</b> .....	4- 2
<b>REMOVAL</b> .....	4- 3
<b>FUEL FILTER INSPECTION AND CLEANING</b> .....	4- 3
<b>REMOUNTING</b> .....	4- 4
<b>CARBURETOR</b> .....	4- 5
<b>SPECIFICATIONS</b> .....	4- 6
<b>I.D. NO. LOCATION</b> .....	4- 6
<b>REMOVAL</b> .....	4- 7
<b>DISASSEMBLY</b> .....	4- 8
<b>CLEANING</b> .....	4-11
<b>INSPECTION AND ADJUSTMENT</b> .....	4-11
<b>REASSEMBLY AND REMOUNTING</b> .....	4-12

### **⚠ WARNING**

Gasoline must be handled carefully in an area well ventilated and away from fire or sparks.

# FUEL TANK AND FUEL VALVE

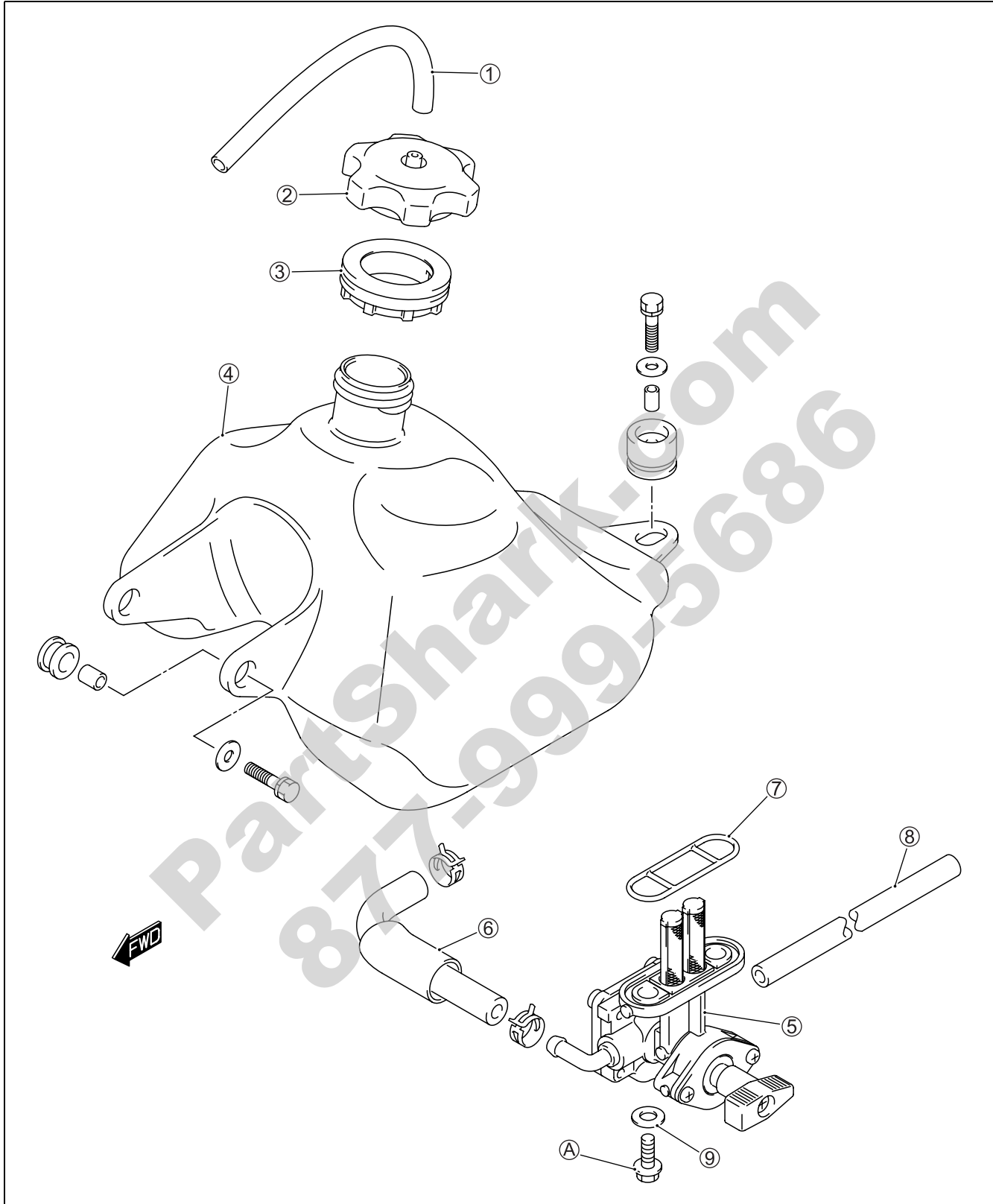

①	Fuel tank breather hose	⑥	Fuel hose
②	Fuel tank cap	⑦	O-ring
③	Fuel tank inlet rubber	⑧	Vacuum hose
④	Fuel tank	⑨	Gasket
⑤	Fuel valve	Ⓐ	Fuel valve bolt



ITEM	N-m	kgf-m	lb-ft
Ⓐ	4.5	0.45	3.3



## REMOVAL

### ⚠ WARNING

- \* Gasoline is highly flammable and explosive.
- \* Keep heat, spark and flame away.

- Remove the frame center cover. (👉 5-5)
- Turn the fuel valve to "ON" position.
- Disconnect the fuel hose ①.
- Disconnect the vacuum hose ②.

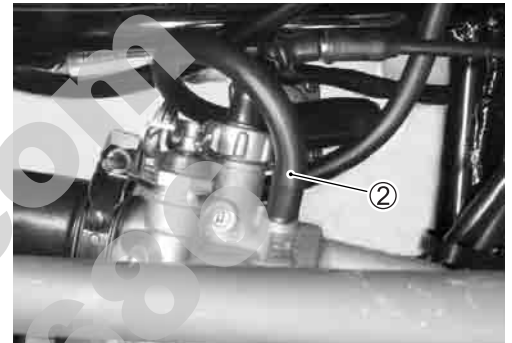

- Remove the fuel tank ③.

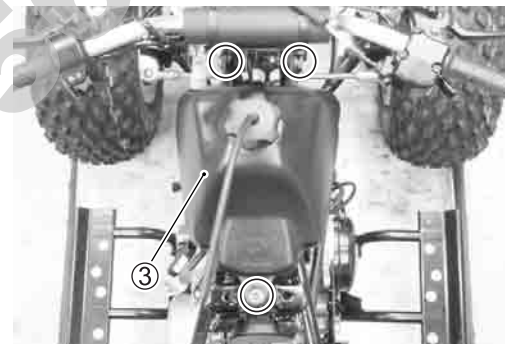

- Remove the fuel valve assembly ④.

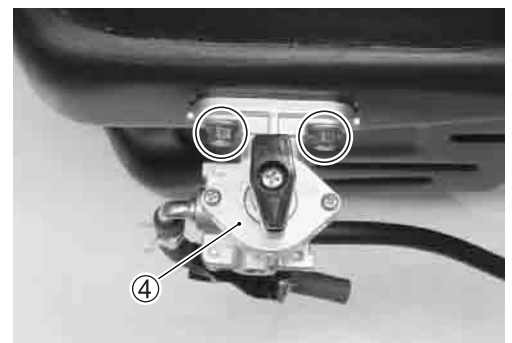

## FUEL FILTER INSPECTION AND CLEANING

If the fuel filter is dirty with sediment or rust, fuel will not flow smoothly and loss in engine power may result.

Clean the fuel filter with compressed air also check the fuel filter for cracks.

### ⚠ WARNING

- The gaskets and O-ring must be replaced with new ones to prevent fuel leakage.

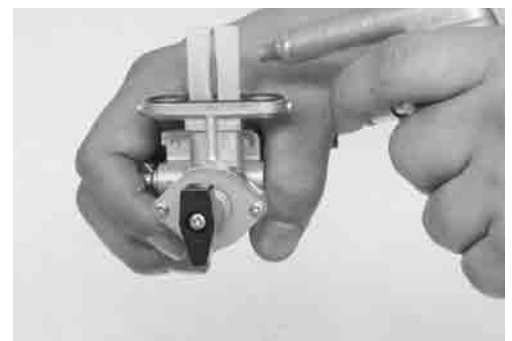

## REMOUNTING

Remount the fuel tank and fuel valve in the reverse order of removal. Pay attention to the following points:

- Tighten the fuel valve bolts to the specified torque.

 **Fuel valve bolt: 4.5 N-m (0.45 kgf-m, 3.3 lb-ft)**

### CAUTION



**The removed O-ring and gaskets must be replaced with new ones.**

#### NOTE:

Install the rounded side  of fuel hose to the fuel valve.

- Install the fuel tank.

#### NOTE:

Fuel tank breather hose  routing. ( 7-17)

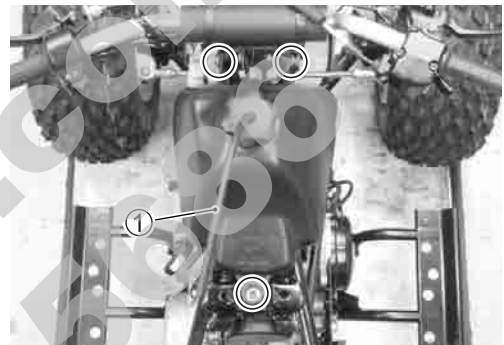
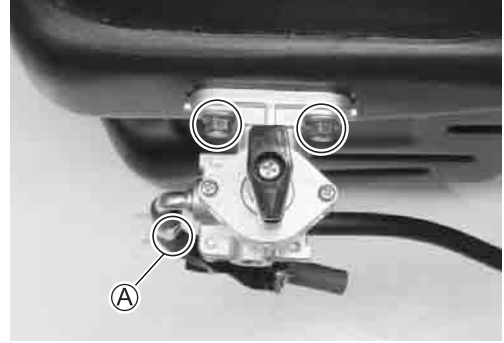

PartShark.com  
877-999-1600

# CARBURETOR

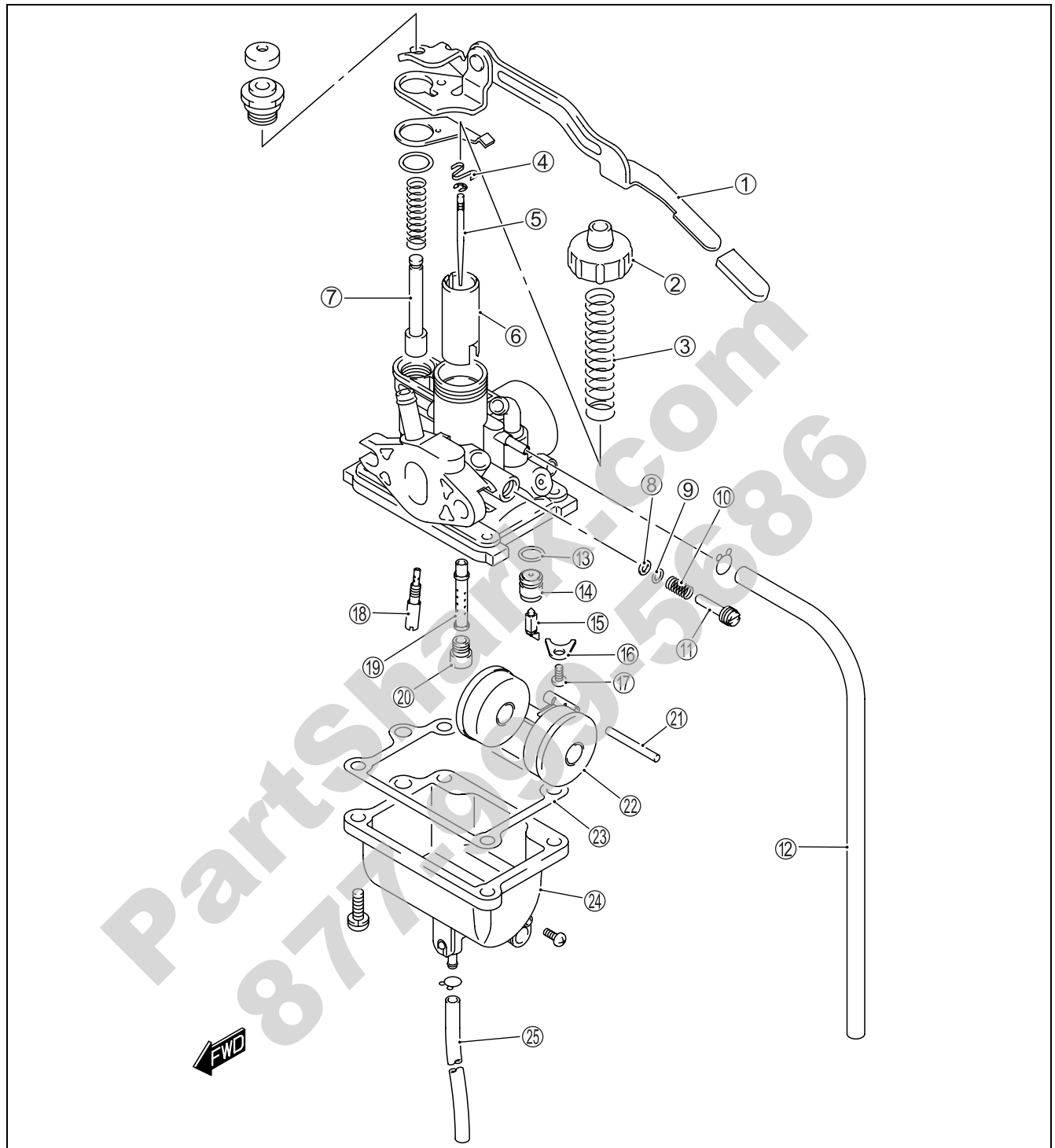

①	Choke lever	⑩	Spring	⑲	Needle jet
②	Carburetor top cap	⑪	Throttle stop screw	⑳	Main jet
③	Spring	⑫	Air vent hose	㉑	Float pin
④	Spring seat	⑬	O-ring	㉒	Float
⑤	Jet needle	⑭	Needle valve seat	㉓	Gasket
⑥	Piston valve	⑮	Needle valve	㉔	Float chamber
⑦	Starter plunger	⑯	Needle valve retainer	㉕	Drain hose
⑧	O-ring	⑰	Screw		
⑨	Washer	⑱	Pilot jet		

## SPECIFICATIONS

ITEM	SPECIFICATION
Carburetor type	MIKUNI VM13
Bore size	13 mm
I.D. No	43G0
Idle r/min.	2 000 ± 150 r/min.
Float height	23.4 ± 1.0 mm (0.92 ± 0.04 in)
Main jet (M.J.)	#58.8
Jet needle (J.N.)	3N39-1st
Needle jet (N.J.)	E-6
Pilot jet (P.J.)	#12.5
Air screw (A.S.)	PRE-SET
Throttle cable play	3 – 5 mm (0.12 – 0.20 in)

## I.D. NO. LOCATION

- The carburetor has I.D. Number (A) stamped on its body according to its specifications.

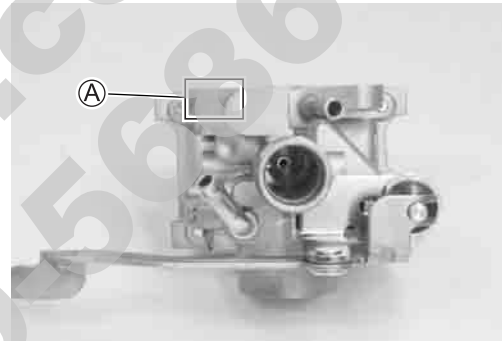

PartShark.com  
877-999-5686

## REMOVAL

- Remove the left frame cover. (☞ 5-4)
- Remove the right frame cover. (☞ 5-4)
- Remove the fuel hose ①.
- Remove the air vent hose ②.
- Remove the vacuum hose ③.

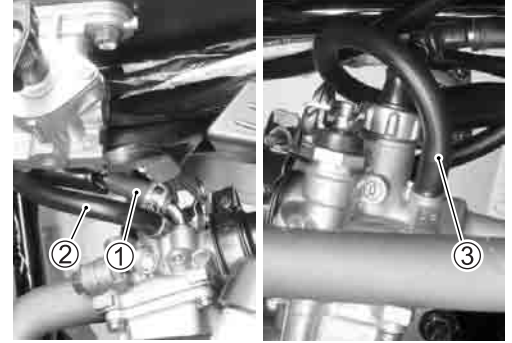

- Loosen the drain plug ④.
- Drain the fuel from the carburetor.
- Remove the drain hose ⑤ from the clamp.

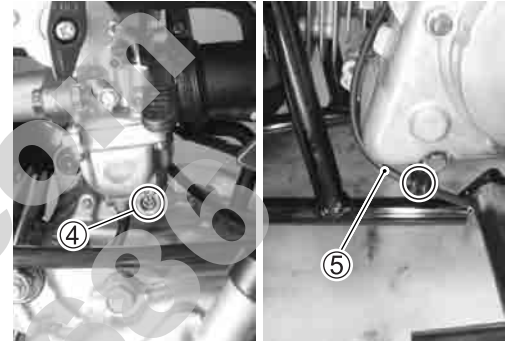

- Remove the carburetor top cap ⑥ with throttle cable and piston valve ⑦.

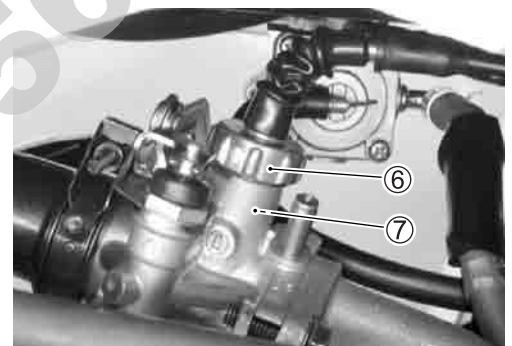

- Loosen the clamp bolt ⑧.

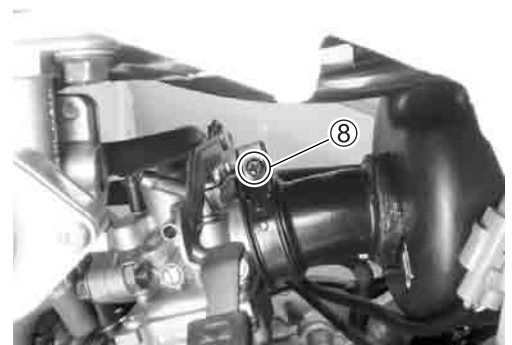

- Remove the carburetor mounting bolts/nuts ⑨.
- Remove the carburetor assembly ⑩.

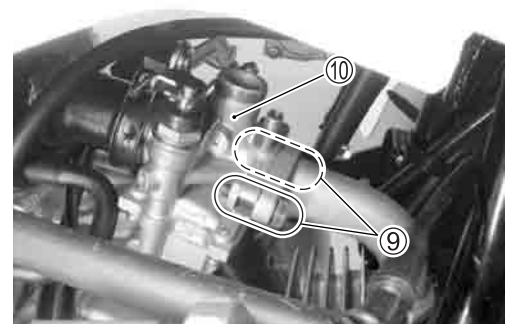

## DISASSEMBLY

### CAUTION

The removed O-rings and gasket must be replaced with new ones.

- Remove the spring ① and piston valve ② from the throttle cable.
- Remove the spring seat ③.
- Remove the jet needle ④ from the piston valve ②.
- Remove the drain hose ⑤.
- Remove the float chamber ⑥.

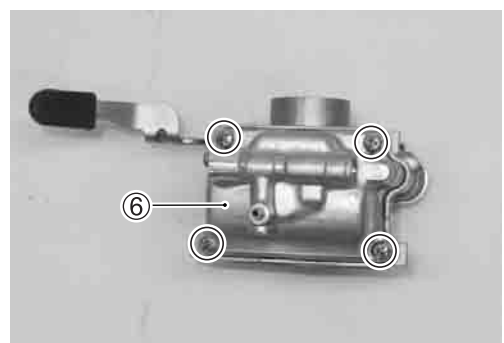
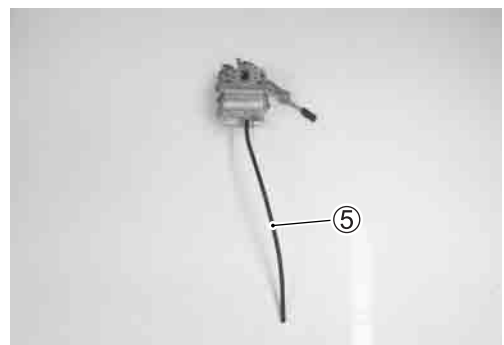
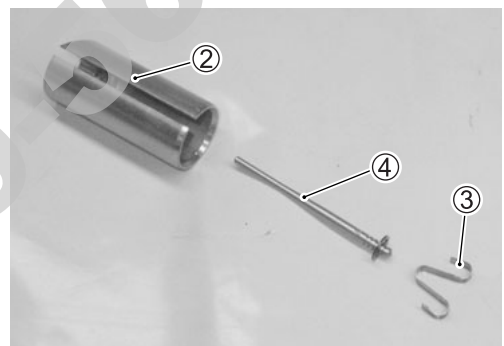
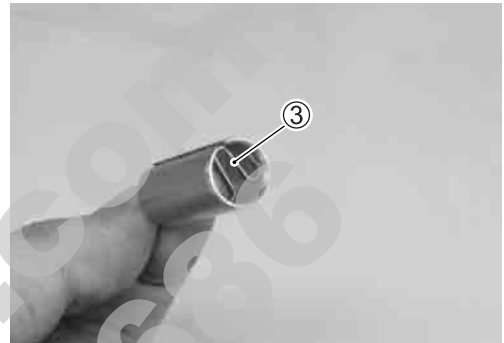
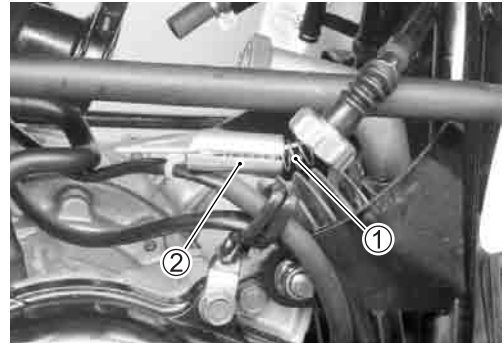

- Remove the gasket ⑦.

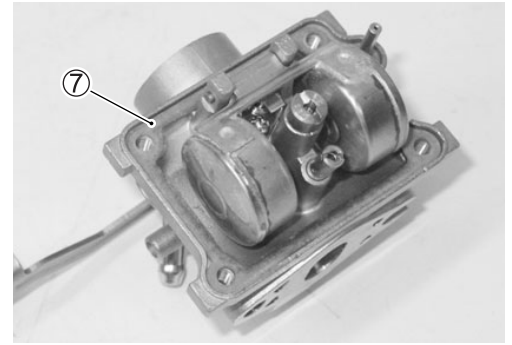

- Remove the float pin ⑧.
- Remove the float ⑨.
- Remove the needle valve ⑩.

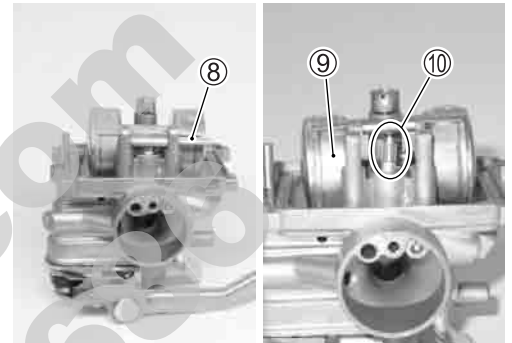

- Remove the main jet ⑪ and needle jet ⑫.
- Remove the pilot jet ⑬.
- Remove the screw ⑭.
- Remove the needle valve retainer ⑮ and needle valve seat ⑯.

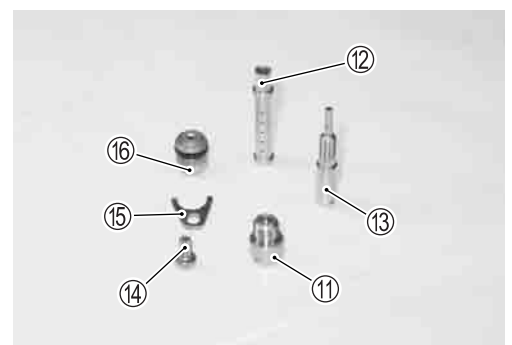
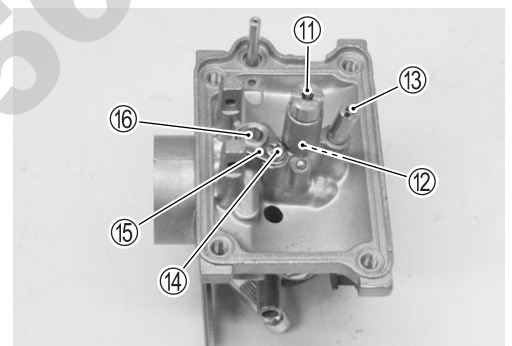

- Remove the throttle stop screw ⑰.

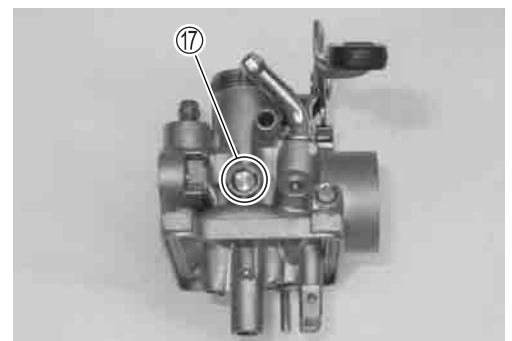

PartShark.com  
877-999-5629



- Remove the spring ⑱, washer ⑲ and O-ring ⑳.

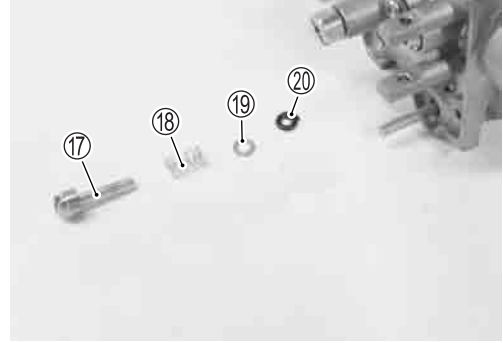

- Remove the choke lever ㉑.

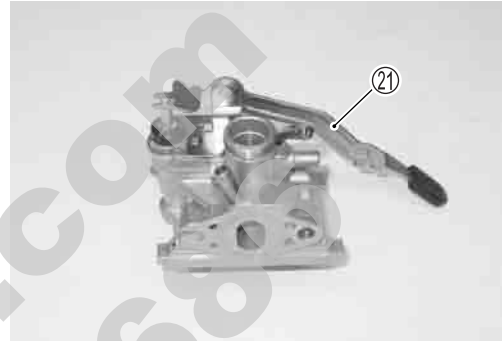

- Remove the starter plunger ㉒.

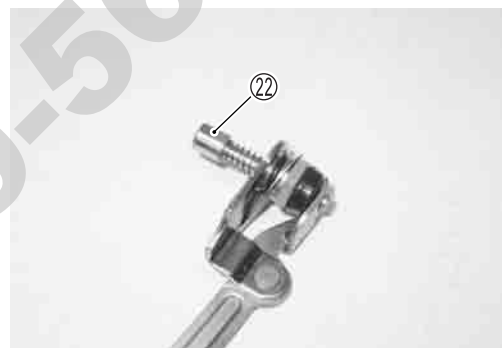

PartShark.com  
877-999-5688

## CLEANING

### ⚠ WARNING

Some carburetor cleaning chemicals, especially dip-type soaking solutions, are very corrosive and must be handled carefully. Always follow the chemical manufacturer's instructions on proper use, handling and storage.

- Clean all jets with a spray-type carburetor cleaner and dry them with compressed air.
- Clean all circuits of the carburetor thoroughly - not just the perceived problem area. Clean the circuits in the carburetor body with a spray-type cleaner and allow each circuit to soak, if necessary, to loosen dirt and varnish. Blow the body with compressed air.

### CAUTION

Do not use a wire to clean the jets or passageways. A wire can damage the jets and passageways. If the components cannot be cleaned with a spray-type cleaner, it may be necessary to use a dip-type cleaning solution and allow them to soak. Always follow the chemical manufacturer's instructions for proper use and cleaning of the carburetor components.

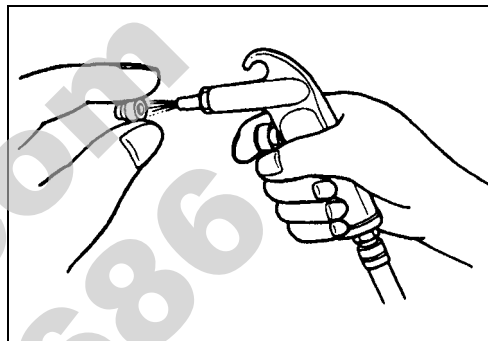

## INSPECTION AND ADJUSTMENT

- Check the following items for any damage or clogging.
 

* Pilot jet	* Starter passageway
* Main jet	* Needle jet
* Starter plunger	* Throttle stop screw
* Float	* Needle valve seat
* Piston valve	* Jet needle
* Pilot passageway	
- If any abnormal condition is found, clean the part. If damage or clogging is found, replace the part with a new one.

### NEEDLE VALVE INSPECTION

If foreign matter is caught between the valve seat and the needle valve, the gasoline will continue flowing and overflow. If the needle valve is worn beyond the permissible limit, similar trouble will occur. Conversely, if the needle valve sticks, the gasoline will not flow into the float chamber. Clean the float chamber and float parts with gasoline.



If the needle valve is worn, as shown in the illustration, replace the needle valve assembly with a new one. Clean the fuel passage of the mixing chamber with compressed air.

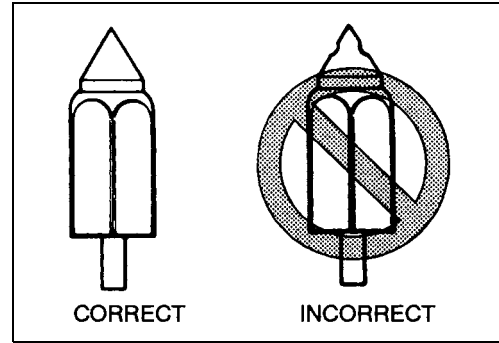

### FLOAT HEIGHT ADJUSTMENT

To check the float height, turn the carburetor upside down. Measure the float height (A) while the float arm is just contacting the needle valve with vernier calipers.

**DATA** Float height (A):  $23.4 \pm 1.0$  mm ( $0.92 \pm 0.04$  in)

**TOOL** 09900-20102: Vernier calipers

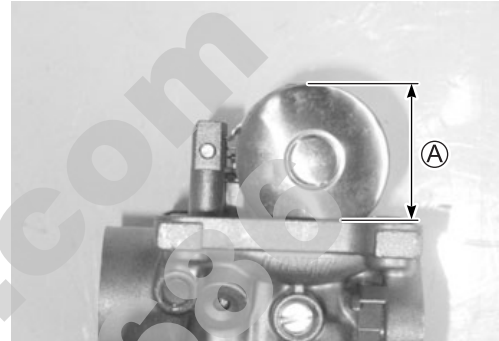

- If the float height (A) is out of specification, bend the float arm (1) to bring the float height (A) to the standard range.
- After adjusting, check the float height (A) again.

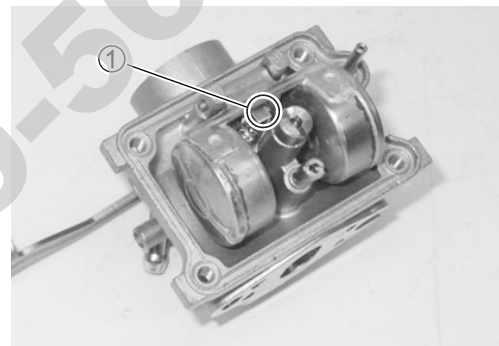

### REASSEMBLY AND REMOUNTING

Reassemble and remount the carburetor in the reverse order of removal and disassembly. Pay attention to the following points:

#### CAUTION

The O-rings and gasket must be replaced with new ones.

### AIR SCREW AND THROTTLE STOP SCREW

- Install the throttle stop screw (1).

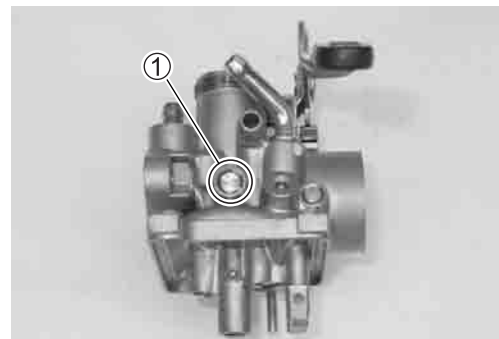

**GASKET**

- Install the gasket ①.

**CAUTION**

The gasket must be replaced with a new one.

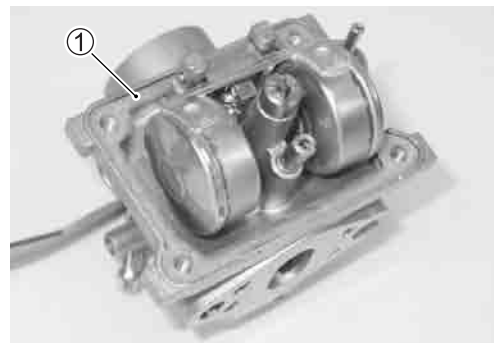

**PISTON VALVE AND SPRING**

- Install the piston valve ① and spring ② to the throttle cable.

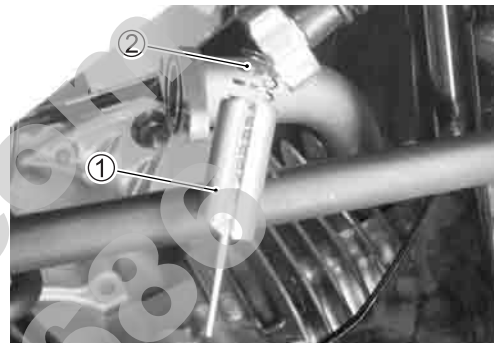

**CARBURETOR**

- Apply SUZUKI SUPER GREASE "A" to the O-ring ①.

99000-25010: SUZUKI SUPER GREASE "A" or equivalent

**CAUTION**

The O-ring must be replaced with a new one.

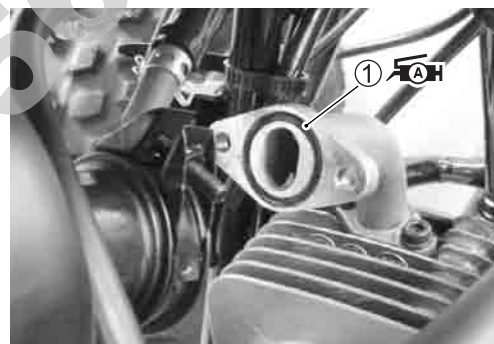

- Install the piston valve ② to the carburetor.

**CAUTION**

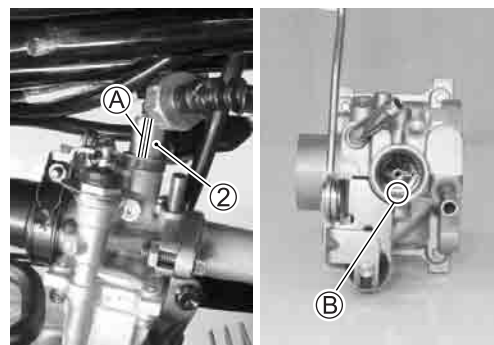

Align the slit **A** of the piston valve **②** with the projection **B** on the carburetor body.

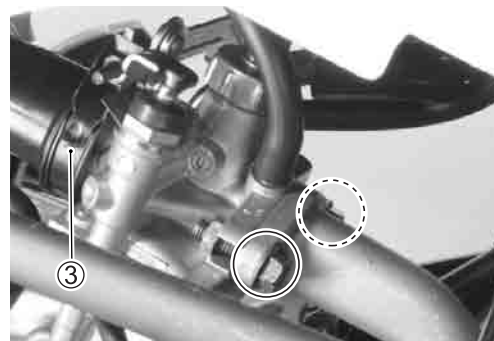

- Install the intake pipe clamp ③. (7-18)
- Tighten the carburetor mounting bolts to the specified torque.

Carburetor mounting bolt: 6 N·m (0.6 kgf-m, 4.5 lb-ft)



- After remounting the carburetor, perform the following:
  - \* Inspect fuel leakage.
  - \* Engine idle r/min adjustment.....  2-11
  - \* Throttle cable play adjustment .....  2-10

PartShark.com  
877-999-5686

# CHASSIS

## CONTENTS

<b>EXTERIOR PARTS</b> .....	5- 2
<b>CONSTRUCTION</b> .....	5- 2
<b>FASTENER REMOVAL AND INSTALLATION</b> .....	5- 3
<b>REMOVAL</b> .....	5- 4
<b>REMOUNTING</b> .....	5- 6
<b>FRONT AND REAR WHEELS</b> .....	5- 7
<b>CONSTRUCTION</b> .....	5- 7
<b>REMOVAL</b> .....	5- 7
<b>REMOUNTING</b> .....	5- 7
<b>TIRES</b> .....	5- 8
<b>TIRE REPLACEMENT</b> .....	5- 8
<b>FRONT BRAKE</b> .....	5-10
<b>CONSTRUCTION</b> .....	5-10
<b>REMOVAL</b> .....	5-11
<b>INSPECTION AND DISASSEMBLY</b> .....	5-12
<b>REASSEMBLY AND REMOUNTING</b> .....	5-14
<b>STEERING AND FRONT SUSPENSION</b> .....	5-16
<b>CONSTRUCTION</b> .....	5-16
<b>REMOVAL AND DISASSEMBLY</b> .....	5-18
<b>INSPECTION</b> .....	5-21
<b>REASSEMBLY AND REMOUNTING</b> .....	5-23
<b>TOE-IN ADJUSTMENT</b> .....	5-27
<b>REAR BRAKE AND REAR AXLE HOUSING</b> .....	5-28
<b>CONSTRUCTION</b> .....	5-28
<b>REMOVAL</b> .....	5-29
<b>INSPECTION AND DISASSEMBLY</b> .....	5-31
<b>REASSEMBLY AND REMOUNTING</b> .....	5-33
<b>REAR SUSPENSION</b> .....	5-38
<b>CONSTRUCTION</b> .....	5-38
<b>REMOVAL AND DISASSEMBLY</b> .....	5-39
<b>INSPECTION</b> .....	5-40
<b>REASSEMBLY AND REMOUNTING</b> .....	5-40

## EXTERIOR PARTS CONSTRUCTION

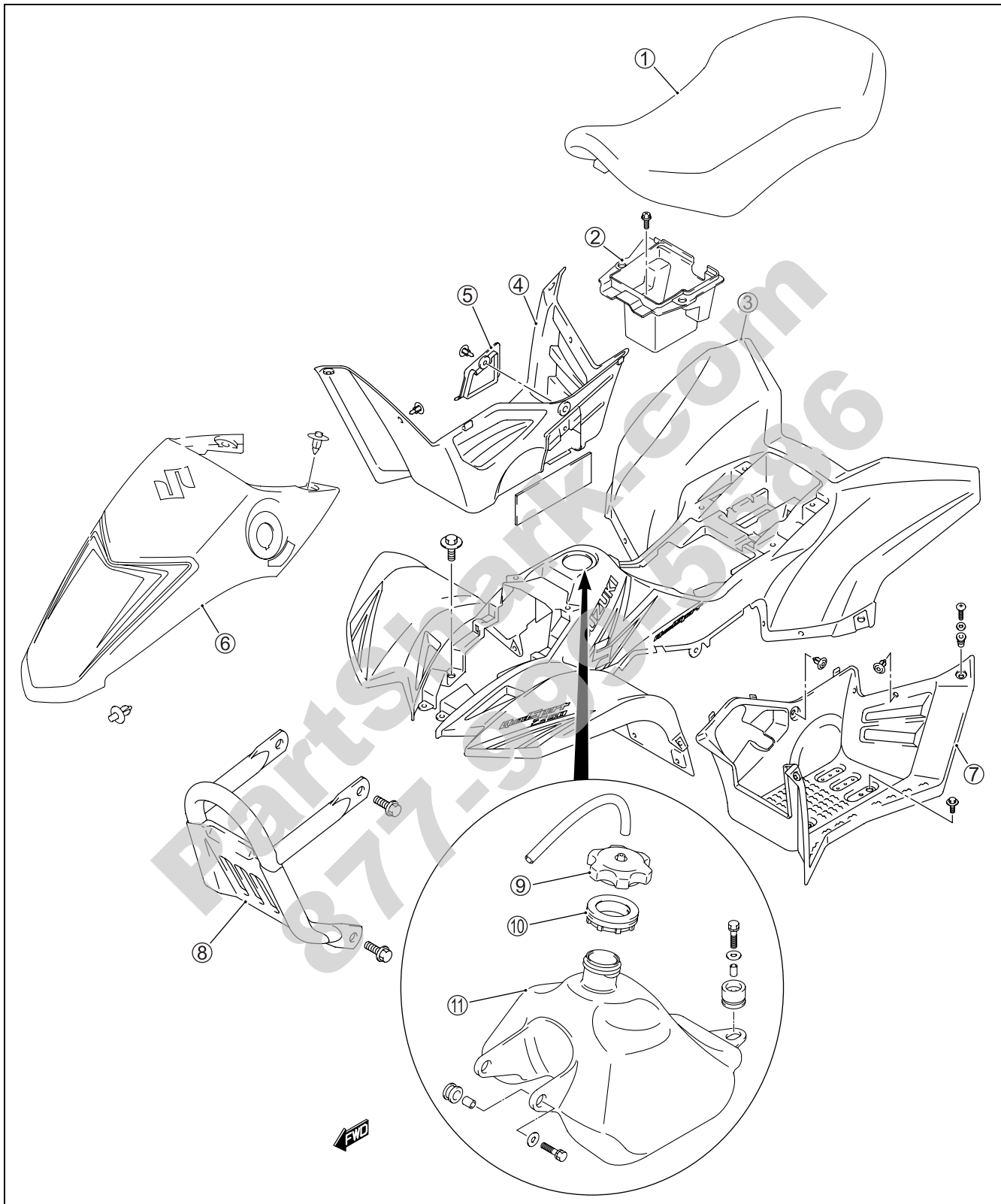

①	Seat	⑤	Maintenance lid	⑨	Fuel tank cap
②	Battery holder	⑥	Front frame cover	⑩	Fuel tank inlet rubber
③	Frame center cover	⑦	Left frame cover	⑪	Fuel tank
④	Right frame cover	⑧	Front grip		



## FASTENER REMOVAL AND INSTALLATION

### FASTENER

#### Removal

- Depress the head of fastener center piece ①.
- Pull out the fastener ②.

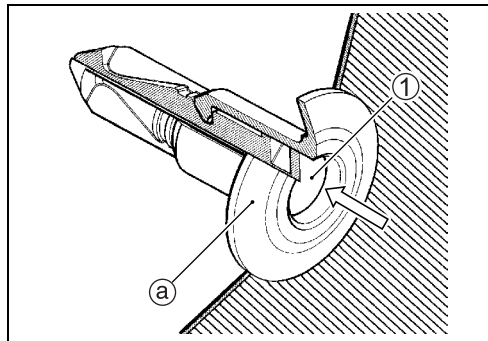

#### Installation

- Let the center piece stick out toward the head so that the pawls ② close.
- Insert the fastener into the installation hole.

#### NOTE:

To prevent the pawl ② from damage, insert the fastener all the way into the installation hole.

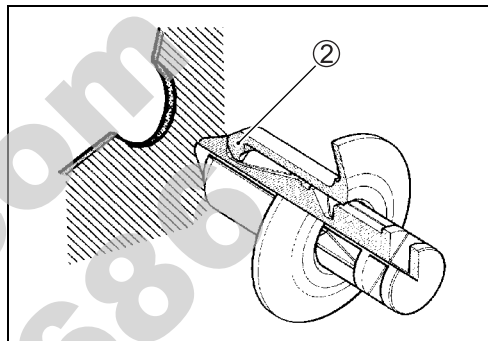

- Push in the head of center piece until it becomes flush with the fastener outside face.

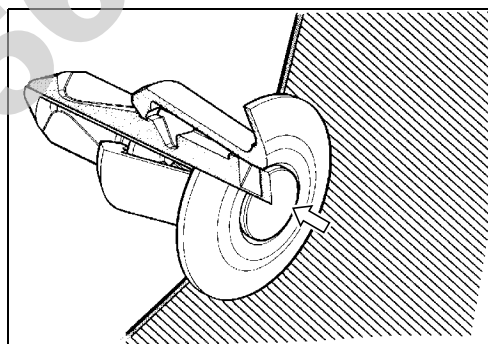

PartShark.com  
877-999-5680

## REMOVAL SEAT

- Remove the seat.



## FRONT FRAME COVER

- Remove the fasteners.
- Remove the ignition switch ring nut ①.
- Remove the front frame cover ②.

### NOTE:

“☆” indicates hook location.

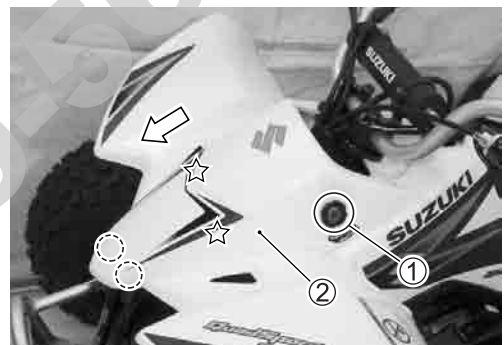

## LEFT FRAME COVER

- Remove the screws ① and fasteners.
- Remove the bolts ②.
- Remove the left frame cover ③.

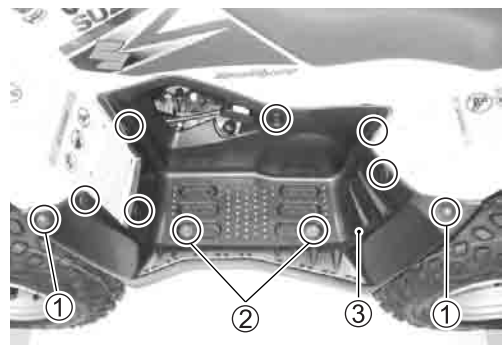

## RIGHT FRAME COVER

- Remove the screws ① and fasteners.
- Remove the bolts ②.
- Remove the right frame cover ③.

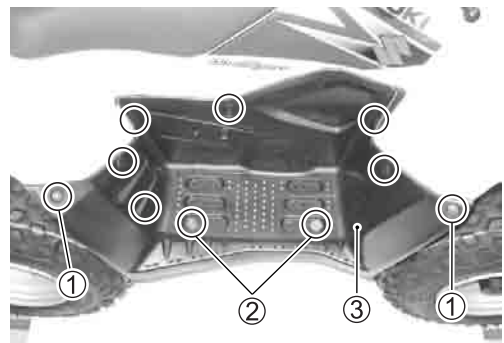

**FRAME CENTER COVER**

- Remove the seat. (☞ 5-4)
- Remove the front frame cover. (☞ 5-4)
- Remove the left frame cover. (☞ 5-4)
- Remove the right frame cover. (☞ 5-4)
- Disconnect the  $\ominus$  battery cable first, and then  $\oplus$  battery cable.
- Remove the battery ①.

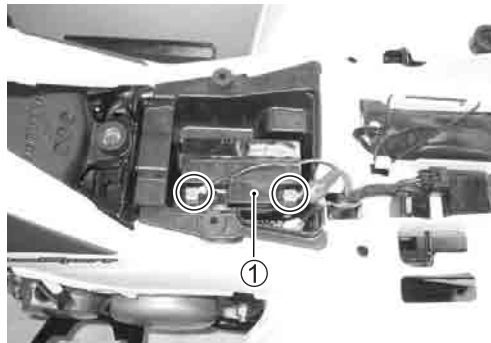

- Remove the fuse box ② from the battery holder ③.
- Remove the battery holder ③.

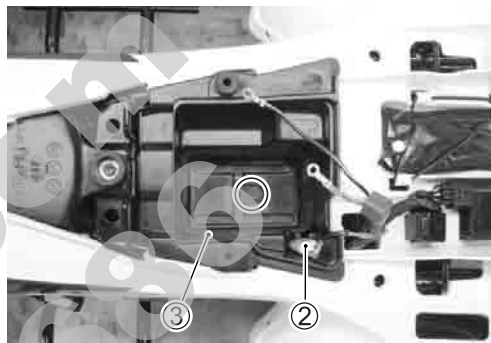

- Remove the starter relay ④ from the frame center cover ⑤.



- Disconnect the couplers.



- Remove the bolts.
- Remove the fuel tank cap ⑥.
- Remove the frame center cover ⑤.

**NOTE:**

Remount the fuel tank cap ⑥ after removing the frame center cover ⑤.

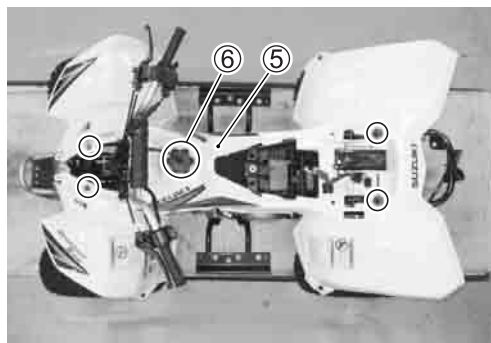

### MAINTENANCE LID

- Remove the fastener.
- Remove the maintenance lid ①.

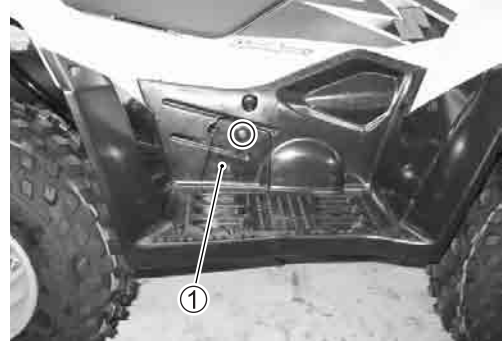

### FRONT GRIP

- Remove the front grip.



### REMountING

Remount the exterior parts in the reverse order of removal. Pay attention to the following points:

### FUEL TANK INLET RUBBER

- Align the fuel tank inlet rubber hollow (A) with the fuel tank lug (B).

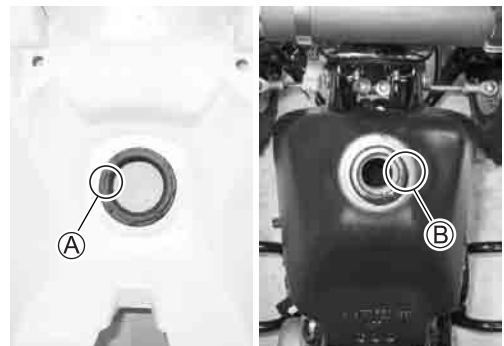

### NOTE:

Make sure that the "F" mark (C) on the fuel tank inlet rubber is forward.

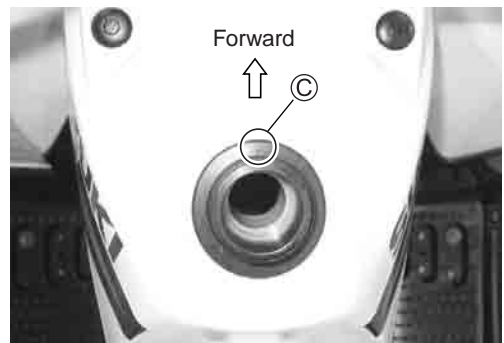

## FRONT AND REAR WHEELS CONSTRUCTION

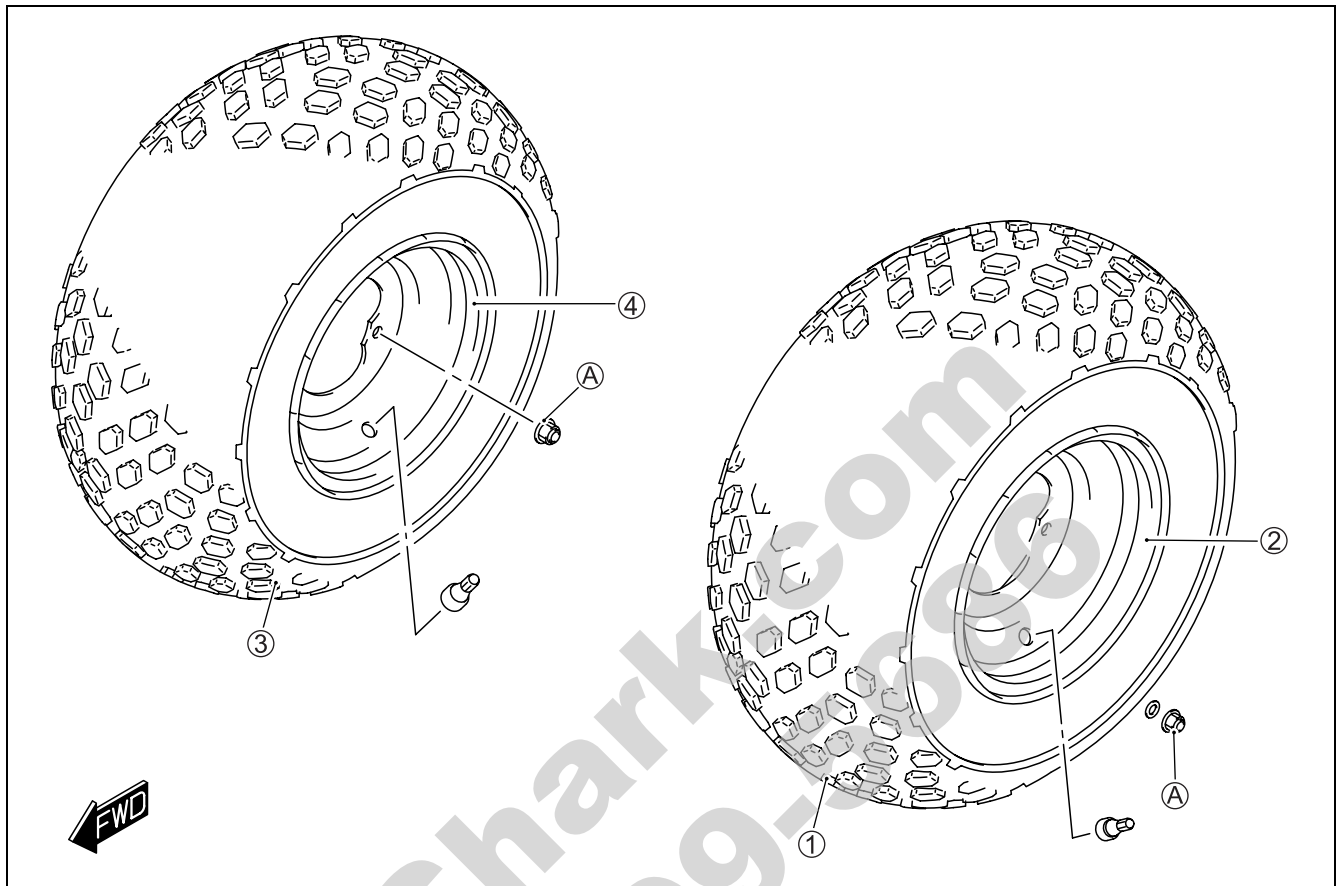

①	Front tire	④	Rear wheel
②	Front wheel	Ⓐ	Wheel set nut (front & rear)
③	Rear tire		



ITEM	N-m	kgf-m	lb-ft
Ⓐ	28	2.8	20.0

### REMOVAL

- Place the vehicle on level ground.
- Support the vehicle with a jack or wooden block and remove the front and rear wheel set nuts.
- Remove the front and rear wheels.



### REMOUNTING

Remount the wheels in the reverse order of removal. Pay attention to the following points:

- Installing each wheel, make sure the arrow Ⓐ on the tire points in the direction of rotation.
- Tighten the wheel set nuts to the specified torque.

 Front and rear wheel set nut: 28 N-m (2.8 kgf-m, 20.0 lb-ft)



## TIRES

### TIRE REPLACEMENT

- Remove the front and rear wheels. (☞ 5-8)
- After removing the air valve caps, release the tire pressure by depressing the valves.
- Dismount the bead from the rim completely as shown.

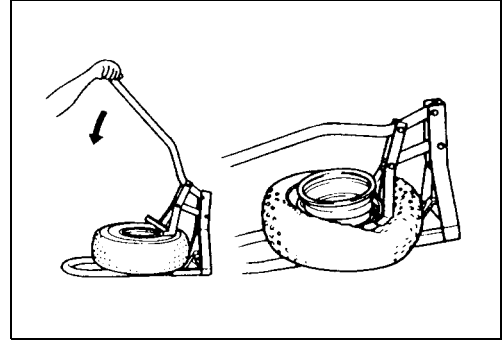

- Separate the tire from the rim using a set of tire levers and rim protectors.

#### CAUTION

When using the tire levers, do not scratch or hit the sealing portion (hump) of the wheel or it may cause air-leakage.

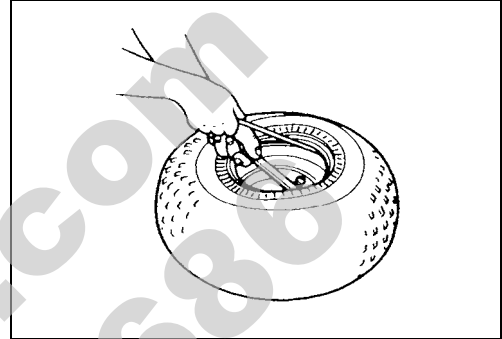

- Apply tire lubricant to the tire bead and the flange of the rim.

#### CAUTION

Never apply grease, oil, or gasoline to the tire bead because they will deteriorate the tire.

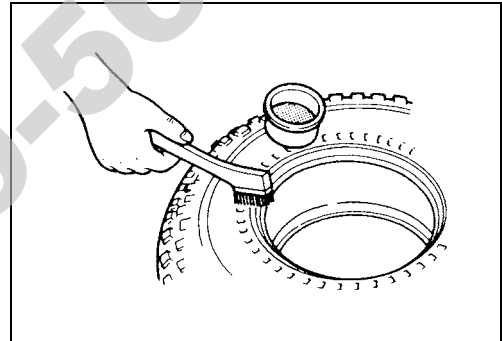

#### CAUTION

The standard tire fitted on this vehicle is AT16 × 8-7☆ for the front and rear.  
The use of tires other than the standard may cause instability. It is highly recommended to use the specified tire.

- Mount the tire on the rim by hand as shown.

#### NOTE:

Inspect the sealing portion of the rim before installing the tire on the rim.

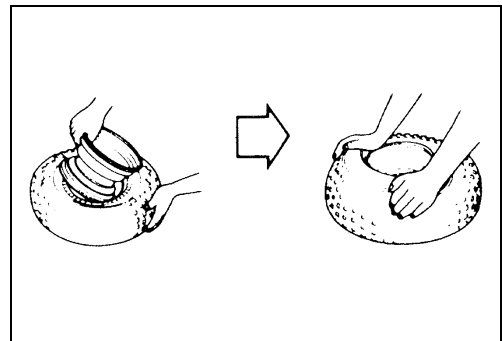



- When installing each tire, make sure the arrow **(A)** on the tire points in the direction of rotation. Also, make sure the outer side of the wheel rim is facing outward.

**NOTE:**

For inspecting the tires, refer to page 2-18.

Inspect the valve cores, before installing.

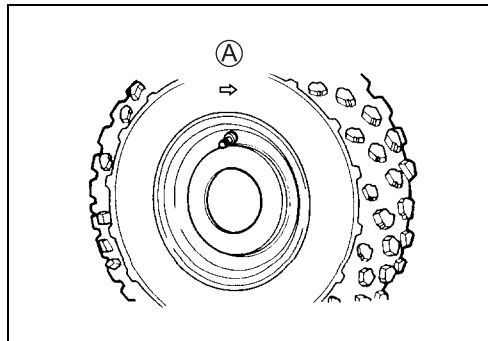

- Inflate the tire to seat the tire bead.

**DATA** Maximum tire bead seat pressure

Front : 250 kPa (2.5 kgf/cm<sup>2</sup>, 36 psi)

Rear : 250 kPa (2.5 kgf/cm<sup>2</sup>, 36 psi)

**CAUTION**

Place the tire under a protective tire cage or similar protective covering device before inflating the tire. To minimize the possibility of tire damage when seating the tire bead, never exceed the **MAXIMUM TIRE BEAD SEAT PRESSURE** rating shown on the tire.

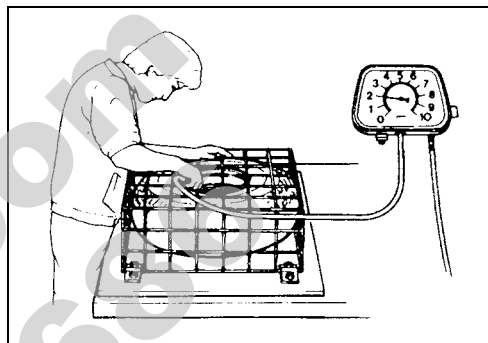
**NOTE:**

Check the "rim line" **(1)** cast on the tire sidewalls. It must be equidistant from the wheel rim all the way around. If the distance between the rim line and the wheel rim varies, this indicates that the bead is not properly seated. If this is so, deflate the tire completely and unseat the tire bead on both sides. Then, coat the bead with clean water and re-seat the tire.

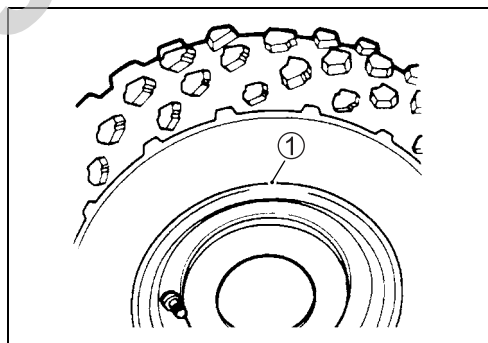

- Adjust the tire pressure to the specified pressure.

**DATA** Cold inflation tire pressure

Front : 20 kPa (0.20 kgf/cm<sup>2</sup>, 2.9 psi)

Rear : 20 kPa (0.20 kgf/cm<sup>2</sup>, 2.9 psi)

**DATA** Vehicle load capacity: 38 kg (84 lbs)**CAUTION**

Before inflating the tire, check the **MAXIMUM OPERATING PRESSURE** rating of the tire. This is indicated by a "☆" following the tire size shown on the sidewall. The number of "☆" on the tire indicates the maximum operating pressure.

**DATA** Maximum operating pressure

☆: 25 kPa (0.25 kgf/cm<sup>2</sup>, 3.6 psi)

☆☆: 35 kPa (0.35 kgf/cm<sup>2</sup>, 5.1 psi)

☆☆☆: 45 kPa (0.45 kgf/cm<sup>2</sup>, 6.5 psi)



# FRONT BRAKE CONSTRUCTION

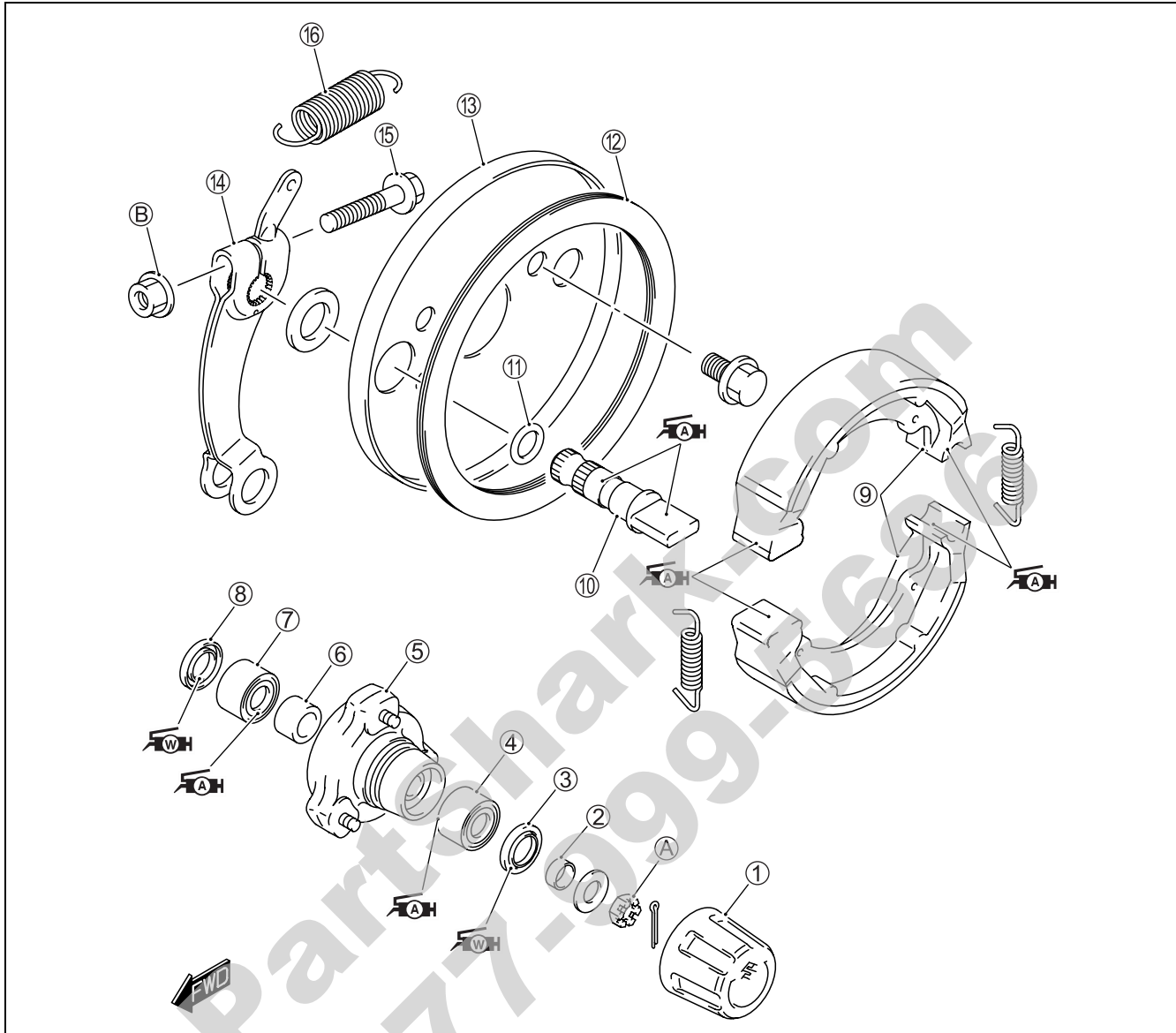

①	Wheel center cap	⑩	Front brake camshaft
②	Axle spacer	⑪	O-ring
③	Outer dust seal	⑫	Front brake dust seal
④	Wheel hub outer bearing	⑬	Brake plate
⑤	Front wheel hub	⑭	Brake cam lever
⑥	Spacer	⑮	Front brake cam lever bolt
⑦	Wheel hub inner bearing	⑯	Spring
⑧	Inner dust seal	(A)	Front hub nut
⑨	Front brake shoe	(B)	Front brake cam lever nut



ITEM	N·m	kgf·m	lb·ft
(A)	65	6.5	47.0
(B)	3.3	0.33	2.5

**REMOVAL**

- Remove the front wheel. (☞ 5-8)
- Remove the wheel center cap.
- Remove the cotter pin and front hub nut ①.

**CAUTION**

The removed cotter pin must be replaced with a new one.

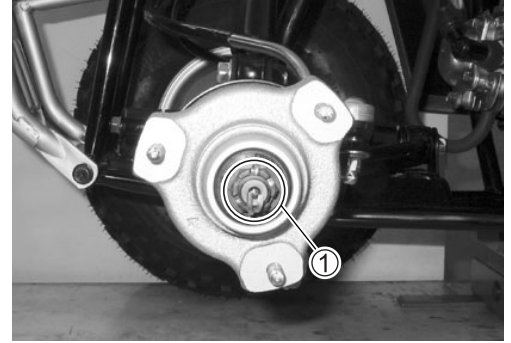

- Remove the front wheel hub ②.

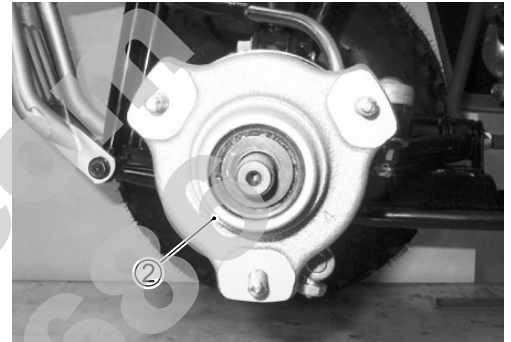

- Remove the front brake shoe assembly ③.

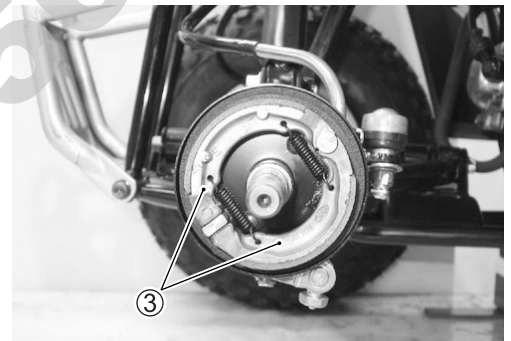

- Remove the spring ④.
- Remove the front brake adjusting nut ⑤.
- Remove the front brake cam lever nut ⑥ and bolt ⑦.

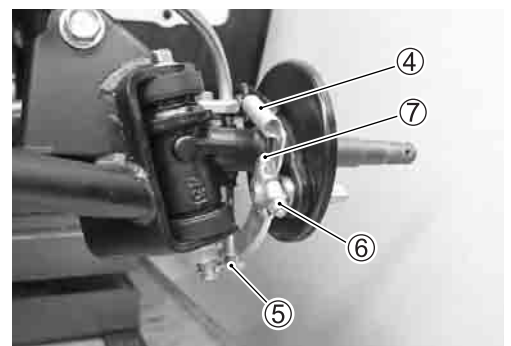

- Remove the brake cam lever ⑧ and front brake camshaft ⑨.

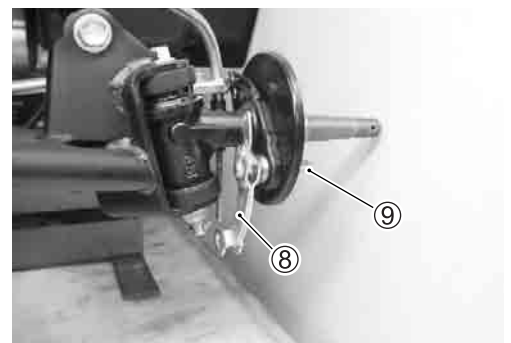

- Remove the brake plate ⑩.



- Remove the axle spacer ⑪.



## INSPECTION AND DISASSEMBLY BRAKE DRUM/WHEEL HUB

Inspect the brake drum and measure the brake drum I.D. to determine the extent of wear. Replace the brake drum if the measurement exceeds the service limit.

The value of this limit is indicated inside the brake drum.

**TOOL** 09900-20101: Vernier calipers

**DATA** Brake drum I.D.:

Service Limit: 80.7 mm (3.18 in)

### BRAKE SHOE

Inspect the brake shoes for wear or damage. If they are worn or damaged, replace it with new ones.

#### CAUTION

Replace the brake shoes as a set, otherwise braking performance will be adversely affected.

### FRONT BRAKE DUST SEAL

Inspect the front brake dust seal for wear or damage. If any defects are found, replace it with a new one.

#### NOTE:

Apply adhesive all around of the new dust seal, and attach it to the brake plate.

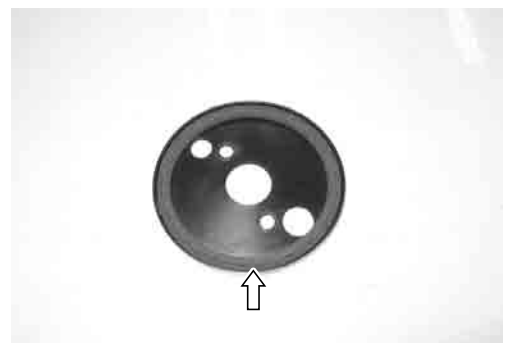

**DUST SEAL**

- Remove the each dust seal with the special tool.

**TOOL** 09913-50121: Oil seal remover

**CAUTION**

The removed dust seal must be replaced with a new one.

**BEARING**

Inspect the play (A) of the wheel hub bearings by finger while they are in the wheel hub. Rotate the inner race by finger to inspect it for abnormal noise and smooth rotation. If there is anything unusual, replace the bearing with a new one.

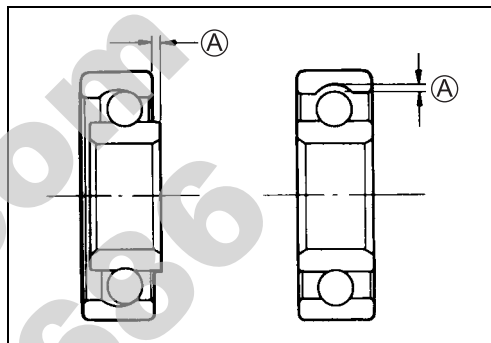

- Remove the wheel hub inner bearing with the special tool.

**TOOL** 09941-50111: Bearing remover

**CAUTION**

The removed bearing should be replaced with a new one.

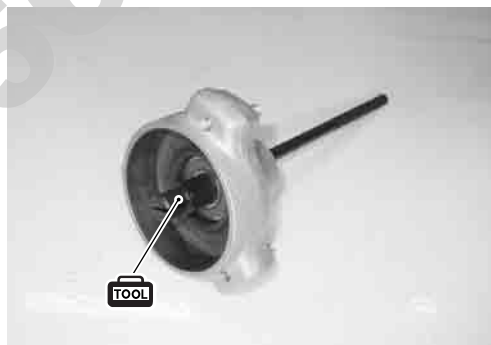

- Remove the spacer (1).

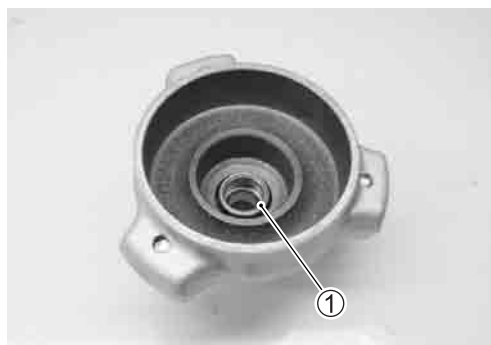

- Remove the wheel hub outer bearing with the special tool.

**TOOL** 09941-50111: Bearing remover

**CAUTION**

The removed bearing should be replaced with a new one.

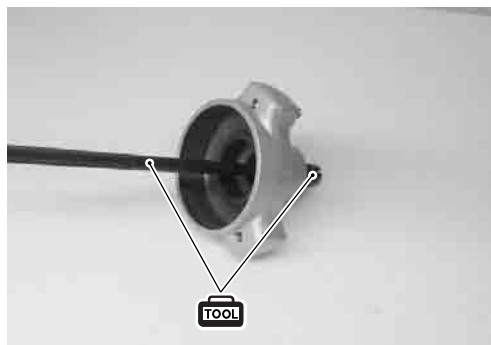

## REASSEMBLY AND REMOUNTING BEARING

- Apply SUZUKI SUPER GREASE “A” to the bearing before installing.

 **99000-25010: SUZUKI SUPER GREASE “A” or equivalent**

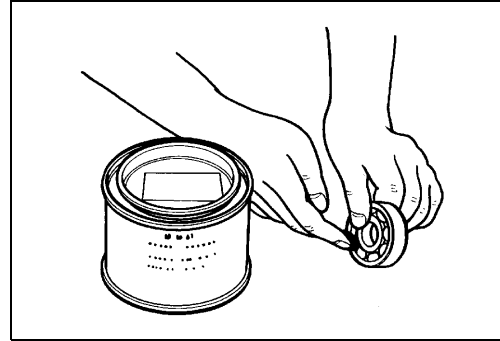

- Install the wheel hub inner bearing with the special tool.

 **09913-70210: Bearing installer set**

### CAUTION

- \* First install the wheel hub inner bearing, then install the spacer and outer bearing.
- \* The sealed cover of the bearing must face outside.



- Install the wheel hub outer bearing with the special tool.

 **09924-84521: Bearing installer set**

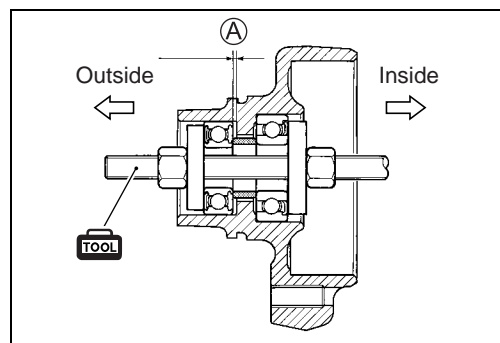

Ⓐ: Clearance

- Apply 3 grams of grease to the each dust seal lip before installing it.
- Install the dust seals with the special tool.

 **09913-70210: Bearing installer set**

 **99000-25161: WATER RESISTANCE GREASE or equivalent**

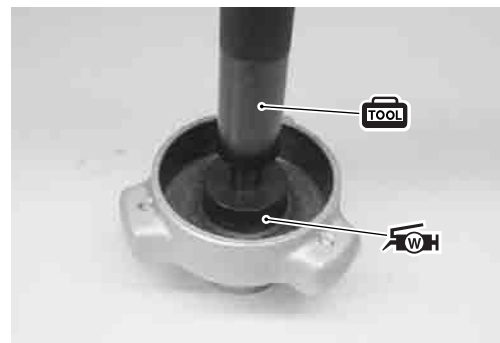

- Apply SUZUKI SUPER GREASE "A" to the camshaft.

 99000-25010: SUZUKI SUPER GREASE "A" or equivalent

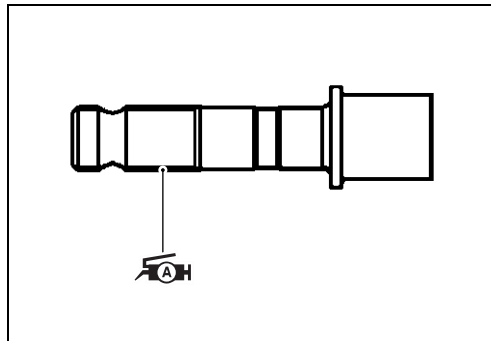

- Align the punched mark (A) of the brake cam lever with the slit (B) of the front brake camshaft.

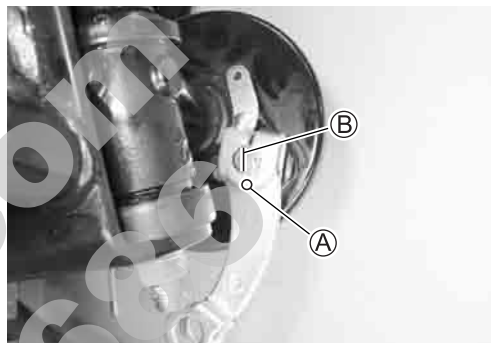

- Apply SUZUKI SUPER GREASE "A" to the front brake camshaft and pin, and install the brake shoes.

 99000-25010: SUZUKI SUPER GREASE "A" or equivalent

**⚠ WARNING**

Be careful not to apply too much grease to the cam and pin. If grease gets on the lining, brake slippage will result.

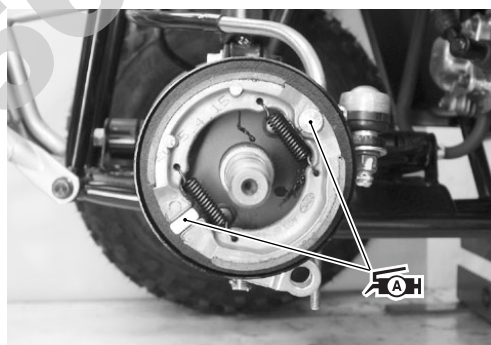

- Install the front wheel hub and spring.
- Tighten front brake cam lever nut to the specified torque.

 Front brake cam lever nut: 3.3 N·m (0.33 kgf·m, 2.5 lb-ft)



- Tighten the front hub nut (3) to the specified torque.

 Front hub nut: 65 N·m (6.5 kgf·m, 47.0 lb-ft)

- Install the new cotter pin to the nut.
- Install the front wheel. (📄 5-8)



- After installing the front brake, adjust the following item.  
Front brake lever play. (📄 2-17)



# STEERING AND FRONT SUSPENSION CONSTRUCTION

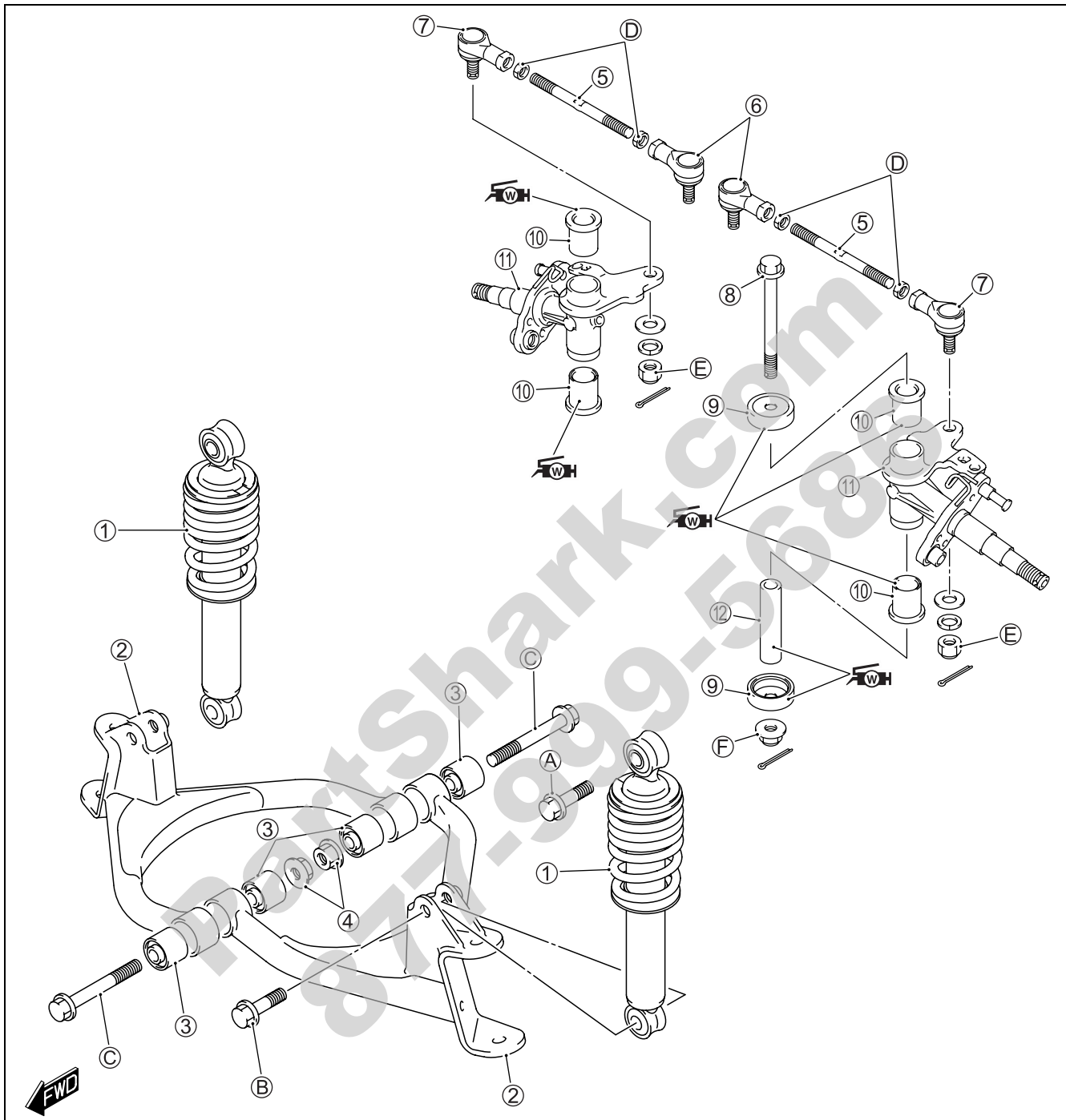

① Front shock absorber	⑩ Knuckle arm bushing
② Front suspension arm	⑪ Knuckle arm
③ Bushing	⑫ Spacer
④ Front suspension arm nut	Ⓐ Front shock absorber upper bolt
⑤ Tie-rod	Ⓑ Front shock absorber lower bolt
⑥ Inner tie-rod end	Ⓒ Front suspension arm bolt
⑦ Outer tie-rod end	Ⓓ Tie-rod locknut
⑧ Knuckle arm bolt	Ⓔ Tie-rod end nut
⑨ Dust seal	Ⓕ Knuckle arm nut



ITEM	N·m	kgf·m	lb·ft
Ⓐ	29	2.9	21.0
Ⓑ	29	2.9	21.0
Ⓒ	50	5.0	36.0
Ⓓ	29	2.9	21.0
Ⓔ	29	2.9	21.0
Ⓕ	50	5.0	36.0



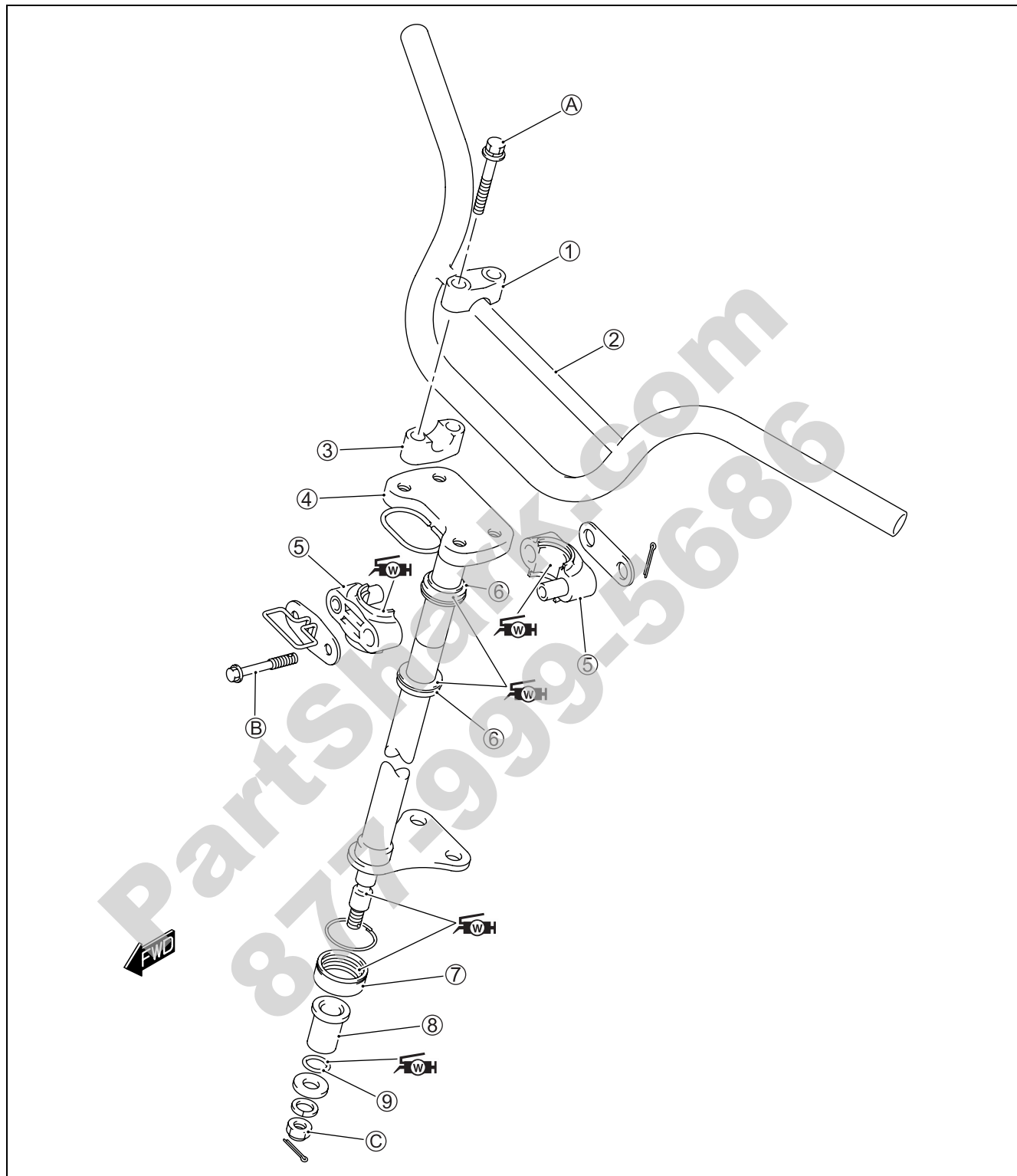

①	Handlebar upper holder	⑦	Steering shaft lower dust seal
②	Handlebars	⑧	Steering shaft bushing
③	Handlebar lower holder	⑨	O-ring
④	Steering shaft	(A)	Handlebar clamp bolt
⑤	Steering shaft holder	(B)	Steering shaft holder bolt
⑥	Dust seal	(C)	Steering shaft lower nut



ITEM	N·m	kgf·m	lb·ft
(A)	26	2.6	19.0
(B)	23	2.3	16.5
(C)	29	2.9	21.0

## REMOVAL AND DISASSEMBLY FRONT SUSPENSION

- Remove the front wheel. (☞ 5-8)
- Remove the front grip. (☞ 5-6)
- Remove the front brake. (☞ 5-12 to -13)
- Remove the front brake cable ①.

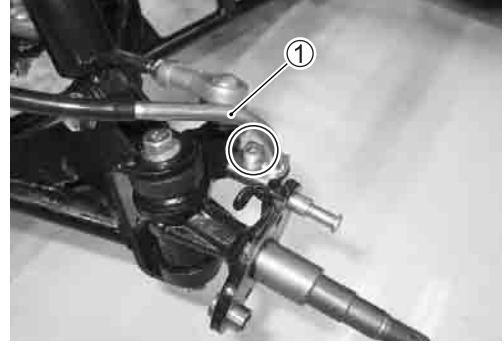

- Remove the cotter pin and knuckle arm nut ②.

### CAUTION

The removed cotter pin must be replaced with a new one.

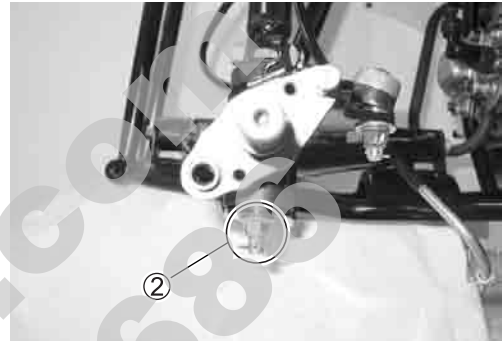

- Remove the cotter pin and tie-rod end nut ③.

### CAUTION

The removed cotter pin must be replaced with a new one.

- Remove the knuckle arm ④ and bolt ⑤.

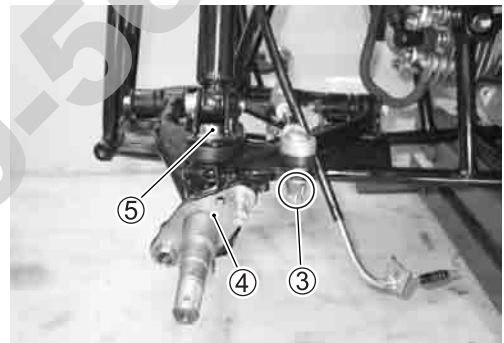

- Remove the front shock absorber ⑥.

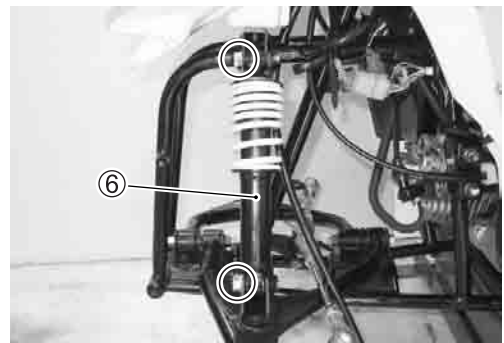

- Remove the front suspension arm ⑦.

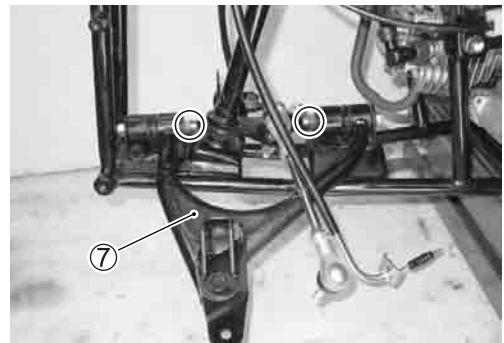

- Remove the dust seals and spacer.



- Remove the knuckle arm bushings with the special tools.

**TOOL** 09923-73210: Bearing remover  
09930-30104: Sliding shaft

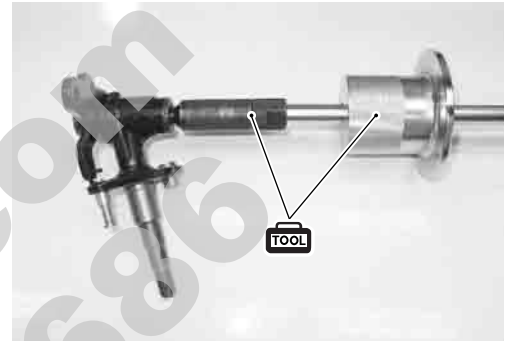

## STEERING

- Remove the front frame cover. (☞ 5-4)
- Remove the front suspension. (☞ 5-19)
- Remove the front and rear brake cables.

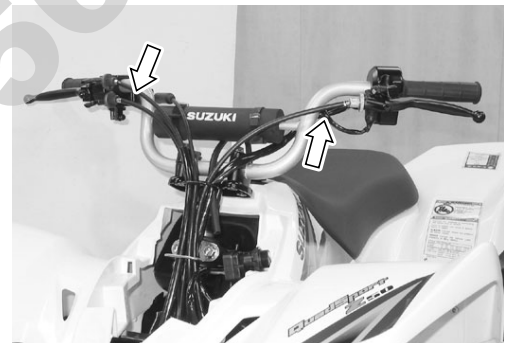

- Remove the throttle case cover screws.
- Remove the throttle cable.

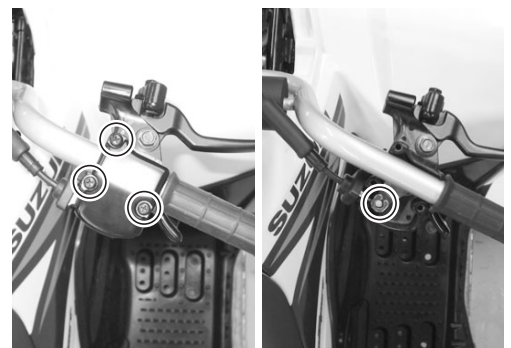

- Disconnect the ignition switch coupler.



- Remove the cotter pin and steering shaft lower nut ① and O-ring.
- Remove the cotter pins and tie-rod end nuts ②.

**CAUTION**

- \* The removed cotter pins must be replaced with new ones.
- \* The removed O-ring must be replaced with a new one.

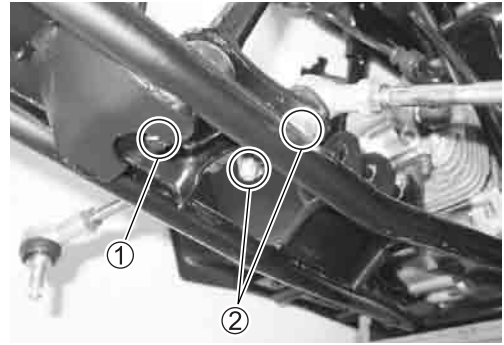

- Remove the tie-rods.
- Remove the handlebar clamp bolts.

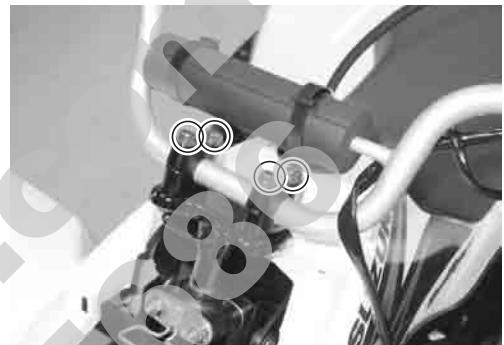

- Remove the cotter pins.

**CAUTION**

- The removed cotter pins must be replaced with new ones.

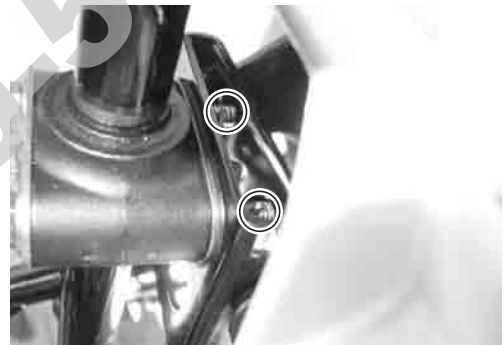

- Remove the steering shaft holder and steering shaft.



- Remove the steering shaft bushing.

**CAUTION**

The removed steering shaft bushing must be replaced with a new one.

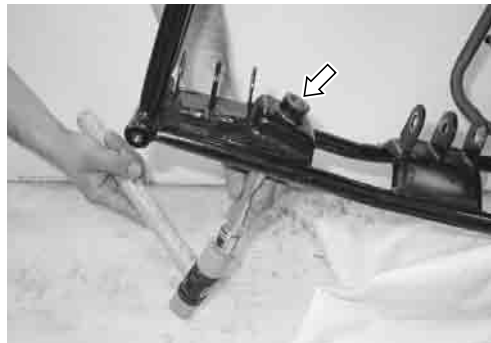

- Remove the dust seals ③ and steering shaft lower dust seal ④.

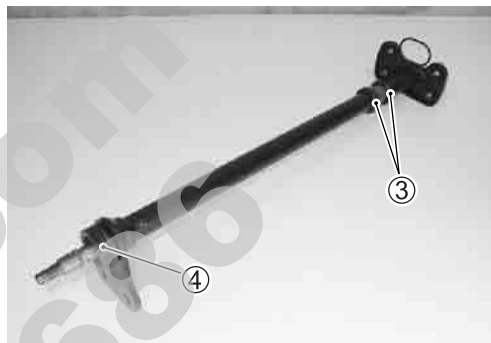

- Separate the tie-rod ends ⑤, locknuts (⑥, ⑦) and tie-rods ⑧.

**CAUTION**

The locknuts ⑥ have left-hand threads.

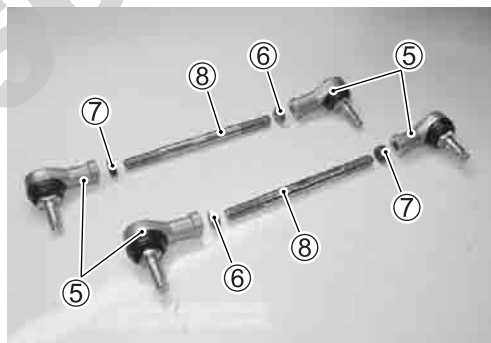
**INSPECTION**

Inspect the removed parts for the following abnormalities.

- \* Handlebar distortion.
- \* Handlebar clamp wear.

**DUST SEALS AND O-RING**

Inspect the dust seals and O-ring for wear or damage. If any defects are found, replace them with new ones.

**KNUCKLE ARM BUSHING**

Insert the spacer into the bushing and inspect for abnormal noise and smooth rotation while rotating the spacer. If any defects are found, replace it with a new one.



**SUSPENSION ARM**

Inspect the suspension arm and suspension arm bushing for wear or damage. If any defects are found, replace it with a new one.

**FRONT SHOCK ABSORBER**

Inspect the shock absorber body and bushing for damage and oil leakage. If any defects are found, replace it with a new one.

**CAUTION**

**Do not attempt to disassemble the front shock absorber. It is unserviceable.**

**TIE-ROD/TIE-ROD END**

Inspect the tie-rod for distortion and the boot for wear and tie-rod end for smooth movement. If any defects are found, replace it with a new one.

**STEERING SHAFT AND HOLDER**

Inspect the steering shaft for distortion or bends. If any defects are found, replace it with a new one.



Inspect the steering shaft holders for wear or damage. If any defects are found, replace them with new ones.



## REASSEMBLY AND REMOUNTING

Reassemble and remount the steering in the reverse order of removal and disassembly. Pay attention to the following points:

- Install the steering shaft bushing with the special tool.

 **09924-84521: Bearing installer set**



### STEERING SHAFT

- Apply grease to the steering shaft lower dust seal ①, steering shaft holders ②, dust seals ③, O-ring ④ and steering shaft ⑤ before remounting the steering shaft ⑤.

 **99000-25161: WATER RESISTANCE GREASE or equivalent**

- Install the steering shaft lower dust seal ①, steering shaft holders ②, dust seals ③ and O-ring ④ to the steering shaft ⑤.

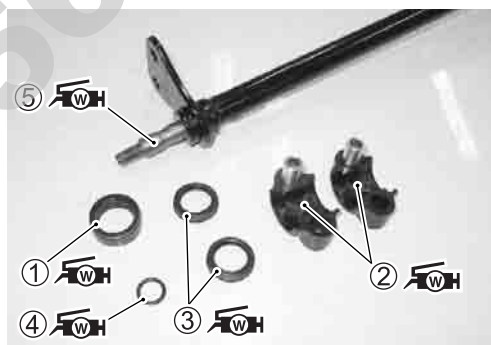

### CAUTION

To prevent the entry of dirt, the dust seal end (A) must face forward when installed on the steering shaft ⑤.

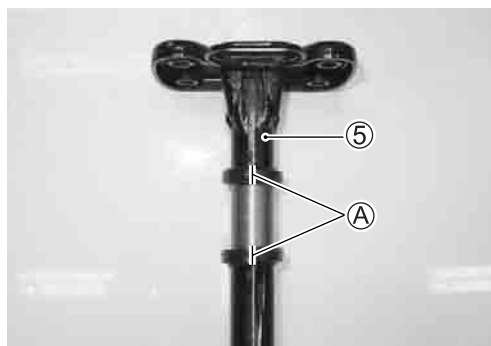

- Tighten the steering shaft lower nut to the specified torque and install the new cotter pin.

 **Steering shaft lower nut: 29 N·m (2.9 kgf·m, 21.0 lb-ft)**





- Tighten the steering shaft holder bolts to the specified torque and install the new cotter pins.

 **Steering shaft holder bolt: 23 N·m (2.3 kgf·m, 16.5 lb-ft)**

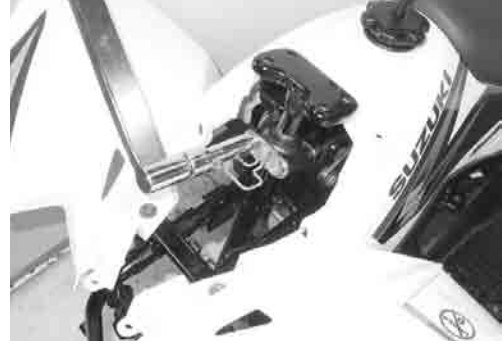

### TIE-ROD

- Tighten the tie-rod end nuts to the specified torque.

 **Tie-rod end nut: 29 N·m (2.9 kgf·m, 21.0 lb-ft)**

#### NOTE:

After installing the tie-rod end nuts, install the new cotter pins into the tie-rod ends.

- When installing the tie-rod end, make sure the punched mark "L" on the tie-rod ends come inside.



#### NOTE:

The locknuts ① have left-hand threads.

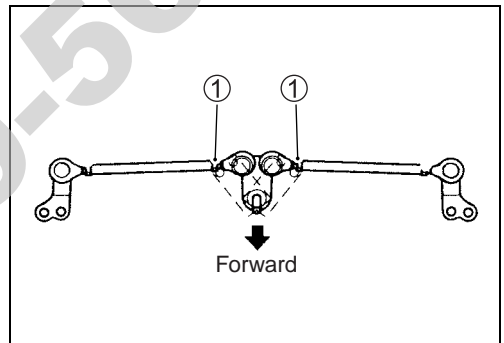

### HANDLEBAR

- Set the white mark on the handlebar lower holder to the forward.



- Align the punched mark on the handlebars with matching surface of the handlebar holders.



- Install the handlebar upper holders as shown.
- First, tighten the bolts ① to the specified torque and then tighten the bolts ② to the specified torque.

 **Handlebar clamp bolt: 26 N·m (2.6 kgf·m, 19.0 lb-ft)**

- Make sure the cable, harness are routing properly.

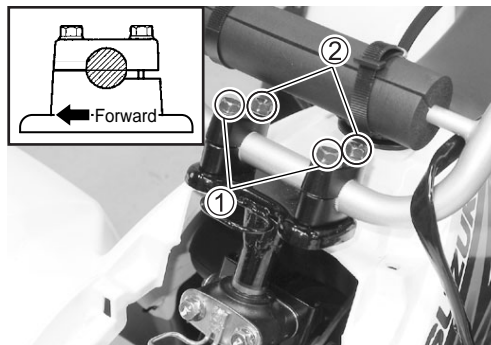

### HANDLEBAR SWITCH

- Align the handlebar switch lug ① with the handlebar hole ②.

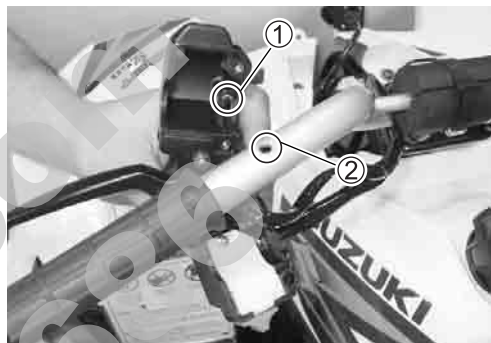

### THROTTLE LEVER CASE

- Align the throttle lever case lug ① with the handlebar hole ②.

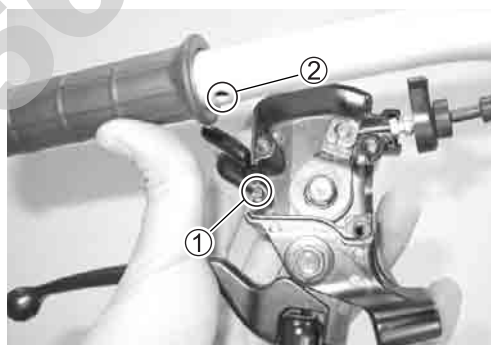

### FRONT SUSPENSION

- Install the knuckle arm bushing with the special tool.

 **09924-84510: Bearing installer set**

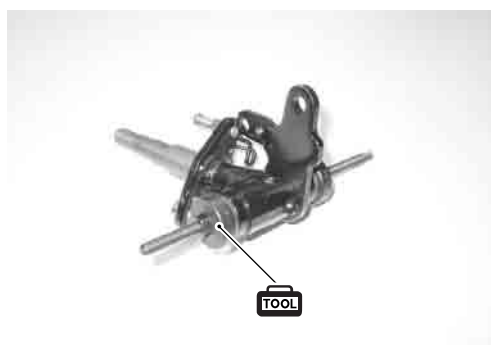

- Apply grease to the knuckle arm bushings, dust seals and spacer.
- Install the spacer and the dust seals.

 **99000-25161: WATER RESISTANCE GREASE or equivalent**

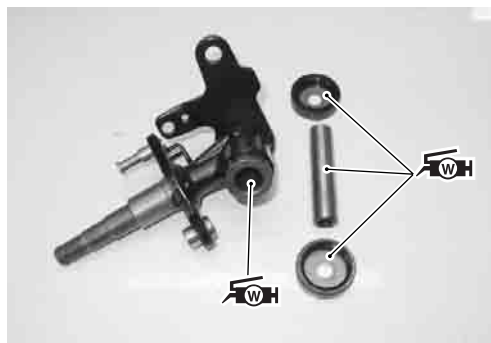

- Tighten the front suspension arm bolts to the specified torque.

 **Front suspension arm bolt: 50 N·m (5.0 kgf·m, 36.0 lb-ft)**



- Tighten the front shock absorber bolts to the specified torque.

 **Front shock absorber lower bolt: 29 N·m  
(2.9 kgf·m, 21.0 lb-ft)**

**Front shock absorber upper bolt: 29 N·m  
(2.9 kgf·m, 21.0 lb-ft)**



- Tighten the knuckle arm nut to the specified torque and install the new cotter pin.

 **Knuckle arm nut: 50 N·m (5.0 kgf·m, 36.0 lb-ft)**



- Tighten the tie-rod end nut to the specified torque and install the new cotter pin.

 **Tie-rod end nut: 29 N·m (2.9 kgf·m, 21.0 lb-ft)**

**NOTE:**

*Make sure that the steering turns smoothly in both directions.*

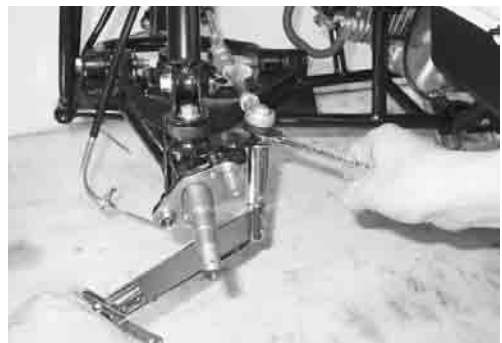

- Install the front brake. (☞ 5-16)
- Install the front grip. (☞ 5-6)
- Install the front wheel. (☞ 5-8)

After installing the front brake and front suspension, adjust the following items.

- \* Front brake lever play. (☞ 2-17)
- \* TOE-IN adjustment. (☞ 2-19)

## TOE-IN ADJUSTMENT

Adjust the toe-in as follows:

- Place the vehicle on level ground and set the handlebar straight.
- Make sure all the tires are inflated to the standard pressure. (☞ 2-18)
- Place 30 kg (66 lbs) weight on the seat.
- Loosen the locknuts (①, ②) on each tie-rod.

### CAUTION

The locknuts ② have left-hand threads.

- Measure the distance ① and ② of the front wheels, with a toe-in gauge as shown and calculate the difference between ① and ②.

### DATA Toe-in

Standard:  $1.5 \pm 3 \text{ mm}$  ( $0.06 \pm 0.12 \text{ in}$ )

- Temporarily tighten the four locknuts ③.
- Check that the distance ③ and ④ are equal, as shown. If the distances are not equal, adjust the tie-rod to the right or left until the toe-in is within specification. Check the toe-in again by measuring distance ① and ②.
- If the toe-in is not within specification, repeat the adjustment as above until the proper toe-in is obtained and distance ③ and ④ become equal.
- After adjustment has been made, tighten the four locknuts ③ to the specified torque.

 Tie-rod locknut: 29 N·m (2.9 kgf-m, 21.0 lb-ft)

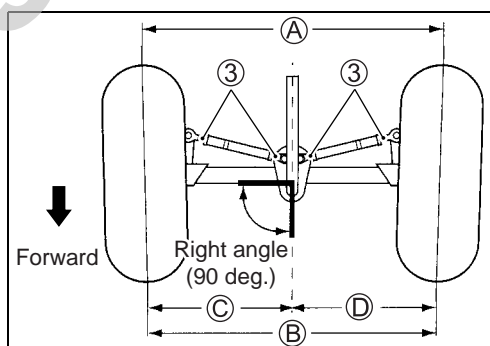
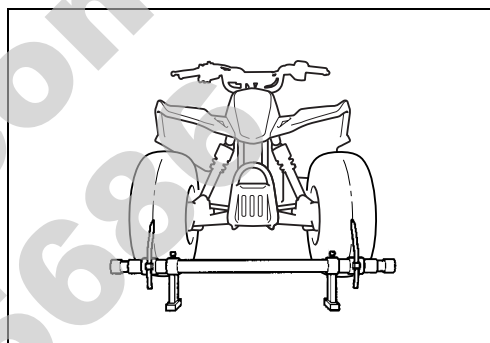
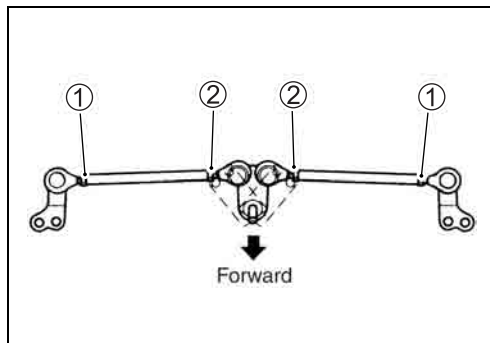

# REAR BRAKE AND REAR AXLE HOUSING CONSTRUCTION

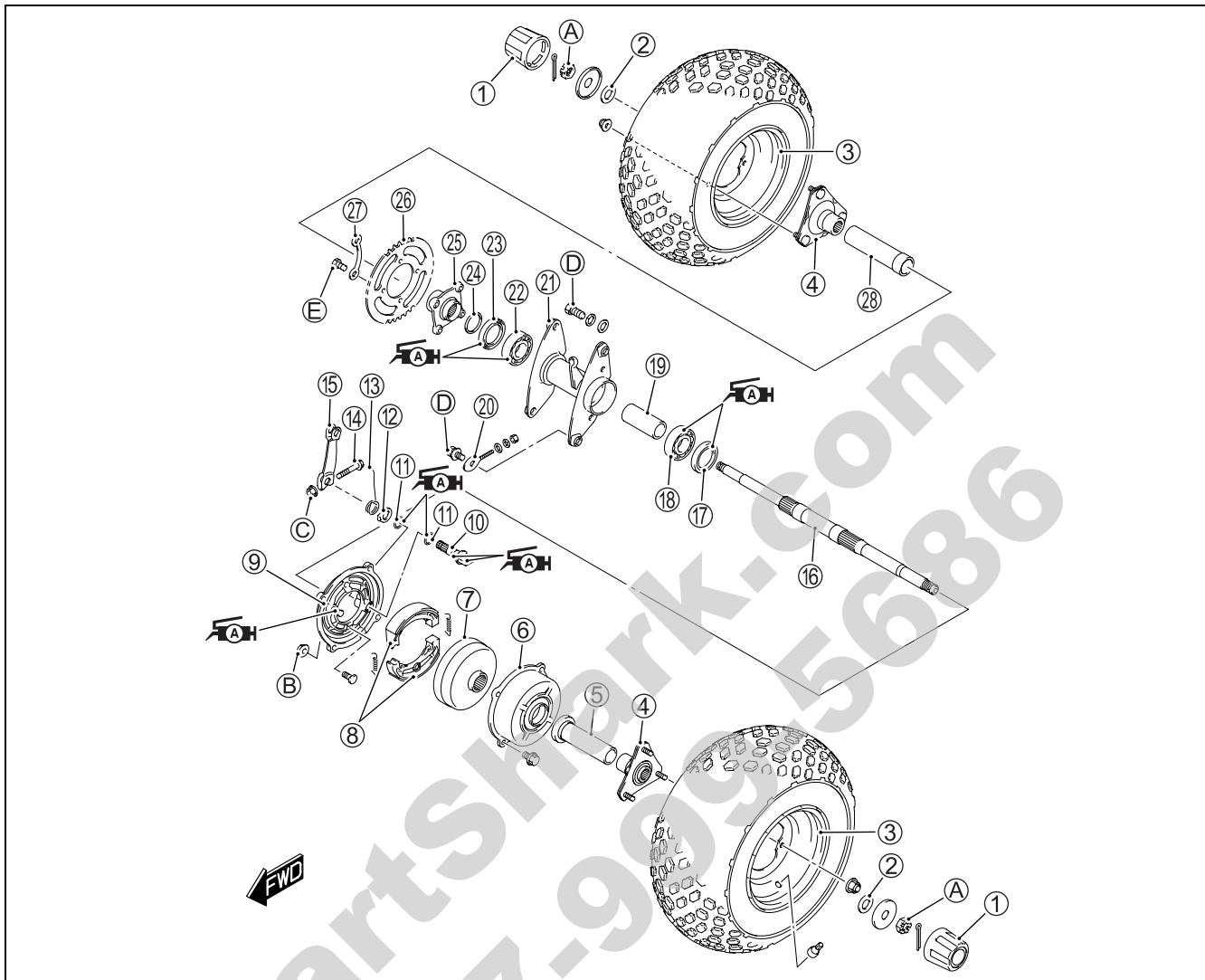

① Center cap	⑱ Rear axle housing bearing (L)
② Rear axle washer	⑲ Spacer
③ Rear wheel	⑳ Chain adjuster
④ Rear wheel hub	㉑ Rear axle housing
⑤ Spacer (L)	㉒ Rear axle housing bearing (R)
⑥ Rear brake drum cover	㉓ Dust seal (R)
⑦ Rear brake drum	㉔ Stopper ring
⑧ Rear brake shoe	㉕ Rear sprocket mounting flange
⑨ Rear brake panel	㉖ Rear sprocket
⑩ Rear brake camshaft	㉗ Rear sprocket washer
⑪ O-ring	㉘ Spacer (R)
⑫ Brake lining indicator plate	Ⓐ Rear hub nut
⑬ Spring	Ⓑ Rear brake panel nut
⑭ Rear brake cam lever bolt	Ⓒ Rear brake cam lever nut
⑮ Rear brake cam lever	Ⓓ Rear axle housing bolt
⑯ Rear axle	Ⓔ Rear sprocket bolt
⑰ Dust seal (L)	



ITEM	N-m	kgf-m	lb-ft
Ⓐ	75	7.5	54.0
Ⓑ	28	2.8	20.0
Ⓒ	7.7	0.77	5.5
Ⓓ	50	5.0	36.0
Ⓔ	23	2.3	16.5



**REMOVAL**

- Remove the cotter pin ①.

**CAUTION**

The removed cotter pin must be replaced with a new one.

- Remove the rear hub nut by applying the rear brake.
- Remove the rear wheels.
- Remove the center cap holder ②, rear axle washer ③ and rear wheel hub ④.

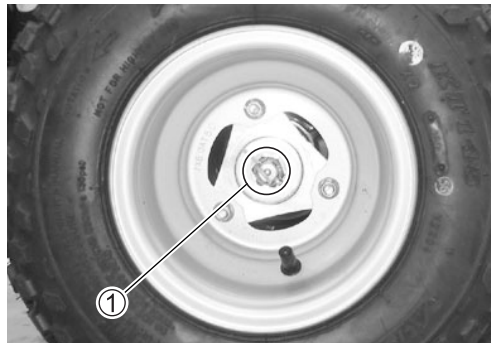

- Remove the spacers left ⑤ and right ⑥.

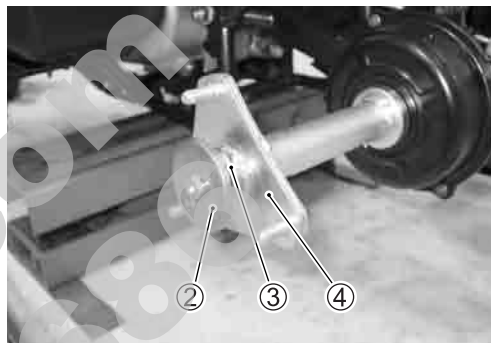

- Remove the chain case cover.

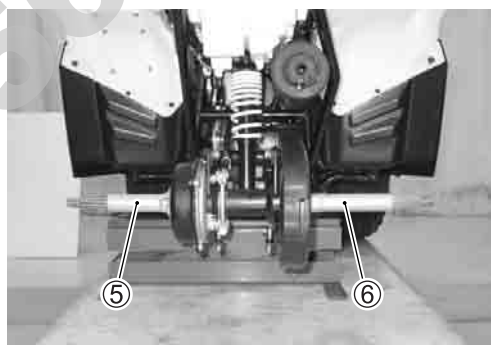

- Loosen the drive chain. (☞ 2-14)
- Remove the rear sprocket.

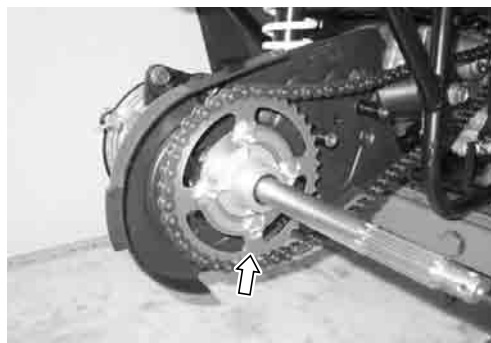

- Remove the rear brake drum cover.

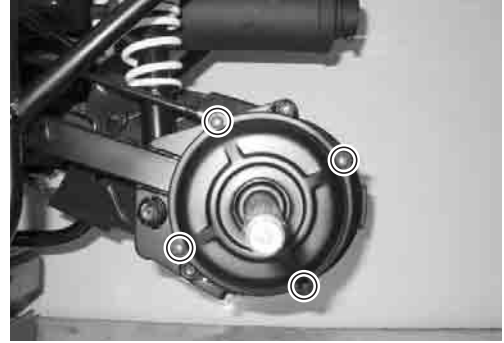

- Remove the rear axle.

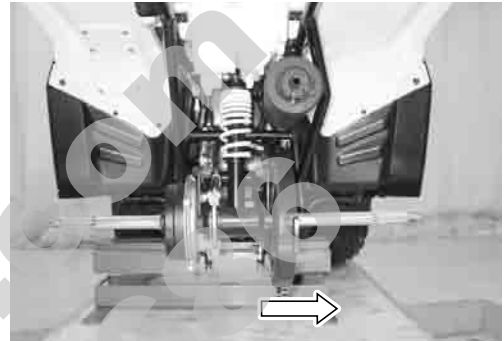

- Remove the rear brake drum.

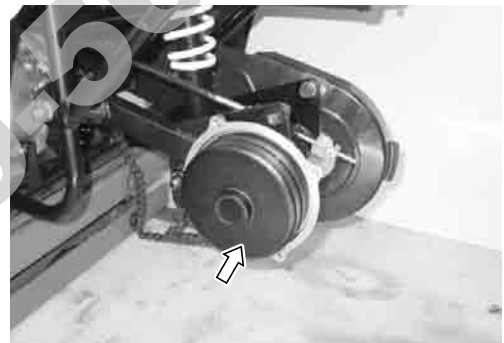

- Remove the rear brake shoes ⑦.

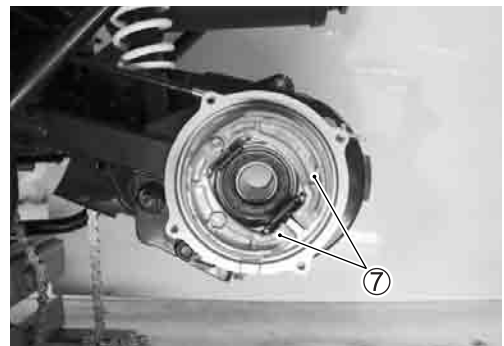

- Disconnect the rear brake cable ⑧.
- Remove the rear brake panel ⑨.

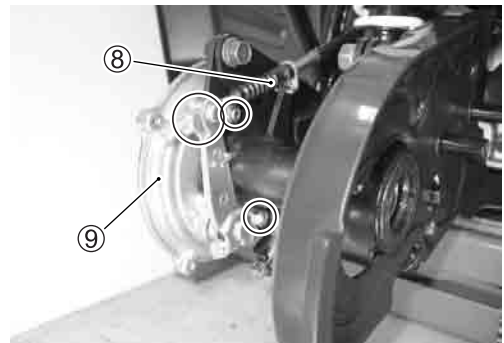



- Remove the rear brake cam lever bolt and cam lever.



- Remove the rear brake camshaft ⑩, brake lining indicator plate ⑪, spring ⑫ and O-rings ⑬.



- Remove the rear axle housing.

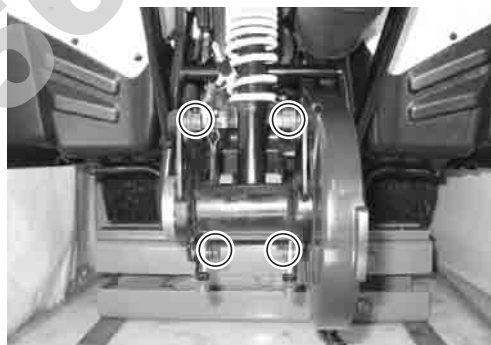

## INSPECTION AND DISASSEMBLY

### BRAKE DRUM

Inspect the brake drum and measure the brake drum I.D. to determine the extent of wear. Replace the brake drum if the measurement exceeds the service limit. The value of this limit is indicated inside the brake drum.

**TOOL** 09900-20101: Vernier calipers

**DATA** Brake drum I.D.:  
Service Limit: 110.7 mm (4.36 in)



**BRAKE SHOE**

Inspect the brake shoes for wear or damage. If any wear or defects are found, replace the brake shoes as a set.

**CAUTION**

Replace the brake shoes as a set. Otherwise braking performance will be adversely affected.

**REAR AXLE**

Support the rear axle with the V-blocks and measure the rear axle runout with the dial gauge as shown. If the runout exceeds the service limit, replace the rear axle with a new one.

**TOOL** 09900-20607: Dial gauge (1/100 mm)  
09900-20701: Magnetic stand  
09900-21304: V-block set (100 mm)

**DATA** Rear axle runout:  
Service Limit: 3 mm (0.12 in)

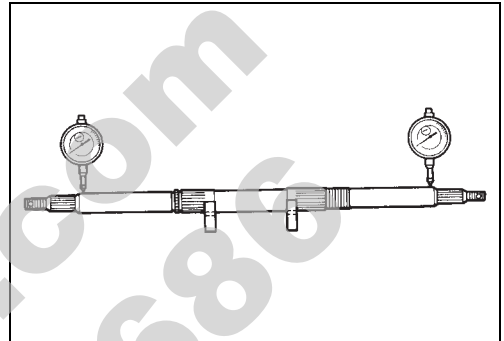
**STOPPER RING**

Inspect the stopper ring for wear or damage. If any wear or defects are found, replace it with a new one.

**CAUTION**

The removed stopper ring must be replaced with a new one.

**REAR SPROCKET**

Inspect the sprocket teeth for wear. If they are worn as illustrated, replace the sprocket and drive chain.

- Ⓐ: Normal wear
- Ⓑ: Excessive wear

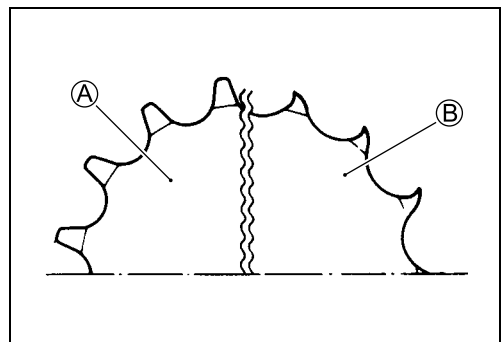

- Unlock the rear sprocket washer ①.
- Remove the bolts and rear sprocket ②.
- Remove the rear sprocket washer ①.

**CAUTION**

The removed rear sprocket washer must be replaced with new ones.

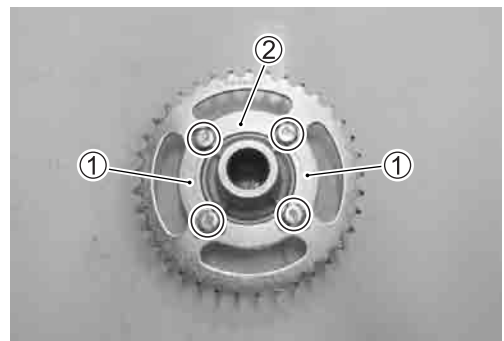

**DUST SEAL**

- Remove the dust seals with the special tool.

**TOOL** 09913-50121: Oil seal remover

**CAUTION**

The removed dust seals must be replaced with new ones.

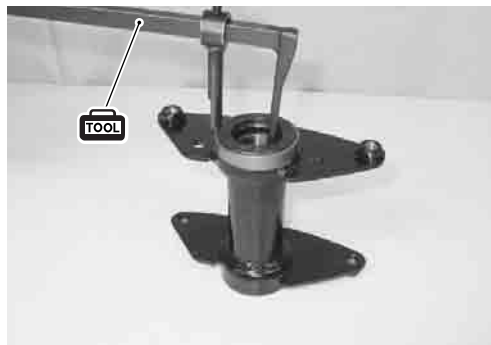
**BEARING**

Inspect the play (A) of the rear axle housing bearings by finger while they are in the rear axle housing. Rotate the inner race by finger to inspect it for abnormal noise and smooth rotation. If there is anything unusual, replace the bearing with a new one.

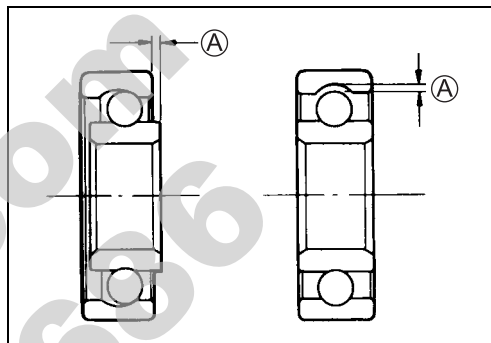

- Remove the rear axle housing bearings with the special tool.

**TOOL** 09921-20240: Bearing remover set

**CAUTION**

The removed bearings should be replaced with new ones.

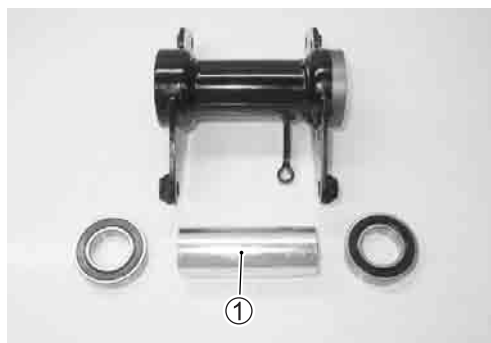

- Remove the spacer (1).

**REASSEMBLY AND REMOUNTING**

Reassemble and remount the rear brake and rear axle housing in the reverse order of removal and disassembly.

Pay attention to the following points:

**BEARING AND REAR AXLE HOUSING**

- Apply SUZUKI SUPER GREASE "A" to the rear axle housing bearings and the lip of the dust seals before installing them.

**TOOL** 99000-25010: SUZUKI SUPER GREASE "A" or equivalent

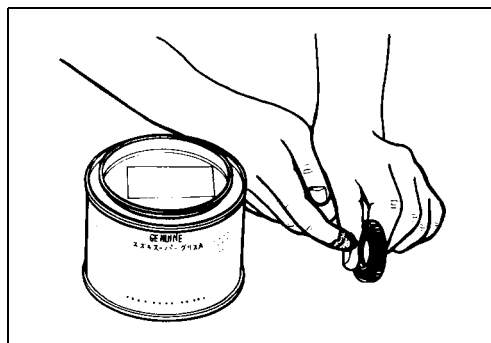

- Install the rear axle housing bearing with the special tool.
- Install the dust seals with the special tool.

**TOOL** 09924-84510: Bearing installer set

### CAUTION

- \* First install the left bearing ①, then install the spacer ② and right bearing ③.
- \* The sealed cover of the bearing must face outside.

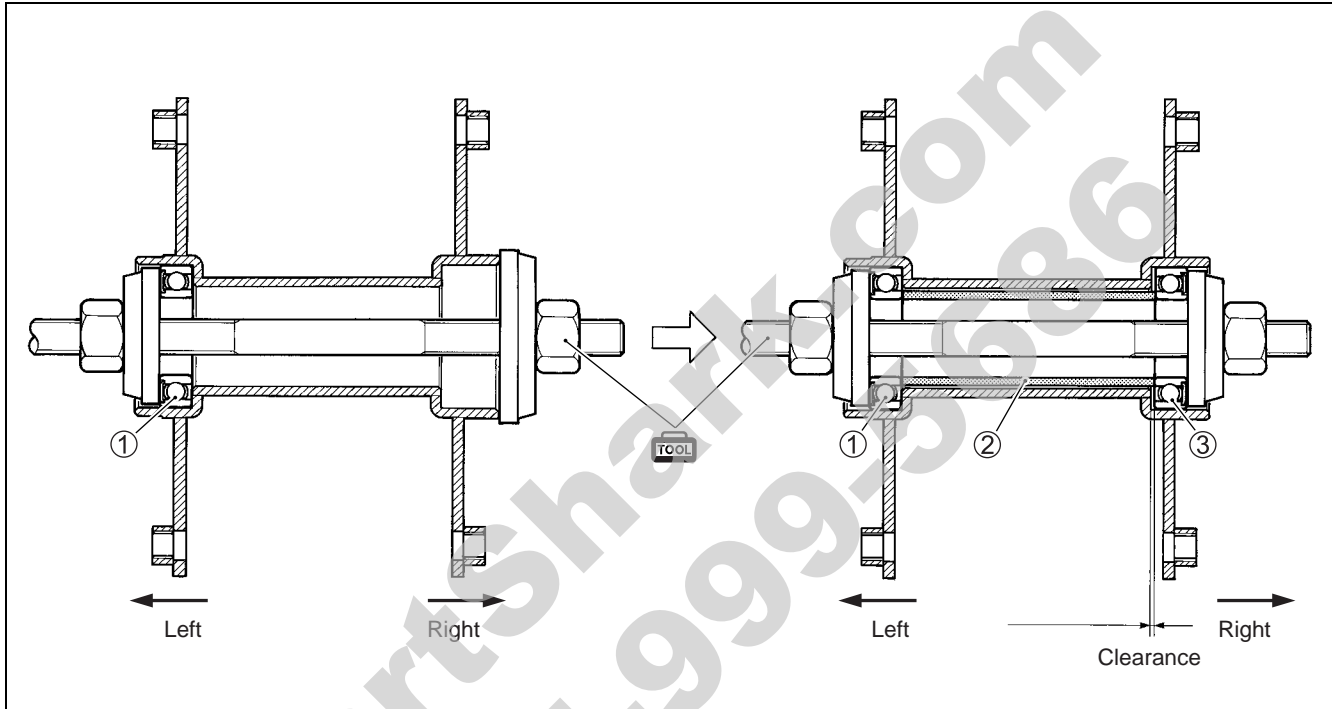

- Tighten the rear axle housing bolts to the specified torque.

**U** Rear axle housing bolt: 50 N·m (5.0 kgf·m, 36.0 lb-ft)

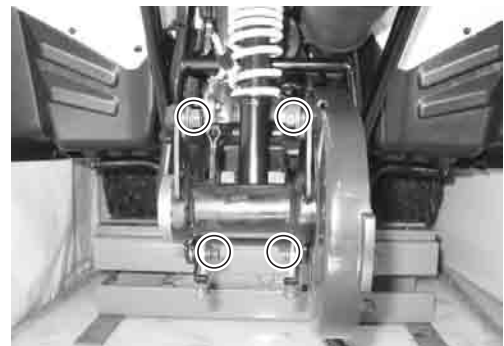

### REAR BRAKE

- Apply SUZUKI SUPER GREASE "A" to the rear brake camshaft and new O-rings.

**AH** 99000-25010: SUZUKI SUPER GREASE "A" or equivalent

- Install the new O-rings into the brake camshaft hole.

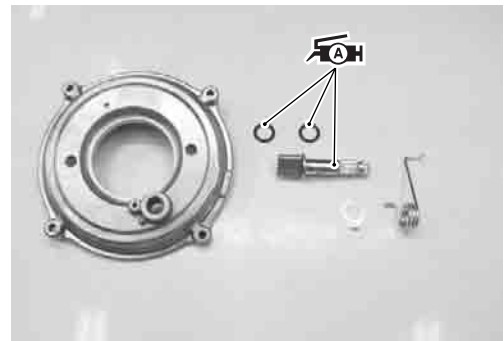

**NOTE:**

Face the groove on the camshaft to the inside.

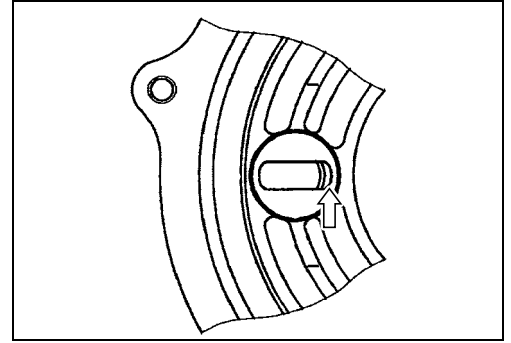

- Install the brake lining indicator plate ①, spring ② and rear brake cam lever ③.
- Align the punched mark ① on the cam lever with the slit ② on the camshaft.

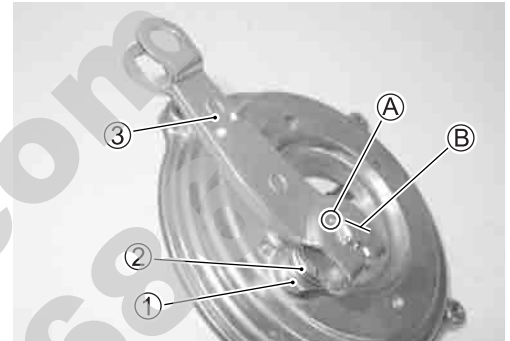
**NOTE:**

Align the groove ③ on the camshaft with the tongue ④ of the indicator plate.

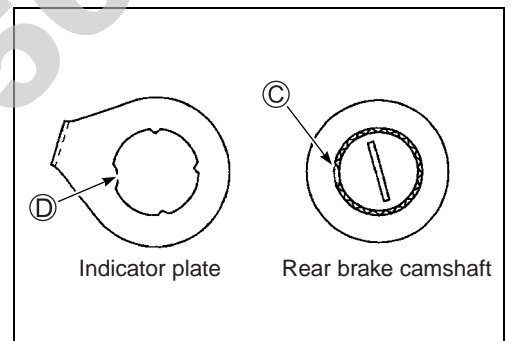

- Tighten the rear brake cam lever nut to the specified torque.

 **Rear brake cam lever nut: 7.7 N·m (0.77 kgf·m, 5.5 lb-ft)**



- Tighten the rear brake panel nut to the specified torque.

 **Rear brake panel nut: 28 N·m (2.8 kgf·m, 20.0 lb-ft)**

- Connect the rear brake cable.

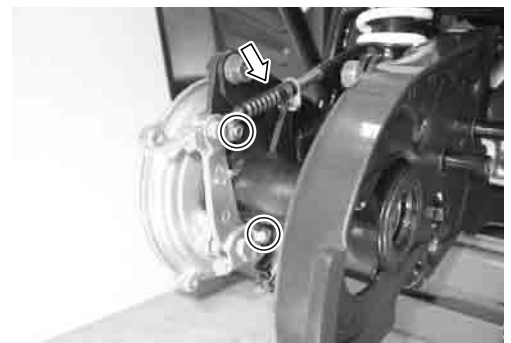

- Apply SUZUKI SUPER GREASE "A" to the brake camshaft and pin.

 99000-25010: SUZUKI SUPER GREASE "A" or equivalent

- Install the brake shoes.

**⚠ WARNING**

Be careful not to apply too much grease to the cam and pin. If grease gets on the lining, brake slippage will result.

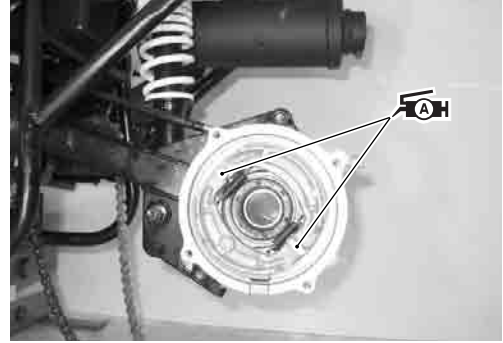

**REAR SPROCKET AND REAR AXLE**

- The stamped mark on the rear sprocket ① should face outside.
- Tighten the rear sprocket bolt to the specified torque.

 **Rear sprocket bolt: 23 N·m (2.3 kgf·m, 16.5 lb-ft)**

- Bend the rear sprocket washers ②.

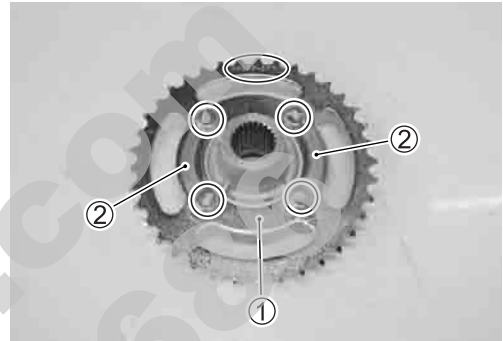

- Install the new stopper ring ③ and rear sprocket ①.

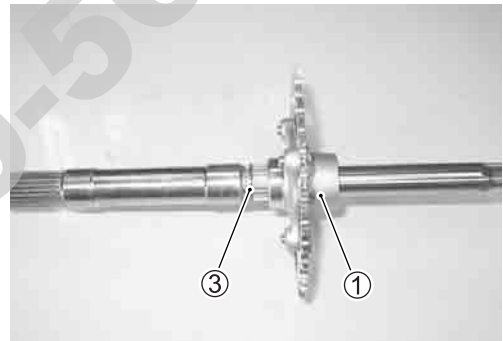

- Install the rear axle.

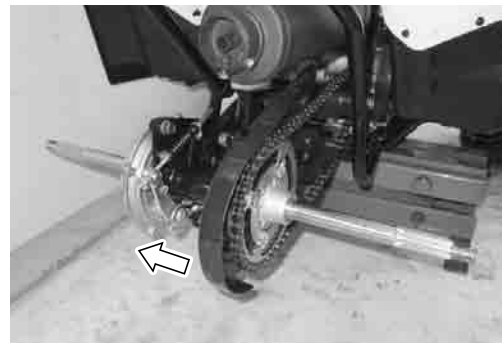

- Install the spacers left ④ and right ⑤.

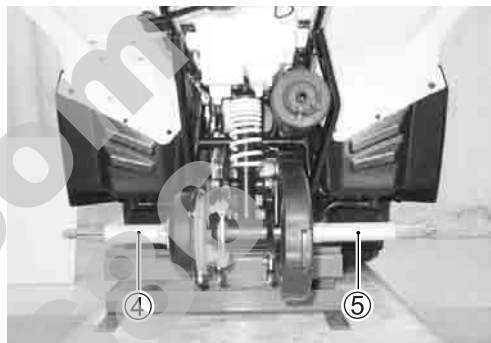
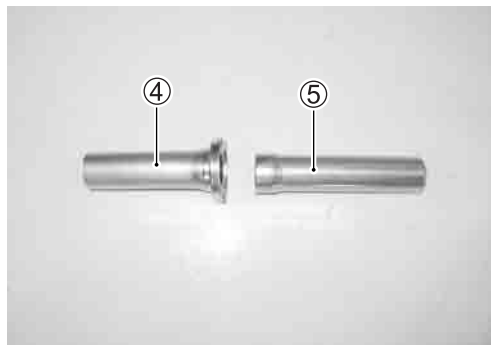

- Tighten the rear hub nut to the specified torque.

**🔧 Rear hub nut: 75 N·m (7.5 kgf·m, 54.0 lb-ft)**

- Install the new cotter pin.

*NOTE:*

*Bend the cotter pin to outside.*



- After installing the rear brake and rear axle housing, adjust the following items.

- \* Rear brake lever play ..... 📄 2-17
- \* Drive chain slack ..... 📄 2-14 to -16



# REAR SUSPENSION CONSTRUCTION

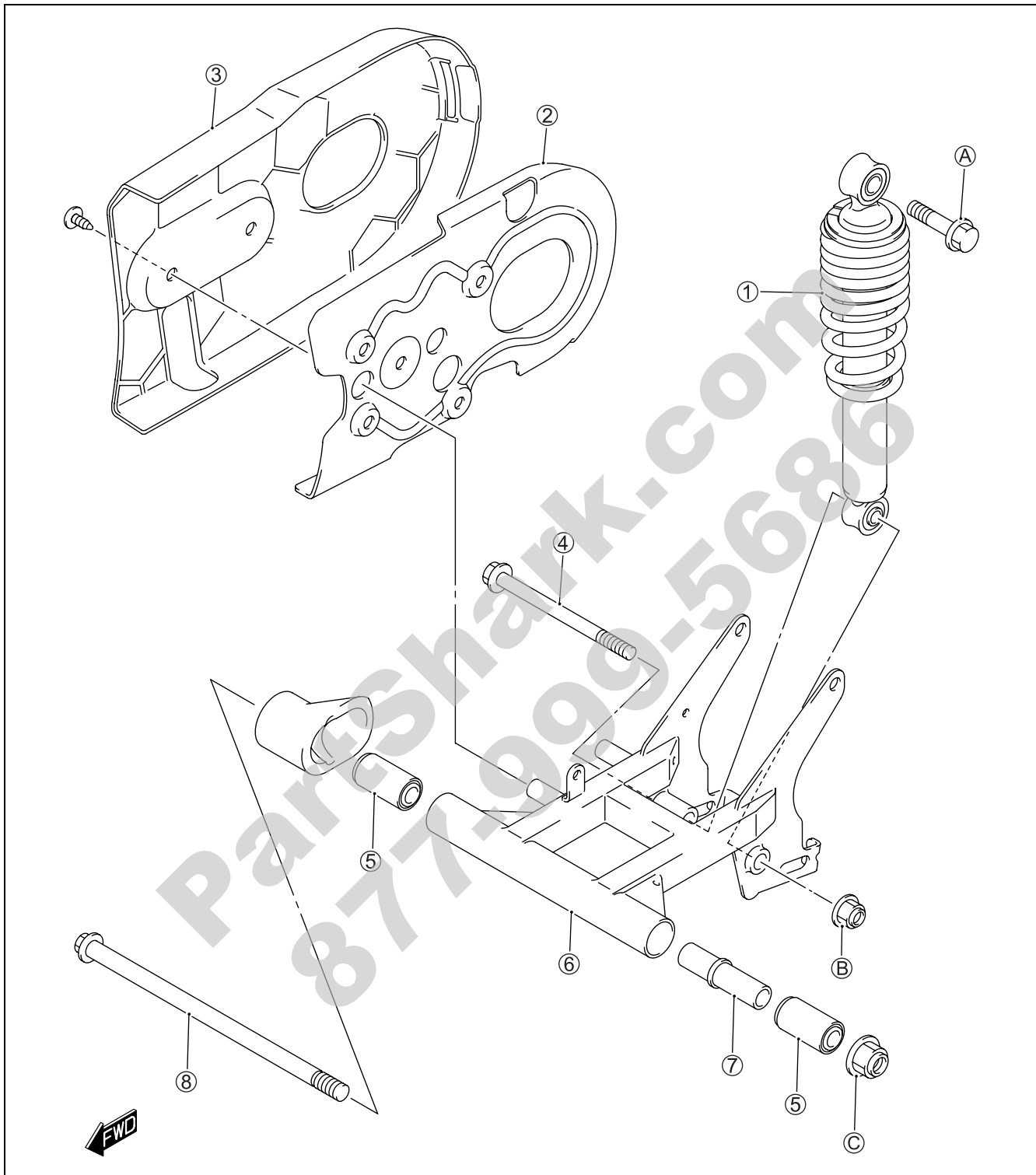

①	Rear shock absorber	⑦	Spacer
②	Chain case	⑧	Swingarm pivot shaft
③	Chain case cover	Ⓐ	Rear shock absorber bolt
④	Rear shock absorber lower bolt	Ⓑ	Rear shock absorber nut
⑤	Swingarm pivot bushing	Ⓒ	Swingarm pivot nut
⑥	Swingarm		

ITEM	N-m	kgf-m	lb-ft
Ⓐ	29	2.9	21.0
Ⓑ	29	2.9	21.0
Ⓒ	102	10.2	74.0

## REMOVAL AND DISASSEMBLY

- Remove the rear brake and rear axle housing. (☞ 5-31 and 5-32)
- Remove the chain case ①.

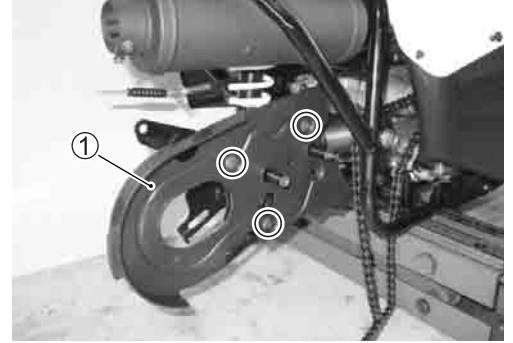

- Remove the rear shock absorber lower bolt ②.

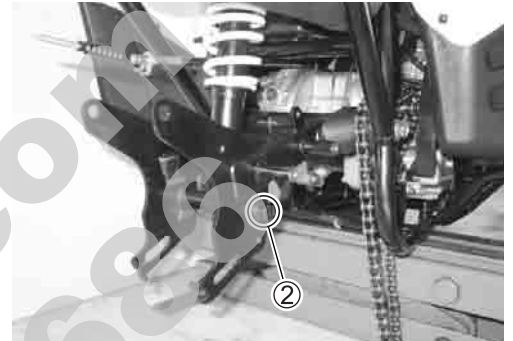

- Remove the rear shock absorber bolt ③.
- Remove the rear shock absorber ④.

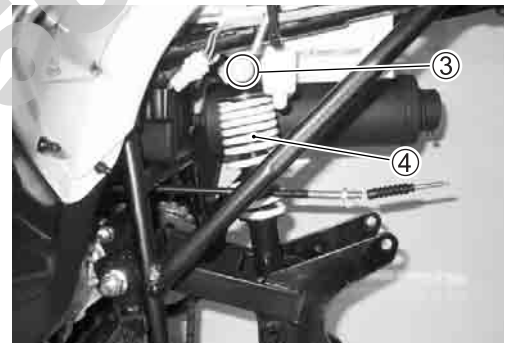

- Remove the swingarm pivot nut ⑤ and shaft.
- Remove the swingarm ⑥.

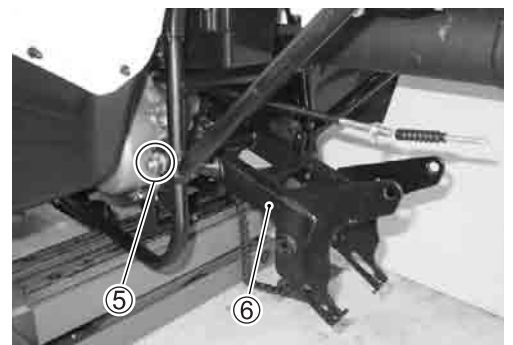

## INSPECTION

### REAR SHOCK ABSORBER

Inspect the shock absorber body and bushing for damage and oil leakage. If any defects are found, replace it with a new one.

#### CAUTION

**Do not attempt to disassemble the rear shock absorber. It is unserviceable.**



### SWINGARM PIVOT SHAFT

Check the pivot shaft for runout with a dial gauge and replace it if the runout exceeds the limit.

**TOOL** 09900-20607: Dial gauge (1/100 mm)  
 09900-20701: Magnetic stand  
 09900-21304: V-block set (100 mm)

**DATA** Swingarm pivot shaft runout:  
 Service Limit: 0.6 mm (0.02 in)

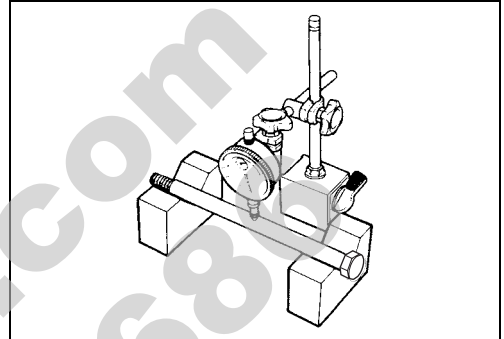

### SWINGARM

Inspect the swingarm for distortion or damage. If any defects are found, replace it with a new one.



### BUSHING

Inspect the bushing for wear or damage. If any defects are found, replace it with a new one.

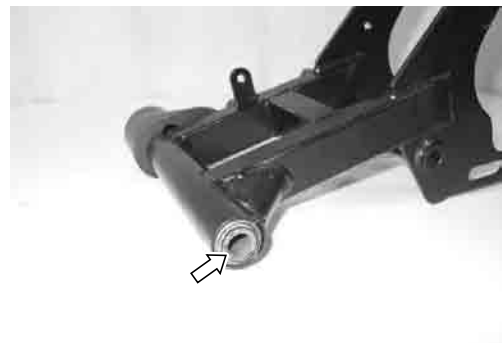

## REASSEMBLY AND REMOUNTING

Reassemble and remount the rear suspension in the reverse order of removal and disassembly. Pay attention to the following points:

- Install the swingarm pivot bushings with the special tool.

 **09941-34513: Steering race installer**



**NOTE:**

When installing the swingarm bushings ① to the swingarm ②, and confirm the distance between the end of the swingarm ② and bushing edge ③ is 1.5 mm (0.059 in).

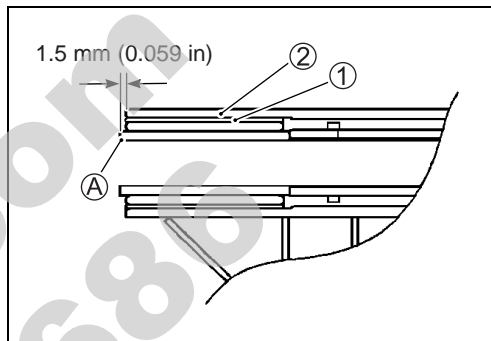

- Tighten the swingarm pivot nut to the specified torque.

 **Swingarm pivot nut: 102 N·m (10.2 kgf·m, 74.0 lb-ft)**



- Tighten the rear shock absorber bolt to the specified torque.

 **Rear shock absorber bolt: 29 N·m (2.9 kgf·m, 21.0 lb-ft)**



- Tighten the rear shock absorber nut to the specified torque.

 **Rear shock absorber nut: 29 N·m (2.9 kgf·m, 21.0 lb-ft)**



- Install the rear axle housing and rear brake. (☞ 5-35 to -37)
- After installing the rear suspension, adjust the following items.
  - \* Rear brake lever play ..... ☞ 2-17
  - \* Drive chain slack..... ☞ 2-15

PartShark.com  
877-999-5686

# ELECTRICAL SYSTEM

## CONTENTS

<b>CAUTIONS IN SERVICING</b> .....	6- 2
<b>CONNECTOR</b> .....	6- 2
<b>COUPLER</b> .....	6- 2
<b>CLAMP</b> .....	6- 2
<b>FUSE</b> .....	6- 2
<b>SEMI-CONDUCTOR EQUIPPED PART</b> .....	6- 3
<b>BATTERY</b> .....	6- 3
<b>CONNECTING THE BATTERY</b> .....	6- 3
<b>WIRING PROCEDURE</b> .....	6- 3
<b>USING THE MULTI-CIRCUIT TESTER</b> .....	6- 4
<b>LOCATION OF ELECTRICAL COMPONENTS</b> .....	6- 5
<b>CHARGING SYSTEM</b> .....	6- 7
<b>TROUBLESHOOTING</b> .....	6- 7
<b>INSPECTION</b> .....	6- 8
<b>STARTER SYSTEM</b> .....	6-11
<b>TROUBLESHOOTING</b> .....	6-11
<b>STARTER MOTOR REMOVAL</b> .....	6-12
<b>STARTER MOTOR DISASSEMBLY</b> .....	6-13
<b>STARTER MOTOR INSPECTION</b> .....	6-14
<b>STARTER MOTOR REASSEMBLY</b> .....	6-15
<b>STARTER MOTOR INSTALLATION</b> .....	6-16
<b>STARTER RELAY INSPECTION</b> .....	6-16
<b>IGNITION SYSTEM</b> .....	6-18
<b>TROUBLESHOOTING</b> .....	6-18
<b>INSPECTION</b> .....	6-20
<b>SWITCHES</b> .....	6-23
<b>BATTERY</b> .....	6-24
<b>SPECIFICATIONS</b> .....	6-24
<b>INITIAL CHARGING</b> .....	6-24
<b>SERVICING</b> .....	6-26
<b>RECHARGING OPERATION</b> .....	6-26

## CAUTIONS IN SERVICING

### CONNECTOR

- When disconnecting a connector, be sure to hold the terminals and do not pull the lead wires.
- When connecting a connector, be sure to push it in until a click is felt.
- Inspect the connector for corrosion, contamination and breakage in its cover.

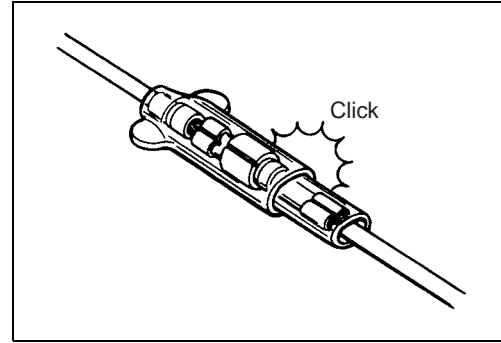

### COUPLER

- With a lock type coupler, be sure to release the lock when disconnecting, and push in fully to engage the lock when connecting.
- When disconnecting the coupler, be sure to hold the coupler itself and do not pull the lead wires.
- Inspect each terminal on the coupler for being loose or bent.
- Inspect each terminal for corrosion and contamination.

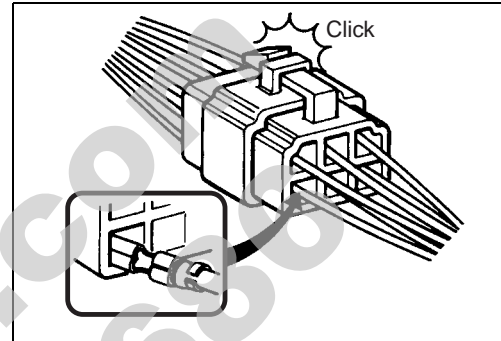

### CLAMP

- Clamp the wiring harness at such positions as indicated in "WIRING HARNESS ROUTING". (☞ 7-14)
- Bend the clamp properly so that the wiring harness is clamped securely.
- In clamping the wiring harness, use care not to allow it to hang down.
- Do not use wire or any other substitute for the band type clamp.

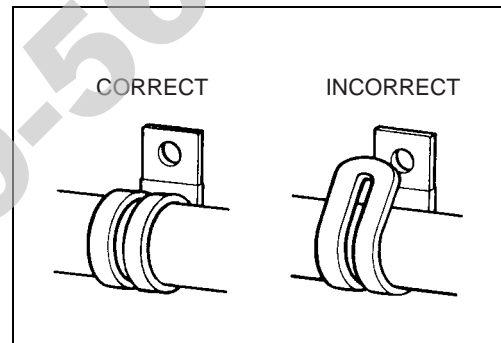

### FUSE

- When a fuse blows, always investigate the cause to correct it and then replace the fuse.
- Do not use a fuse of a different capacity.
- Do not use wire or any other substitute for the fuse.

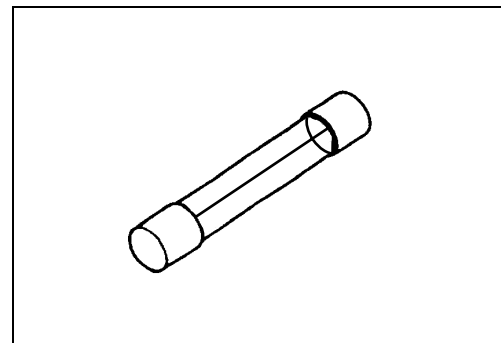



## SEMI-CONDUCTOR EQUIPPED PART

- Be careful not to drop the part with a semi-conductor built in such as a CDI unit and regulator/rectifier.
- When inspecting this part, follow inspection instruction strictly. Neglecting proper procedure may cause damage to this part.

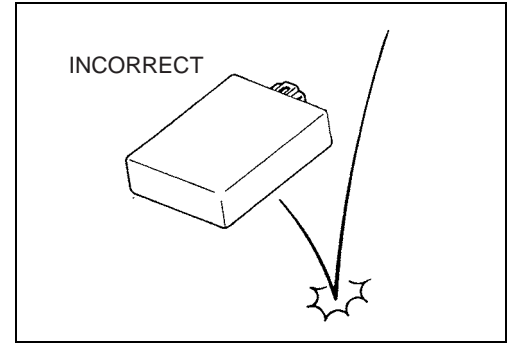

## BATTERY

- The MF battery used in this vehicle does not require maintenance (e.g., electrolyte level inspection, distilled water replenishment).
- During normal charging, no hydrogen gas is produced. However, if the battery is overcharged, hydrogen gas may be produced. Therefore, be sure there are no fire or spark sources (e.g., short circuit) nearby when charging the battery.
- Be sure to recharge the battery in a well-ventilated and open area.
- Note that the charging system for the MF battery is different from that of a conventional battery. Do not replace the MF battery with a conventional battery.

## CONNECTING THE BATTERY

- When disconnecting terminals from the battery for disassembly or servicing, be sure to disconnect the  $\ominus$  battery lead wire, first.
- When connecting the battery lead wires, be sure to connect the  $\oplus$  battery lead wire, first.
- If the terminal is corroded, remove the battery, pour warm water over it and clean it with a wire brush.
- After connecting the battery, apply a light coat of grease to the battery terminals.
- Install the cover over the  $\oplus$  battery terminal.

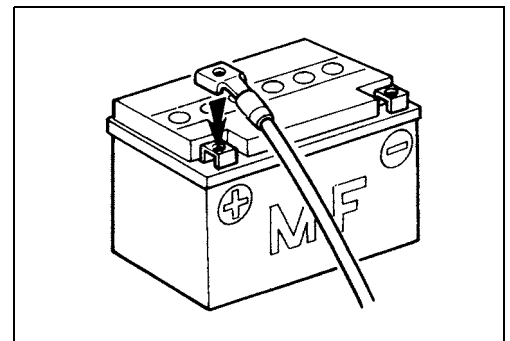
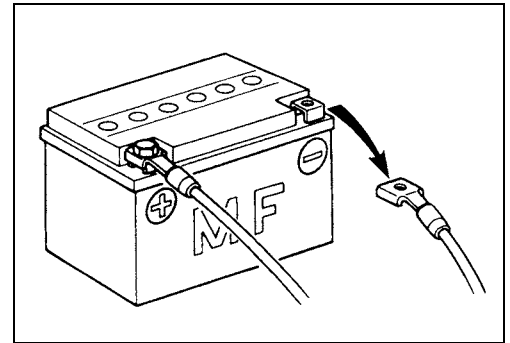

## WIRING PROCEDURE

- Properly route the wiring harness according to the "WIRING HARNESS ROUTING" section. (7-14)

## USING THE MULTI-CIRCUIT TESTER

- Properly use the multi-circuit tester  $\oplus$  and  $\ominus$  probes. Improper use can cause damage to the vehicle and tester.
- If the voltage and current values are not known, begin measuring in the highest range.
- When measuring the resistance, make sure that no voltage is applied. If voltage is applied, the tester will be damaged.
- After using the tester, be sure to turn the switch to the OFF position.

 **09900-25008: Multi-circuit tester set**

### CAUTION

**Before using the multi-circuit tester, read its instruction manual.**

### NOTE:

- \* *When connecting the multi-circuit tester, use the needle pointed probe to the back side of the lead wire coupler and connect the probes of tester to them.*
- \* *Use the needle pointed probe to prevent the rubber of the water proof coupler from damage.*

 **09900-25009: Needle pointed probe set**

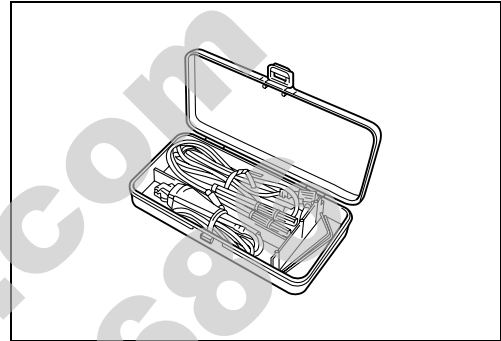
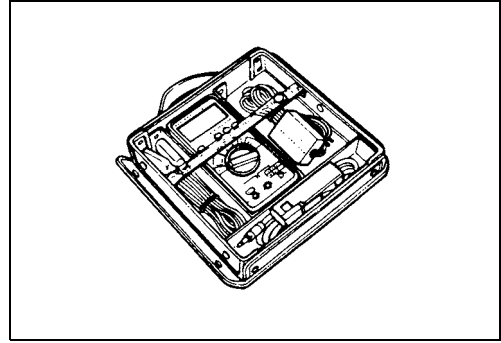

PartShark.com  
877-999-5688

# LOCATION OF ELECTRICAL COMPONENTS

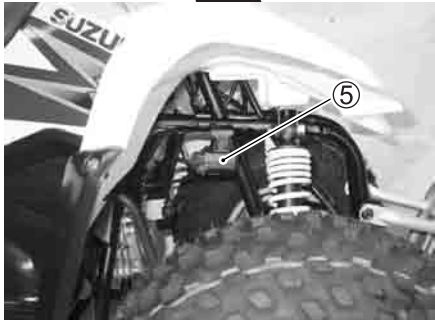
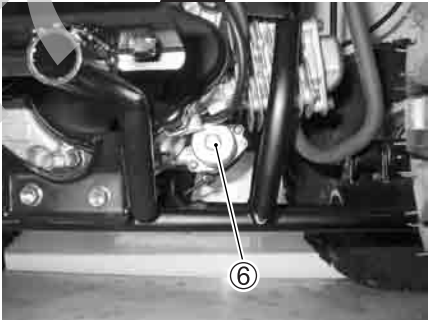
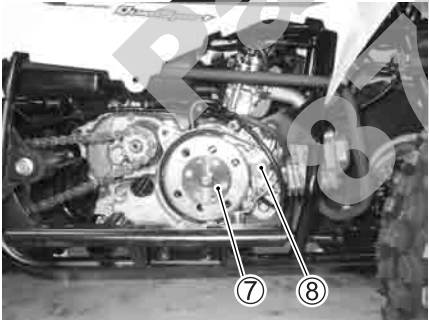
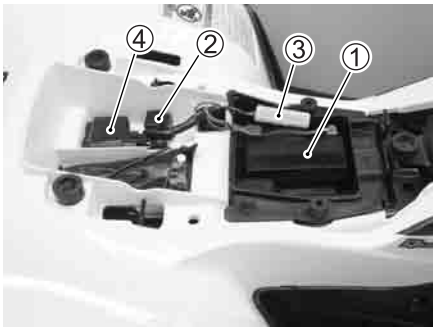

- ① Battery
- ② Starter relay
- ③ Fuse box
- ④ CDI unit

- ⑤ Ignition coil
- ⑥ Starter motor
- ⑦ Generator
- ⑧ Pick-up coil

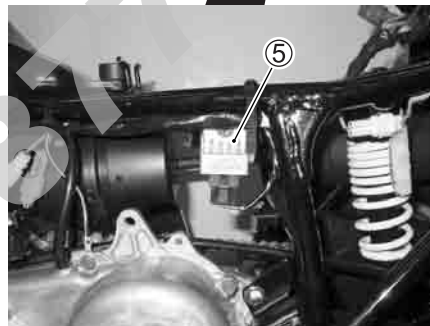
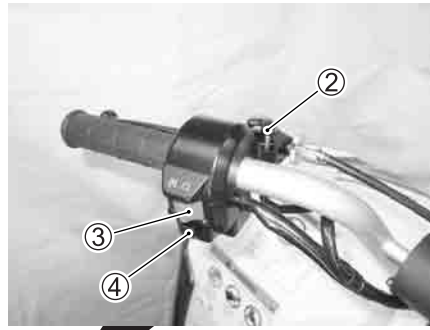
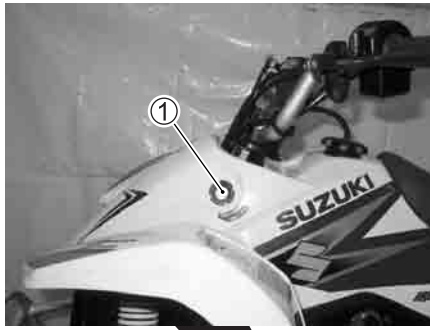

- ① Ignition switch
- ② Parking brake switch
- ③ Engine stop switch

- ④ Starter button
- ⑤ Regulator/rectifier
- ⑥ Remote engine stop switch

## CHARGING SYSTEM

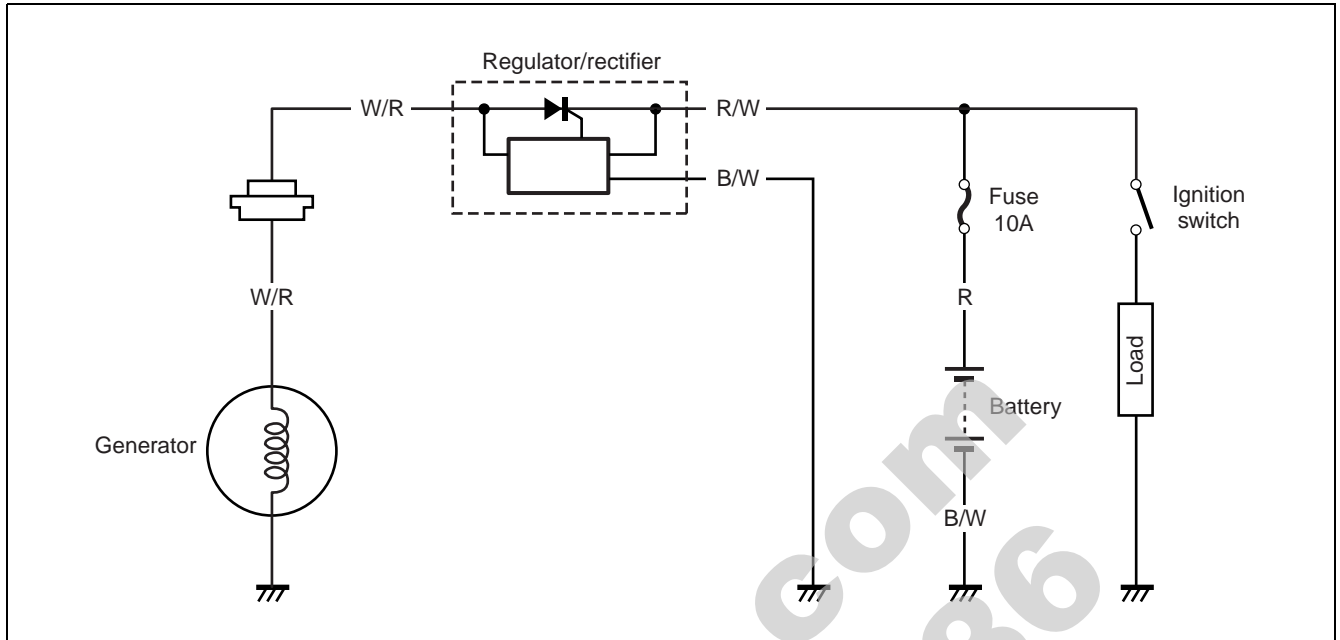

## TROUBLESHOOTING

### Battery runs down quickly

#### Step 1

- 1) Check accessories which use excessive amounts of electricity.

Are accessories being installed?

YES	Remove accessories.
NO	Go to Step 2.

#### Step 2

- 1) Check the battery for current leaks. (☞ 6-8)

Is the battery current leaks OK?

YES	Go to Step 3.
NO	<ul style="list-style-type: none"> <li>• Short circuit of wiring harness.</li> <li>• Faulty electrical equipment.</li> </ul>

#### Step 3

- 1) Measure the regulated voltage between the battery terminals. (☞ 6-9)

Is the regulated voltage OK?

YES	<ul style="list-style-type: none"> <li>• Faulty battery.</li> <li>• Abnormal driving condition.</li> </ul>
NO	Go to Step 4.

#### Step 4

- 1) Measure the resistance of the generator coil. (☞ 6-9)

Is the resistance of generator coil OK?

YES	Go to Step 5.
NO	<ul style="list-style-type: none"> <li>• Faulty generator coil.</li> <li>• Disconnected lead wires.</li> </ul>

**Step 5**

1) Measure the generator no-load performance. (☞6-10)

Is the generator no-load performance OK?

YES	Go to Step 6.
NO	Faulty generator.

**Step 6**

1) Inspect the regulator/rectifier. (☞6-10)

Is the regulator/rectifier OK?

YES	Go to Step 7.
NO	Faulty regulator/rectifier.

**Step 7**

1) Inspect wiring harness.

Is the wiring harness OK?

YES	Faulty battery.
NO	<ul style="list-style-type: none"> <li>• Short circuit of wiring harness.</li> <li>• Poor contact of couplers.</li> </ul>

**Battery overcharges**

- Faulty regulator/rectifier.
- Faulty battery.
- Poor contact of regulator/rectifier lead wire coupler.

**INSPECTION****BATTERY CURRENT LEAKAGE**

- Remove the seat. (☞5-4)
- Turn the ignition switch to the OFF position.
- Disconnect the battery  $\ominus$  lead wire ①.

Measure the current between  $\ominus$  battery terminal and the  $\ominus$  battery lead wire with the multi-circuit tester. If the reading exceeds the specified value, leakage is evident.

 **09900-25008: Multi-circuit tester set**

 **Tester knob indication: Current (---, 20 mA)**

 **Battery current (leak): Under 1 mA**

**CAUTION**

- \* In case of a large current leak, turn the tester to high range first to avoid tester damage.
- \* Do not turn the ignition switch to the "ON" position when measuring current.

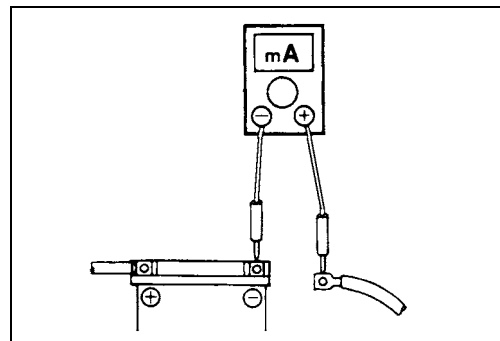

**REGULATED VOLTAGE**

- Remove the seat. (☞ 5-4)
- Start the engine and keep it running at 2 800 r/min.

Measure the DC voltage between the  $\oplus$  and  $\ominus$  battery terminals with the multi-circuit tester. If the voltage is not within the standard range, inspect the generator and regulator/rectifier. (☞ 6-9 and 6-10)

**NOTE:**

When making this test, be sure that the battery is in fully-charged condition.

**TOOL** 09900-25008: Multi-circuit tester set

**Tester knob indication: Voltage (V)**

**DATA** Regulated voltage (Charging output):

13.5 – 15.2 V at 2 800 r/min.

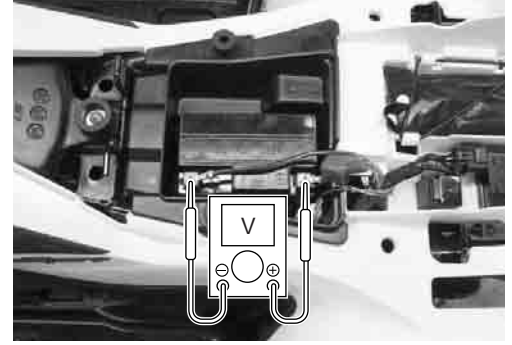
**GENERATOR COIL RESISTANCE**

- Remove the left frame cover. (☞ 5-4)
- Disconnect the generator coupler ①.

Measure the resistance between the W/R wire and ground with the multi-circuit tester.

If the resistance is not within the standard range, replace the generator coil with a new one.

**TOOL** 09900-25008: Multi-circuit tester set

**Tester knob indication: Resistance ( $\Omega$ )**

**DATA** Generator coil resistance: 0.5 – 2.0  $\Omega$  (W/R – Ground)

**NOTE:**

When making above test, it is not necessary to remove the generator.

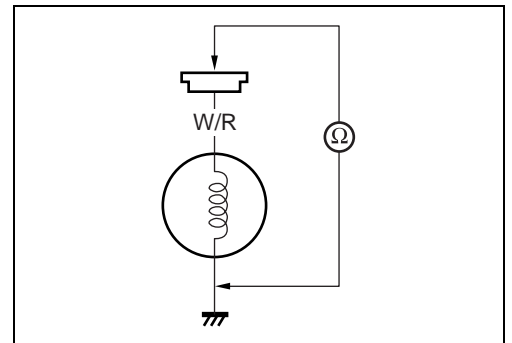



**GENERATOR NO-LOAD PERFORMANCE**

- Remove the left frame cover. (☞ 5-4)
- Disconnect the regulator/rectifier coupler ①.
- Start the engine and keep it running at 2 800 r/min.

Measure the voltage between W/R wire and ground with the multi-circuit tester.

If the tester reads under the specified value, replace the generator coil with a new one.

**TOOL** 09900-25008: Multi-circuit tester set

**Tester knob indication: Voltage (~)**

**DATA** Generator no-load performance:  
**20 V and more at 2 800 r/min (When engine is cold)**

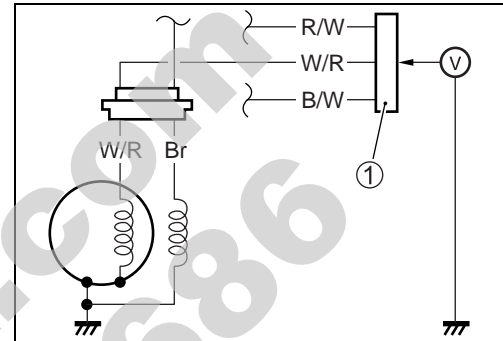
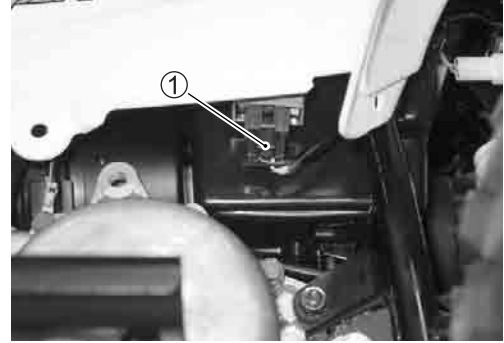

**REGULATOR/RECTIFIER**

- Remove the frame center cover. (☞ 5-5)
- Disconnect the regulator/rectifier coupler ①.
- Remove the regulator/rectifier ②.

Measure the voltage between the terminals with the multi-circuit tester as indicated in the table below. If the voltage is not within the specified value, replace the regulator/rectifier with a new one.

**TOOL** 09900-25008: Multi-circuit tester set

**Tester knob indication: Diode test (⚡)**

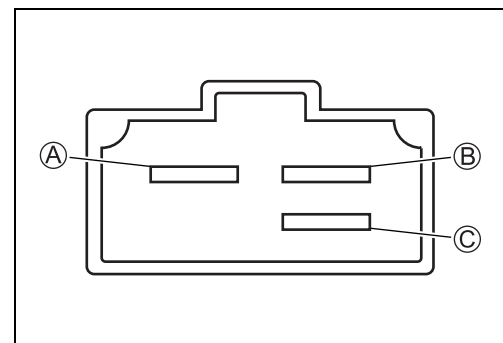
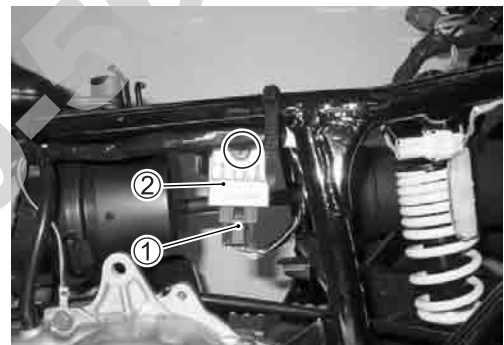

Unit: V

		⊕ Probe of tester to:		
		Ⓐ	Ⓑ	Ⓒ
⓪ Probe of tester to:	Ⓐ		*	*
	Ⓑ	*		1.3 – 1.6
	Ⓒ	*	0.9 – 1.4	

\*1.4 V and more (tester's battery voltage)

**NOTE:**

If the tester reads 1.4 V and below when the tester probes are not connected, replace its battery.

## STARTER SYSTEM

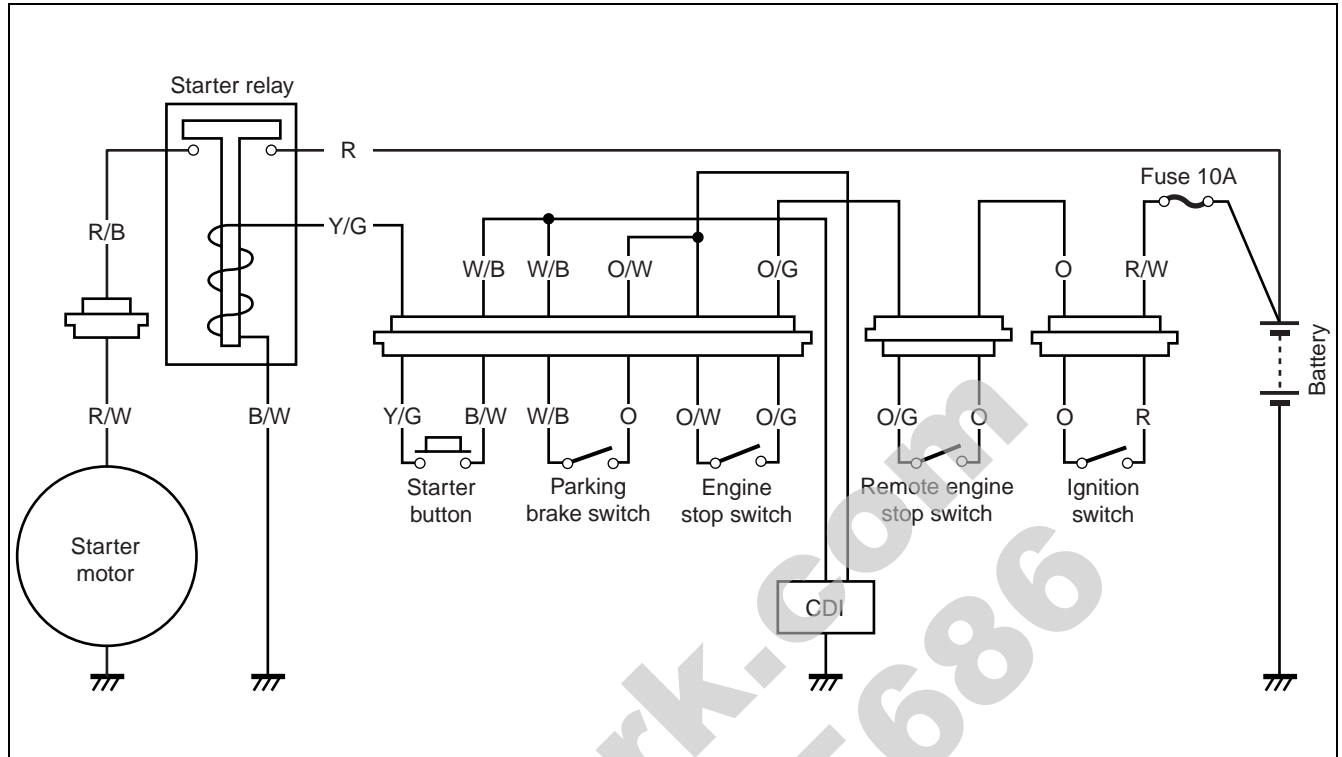

## TROUBLESHOOTING

Make sure that the fuse is not blown and the battery is fully-charged before diagnosing.

### Starter motor will not run

#### Step 1

- Turn on the ignition switch with the engine stop switch, parking brake switch and remote engine stop switch in the "RUN", "ON" and "SET" positions and listen for a click from the starter relay when the starter button is pushed.

Is a click sound heard?

YES	Go to Step 2.
NO	Go to Step 3.

#### Step 2

- Check if the starter motor runs when its terminal is connected to the battery  $\oplus$  terminal.

Does the starter motor run?

YES	<ul style="list-style-type: none"> <li>Faulty starter relay.</li> <li>Loose or disconnected starter motor lead wire.</li> <li>Loose or disconnected between starter relay and battery <math>\oplus</math> terminal.</li> </ul>
NO	Faulty starter motor.

**Step 3**

1) Measure the starter relay voltage at the starter relay connectors (between Y/G ⊕ and B/W ⊖) when the starter button is pushed.

Is a voltage OK?

YES	Go to Step 4.
NO	<ul style="list-style-type: none"> <li>• Faulty engine stop switch.</li> <li>• Faulty starter button.</li> <li>• Faulty parking brake switch.</li> <li>• Faulty remote engine stop switch.</li> <li>• Faulty ignition switch.</li> <li>• Poor contact of connector.</li> <li>• Open circuit in wiring harness.</li> </ul>

**Step 4**

1) Check the starter relay. (☞ 6-16 to -17)

Is the starter relay OK?

YES	Poor contact of the starter relay.
NO	Faulty starter relay.

**Engine does not turn though the starter motor runs.**

- Faulty starter pinion. (☞ 3-34)

**STARTER MOTOR REMOVAL**

- Disconnect the battery ⊖ lead wire.
- Remove the right frame cover. (☞ 5-4)
- Remove the starter motor ①.

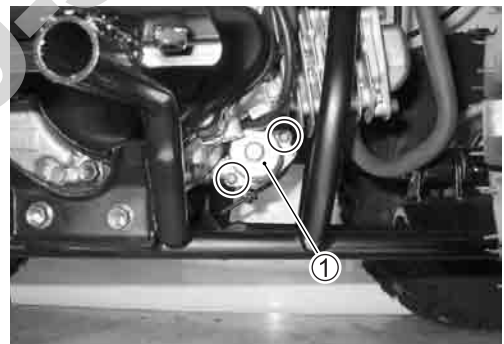

- Disconnect the starter motor lead wire ②.

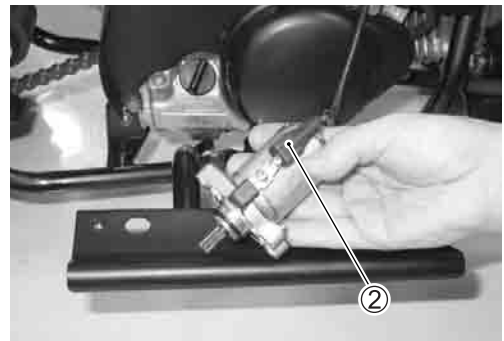

## STARTER MOTOR DISASSEMBLY

- Disassemble the starter motor as shown in the illustration.

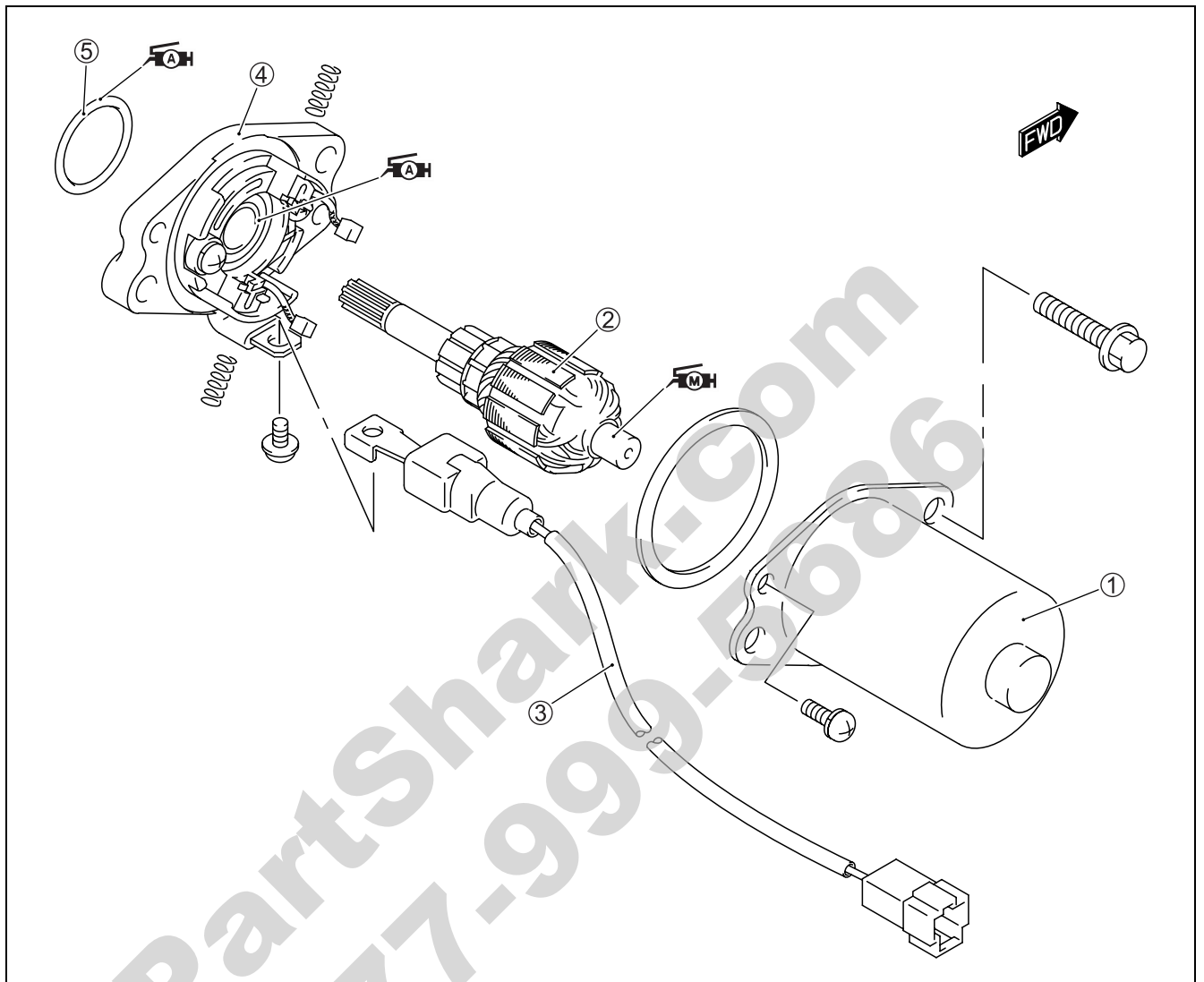

①	Starter motor case	④	Housing end assembly
②	Armature	⑤	O-ring
③	Starter motor lead wire		

## STARTER MOTOR INSPECTION

### CARBON BRUSH

Inspect the brushes for abnormal wear, cracks or smoothness in the brush holder.

If any defects are found, replace the housing end assembly with a new one.

Measure the brush length with a vernier calipers. If brush length is less than the service limit, replace the housing end assembly with a new one.

**TOOL** 09900-20101: Vernier calipers

**DATA** Brush length

**Service Limit: 2.75 mm (0.108 in)**

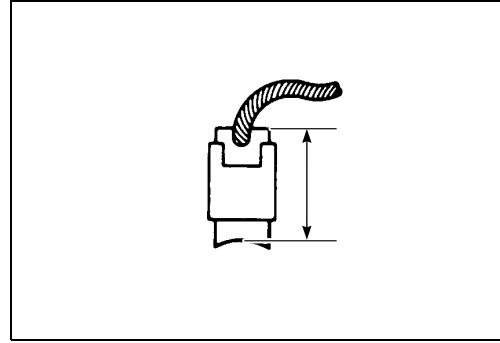

### COMMUTATOR

Inspect the commutator for discoloration, abnormal wear or undercut (A).

If abnormal wear is found, replace the armature with a new one.

If the commutator surface is discolored, polish it with #400 sand paper and wipe it with a clean dry cloth.

If there is no undercut, scrape out the insulator with a saw blade.

- ① Insulator
- ② Segment

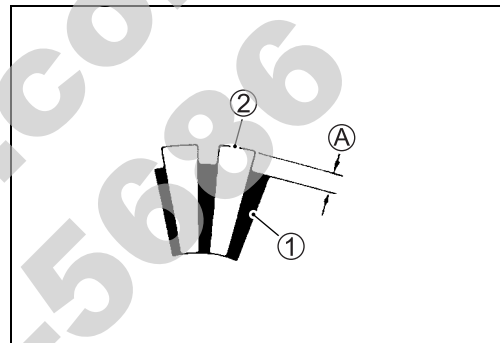

### ARMATURE COIL INSPECTION

Check for continuity between each segment and between each segment and the armature shaft with the multi-circuit tester.

If there is no continuity between the segments or there is continuity between the segments and shaft, replace the armature with a new one.

**TOOL** 09900-25008: Multi-circuit tester set

**Tester knob indication: Continuity test (••••)**

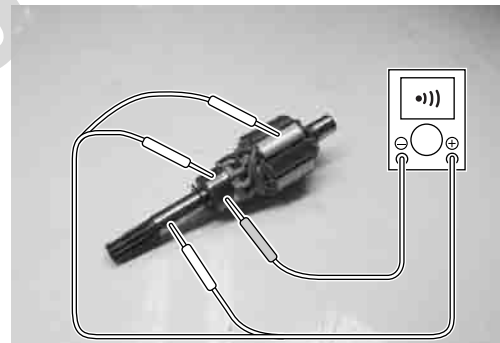

### BEARING

Inspect the bearing for wear or damage.

Check the smooth rotation of the bearing by finger.

If any wear or damage is found, replace the housing end assembly.



**OIL SEAL INSPECTION**

Check the oil seal lip for damage or leakage.

If any defects are found, replace the housing end assembly.

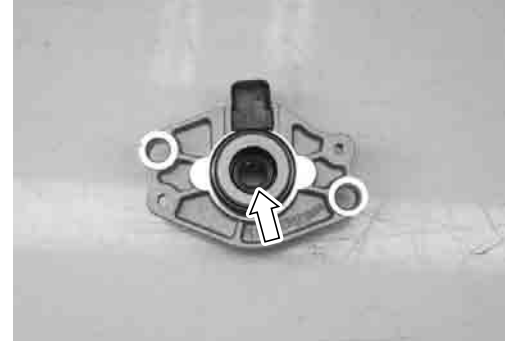
**BUSHING**

Inspect the bushing for wear or damage.

If any wear or damage is found, replace the starter motor with a new one.

**STARTER MOTOR REASSEMBLY**

Reassemble the starter motor in the reverse order of disassembly. Pay attention to the following points:

- Apply SUZUKI SUPER GREASE "A" to the lip of the oil seal.

 99000-25010: SUZUKI SUPER GREASE "A" or equivalent



- Apply a small quantity of SUZUKI MOLY PASTE to the armature shaft.

 99000-25140: SUZUKI MOLY PASTE or equivalent



- Apply SUZUKI SUPER GREASE "A" to the O-ring.

 99000-25010: SUZUKI SUPER GREASE "A" or equivalent



## STARTER MOTOR INSTALLATION

- Tighten the starter motor lead wire screw ① and starter motor mounting bolts ②.

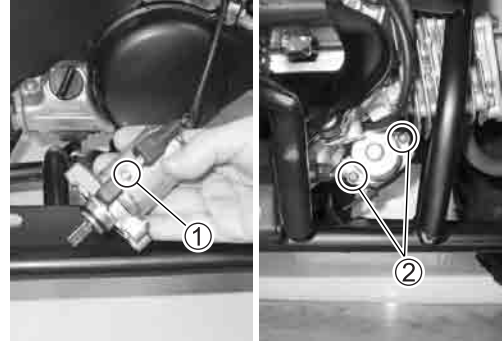

## STARTER RELAY INSPECTION

- Remove the seat. (☞ 5-4)
- Remove the starter relay ① from the frame center cover.



- Disconnect the starter relay coupler ②.

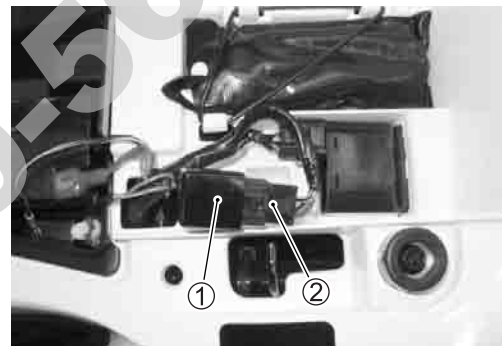

First check the insulation between Ⓐ and Ⓑ terminals with the multi-circuit tester. Then apply 12 V to terminals as shown and check the continuity between Ⓐ and Ⓑ. If there is no continuity, replace the starter relay with a new one.

 **09900-25008: Multi-circuit tester set**

 **Tester knob indication: Continuity test (•••)**

### CAUTION

**Do not apply battery voltage to the starter relay for more than five seconds, since the relay coil may over-heat and get damaged.**

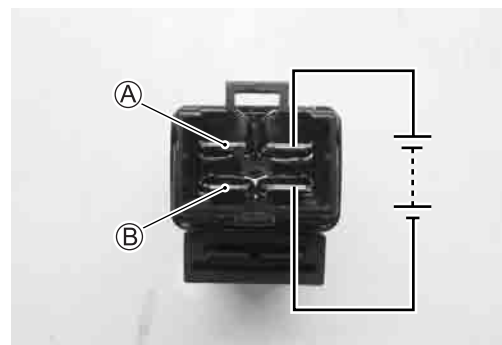



Measure the relay coil resistance between the terminals with the multi-circuit tester. If the resistance is not within the standard range, replace the starter relay with a new one.

**TOOL** 09900-25008: Multi-circuit tester set

**TESTER** Tester knob indication: Resistance ( $\Omega$ )

**DATA** Starter relay resistance: 70 – 90  $\Omega$

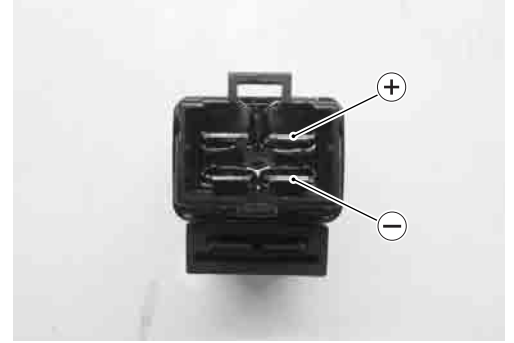

PartShark.com  
877-999-5686

## IGNITION SYSTEM

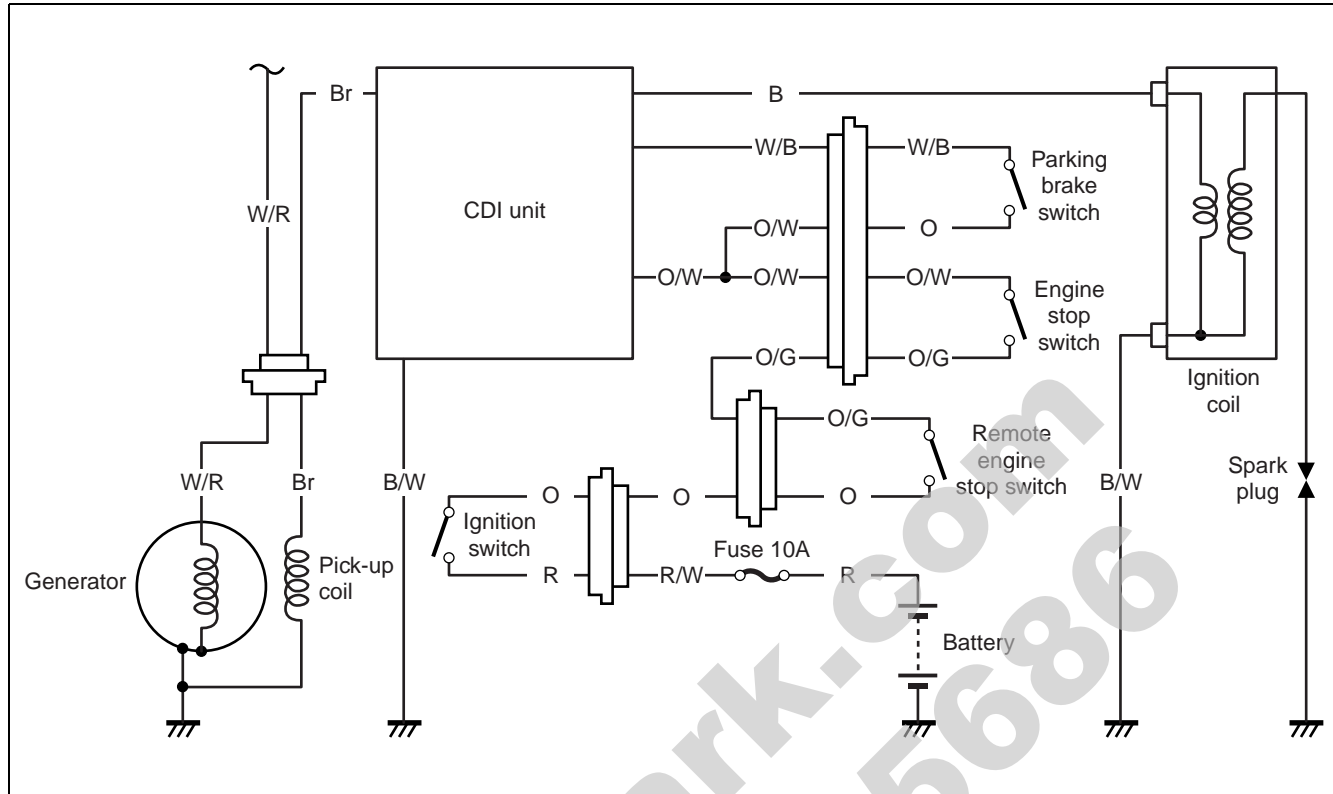

## TROUBLESHOOTING

### No spark or poor spark

#### NOTE:

Check that the engine stop switch, parking brake switch and remote engine stop switch are in the "RUN", "ON" and "SET" positions. Check that the fuse is not blown and the battery is fully-charged before diagnosing.

#### Step 1

1) Check the ignition system couplers for poor connections.

Is there connection in the ignition system couplers?

YES	Go to Step 2.
NO	Poor connection of couplers.

**Step 2**

1) Measure the battery voltage between input lead wires (O/W and B/W) at the CDI unit with the ignition switch in the "ON" position.

Is the voltage OK?

YES	Go to Step 3.
NO	<ul style="list-style-type: none"> <li>• Faulty ignition switch.</li> <li>• Faulty remote engine stop switch.</li> <li>• Faulty engine stop switch.</li> <li>• Broken wiring harness or poor connection of related circuit couplers.</li> </ul>

**Step 3**

1) Measure the ignition coil primary peak voltage. (☞6-20)

*NOTE:*

*This inspection method is applicable only with the multi-circuit tester and the peak volt adaptor.*

Is the peak voltage OK?

YES	Go to Step 4.
NO	Go to Step 5.

**Step 4**

1) Inspect the spark plug. (☞2-7)

Is the spark plug OK?

YES	Go to Step 6.
NO	Faulty spark plug.

**Step 5**

1) Inspect the parking brake switch. (☞6-23)

Is the parking brake switch OK?

YES	Go to Step 6.
NO	Faulty parking brake switch.

**Step 6**

1) Inspect the ignition coil. (☞6-21)

Is the ignition coil OK?

YES	Go to Step 7.
NO	<ul style="list-style-type: none"> <li>• Poor connection of the ignition coil.</li> <li>• Faulty ignition coil.</li> </ul>

**Step 7**

1) Measure the pick-up coil peak voltage and resistance. (☞6-21 to -22)

*NOTE:*

*The pick-up coil peak voltage inspection is applicable only with the multi-circuit tester and peak volt adaptor.*

Is the peak voltage and resistance OK?

YES	<ul style="list-style-type: none"> <li>• Faulty CDI unit.</li> <li>• Poor connection of generator coupler.</li> <li>• Open circuit in wiring harness.</li> </ul>
NO	Faulty pick-up coil.

## INSPECTION

### IGNITION COIL PRIMARY PEAK VOLTAGE

- Disconnect the spark plug cap.
- Connect a new spark plug ① to spark plug cap and ground it to the cylinder head.

#### NOTE:

Make sure that the spark plug cap and spark plug are connected properly and the battery is fully-charged.

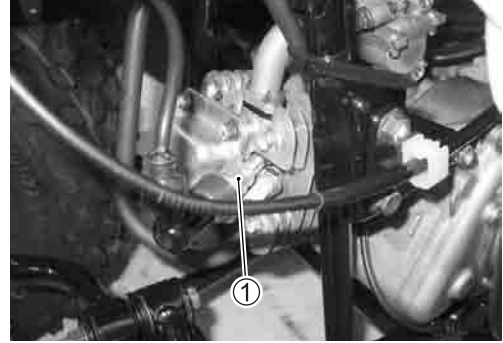

Measure ignition coil primary peak voltage with the multi-circuit tester in the following procedure.

- Connect the multi-circuit tester with the peak voltage adaptor as follows.

⊕ Probe: Black/White lead wire or ground

⊖ Probe: Black lead wire

#### NOTE:

Do not disconnect the ignition coil primary wires.

 **09900-25008: Multi-circuit tester set**

#### CAUTION

**When using the multi-circuit tester and peak volt adaptor, refer to the appropriate instruction manual.**

- Turn the ignition switch to the "ON" position.
- Press the starter button and allow the engine to crank for a few seconds, and then measure the ignition coil primary peak voltage.
- Repeat the above procedure a few times and measure the highest ignition coil primary peak voltage.

 **Tester knob indication: Voltage (---)**

 **Ignition coil primary peak voltage: 150 V and more**

#### WARNING

**While testing, do not touch the tester probes and spark plug to prevent receiving an electric shock.**

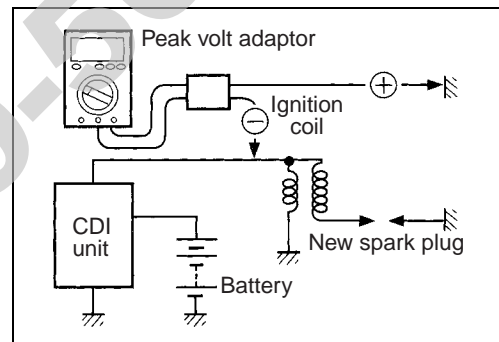
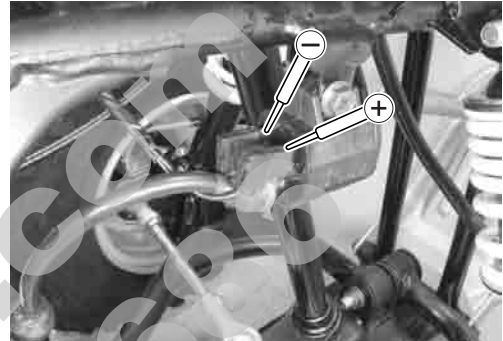

If the voltage is lower than the standard values, inspect the ignition coil. (ⓘ 6-21)

**IGNITION COIL RESISTANCE**

- Disconnect the ignition coil lead wires and spark plug cap, and remove the ignition coil.

Measure the ignition coil resistance in both the primary and secondary windings with the multi-circuit tester. If the resistance is not within the standard range, replace the ignition coil.



**TOOL** 09900-25008: Multi-circuit tester set

**TESTER** Tester knob indication: Resistance ( $\Omega$ )

**DATA** Ignition coil resistance

Primary : 0.1 – 0.7  $\Omega$  (Terminal – Terminal)

Secondary : 14 – 20 k $\Omega$  (Spark plug cap – Terminal)

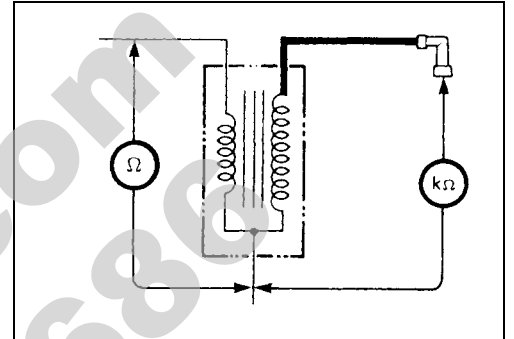
**PICK-UP COIL PEAK VOLTAGE**

- Remove the seat. (5-4)

**NOTE:**

*Make sure all of the couplers are connected properly.*

- Disconnect the CDI unit coupler ①.

Measure the pick-up coil peak voltage in the following procedure.

- Connect the multi-circuit tester with the peak volt adaptor as follows.

Pick-up coil: ⊕ Probe...Brown lead wire

⊖ Probe...Black/White lead wire or ground

**TOOL** 09900-25008: Multi-circuit tester set

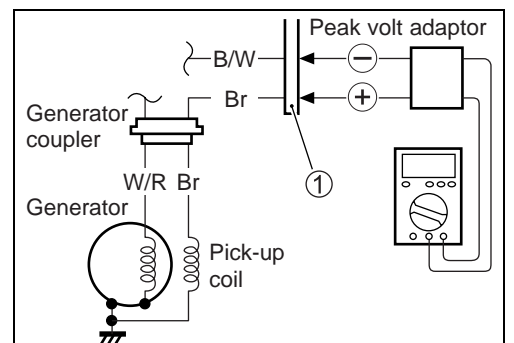
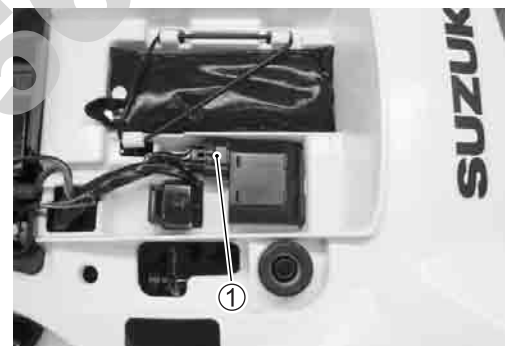
**CAUTION**

**When using the multi-circuit tester and peak volt adaptor, refer to the appropriate instruction manual.**

- Turn the ignition switch to the "ON" position.
- Press the starter button and allow the engine to turn for a few seconds, and then measure the pick-up coil peak voltage.

- Repeat the above procedure a few times and measure the highest pick-up coil peak voltage.

 **Tester knob indication: Voltage (---)**

**DATA** **Pick-up coil peak voltage: 1.5 V and more**

If the peak voltage measured on the CDI unit coupler is lower than the standard value, measure the peak voltage on the generator coupler as follows.

- Remove the left frame cover. (☞ 5-4)
- Disconnect the generator coupler ② and connect the multi-circuit tester with the peak volt adaptor as follows.

Pick-up coil: ⊕ Probe...Brown lead wire  
⊖ Probe...Ground

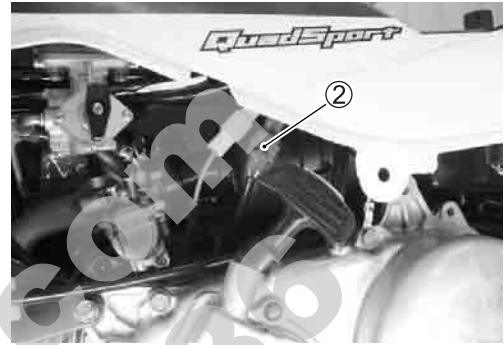

Measure the pick-up coil peak voltage in the same manner as on the CDI unit coupler.

 **Tester knob indication: Voltage (---)**

**DATA** **Pick-up coil peak voltage: 1.5 V and more**

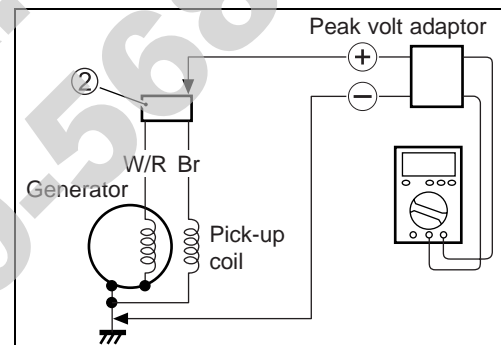

If the peak voltage on the generator coupler is within the specification, but on the CDI unit coupler is not within specification, replace the wiring harness with a new one. If both peak voltages are not within specification, replace the generator coil with a new one.

### PICK-UP COIL RESISTANCE

- Remove the left frame cover. (☞ 5-4)
- Disconnect the generator coupler ①.

Measure the resistance with the multi-circuit tester. If the resistance is not within the standard range, replace the generator coil.

 **09900-25008: Multi-circuit tester set**

 **Tester knob indication: Resistance (Ω)**

**DATA** **Pick-up coil resistance: 150 – 230 Ω (Brown – Ground)**

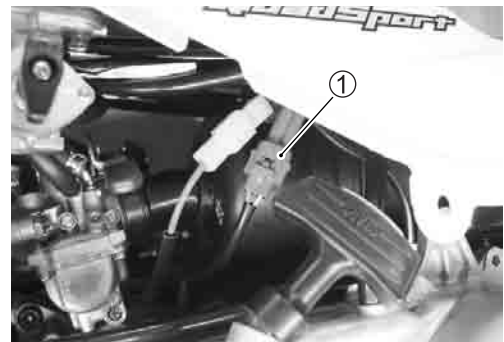

## SWITCHES

Measure each switch for continuity using a multi-circuit tester. If any abnormality is found, replace the respective switch assemblies with new ones.

 **09900-25008: Multi-circuit tester set**

 **Tester knob indication: Continuity test (•))**

### IGNITION SWITCH

Position \ Color	B/Y	B/W	R	O
OFF	○	○		
ON			○	○

### PARKING BRAKE SWITCH

Position \ Color	O	W/B
OFF		
ON	○	○

### ENGINE STOP SWITCH

Position \ Color	O/G	O/W
OFF		
RUN	○	○

### REMOTE ENGINE STOP SWITCH

Position \ Color	O	O/G
SECEDE		
SET	○	○

### STARTER BUTTON

Position \ Color	B/W	Y/G
•		
PUSH	○	○

### WIRE COLOR

O : Orange  
 R : Red  
 B/W : Black with White tracer  
 B/Y : Black with Yellow tracer  
 O/G : Orange with Green tracer  
 O/W : Orange with White tracer  
 W/B : White with Black tracer  
 Y/G : Yellow with Green tracer

PartSharkey.com  
877-999-5866



## BATTERY

### SPECIFICATIONS

Type designation	YTX5L-BS
Capacity	12 V, 14.4 kC (4 Ah)/10 HR

- |                        |                                |
|------------------------|--------------------------------|
| ① Upper cover breather | ⑤ Terminal                     |
| ② Cathode plates       | ⑥ Safety valve                 |
| ③ Stopper              | ⑦ Anode plates                 |
| ④ Filter               | ⑧ Separator (Fiberglass plate) |

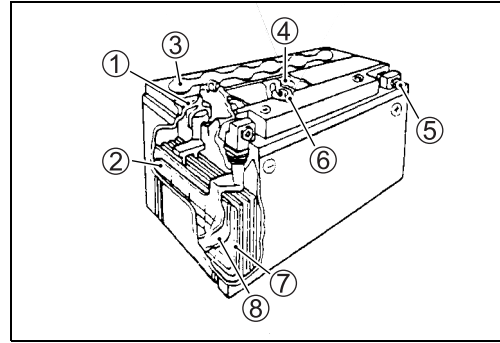

### INITIAL CHARGING

#### Filling electrolyte

- Remove the aluminum tape ① sealing the battery electrolyte filler holes (A).

#### NOTE:

When filling electrolyte, the battery must be removed from the vehicle and must be put on the level ground.

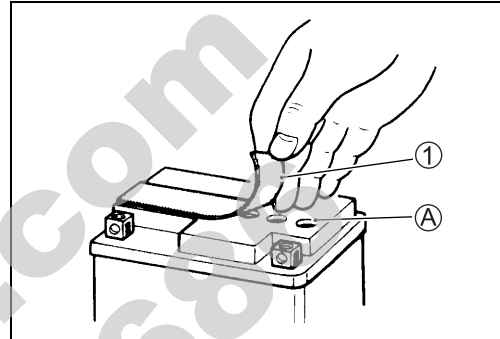

- Remove the caps ②.

#### NOTE:

- \* After filling the electrolyte completely, use the removed cap ② as sealing caps of battery-filler holes.
- \* Do not remove or pierce the sealed areas ③ of the electrolyte container.

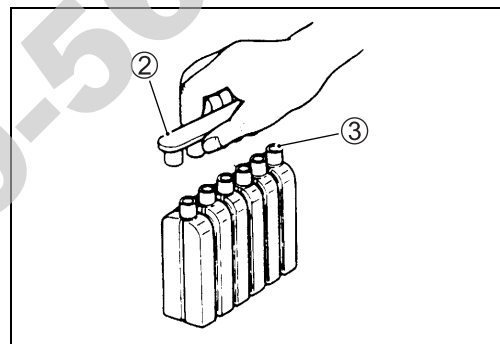

- Insert the nozzles of the electrolyte container ④ into the battery's electrolyte filler holes, holding the container firmly so that it does not fall. Take precaution not to allow any of the fluid to spill.

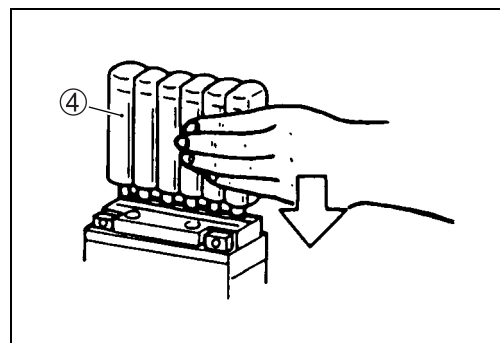

- Make sure air bubbles ⑤ are coming up in each electrolyte container, and leave in this position for about more than 20 minutes.

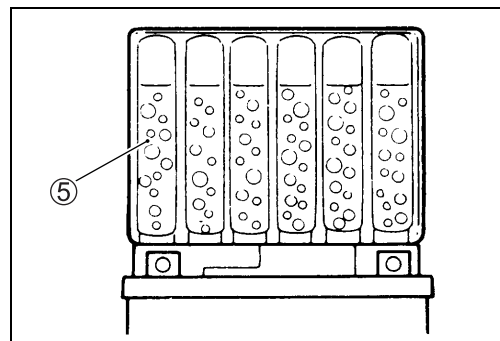

**NOTE:**

If no air bubbles are coming up from a filler port, tap the bottom of the electrolyte container two or three times.

Never remove the container from the battery.

- After confirming that the electrolyte has entered the battery completely, remove the electrolyte containers from the battery. Wait for about 20 minutes.

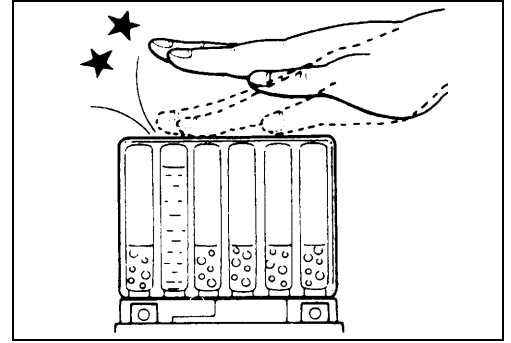

- Insert the caps ⑥ into the filler holes, pressing in firmly so that the top of the caps do not protrude above the upper surface of the battery's top cover.

**CAUTION**

- \* Never use anything except the specified battery.
- \* Once the caps have been installed to the battery, do not remove the caps.
- \* Do not tap the caps with a tool such as hammer when installing them.

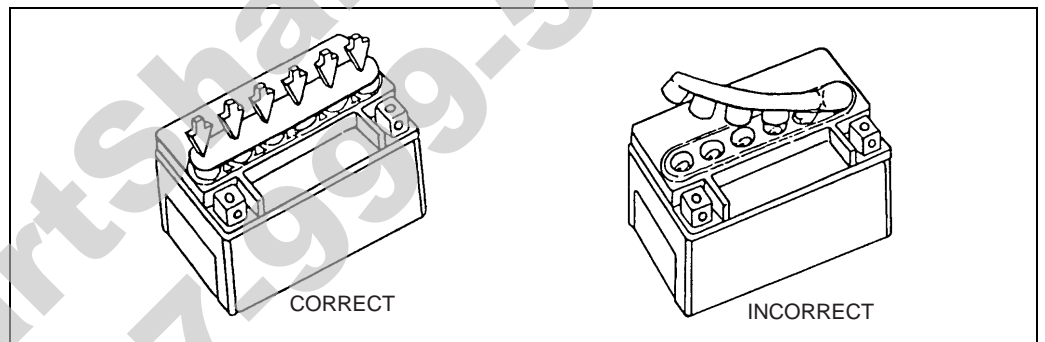
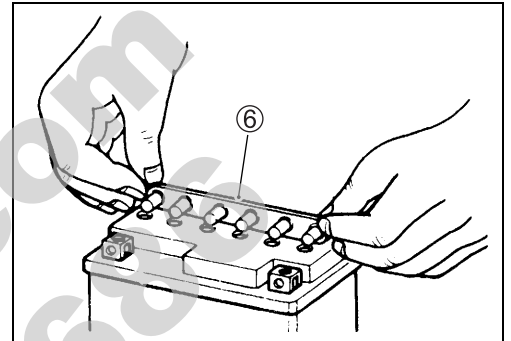

For initial charging, use the charger specially designed for MF battery.

**CAUTION**

- \* For charging the battery, make sure to use the charger specially designed for MF battery. Otherwise, the battery may be overcharged resulting in shortened service life.
- \* Do not remove the cap during charging.
- \* Position the battery with the cap facing upward during charging.

## SERVICING

Visually inspect the surface of the battery container. If any signs of cracking or electrolyte leakage from the sides of the battery have occurred, replace the battery with a new one. If the battery terminals are found to be coated with rust or an acidic white powdery substance, clean the battery terminals with sandpaper.

## RECHARGING OPERATION

- Using the multi-circuit tester, check the battery voltage. If the voltage reading is 12.0 V (DC) and less, recharge the battery with a battery charger.

- Ⓐ Charging period
- Ⓑ Stop charging

### CAUTION

- \* When recharging the battery, remove the battery from the vehicle.
- \* Do not remove the caps on the battery top while recharging.

Recharging time: 0.5 A for 5 to 10 hours or 5 A for 30 minutes

### CAUTION

Be careful not to permit the charging current to exceed 5 A at any time.

- After recharging, wait for 30 minutes and more and check the battery voltage with a multi-circuit tester.
- If the battery voltage is the 12.5 V and less, recharge the battery again.
- If battery voltage is still 12.5 V and less, after recharging, replace the battery with a new one.
- When the vehicle is not used for a long period, check the battery every 1 month to prevent the battery discharge.

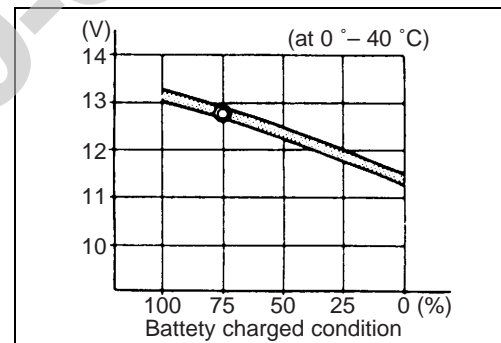
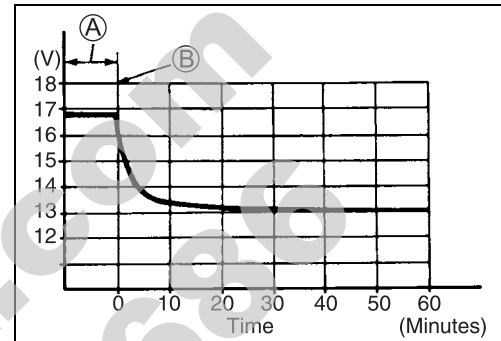

# SERVICING INFORMATION

## CONTENTS

<b>TROUBLESHOOTING</b> .....	7- 2
<b>ENGINE</b> .....	7- 2
<b>CARBURETOR</b> .....	7- 6
<b>CHASSIS</b> .....	7- 7
<b>BRAKES</b> .....	7- 9
<b>ELECTRICAL</b> .....	7-10
<b>BATTERY</b> .....	7-12
<b>WIRING DIAGRAM</b> .....	7-13
<b>WIRING HARNESS, CABLE AND HOSE ROUTING</b> .....	7-14
<b>WIRING HARNESS ROUTING</b> .....	7-14
<b>CABLE ROUTING</b> .....	7-16
<b>FUEL HOSE PIPING</b> .....	7-17
<b>CARBURETOR AND CVT CASE HOSE ROUTING</b> .....	7-18
<b>HANDLEBARS AND HANDLEBAR PAD INSTALLATION</b> .....	7-19
<b>HEAT SHIELD INSTALLATION</b> .....	7-20
<b>SPECIAL TOOLS</b> .....	7-21
<b>TIGHTENING TORQUE</b> .....	7-23
<b>ENGINE</b> .....	7-23
<b>FUEL</b> .....	7-23
<b>CHASSIS</b> .....	7-24
<b>TIGHTENING TORQUE CHART</b> .....	7-25
<b>SERVICE DATA</b> .....	7-26

## TROUBLESHOOTING

### ENGINE

#### ENGINE WILL NOT START OR IS HARD TO START

##### Symptom, possible causes and remedy

- |  |                         |
|--|-------------------------|
| 1) Compression too low                                   |                         |
| • Valve clearance out of adjustment.                     | Adjust.                 |
| • Worn valve guides or poor seating of valves.           | Repair or replace.      |
| • Mistimed valves.                                       | Adjust.                 |
| • Excessively worn piston rings.                         | Replace.                |
| • Worn-down cylinder bore.                               | Replace.                |
| • Starter motor cranks too slowly.                       | See electrical section. |
| • Poor seating of spark plug.                            | Retighten.              |
| • Gas leaks from the joint in cylinder or cylinder head. | Repair or replace.      |
| • Loose spark plug.                                      | Tighten.                |
| • Broken, cracked or damaged piston.                     | Replace.                |
| 2) Plug not sparking                                     |                         |
| • Damaged spark plug.                                    | Replace.                |
| • Damaged spark plug cap.                                | Replace.                |
| • Fouled spark plug.                                     | Clean or replace.       |
| • Wet spark plug.  | Clean and dry.          |
| • Defective CDI unit.                                    | Replace.                |
| • Defective ignition coil.                               | Replace.                |
| • Open-circuited wiring connections.                     | Repair or replace.      |
| • Defective generator coil.                              | Replace.                |
| 3) No fuel reaching the carburetor                       |                         |
| • Clogged fuel hose.                                     | Clean or replace.       |
| • Clogged or defective fuel valve.                       | Clean or replace.       |
| • Defective carburetor needle valve.                     | Replace.                |
| • Clogged fuel filter.                                   | Clean or replace.       |

#### ENGINE STALLS OFTEN

##### Symptom, possible causes and remedy

- |                                      |          |
|--------------------------------------|----------|
| • Fouled spark plug.                 | Clean.   |
| • Defective CDI unit.                | Replace. |
| • Defective ignition coil.           | Replace. |
| • Clogged fuel hose.                 | Clean.   |
| • Clogged carburetor jets.           | Clean.   |
| • Clogged exhaust pipe.              | Clean.   |
| • Damaged cylinder head gasket.      | Replace. |
| • Valve clearance out of adjustment. | Adjust.  |

**NOISY ENGINE****Symptom, possible causes and remedy**

- 1) Excessive valve chatter
  - Too large valve clearance. Adjust.
  - Weakened or broken valve springs. Replace.
  - Worn rocker arm or cam surface. Replace.
- 2) Noise seems to come from piston
  - Worn down piston or cylinder. Replace.
  - Combustion chamber fouled with carbon. Clean.
  - Worn piston pin or piston pin bore. Replace.
  - Worn piston rings or ring grooves. Replace.
- 3) Noise seems to come from clutch
  - Weak clutch shoe spring. Replace.
- 4) Noise seems to come from crankshaft
  - Rattling bearings due to wear. Replace.
  - Worn and burnt journal bearings. Replace.
  - Too large thrust clearance. Replace bearing retainer.
- 5) Noise seems to come from the movable drive and driven face
  - Worn or slipping drive belt. Replace.
  - Worn rollers in movable drive face. Replace.

**CLUTCH SLIPS****Symptom, possible causes and remedy**

- Worn or damaged clutch shoe. Replace.
- Worn clutch housing. Replace.

**ENGINE IDLES POORLY****Symptom, possible causes and remedy**

- Valve clearance out of adjustment. Adjust.
- Poor seating of valves. Replace or repair.
- Defective valve guides. Replace.
- Worn down camshaft. Replace.
- Worn cylinder. Replace.
- Worn piston rings. Replace.
- Stiff piston rings. Replace.
- Excessive spark plug gap. Adjust or replace.
- Defective CDI unit. Replace.
- Defective ignition coil. Replace.
- Defective generator coil. Replace.
- Incorrect float chamber fuel level. Adjust float height.
- Clogged carburetor jet. Clean.

### ENGINE RUNS POORLY IN HIGH SPEED RANGE

#### Symptom, possible causes and remedy

- |  |                      |
|--|----------------------|
| • Weakened valve springs.  | Replace.             |
| • Worn camshaft.   | Replace.             |
| • Valve timing out of adjustment.  | Adjust.              |
| • Too narrow spark plug gap.   | Adjust.              |
| • Ignition not advanced sufficiently due to poorly working timing advance circuit. | Replace.             |
| • Defective CDI unit.  | Replace.             |
| • Defective ignition coil.   | Replace.             |
| • Defective generator coil.  | Replace.             |
| • Low float chamber fuel level.  | Adjust float height. |
| • Clogged fuel hose, resulting in inadequate fuel supply to the carburetor.        | Clean and prime.     |
| • Clogged fuel valve.  | Clean.               |
| • Clogged air cleaner element.   | Clean or replace.    |
| • Sucking air from carburetor joint.   | Repair or replace.   |

PartShark.com  
877-999-5686



**ENGINE LACKS POWER****Symptom, possible causes and remedy**

- |   |                       |
|---|-----------------------|
| • Loss of valve clearance.                    | Adjust.               |
| • Weakened valve springs.                     | Replace.              |
| • Valve timing out of adjustment.             | Adjust.               |
| • Worn piston rings or cylinder.              | Replace.              |
| • Poor seating of valves.                     | Repair.               |
| • Fouled spark plug.                          | Clean or replace.     |
| • Incorrect spark plug.                       | Adjust or replace.    |
| • Clogged carburetor jet.                     | Clean.                |
| • Insufficient spark plug gap.                | Regap or replace.     |
| • Air leakage from intake pipe.               | Tighten or replace.   |
| • Incorrect float chamber fuel level.         | Adjust float height.  |
| • Clogged air cleaner element.                | Replace.              |
| • Sucking air from carburetor or vacuum hose. | Retighten or replace. |
| • Too much engine oil.                        | Drain out excess oil. |

**ENGINE OVERHEATS****Symptom, possible causes and remedy**

- |   |                      |
|---|----------------------|
| • Heavy carbon deposit on piston head.                  | Clean.               |
| • Not enough oil in the engine.                         | Add oil.             |
| • Use of incorrect engine oil.                          | Change.              |
| • Low float chamber fuel level.                         | Adjust float height. |
| • Air leakage from intake pipe.                         | Tighten or replace.  |
| • Incorrect spark plug.                                 | Change.              |
| • Clogged exhaust pipe/muffler.                         | Clean or replace.    |
| • Ignition timing too advanced due to defective timing. | Replace.             |

**DIRTY OR HEAVY EXHAUST SMOKE****Symptom, possible causes and remedy**

- |                                      |                   |
|--------------------------------------|-------------------|
| • Too much engine oil in the engine. | Drain excess oil. |
| • Worn piston rings or cylinder.     | Replace.          |
| • Worn valve guides.                 | Replace.          |
| • Scored or scuffed cylinder wall.   | Replace.          |
| • Worn valves stems.                 | Replace.          |
| • Defective stem seal.               | Replace.          |
| • Worn oil ring side rail.           | Replace.          |

## CARBURETOR

### STARTING DIFFICULTY

#### Symptom, possible causes and remedy

- Clogged fuel pipe. Clean.
- Air leaking from joint between intake port and carburetor. Tighten or replace gasket.
- Air leaking from carburetor joint. Tighten or replace defective parts.
- Improperly working starter plunger. Adjust.

### IDLING OR LOW-SPEED TROUBLE

#### Symptom, possible causes and remedy

- Clogged or loose pilot jet. Clean or tighten.
- Air leaking from carburetor joint. Tighten, or replace defective part.
- Clogged pilot outlet port. Clean.
- Clogged bypass port. Clean.
- Starter plunger not fully closed. Adjust.

### MEDIUM OR HIGH-SPEED TROUBLE

#### Symptom, possible causes and remedy

- Clogged main jet. Clean.
- Clogged needle jet. Clean.
- Improperly working piston valve. Adjust.
- Clogged fuel filter. Clean or replace.

### OVERFLOW AND FUEL LEVEL FLUCTUATIONS

#### Symptom, possible causes and remedy

- Worn or damaged needle valve. Replace.
- Improperly working float. Adjust or replace.
- Foreign matter on the needle valve. Clean or replace with needle valve seat.
- Incorrect float chamber fuel level. Adjust float height.

## CHASSIS

### HEAVY STEERING

#### Symptom, possible causes and remedy

- Distorted steering shaft. Replace.
- Not enough pressure in tires. Adjust.
- Improper front wheel alignment. Adjust.
- Insufficiently lubricated. Lubricate.
- Linkage connections tending to seize. Repair or replace.
- Tie-rod ends tending to seize. Replace.

### WOBBLY HANDLEBAR

#### Symptom, possible causes and remedy

- Unequally inflated tires. Regulate.
- Loose front wheel hub nuts. Tighten.
- Damaged or worn front wheel hub bearings. Replace.
- Worn or loose tie-rod ends. Replace or tighten.
- Defective or incorrect front tires. Replace.
- Damaged or worn suspension arms and related bushings. Replace.
- Distorted front wheels. Replace.
- Loose chassis nuts and bolts. Tighten.

### STEERING PULLS TO ONE SIDE

#### Symptom, possible causes and remedy

- Unequally inflated tires. Regulate.
- Improper front wheel alignment. Adjust.
- Worn front wheel hub bearings. Replace.
- Distorted frame. Repair or replace.
- Defective shock absorber. Replace.

### SHOCKS FELT IN THE STEERING

#### Symptom, possible causes and remedy

- High tire pressure. Regulate.
- Worn steering linkage connection. Replace.
- Loose suspension system bolts. Tighten.

### TIRES RAPIDLY OR UNEVENLY WEAR

#### Symptom, possible causes and remedy

- Worn or loose front wheel hub bearings. Replace.
- Improper front wheel alignment. Adjust.

### STEERING TOO NOISY

#### Symptom, possible causes and remedy

- Loose nuts and bolts. Tighten.
- Damaged or worn front wheel hub bearings. Replace.
- Insufficiently lubricated. Lubricate.

**FRONT SUSPENSION TOO SOFT****Symptom, possible causes and remedy**

- Weakened spring of shock absorber. Replace.
- Shock absorber leaks oil. Replace.

**FRONT SUSPENSION TOO STIFF****Symptom, possible causes and remedy**

- Bent shock absorber shaft. Replace.
- Worn suspension arms and related bushing. Replace.

**NOISY FRONT SUSPENSION****Symptom, possible causes and remedy**

- Loose nuts or bolts on suspension. Retighten.
- Worn suspension arms and related bushings. Replace.

**WOBBLY REAR WHEEL****Symptom, possible causes and remedy**

- Distorted wheel rims. Replace.
- Damaged or worn rear axle housing bearings. Replace.
- Defective or incorrect tires. Replace.
- Defective rear axle. Replace.
- Loose nuts or bolts on rear suspension. Retighten.
- Loose rear wheel hub nuts. Tighten.
- Loosen rear axle housing mounting bolts. Tighten.
- Improper rear brake adjustment. Adjust.
- Rear shock absorber leaks oil. Replace.
- Damaged or worn rear swingarm and related bushings. Replace.

**REAR SUSPENSION TOO SOFT****Symptom, possible causes and remedy**

- Weakened spring of shock absorber. Replace.
- Leakage of oil from shock absorber. Replace.

**REAR SUSPENSION TOO STIFF****Symptom, possible causes and remedy**

- Bent shock absorber shaft. Replace.
- Worn swingarm and related bushings. Replace.

**NOISY REAR SUSPENSION****Symptom, possible causes and remedy**

- Loose nuts or bolts on rear suspension. Retighten.
- Worn swingarm. Replace.

## BRAKES

### INSUFFICIENT BRAKE POWER

#### Symptom, possible causes and remedy

- |  |                       |
|--|-----------------------|
| • Worn brake drum.                           | Replace.              |
| • Oil adhesion on friction surface of shoes. | Clean drum and shoes. |
| • Worn shoe linings.                         | Replace.              |
| • Too much play on brake lever.              | Adjust.               |

### BRAKE SQUEAKING

#### Symptom, possible causes and remedy

- |  |                                |
|--|--------------------------------|
| • Carbon adhesion on lining surface.               | Repair surface with sandpaper. |
| • Loose front wheel hub nut or rear wheel hub nut. | Tighten to specified torque.   |
| • Damaged wheel hub bearings.                      | Replace.                       |
| • Worn linings.                                    | Replace.                       |
| • Wrongly fixed spring.                            | Set correctly.                 |

### EXCESSIVE BRAKE LEVER STROKE

#### Symptom, possible causes and remedy

- |                         |                    |
|-------------------------|--------------------|
| • Worn brake lever cam. | Replace brake cam. |
|-------------------------|--------------------|

### BRAKE DRAGS

#### Symptom, possible causes and remedy

- |   |                      |
|---|----------------------|
| • Rusty part.                           | Clean and lubricate. |
| • Insufficient brake lever lubrication. | Lubricate.           |

PartShark.com  
877-999-5686

## ELECTRICAL

### NO SPARKING OR POOR SPARKING

#### Symptom, possible causes and remedy

- Defective CDI unit. Replace.
- Defective ignition coil. Replace.
- Defective spark plug. Replace.
- Defective generator coil. Replace.
- Loose connection of lead wire. Connect or tighten.
- Open-circuited wiring connections. Check and repair.

### SPARK PLUG SOON BECOMES FOULED WITH CARBON

#### Symptom, possible causes and remedy

- Mixture too rich. Adjust carburetor.
- Incorrect gasoline. Change.
- Dirty air cleaner element. Replace.
- Incorrect spark plug. Replace.

### SPARK PLUG BECOMES FOULED TOO SOON

#### Symptom, possible causes and remedy

- Worn piston rings. Replace.
- Worn piston or cylinder. Replace.
- Excessive clearance of valve stems in valve guides. Replace.
- Worn stem oil seal. Replace.

### SPARK PLUG ELECTRODES OVERHEAT OR BURN

#### Symptom, possible causes and remedy

- Too hot spark plug. Replace with cold type plug.
- Overheated the engine. Tune up.
- Loose spark plug. Retighten.
- Too lean mixture. Adjust carburetor.

### GENERATOR DOES NOT CHARGE

#### Symptom, possible causes and remedy

- Open- or short-circuited lead wires, or loose lead connections. Repair or replace or retighten.
- Short-circuited, grounded or open generator coil. Replace.
- Short-circuited or punctured regulator/rectifier. Replace.

### GENERATOR DOES CHARGE, BUT CHARGING RATE IS BELOW THE SPECIFICATION

#### Symptom, possible causes and remedy

- Lead wires tend to get short- or open-circuited or loosely connected at terminals. Repair or retighten.
- Grounded or open-circuited generator coil. Replace.
- Defective regulator/rectifier. Replace.
- Defective cell plates in the battery. Replace the battery.

### GENERATOR OVERCHARGES

#### Symptom, possible causes and remedy

- Internal short-circuit in the battery. Replace the battery.
- Damaged or defective regulator/rectifier. Replace.
- Poorly grounded regulator/rectifier. Clean and tighten ground connection.

**UNSTABLE CHARGING****Symptom, possible causes and remedy**

- Lead wire insulation frayed due to vibration, resulting in intermittent short-circuiting. Repair or replace.
- Internally short-circuited generator. Replace.
- Defective regulator/rectifier. Replace.

**START BUTTON IS NOT EFFECTIVE****Symptom, possible causes and remedy**

- Run down battery. Repair or replace.
- Defective switch contacts. Replace.
- Brushes not seating properly on starter motor commutator. Repair or replace.
- Defective starter relay. Replace.
- Defective main fuse. Replace.

PartShark.com  
877-999-5686



## BATTERY

### “SULFATION”, ACIDIC WHITE POWDERY SUBSTANCE OR SPOTS ON SURFACE OF CELL PLATES

#### Symptom, possible causes and remedy

- Cracked battery case. Replace the battery.
- Battery has been left in a run-down condition for a long time. Replace the battery.

### BATTERY RUNS DOWN QUICKLY

#### Symptom, possible causes and remedy

- Trouble in charging system. Check the generator, regulator/rectifier and circuit connections and make necessary adjustments to obtain specified charging operation.
- Cell plates have lost much of their active material as a result of overcharging. Replace the battery and correct the charging system.
- Internal short-circuit in the battery. Replace the battery.
- Too low battery voltage. Recharge the battery fully.
- Too old battery. Replace the battery.

### BATTERY “SULFATION”

#### Symptom, possible causes and remedy

- Incorrect charging rate. Replace the battery.  
(When not in use, battery should be checked at least once a month to avoid sulfation.)
- The battery was left unused in a cold climate for too long. Replace the battery if badly sulfated.

PartShark.com  
877-999-5686

# WIRING DIAGRAM

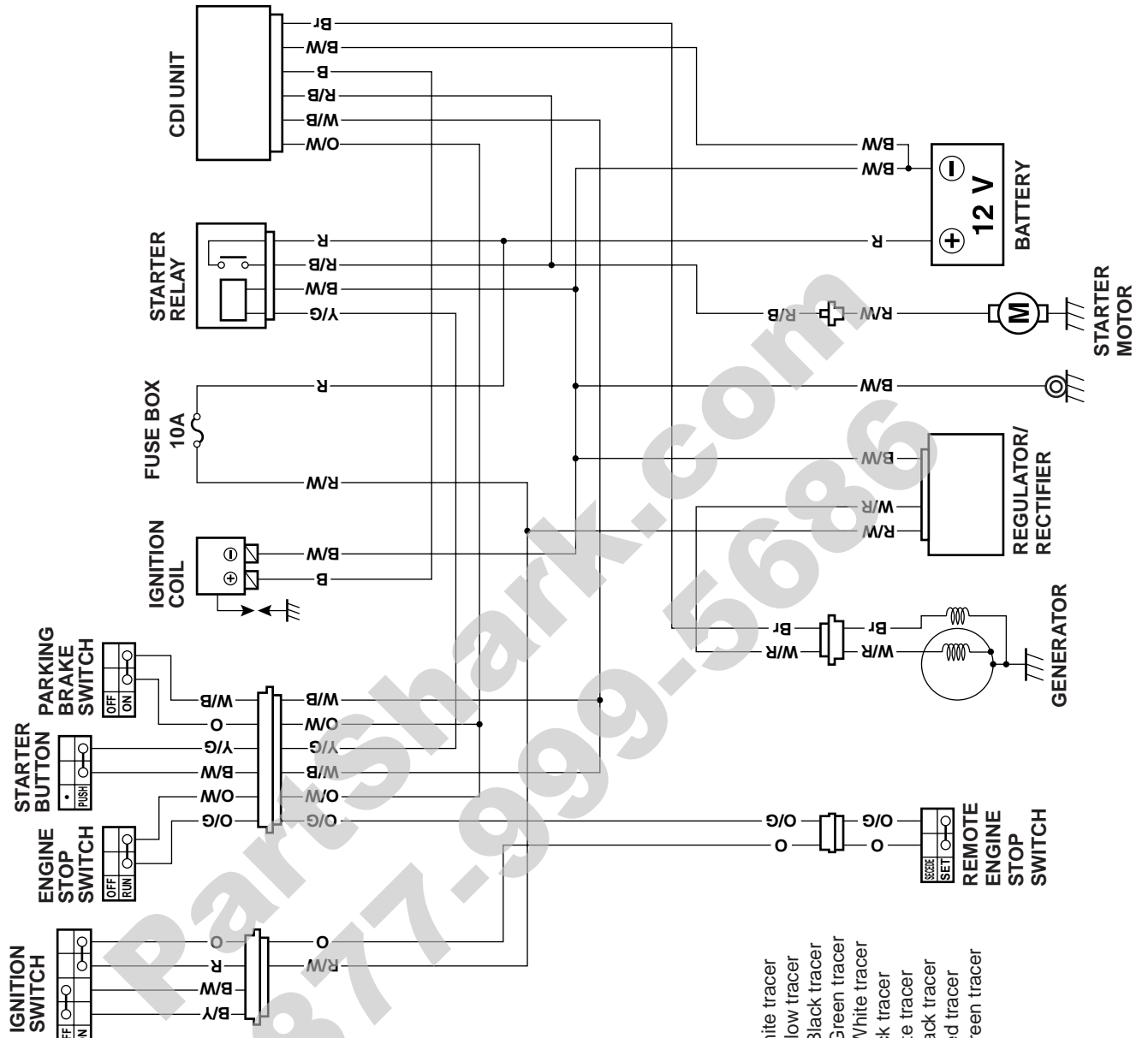

## WIRE COLOR

- B : Black
- Br : Brown
- O : Orange
- R : Red
- BW : Black with White tracer
- B/Y : Black with Yellow tracer
- O/B : Orange with Black tracer
- O/G : Orange with Green tracer
- O/W : Orange with White tracer
- R/B : Red with Black tracer
- R/W : Red with White tracer
- W/B : White with Black tracer
- W/R : White with Red tracer
- Y/G : Yellow with Green tracer

# WIRING HARNESS, CABLE AND HOSE ROUTING

## WIRING HARNESS ROUTING

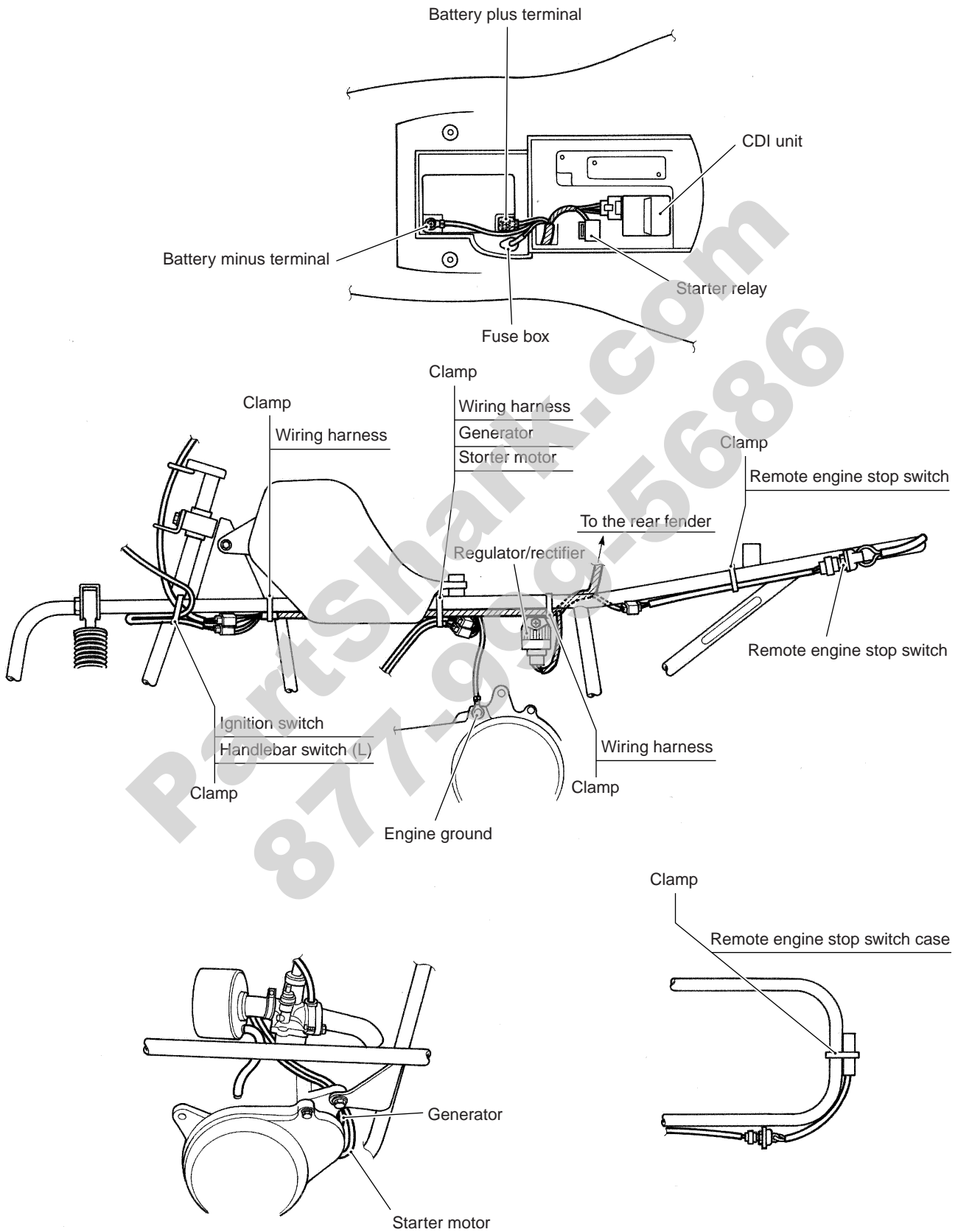

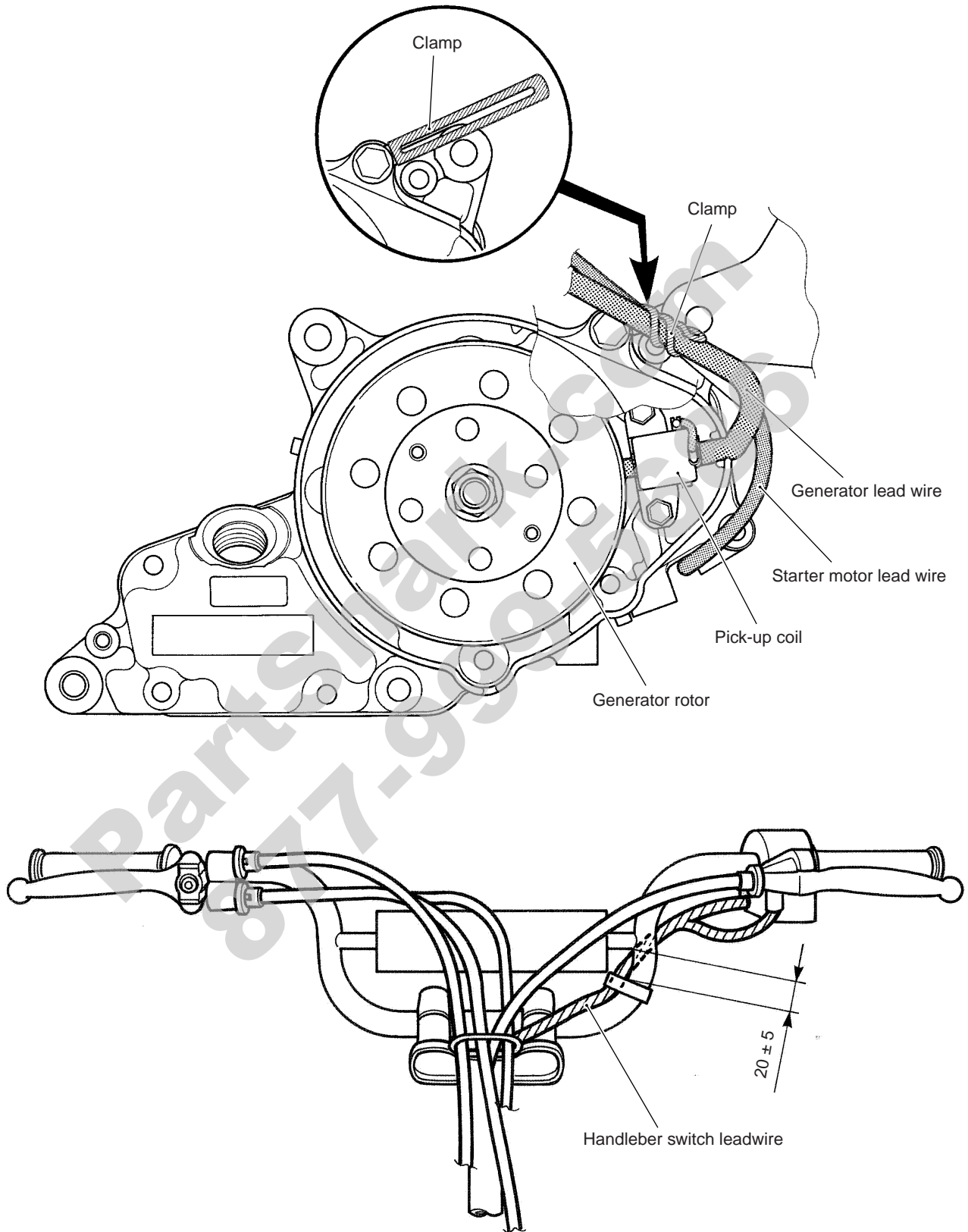

# CABLE ROUTING

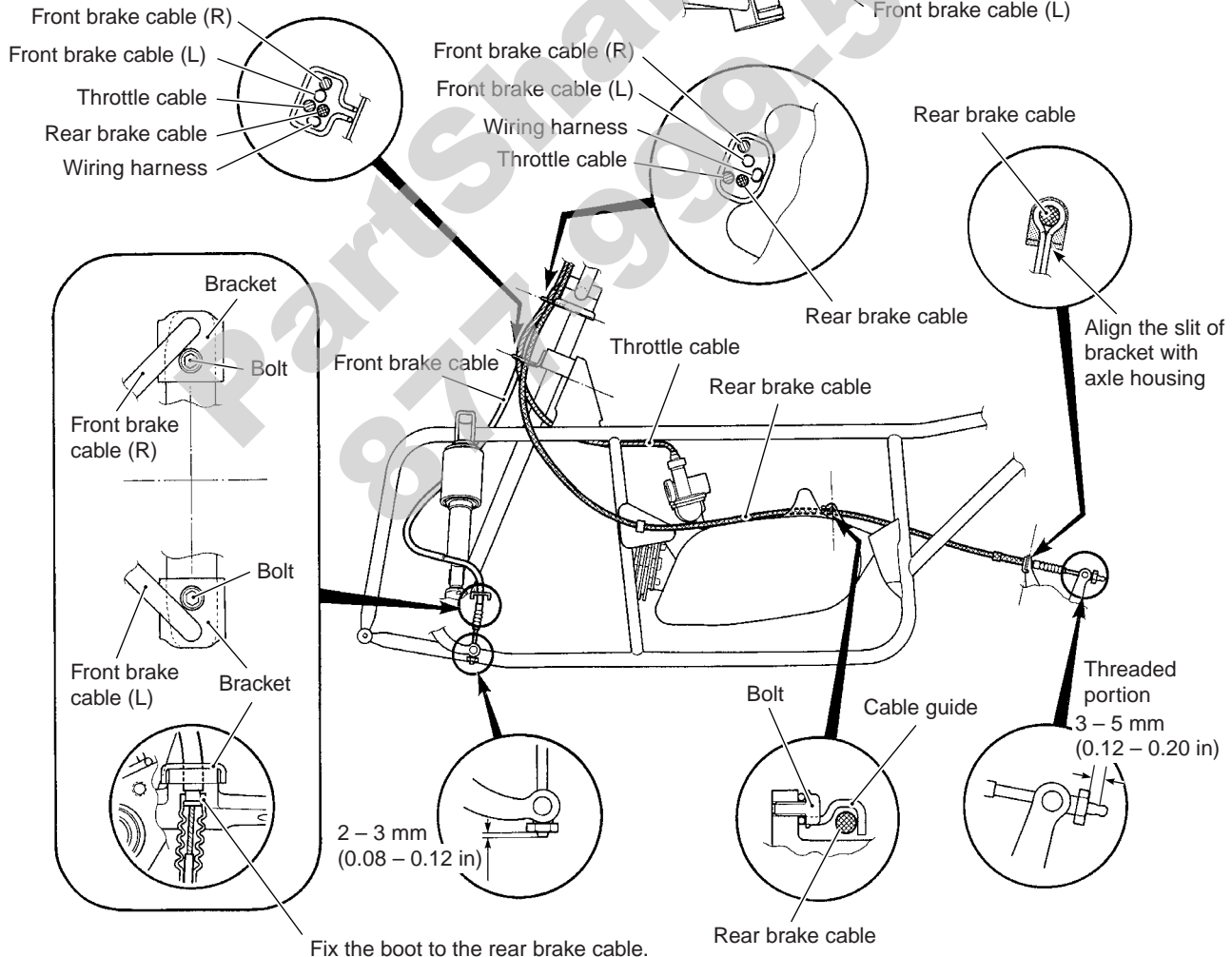
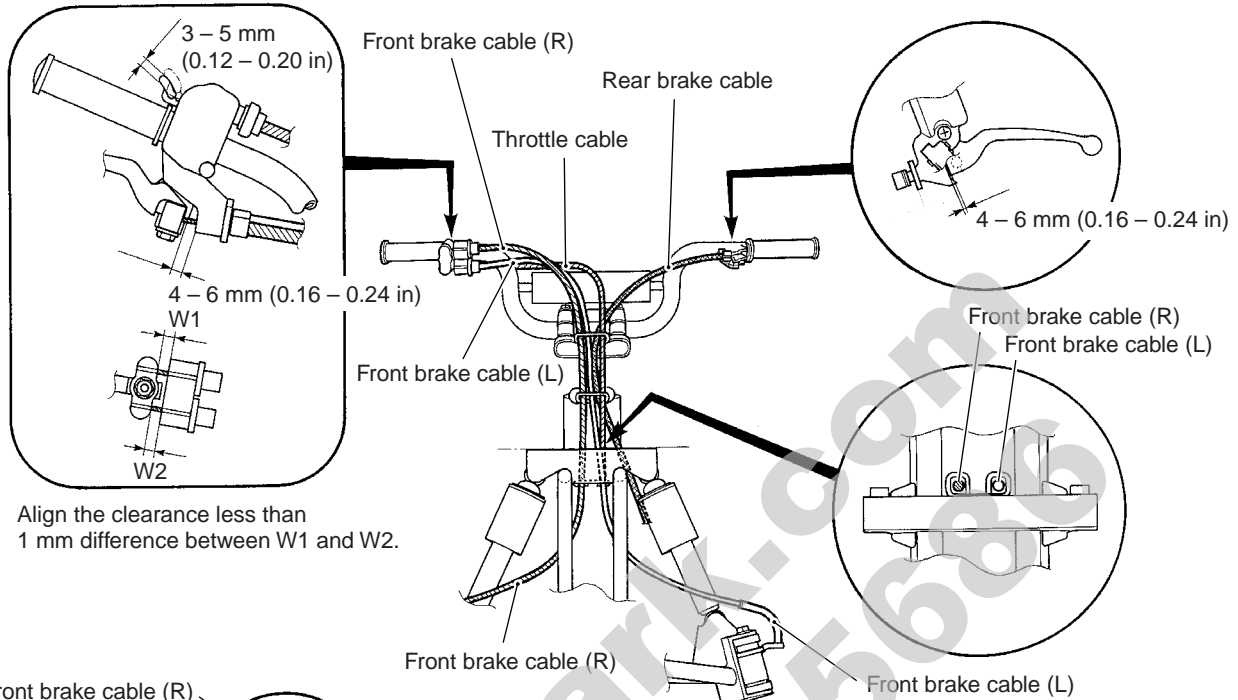

## FUEL HOSE PIPING

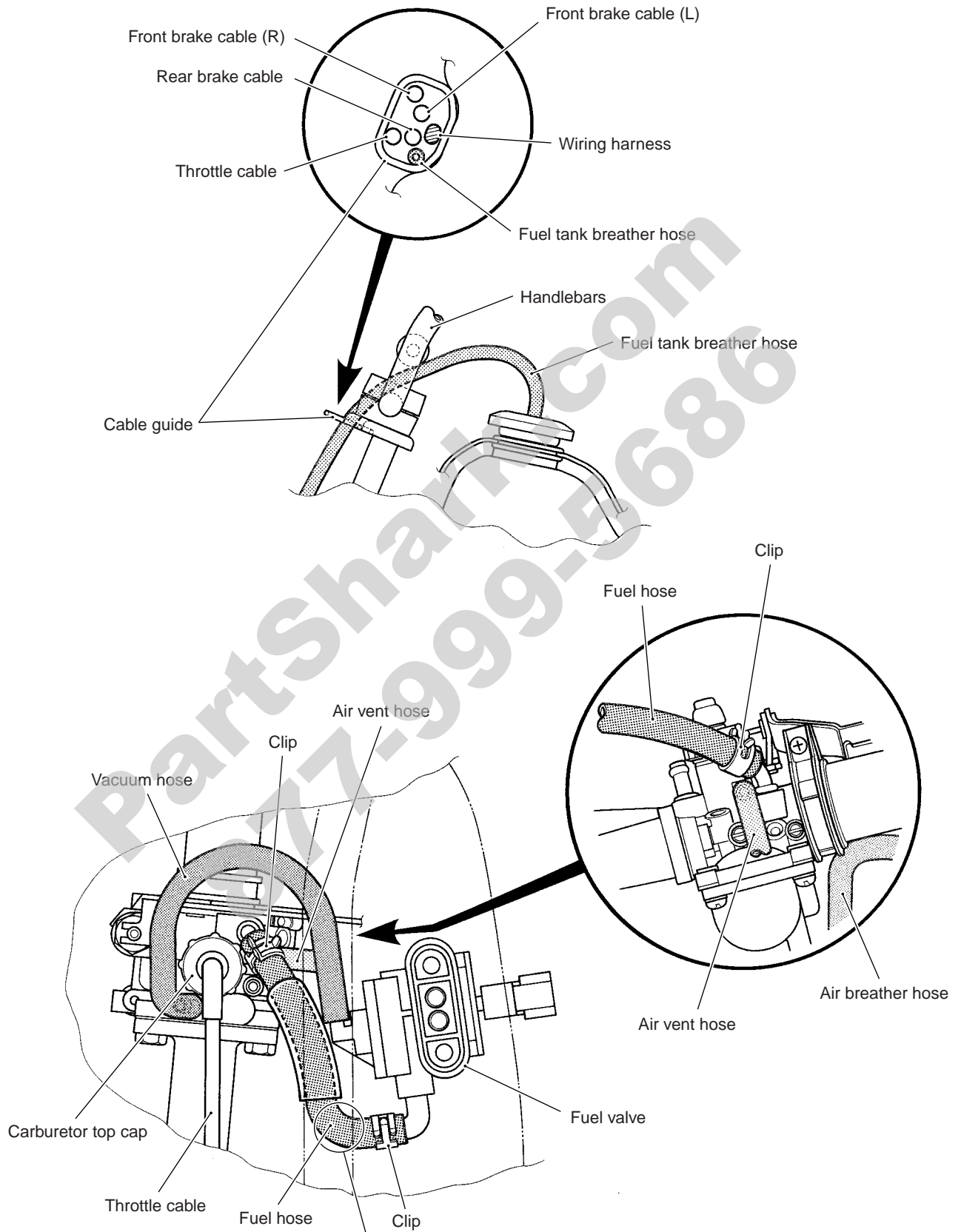

Install the rounded side of fuel hose to the fuel valve.

## CARBURETOR AND CVT CASE HOSE ROUTING

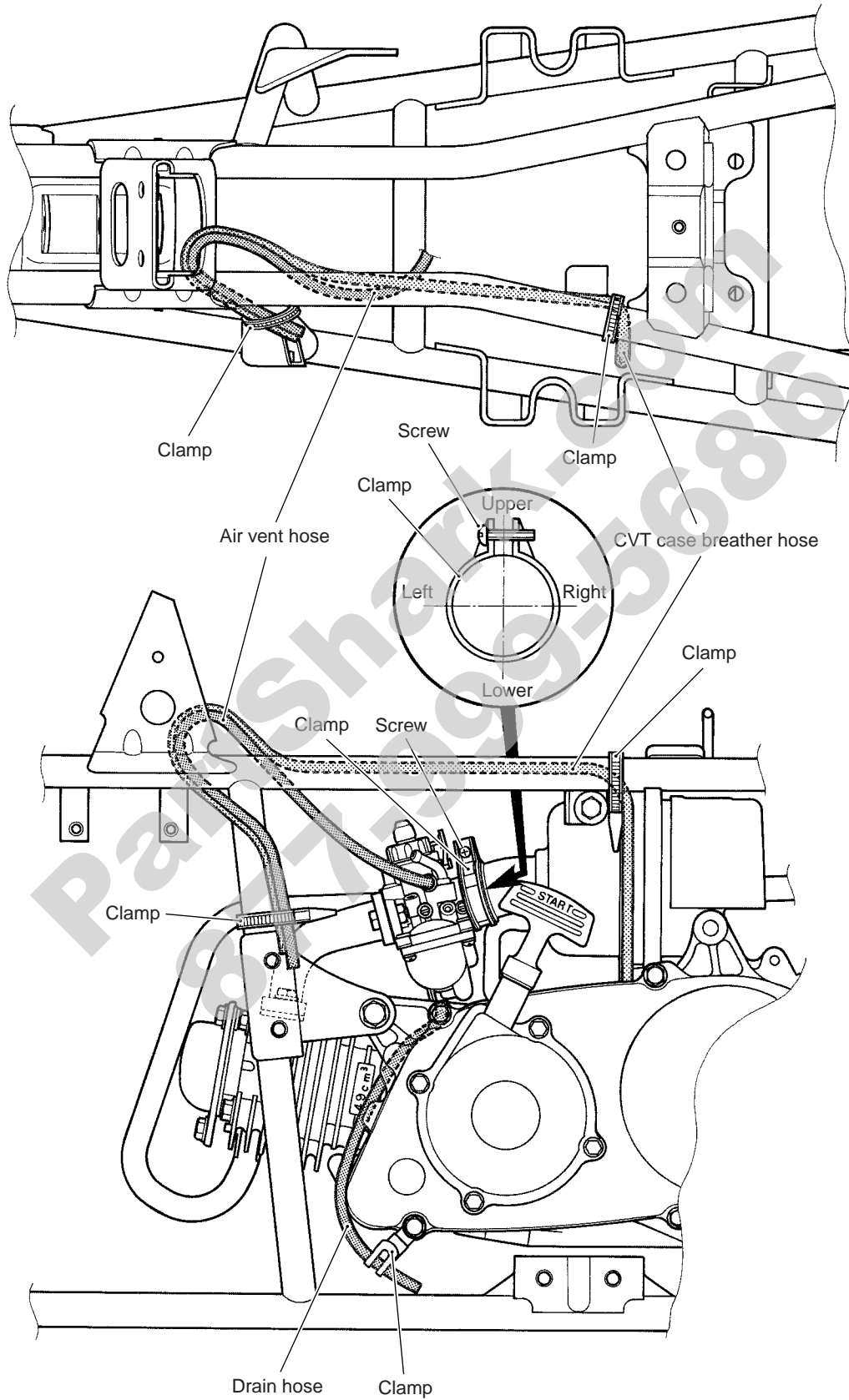



# HANDLEBARS AND HANDLEBAR PAD INSTALLATION

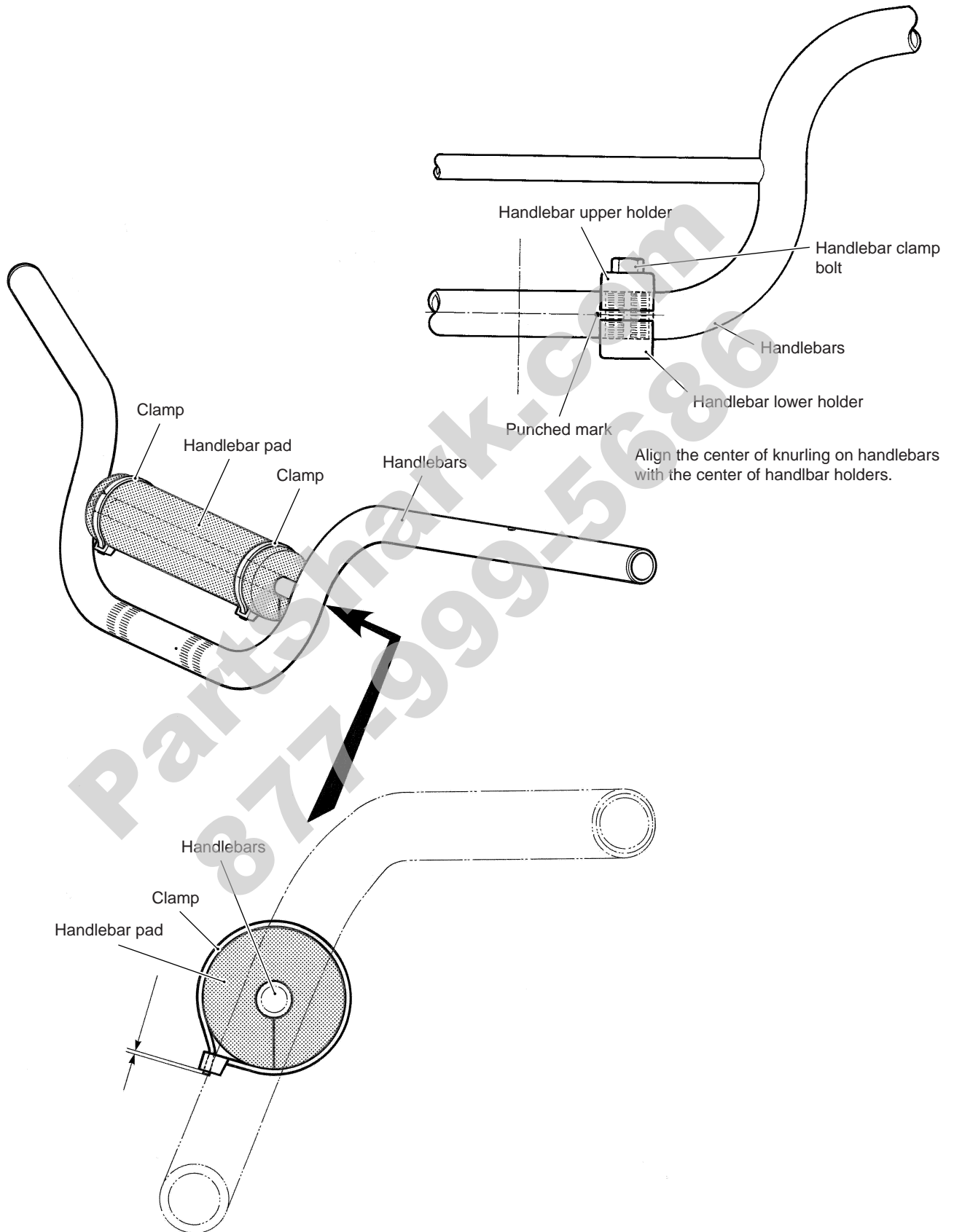

# HEAT SHIELD INSTALLATION

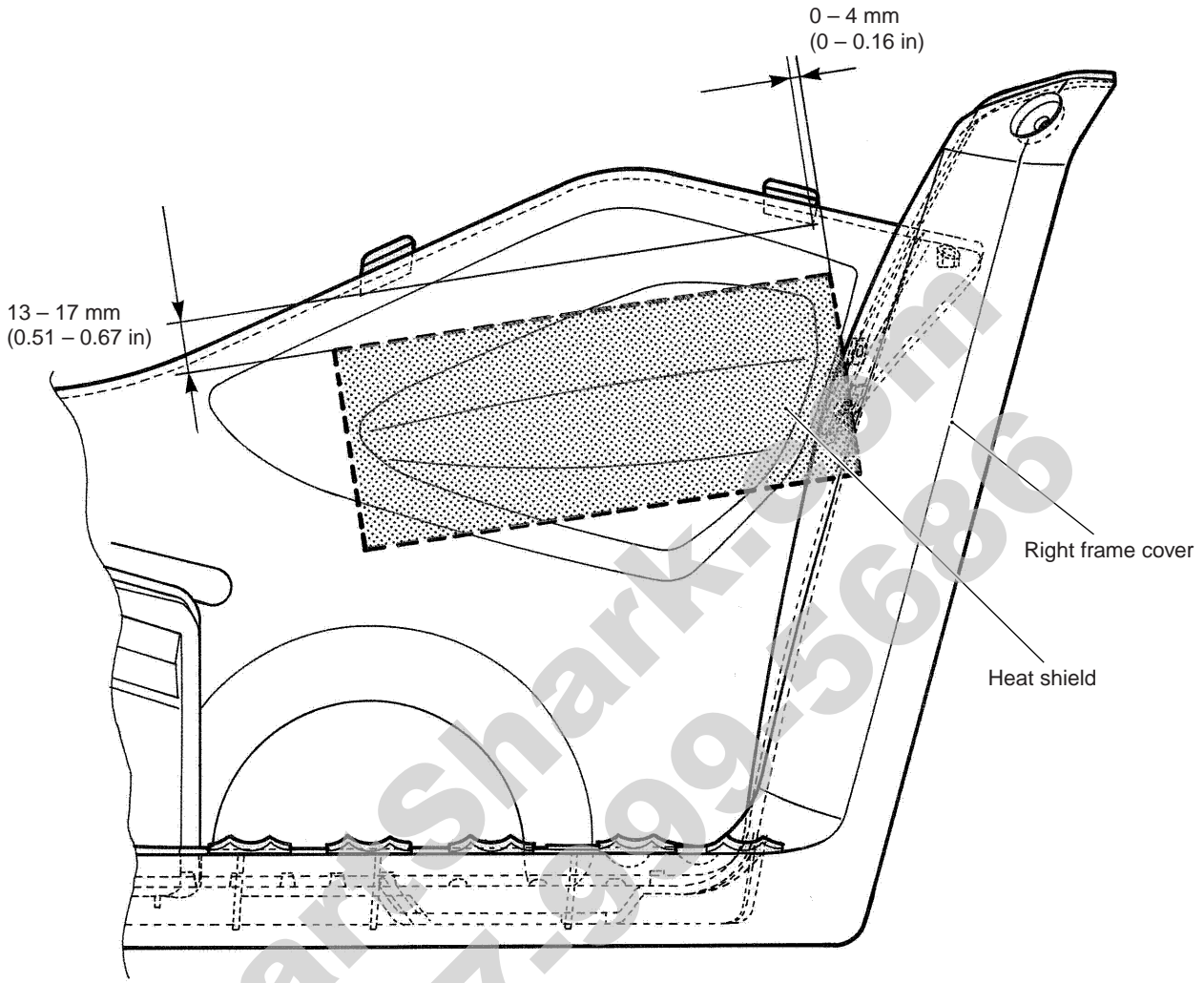

**SPECIAL TOOLS**

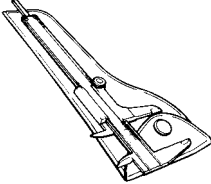
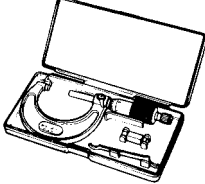
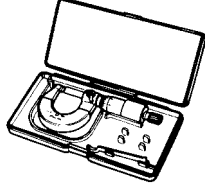
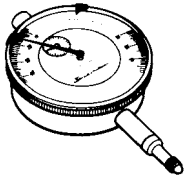
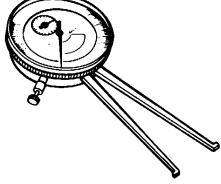
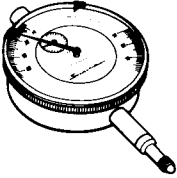
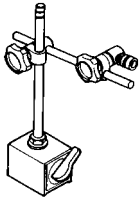
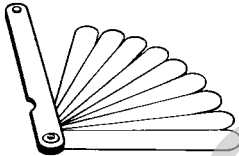
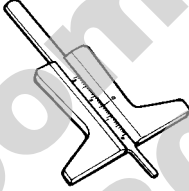
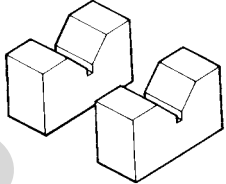
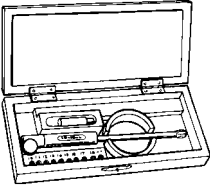
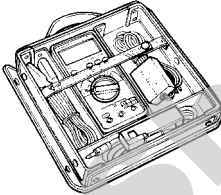
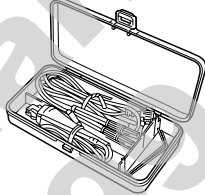
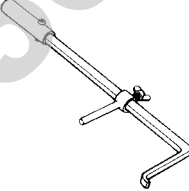
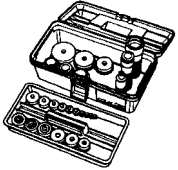
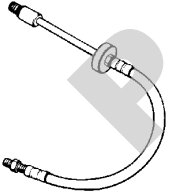
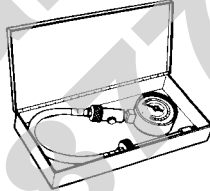
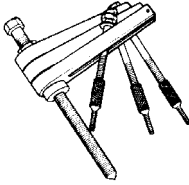
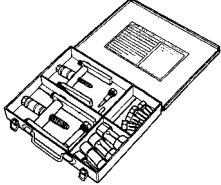
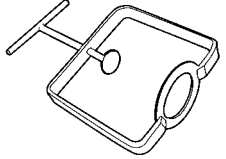
 <p><b>09900-20101</b> <b>09900-20102</b> Vernier calipers</p>	 <p><b>09900-20202</b> Micrometer (25 – 50 mm)</p>	 <p><b>09900-20205</b> Micrometer (0 – 25 mm)</p>	 <p><b>09900-20602</b> Dial gauge (1/1000 mm, 1 mm)</p>	 <p><b>09900-20605</b> Dial calipers (1/100 mm, 10 – 34 mm)</p>
 <p><b>09900-20607</b> Dial gauge (1/100 mm, 10 mm)</p>	 <p><b>09900-20701</b> Magnetic stand</p>	 <p><b>09900-20803</b> <b>09900-20806</b> Thickness gauge</p>	 <p><b>09900-20805</b> Tire depth gauge</p>	 <p><b>09900-21304</b> V-block set (100 mm)</p>
 <p><b>09900-22401 (10 – 18 mm)</b> Small bore gauge</p>	 <p><b>09900-25008</b> Multi-circuit tester set</p>	 <p><b>09900-25009</b> Needle pointed probe set</p>	 <p><b>09913-50121</b> Oil seal remover</p>	 <p><b>09913-70210</b> Bearing installer set</p>
 <p><b>09913-10750</b> Adaptor</p>	 <p><b>09915-64512</b> Compression gauge set</p>	 <p><b>09920-13120</b> Crankshaft separator</p>	 <p><b>09921-20240</b> Bearing remover set</p>	 <p><b>09922-31420</b> Clutch spring compressor</p>

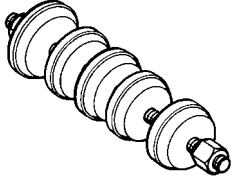
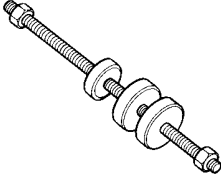
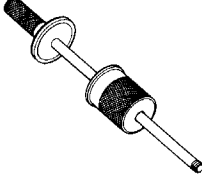
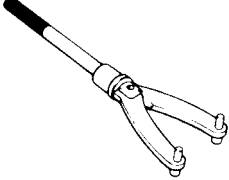
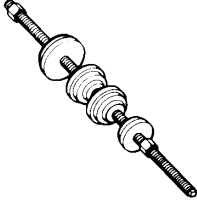
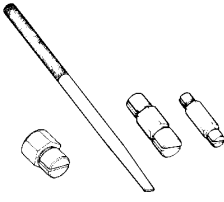
 <p><b>09923-73210</b> Bearing remover</p>	 <p><b>09924-84510</b> Bearing installer set</p>	 <p><b>09924-84521</b> Bearing installer set</p>	 <p><b>09930-30104</b> Sliding shaft</p>	 <p><b>09930-40113</b> Rotor holder</p>
 <p><b>09941-34513</b> Steering race installer</p>	 <p><b>09941-50111</b> Bearing remover</p>	<p><i>PartShark.com</i> <i>877-999-5686</i></p>		

**NOTE:**

When order the special tool, please confirm whether it is available or not.

## TIGHTENING TORQUE ENGINE

ITEM	N-m	kgf-m	lb-ft
Cylinder head cover bolt	11	1.1	8.0
Cylinder head bolt	14	1.4	10.0
Valve clearance adjuster locknut	7	0.7	5.0
Generator rotor nut	35	3.5	25.5
Clutch housing nut	50	5.0	36.0
Clutch shoe nut	60	6.0	43.5
Fixed drive face nut	Initial	13	9.5
	Final	50	36.0
Generator coil bolt	10	1.0	7.0
Pick-up coil bolt	4.5	0.45	3.0
Crankcase bolt	11	1.1	8.0
Generator case bolt	11	1.1	8.0
CVT case bolt	11	1.1	8.0
Generator cover bolt	11	1.1	8.0
CVT case cover bolt	11	1.1	8.0
Engine oil drain plug	12	1.2	8.5
Final reduction gear box cover bolt	11	1.1	8.0
Engine mounting nut	31	3.1	22.5
Muffler mounting bolt	23	2.3	16.5
Exhaust pipe nut	10	1.0	7.0
Recoil starter friction plate bolt	5.4	0.54	4.0
Spark plug	11	1.1	8.0
Carburetor mounting bolt	6	0.6	4.5
Intake pipe bolt	6	0.6	4.5

## FUEL

ITEM	N-m	kgf-m	lb-ft
Fuel valve bolt	4.5	0.45	3.3

**CHASSIS**

ITEM	N-m	kgf-m	lb-ft
Front suspension arm bolt	50	5.0	36.0
Knuckle arm nut	50	5.0	36.0
Tie-rod end nut	29	2.9	21.0
Tie-rod locknut	29	2.9	21.0
Steering shaft lower nut	29	2.9	21.0
Steering shaft holder bolt	23	2.3	16.5
Handlebar clamp bolt	26	2.6	19.0
Front shock absorber bolt	(upper) 29	2.9	21.0
	(lower) 29	2.9	21.0
Front hub nut	65	6.5	47.0
Wheel set nut (front and rear)	28	2.8	20.0
Front brake cable equalizer bolt	6.5	0.65	4.5
Front brake cam lever nut	3.3	0.33	2.5
Swingarm pivot nut	102	10.2	74.0
Rear shock absorber bolt	29	2.9	21.0
Rear shock absorber nut	29	2.9	21.0
Rear hub nut	75	7.5	54.0
Rear brake cam lever nut	7.7	0.77	5.5
Rear brake panel nut	28	2.8	20.0
Rear axle housing bolt	50	5.0	36.0
Rear sprocket bolt	23	2.3	16.5
Footrest bolt	26	2.6	19.0

## TIGHTENING TORQUE CHART

For other nuts and bolts not listed in the preceding page, refer to this chart:

Bolt Diameter Ⓐ (mm)	Conventional or "4" marked bolt			"7" marked bolt		
	N-m	kgf-m	lb-ft	N-m	kgf-m	lb-ft
4	1.5	0.15	1.0	2.3	0.23	1.5
5	3	0.3	2.0	4.5	0.45	3.0
6	5.5	0.55	4.0	10	1.0	7.0
8	13	1.3	9.5	23	2.3	16.5
10	29	2.9	21.0	50	5.0	36.0
12	45	4.5	32.5	85	8.5	61.5
14	65	6.5	47.0	135	13.5	97.5
16	105	10.5	76.0	210	21.0	152.0
18	160	16.0	115.5	240	24.0	173.5

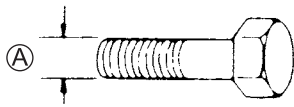

Conventional bolt

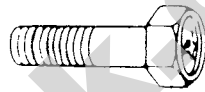

"4" marked bolt



"7" marked bolt

PartShark.com  
877-999-5686



## SERVICE DATA

### VALVE + VALVE GUIDE

Unit: mm (in)

ITEM	STANDARD		LIMIT
Valve diam.	IN.	14.5 (0.57)	—
	EX.	12.5 (0.49)	—
Valve clearance (when cold)	IN.	0.05 – 0.10 (0.002 – 0.004)	—
	EX.	0.10 – 0.15 (0.004 – 0.006)	—
Valve guide to valve stem clearance	IN.	0.010 – 0.037 (0.0004 – 0.0015)	—
	EX.	0.025 – 0.052 (0.0010 – 0.0020)	—
Valve guide I.D.	IN. & EX.	4.000 – 4.012 (0.1575 – 0.1580)	—
Valve stem O.D.	IN.	3.975 – 3.990 (0.1565 – 0.1571)	—
	EX.	3.960 – 3.975 (0.1559 – 0.1565)	—
Valve stem deflection	IN. & EX.	—	0.35 (0.014)
Valve stem runout	IN. & EX.	—	0.05 (0.002)
Valve stem end length	IN. & EX.	—	3.0 (0.12)
Valve head thickness	IN. & EX.	—	0.5 (0.02)
Valve head radial runout	IN. & EX.	—	0.03 (0.001)
Valve spring free length	IN. & EX.	—	22.8 (0.90)
Valve spring tension	IN. & EX.	36.5 – 41.9 N (3.7 – 4.3 kgf, 8.2 – 9.5 lbs) at length 15.0 mm (0.59 in)	—

**CAMSHAFT + CYLINDER HEAD**

Unit: mm (in)

ITEM	STANDARD		LIMIT
Cam height	IN. & EX.	28.43 – 28.63 (1.119 – 1.127)	28.13 (1.107)
Rocker arm I.D.	IN. & EX.	4.015 – 4.027 (0.1581 – 0.1585)	—
Rocker arm shaft O.D.	IN. & EX.	3.990 – 4.005 (0.1571 – 0.1577)	—
Cylinder head distortion	—		0.05 (0.002)

**CYLINDER + PISTON + PISTON RING**

Unit: mm (in)

ITEM	STANDARD		LIMIT	
Compression pressure	1 100 – 1 200 kPa (11 – 12 kgf/cm <sup>2</sup> , 156 – 171 psi)		800 kPa (8 kgf/cm <sup>2</sup> , 114 psi)	
Piston-to-cylinder clearance	0.015 – 0.038 (0.0006 – 0.0015)		0.120 (0.0047)	
Cylinder bore	36.005 – 36.015 (1.4175 – 1.4179)		Nicks or Scratches	
Piston diam.	35.977 – 35.990 (1.4164 – 1.4169) Measure at 5 mm (0.2 in) from the skirt end.		35.885 (1.4128)	
Cylinder distortion	—		0.05 (0.002)	
Piston ring free end gap	1st	O	Approx. 4.6 (0.18)	3.7 (0.15)
	2nd	R	Approx. 4.6 (0.18)	3.7 (0.15)
Piston ring end gap	1st	O	0.08 – 0.20 (0.003 – 0.008)	0.50 (0.020)
	2nd	R	0.08 – 0.20 (0.003 – 0.008)	0.50 (0.020)
Piston ring to groove clearance	1st	—		0.180 (0.0071)
	2nd	—		0.150 (0.0059)

ITEM	STANDARD		LIMIT
Piston ring groove width	1st	1.01 – 1.03 (0.0398 – 0.0405)	—
	2nd	1.21 – 1.23 (0.0476 – 0.0484)	—
	Oil	1.51 – 1.53 (0.0594 – 0.0602)	—
Piston ring thickness	1st	0.97 – 0.99 (0.0382 – 0.0390)	—
	2nd	1.17 – 1.19 (0.0461 – 0.0469)	—
Piston pin bore I.D.	10.002 – 10.008 (0.3938 – 0.3940)		10.030 (0.3949)
Piston pin O.D.	9.995 – 10.000 (0.3935 – 0.3937)		9.980 (0.3929)

**CONROD + CRANKSHAFT**

Unit: mm (in)

ITEM	STANDARD	LIMIT
Conrod small end I.D.	10.006 – 10.028 (0.3939 – 0.3948)	10.040 (0.3952)
Conrod deflection	—	3.0 (0.12)
Conrod big end side clearance	0.15 – 0.50 (0.006 – 0.019)	1.0 (0.04)
Conrod big end width	11.95 – 12.00 (0.470 – 0.472)	—
Crank web to web width	33.95 – 34.05 (1.337 – 1.341)	—
Crankshaft runout	—	0.08 (0.003)

**CLUTCH**

Unit: mm (in)

ITEM	STANDARD	LIMIT
Clutch housing I.D.	110.00 – 110.15 (4.331 – 4.337)	110.50 (4.350)
Clutch shoe thickness	4.0 (0.16)	3.0 (0.12)
Clutch engagement	2 400 – 3 000 r/min.	—
Clutch lock-up	3 300 – 4 300 r/min.	—

**REDUCTION GEAR + DRIVE BELT + DRIVE CHAIN**

Unit: mm (in) Except ratio

ITEM	STANDARD		LIMIT
Reduction ratio	Variable change (2.091 – 1.879)		—
Reduction gear ratio	4.272 (47/11)		—
Final reduction ratio	3.700 (37/10)		—
Drive belt width	15.9 (0.63)		14.9 (0.59)
Movable driven face spring free length	76.8 (3.02)		73.0 (2.87)
Drive chain	Type	D.I.D. 415	—
	Links	82	—
	20-pitch length	—	259.0 (10.20)
Drive chain slack	25 – 35 (1.0 – 1.4)		—

**CARBURETOR**

ITEM	SPECIFICATION
Carburetor type	MIKUNI VM13
Bore size	13 mm
I.D.No.	43G0
Idle r/min	2 000 ± 150 r/min.
Float height	23.4 ± 1.0 mm (0.92 ± 0.04 in)
Main jet (M.J.)	#58.8
Jet needle (J.N.)	3N39
Needle jet (N.J.)	E-6
Pilot jet (P.J.)	#12.5
Air screw (A.S.)	PRE-SET
Throttle cable play	3 – 5 mm (0.12 – 0.20 in)

**ELECTRICAL**

Unit: mm (in)

ITEM		STANDARD/SPECIFICATION		LIMIT	NOTE
Spark plug		Type	NGK: CR6HSA DENSO: U20FSR-U	—	
		Gap	0.6 – 0.7 (0.024 – 0.028)	—	
Spark performance		Over 8 (0.3) at 1 atm.		—	
Ignition coil resistance		Primary	0.1 – 0.7 $\Omega$	—	Terminal – Terminal
		Secondary	14 – 20 k $\Omega$	—	Plug cap – Terminal
Ignition coil primary peak voltage		150 V and more		—	⊕: Ground ⊖: B
Pick-up coil peak voltage		1.5 V and more		—	⊕: Br ⊖: Ground
Generator coil resistance		Charging	0.5 – 2.0 $\Omega$	—	W/R – Ground
		Pick-up	150 – 230 $\Omega$	—	Br – Ground
Generator no-load voltage (when engine is cold)		20 V (AC) and more at 2 800 r/min.		—	
Generator output		70 W at 5 000 r/min.		—	
Regulated voltage		13.5 – 15.2 V		—	
Starter relay resistance		70 – 90 $\Omega$		—	
Battery	Type designation	YTX5L-BS		—	
	Capacity	12 V 14.4 kC (4 Ah)/10 HR		—	
Fuse size	Main	10 A		—	
Starter motor brush length		5.5 (0.22)		2.75 (0.11)	

**BRAKE + WHEEL**

Unit: mm (in)

ITEM	STANDARD		LIMIT
Front brake lever play	4 – 6 (0.16 – 0.23)		—
Rear brake lever play	4 – 6 (0.16 – 0.23)		—
Brake drum I.D.	Front	—	80.7 (3.18)
	Rear	—	110.7 (4.36)
Rear axle runout	Rear	—	3.0 (0.12)
Wheel rim size	Front & Rear	7 × 6.0 AT	—
Toe-in (with 30 kg)	1.5 ± 3 (0.05 ± 0.12)		—
Turning radius	2.0 m (6.6 ft)		—
Camber	0°		—
Caster	3°		—
Trail	10 (0.39)		—
Steering angle	35° (Right & Left)		—

**TIRE**

Unit: mm (in)

ITEM	STANDARD		LIMIT
Cold inflation tire pressure (Solo riding)	Front	20 kPa (0.20 kgf/cm <sup>2</sup> , 2.9 psi)	—
	Rear	20 kPa (0.20 kgf/cm <sup>2</sup> , 2.9 psi)	—
Tire size	Front	AT 16 × 8-7 ☆, tubeless	—
	Rear	AT 16 × 8-7 ☆, tubeless	—
Tire tread depth	Front	—	4.0 (0.16)
	Rear	—	4.0 (0.16)

**SUSPENSION**

Unit: mm (in)

ITEM	STANDARD	LIMIT
Front wheel travel	52 (2.0)	—
Rear wheel travel	51 (2.0)	—
Swingarm pivot shaft runout	—	0.6 (0.02)

**FUEL + OIL**

ITEM	SPECIFICATION		NOTE
Fuel type	Use only unleaded gasoline of at least 87 pump octane (R/2 + M/2) or 91 octane or higher rated by the Research Method. Gasoline containing MTBE (Methyl Tertiary Butyl Ether), less than 10 % ethanol, or less than 5 % methanol with appropriate cosolvents and corrosion inhibitor is permissible.		P-03, 28
	Gasoline used should be graded 91 octane or higher. An unleaded gasoline is recommended.		The others
Fuel tank capacity	2.6 L (0.7/0.6 US/Imp gal)		
Engine oil type	SAE 10W-40, API SF/SG or SH/SJ with JASO MA		
Engine oil capacity	Change	300 ml (0.6/0.5 US/Imp qt)	
	Overhaul	350 ml (0.7/0.6 US/Imp qt)	
Final reduction gear box oil type	SAE 10W-40, API SF/SG or SH/SJ with JASO MA		
Final reduction gear box oil capacity	Change	25 ml (0.8/0.9 US/Imp oz)	
	Overhaul	30 ml (1.0/1.1 US/Imp oz)	



# LT-Z50K9 ('09-MODEL)

## CONTENTS

	PAGE
SPECIFICATIONS.....	8-2

**NOTE:**

\* Asterisk mark (\*) indicates the New K9-MODEL specifications.

\* The service data is the same as the K8-MODEL.

PartShark.com  
877-999-5686

## SPECIFICATIONS

### DIMENSIONS AND CURB MASS

Overall length .....	1 270 mm (50.0 in)
Overall width .....	760 mm (29.9 in)
Overall height .....	765 mm (30.1 in)
Wheelbase .....	830 mm (32.7 in)
Ground clearance .....	120 mm (4.7 in)
Seat height .....	535 mm (21.1 in)
Front track .....	575 mm (22.6 in)
Rear track .....	575 mm (22.6 in)
* Curb mass .....	78 kg (171 lbs)

### ENGINE

Type .....	4-stroke, air-cooled
Number of cylinders .....	1
Bore .....	36.0 mm (1.417 in)
Stroke .....	48.6 mm (1.913 in)
Displacement .....	49 cm <sup>3</sup> (3.0 cu. in)
Corrected compression ratio .....	8.4 : 1
Carburetor .....	MIKUNI VM13, single
Air cleaner .....	Polyurethane foam element
Starter system .....	Electric and recoil
Idle speed .....	2 000 ± 150 r/min

### DRIVE TRAIN

Clutch .....	Dry shoe, automatic, centrifugal type
Gearshift pattern .....	Automatic
Primary reduction ratio (Automatic drive) .....	2.091 – 1.879 (Variable change)
Secondary reduction ratio .....	4.272 (47/11)
Final reduction ratio .....	3.700 (37/10)
Drive chain .....	D.I.D. 415, 82 links

### CHASSIS

Front suspension .....	Independent, swing axle, coil spring, oil damped
Rear suspension .....	Swingarm type, coil spring, oil damped
Front wheel travel .....	52 mm (2.0 in)
Rear wheel travel .....	51 mm (2.0 in)
Caster .....	3°
Trail .....	10 mm (0.39 in)
Toe-in .....	1.5 mm (0.06 in)
Camber .....	0°
Steering angle .....	35° (right & left)
Turning radius .....	2.0 m (6.6 ft)
Front brake .....	Drum brake
Rear brake .....	Drum brake
Front tire size .....	AT16 × 8-7☆ tubeless
Rear tire size .....	AT16 × 8-7☆ tubeless

### ELECTRICAL

Ignition type .....	Electronic ignition (CDI)
Ignition timing .....	14° B.T.D.C. at 2 000 r/min
Spark plug .....	NGK CR6HSA or DENSO U20FSR-U
Battery .....	12 V 14.4 kC (4 Ah) /10 HR
Fuse .....	10 A

### CAPACITIES

Fuel tank .....	2.6 L (0.7/0.6 US/Imp gal)
Engine oil, oil change .....	300 ml (0.3/0.3 US/Imp qt)
Overhaul .....	350 ml (0.4/0.3 US/Imp qt)
Transmission oil, oil change .....	25 ml (0.8/0.9 US/Imp oz)
Overhaul .....	30 ml (1.0/1.1 US/Imp oz)