

# *ski-doo*®



SHOP  
**MANUAL**  
1999

MINI Z

484 200 007

# ***Shop Manual***

**MINI Z**

**BOMBARDIER**  
*RECREATIONAL PRODUCTS*





Legal deposit:

National Library of Quebec  
3<sup>th</sup> trimester 1998  
National Library of Canada 1998

All rights reserved. No parts of this manual may be reproduced in any form without the prior written permission of Bombardier Inc.

©Bombardier Inc. 1998

Technical Publications  
Bombardier Inc.  
Valcourt (Quebec) Canada

Printed in Canada

®\*Registered trademarks of Bombardier Inc.

This document contains the trademarks of the following companies:

Kimtowels® is a trademark of Kimberly-Clark

Loctite® is a trademark of Loctite Corporation

Metton® is a trademark of Hercules Inc.

Molykote® is a trademark of Dow Corning Corporation

Silastic® is a trademark of Dow Corning Corporation

Snap-on® is a trademark of Snap-on Tools Corporation

Versilube® is a trademark of General Electric Company

Supertanium™ is a trademark of Premier Industrial Corporation

---

# TABLE OF CONTENTS

---

<b>SECTION</b>	<b>SUBSECTION</b>	<b>PAGE</b>
SAFETY NOTICE .....		III
INTRODUCTION .....		IV
<b>01</b>	<b>SERVICE TOOLS AND SERVICE PRODUCTS</b>	
	01 – Service Tools .....	01-01-1
	02 – Service Products .....	01-02-1
<b>02</b>	<b>LUBRICATION AND MAINTENANCE</b>	
	01 – Lubrication and Maintenance Chart.....	02-01-1
<b>03</b>	<b>TROUBLESHOOTING</b>	
	01 – Table of Contents .....	03-01-1
	02 – Engine .....	03-02-1
	03 – Fuel and Oil Systems .....	03-03-1
	04 – Transmission and Brake Systems .....	03-04-1
	05 – Electrical System.....	03-05-1
	06 – Suspension and Track .....	03-06-1
<b>04</b>	<b>ENGINE</b>	
	01 – Table of Contents .....	04-01-1
	02 – Engine Removal and Installation .....	04-02-1
	03 – Valve Adjustment .....	04-03-1
	04 – Disassembly/Assembly .....	04-04-1
	05 – Compression Test and Engine Dimension Measurement.....	04-05-1
	06 – Transistorized Magneto Ignition .....	04-06-1
	07 – Rewind Starter .....	04-07-1
	08 – Carburetor .....	04-08-1
	09 – Fuel Tank and Throttle Cable.....	04-09-1
<b>05</b>	<b>TRANSMISSION</b>	
	01 – Table of Contents .....	05-01-1
	02 – Clutch .....	05-02-1
	03 – Brake .....	05-03-1
	04 – Drive Chain .....	05-04-1
<b>06</b>	<b>ELECTRICAL</b>	
	01 – Table of Contents .....	06-01-1
	02 – Spark Plugs.....	06-02-1
	03 – Testing Procedure .....	06-03-1
<b>07</b>	<b>REAR SUSPENSION</b>	
	01 – Table of Contents .....	07-01-1
	02 – Rear Suspension .....	07-02-1
	03 – Drive Axle .....	07-03-1
	04 – Track.....	07-04-1

---

---

# TABLE OF CONTENTS

---

---

<b>SECTION</b>	<b>SUBSECTION</b>	<b>PAGE</b>
<b>08</b> STEERING/ FRONT SUSPENSION	01 – Table of Contents.....	08-01-1
	02 – Steering System .....	08-02-1
	03 – Suspension and Ski System.....	08-03-1
<b>09</b> BODY AND FRAME	01 – Table of Contents.....	09-01-1
	02 – Body.....	09-02-1
	03 – Frame.....	09-03-1
<b>10</b> TECHNICAL DATA	01 – SI Metric Information Guide.....	10-01-1
	02 – Engines .....	10-02-1
	03 – Vehicles.....	10-03-1
	04 – Technical Data Legends.....	10-04-1
<b>11</b> WIRING DIAGRAM	01 – Wiring Diagram .....	11-01-1

---

# SAFETY NOTICE

This manual has been prepared as a guide to correctly service and repair Ski-Doo Mini Z snowmobile.

This edition was primarily published to be used by snowmobile mechanics who are already familiar with all service procedures relating to Bombardier made snowmobiles.

Please note that the instructions will apply only if proper hand tools and special service tools are used.

This *Shop Manual* uses technical terms which may be slightly different from the ones used in *Parts Catalog*.

It is understood that this manual may be translated into another language. In the event of any discrepancy, the english version shall prevail.

The content depicts parts and/or procedures applicable to the particular product at its time of manufacture. It does not include dealer modifications, whether authorized or not by Bombardier, after manufacturing the product.

In addition, the sole purpose of the illustrations throughout the manual, is to assist identification of the general configuration of the parts. They are not to be interpreted as technical drawings or exact replicas of the parts.

The use of Bombardier parts is most strongly recommended when considering replacement of any component. Dealer and/or distributor assistance should be sought in case of doubt.

The engine and the corresponding components identified in this document should not be utilized on product(s) other than those mentioned in this document.

Torque wrench tightening specifications must be strictly adhered to. Locking devices (ex.: locking tab, elastic stop nut, etc.) must be installed or replaced with new ones, where specified. If the efficiency of a locking device is impaired, it must be renewed.

This manual emphasizes particular information denoted by the wording and symbols:

## **WARNING**

Identifies an instruction which, if not followed, could cause serious personal injury including possibility of death.

## **CAUTION**

Denotes an instruction which, if not followed, could severely damage vehicle components.

**NOTE:** Indicates supplementary information needed to fully complete an instruction.

Although the mere reading of such information does not eliminate the hazard, your understanding of the information will promote its correct use. Always use common shop safety practice.

This information relates to the preparation and use of Bombardier snowmobiles and has been utilized safely and effectively by Bombardier Inc. However, Bombardier Inc. disclaims liability for all damages and/or injuries resulting from the improper use of the contents. We strongly recommend that any services be carried out and/or verified by a highly skilled professional mechanic. It is understood that certain modifications may render use of the vehicle illegal under existing federal, provincial and state regulations.

# INTRODUCTION

## INTRODUCTION

This *Shop Manual* covers the Ski-Doo Mini Z\* snowmobile.

\* Trademark of Bombardier Inc.

### VEHICLE SERIAL NUMBER

#### Vehicle Serial Number Location



1. Vehicle serial number

### Serial Number Meaning

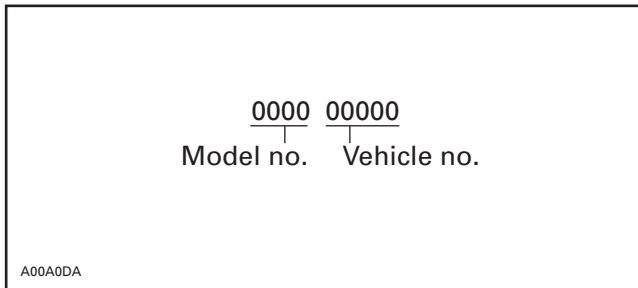

### ENGINE SERIAL NUMBER

#### Engine Serial Number Location

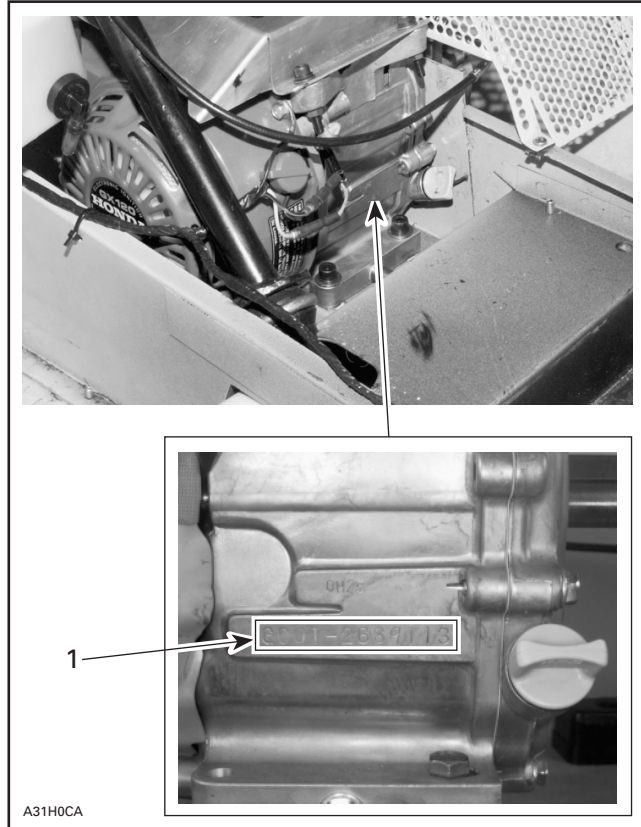

1. Engine serial number

### ARRANGEMENT OF THE MANUAL

The manual is divided into 11 major sections:

- 01 SERVICE TOOLS AND SERVICE PRODUCTS
- 02 LUBRICATION AND MAINTENANCE
- 03 TROUBLESHOOTING
- 04 ENGINE
- 05 TRANSMISSION
- 06 ELECTRICAL
- 07 REAR SUSPENSION
- 08 STEERING/FRONT SUSPENSION
- 09 BODY/FRAME
- 10 TECHNICAL DATA
- 11 WIRING DIAGRAM

Each section is divided in various subsections, and again, each subsection has one or more division.

**LIST OF ABBREVIATIONS USED  
IN THIS MANUAL**

A	ampere
amp	ampere
A•h	ampere-hour
AC	alternate current
°C	degree Celsius
cm	centimeter
cm <sup>2</sup>	square centimeter
cm <sup>3</sup>	cubic centimeter
DC	direct current
°F	degree Fahrenheit
FC	fan cooled
fl. oz	fluid ounce
ft	foot
GRD	ground
imp. oz	imperial ounce
in	inch
in <sup>2</sup>	square inch
in <sup>3</sup>	cubic inch
k	kilo (thousand)
kg	kilogram
km/h	kilometer per hour
kPa	kilopascal
L	liter
lb	pound
lbf	pound (force)
lbf/in <sup>2</sup>	pound per square inch
LH	left hand
m	meter
MAG	magneto
Max.	maximum
Min.	minimum
mL	milliliter
mm	millimeter
MPH	mile per hour
N	newton
N.A.	not applicable

no.	number
00.0	continuity
O.L	overload (open circuit)
O.D.	outside diameter
OPT	optional
oz	ounce
P/N	part number
PSI	pound per square inch
PTO	power take off
R	rectangular
RPM	revolution per minute
TDC	top dead center
U.S. oz	ounce (United States)
V	volt
Vac	volt (alternative current)



# INTRODUCTION

This *Shop Manual* uses technical terms which may be slightly different from the ones in the parts catalog.

## TYPICAL PAGE

Page heading indicates section and subsection detailed.

Subsection title indicates beginning of the subsection.

Section 07 REAR SUSPENSION  
Subsection 01 (SUSPENSION SC-10 SPORT, TOURING AND MOUNTAIN)

### SUSPENSION SC-10 SPORT, TOURING AND MOUNTAIN

Drop represents a liquid product to be applied to a surface. In this case Loctite 271 to screw threads.

Bold face number indicates special procedure concerning this part.

Exploded view assists you in identifying parts and related positions.

Illustration number for publishing process.

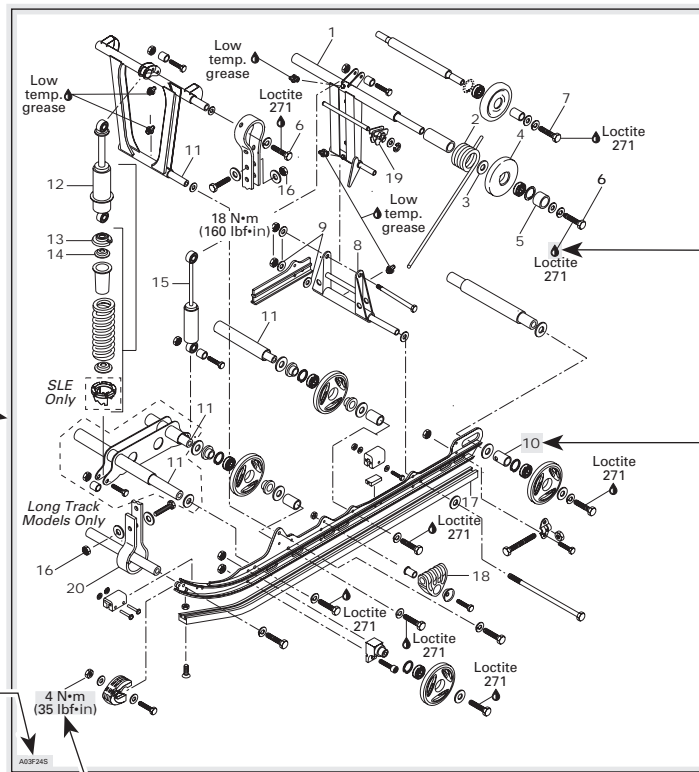

Tightening torque nearby fastener. In this case, nut must be torqued to 4 N•m or 35 lbf•in.

Page numbering system:  
07: REAR SUSPENSION section  
01: SUSPENSION SC-10 SPORT, TOURING AND MOUNTAIN subsection  
1: First page of this subsection

#### CAUTION

Pay attention to torque specifications. Some of these are in lbf•in instead of lbf•ft. Use appropriate torque wrench.

TYPICAL PAGE

Section 05 TRANSMISSION  
Subsection 03 (DRIVEN PULLEY)

Turn puller handle and sliding half at once to extract the bushing.

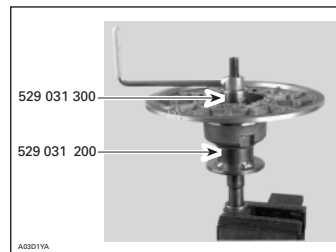

**IMPORTANT:** Large bushing retaining screws and washers must be removed before small bushing installation.

Coat bushing outside diameter with Loctite 609 (P/N 413 703 100).  
Install bushing as following photo.

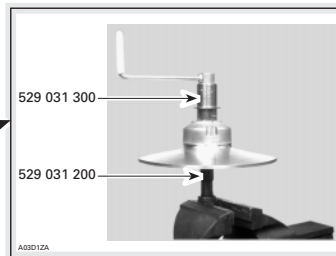

**ASSEMBLY**

**Came Slider Shoe**

When replacing slider shoes **no. 4**, always install a new set (3 shoes) to maintain equal pressure on the cam.  
Assemble driven pulley components by reversing the disassembly procedure.

**Cam**

Coat cam **no. 18** interior with anti-seize lubricant.

**INSTALLATION**

**Countershaft**

**CAUTION**

Always apply anti-seize lubricant (P/N 413 701 000) on the countershaft before final pulley installation.

Should installation procedure be required, refer to BRAKE 05-05 then look for Brake Disc and Countershaft Bearing Adjustment.

Reinstall the pulley on the countershaft by reversing the removal procedure.

Check end play of driven pulley on countershaft by pushing pulley towards outer housing so that the inner shims (P/N 504 108 200) contact it. Measure end play at the mounting screw end between shim(s) and pulley. See illustration.

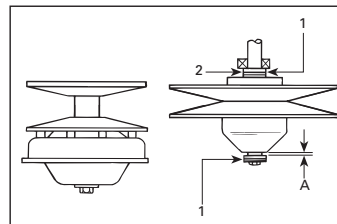

TYPICAL — TOP VIEW  
1 Shim (P/N 504 108 200) (as required)  
2 Contact  
A 0 to 1 mm (0 to 3/64 in)

Torque retaining screw **no. 13** to 25 N•m (18 lbf•ft).

**ADJUSTMENT**

Refer to PULLEY DISTANCE AND ALIGNMENT 05-04 to adjust pulley distance. Adjust drive belt height between pulley halves to obtain specified belt deflection.

Title indicates main procedure to be carried-out.

"TYPICAL" caption indicates a general view which does not represent full detail.  
"TOP VIEW" caption helps you in understanding illustration.

Call-outs for above illustration.

Reference to look up a certain section and subsection. In this case it concerns pulleys adjustment.

Illustration always follows text to which it pertains.

Subtitle indicates a particular procedure for the named part.

Number following part name refers to exploded view at beginning of subsection.

05-03-5

# INTRODUCTION

## GENERAL INFORMATION

The information and component/system descriptions contained in this manual are correct at time of publication. Bombardier Inc. however, maintains a policy of continuous improvement of its products without imposing upon itself any obligation to install them on products previously manufactured.

Due to late changes, it may have some differences between the manufactured product and the description and/or specifications in this document.

Bombardier Inc. reserves the right at any time to discontinue or change specifications, designs, features, models or equipment without incurring obligation.

## USEFUL PUBLICATIONS

Refer to *Parts Catalogs* to order the right parts.

Use *Specification Booklet* to find rapidly the right specs.

## ILLUSTRATIONS AND PROCEDURES

Illustrations and photos show the typical construction of the different assemblies and, in all cases, may not reproduce the full detail or exact shape of the parts shown, however, they represent parts which have the same or a similar function.

### ▼ CAUTION

**Most components of those vehicles are built with parts dimensioned in the metric system. Most fasteners are metric and must not be replaced by customary fasteners or vice-versa. Mismatched or incorrect fasteners could cause damage to the vehicle or possible personal injury.**

As many of the procedures in this manual are interrelated, we suggest, that before undertaking any task, you read and thoroughly understand the entire section or subsection in which the procedure is contained.

A number of procedures throughout the book require the use of special tools. Before commencing any procedure, be sure that you have on hand all the tools required, or approved equivalents.

The use of RIGHT and LEFT indications in the text, always refers to driving position (when sitting on vehicle).



**TYPICAL**

1. Left
2. Right

## TIGHTENING TORQUES

Tighten fasteners to torque mentioned in exploded views and text. When they are not specified refer to following table.

N•m	FASTENER SIZE (8.8)	Lbf•in
1		9
2	<b>M4</b>	18
3	M4	27
4	<b>M5</b>	35
5		44
6		53
7		62
8	M6	71
9	M6	80
10	<b>M6</b>	89
11	M6	97
12	M6	106
13		115
14		124
15		133
16		142
17		150
18		159
19		168

N•m	FASTENER SIZE (8.8)	Lbf•ft
20		15
21	M8	15
22	M8	16
23	<b>M8</b>	17
24	M8	18
25	M8	18
26		19
27		20
28		21
29		21
30		22
31		23
32		24
33		24
34		25
35		26
36		27
37		27
38		28

N•m	FASTENER SIZE (8.8)	Lbf•ft
39		29
40		30
41		30
42		31
43	M10	32
44	M10	32
45	M10	33
46	M10	34
47	M10	35
48	<b>M10</b>	35
49	M10	36
50	M10	37
51	M10	38
52	M10	38
53	M10	39
54		40
55		41
56		41
57		42
58		43
59		44
60		44
61		45
62		46
63		46
64		47
65		48
66		49
67		49
68		50
69		51
70		52
71		52
72		53
73		54
74		55
75		55
76	M12	56
77	M12	57
78	M12	58
79	M12	58
80	<b>M12</b>	59
81	M12	60
82	M12	60
83	M12	61

# INTRODUCTION

N•m	FASTENER SIZE (8.8)	Lbf•ft
84	M12	62
85		63
86		63
87		64
88		65
89		66
90		66
91		67
92		68
93		69
94		69
95		70
96		71
97		72
98		72
99		73
100		74
101		74
102		75
103		76
104		77
105		77
106		78
107		79
108		80
109		80
110		81
111		82
112		83
113		83
114		84
115		85
116		86
117		86
118		87
119		88
120		89
121	M14	89
122	M14	90
123	M14	91
124	M14	91
125	M14	92
126	M14	93
127	M14	94
128	M14	94

N•m	FASTENER SIZE (8.8)	Lbf•ft
129	M14	95
130	M14	96
131	M14	97
132	M14	97
133	M14	98
134	M14	99
135	<b>M14</b>	100
136	M14	100
137	M14	101
138	M14	102
139	M14	103
140	M14	103
141	M14	104
142	M14	105
143	M14	105
144	M14	106
145	M14	107
146	M14	108
147	M14	108
148	M14	109
149	M14	110
150	M14	111

*TIGHTENING TORQUES FOR 8.8 GRADE BOLTS AND NUTS*

We would be pleased if you could communicate to Bombardier any suggestions you may have concerning our publications.

## Bombardier SERVICE PUBLICATIONS REPORT

Publication title and year \_\_\_\_\_ Page \_\_\_\_\_

Machine \_\_\_\_\_ Report of error  Suggestion

---

---

---

---

---

Name \_\_\_\_\_

Address \_\_\_\_\_

City and State/Prov. \_\_\_\_\_ Date \_\_\_\_\_

Zip code/Postal code \_\_\_\_\_

---

## Bombardier SERVICE PUBLICATIONS REPORT

Publication title and year \_\_\_\_\_ Page \_\_\_\_\_

Machine \_\_\_\_\_ Report of error  Suggestion

---

---

---

---

---

Name \_\_\_\_\_

Address \_\_\_\_\_

City and State/Prov. \_\_\_\_\_ Date \_\_\_\_\_

Zip code/Postal code \_\_\_\_\_

---

## Bombardier SERVICE PUBLICATIONS REPORT

Publication title and year \_\_\_\_\_ Page \_\_\_\_\_

Machine \_\_\_\_\_ Report of error  Suggestion

---

---

---

---

---

Name \_\_\_\_\_

Address \_\_\_\_\_

City and State/Prov. \_\_\_\_\_ Date \_\_\_\_\_

Zip code/Postal code \_\_\_\_\_

AFFIX  
PROPER  
POSTAGE



**BOMBARDIER**  
*RECREATIONAL PRODUCTS*

Technical Publications  
After Sales Service  
565 de la Montagne Street  
Valcourt, Québec, Canada J0E 2L0

AFFIX  
PROPER  
POSTAGE



**BOMBARDIER**  
*RECREATIONAL PRODUCTS*

Technical Publications  
After Sales Service  
565 de la Montagne Street  
Valcourt, Québec, Canada J0E 2L0

AFFIX  
PROPER  
POSTAGE



**BOMBARDIER**  
*RECREATIONAL PRODUCTS*

Technical Publications  
After Sales Service  
565 de la Montagne Street  
Valcourt, Québec, Canada J0E 2L0

# SERVICE TOOLS

This is a list of tools to properly service Ski-Doo snowmobile models specified on cover page. The list includes both the mandatory tools and the optional tools that are ordered separately. The list of Service Products, both mandatory and optional, are not part of any kit and must all be ordered separately. If you need to replace or add to your tool inventory these items can be ordered through the regular parts channel.



Section 01 SERVICE TOOLS AND SERVICE PRODUCTS  
Subsection 01 (SERVICE TOOLS)

ENGINE — MANDATORY SERVICE TOOLS

Hose pincher (2)  
(P/N 295 000 076)

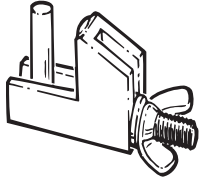

A01B2I4

**APPLICATION**  
All vehicles.

Engine leak tester kit  
(P/N 861 749 100)

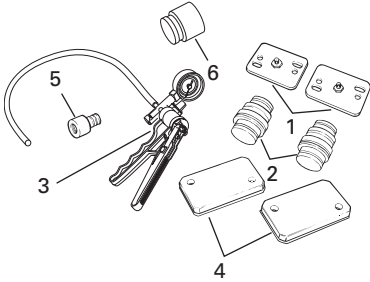

A01B2D4

**APPLICATION**  
All engines.

Fluke multimeter  
(P/N 529 022 000)

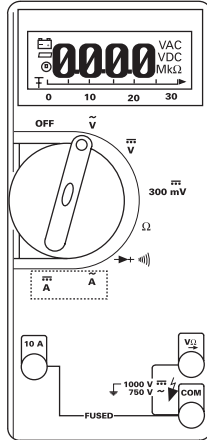

F01B1O4

**APPLICATION**  
All models.

## ENGINE (continued) — RECOMMENDED SERVICE TOOLS

The following tools are highly recommended to optimize your basic tool kit and reduce repair time.

Circuit tester  
(continuity light)  
(P/N 414 012 200)

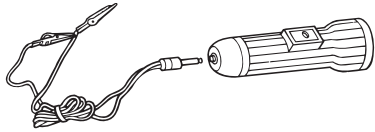

A00C214

**APPLICATION**  
All models.

Digital/induction type  
tachometer  
(P/N 529 014 500)

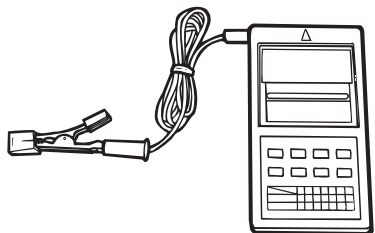

F01B1G4

**APPLICATION**  
All engines.

Exhaust spring installer/remover  
(P/N 529 028 100)

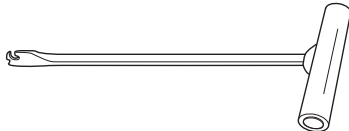

A00C3S4

**APPLICATION**  
All models.

Driver tool  
(P/N 529 035 521)



A00B4Q4

**APPLICATION**  
Crankcase bearings.

Attachment  
(P/N 529 035 522)

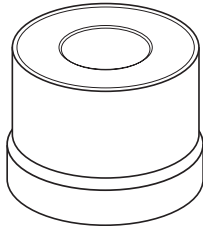

A00B4P4

**APPLICATION**  
Crankcase bearings.

Pilot 22 mm  
(P/N 529 035 523)

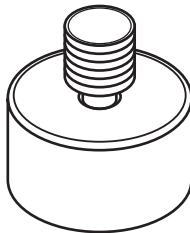

A00B4Q4

**APPLICATION**  
Crankcase bearings.

Float level gauge  
(P/N 529 035 520)

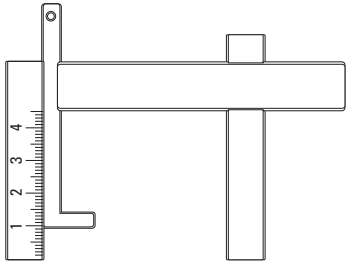

A00B4N4

**APPLICATION**  
All models.

---

Section 01 SERVICE TOOLS AND SERVICE PRODUCTS  
Subsection 01 (SERVICE TOOLS)

---

## TRANSMISSION — MANDATORY SERVICE TOOLS

Clutch holder  
(P/N 529 006 400)



A01B154

**APPLICATION**

All TRA drive pulleys and Mini Z flywheel.

Tension tester  
(P/N 414 348 200)



A03D1T4

**APPLICATION**

All models.

## TRANSMISSION (continued) — RECOMMENDED SERVICE TOOLS

The following tools are highly recommended to optimize your basic tool kit and reduce repair time.

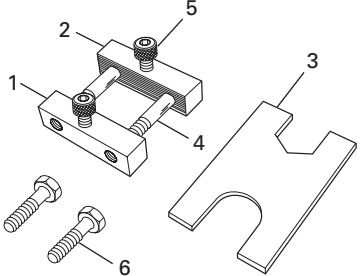
<p>Drive axle sprocket adjuster (P/N 861 725 700)</p>  <p>A01B204</p>
<p><b>APPLICATION</b> All vehicles.</p>
<p>Parts included in the kit:</p> <ul style="list-style-type: none"><li>1) Block with threads (P/N 529 010 700)</li><li>2) Block without threads (P/N 529 010 800)</li><li>3) Plate (P/N 529 010 600)</li><li>4) Bolt M10 (2) (P/N 222 007 565)</li><li>5) Allen screw M8 (2) (P/N 222 983 065)</li><li>6) Screw M8 (2) (P/N 222 082 565)</li></ul> <p><b>NOTE:</b> When the tool is to be use between tunnel and sprocket use screw M8.</p>

## SUSPENSION — RECOMMENDED SERVICE TOOLS

Track tension gauge  
(P/N 529 021 500)

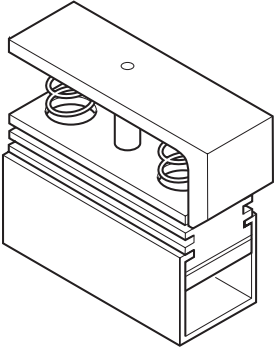

A00B3X4

### APPLICATION

All models.

Drill bit  
(P/N 529 031 800)

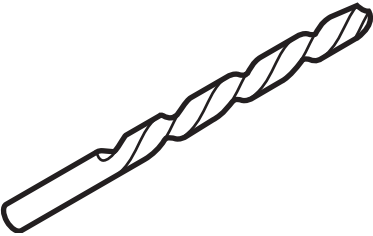

A01B564

### APPLICATION

All 3/16 in rivets.

## VEHICLES — RECOMMENDED SERVICE TOOLS

Protective mat  
(P/N 529 030 600)



A01B45W

### APPLICATION

All models.

Snowmobile jack  
(P/N 529 020 000)

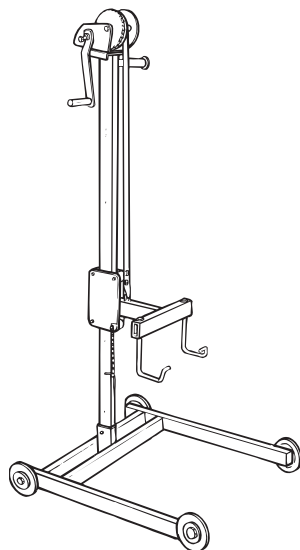

A01A1JJ

### APPLICATION

All models.

# SERVICE PRODUCTS

## MANDATORY SERVICE PRODUCTS

Medium-strength threadlocker  
(P/N 413 703 000)  
Loctite® 242  
Threadlocker (10 mL)  
(blue, medium strength)



A00B324

### APPLICATION

Flywheel nut, crankcase studs, etc.

Silicone compound  
(P/N 420 897 061)  
Dow Corning® MS4



A00B3R4

### APPLICATION

Lubricate pawl and pawl lock of  
rewind starter.

Gasket/paint remover  
(P/N 413 708 500)  
Loctite® 79040 Chisel  
510 g (18 oz)



A00B3L4

### APPLICATION

Clean mating surfaces of cylinders  
and crankcase. Remove carbon in  
combustion chambers.

## RECOMMENDED SERVICE PRODUCTS

Silicone dielectric grease  
 (3 oz)  
 (P/N 413 701 700)

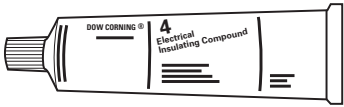

A00B1X4

**APPLICATION**  
 On all electric connections. High tension coil and spark plug connections. Connector housings, etc.

Anti-seize lubricant  
 (P/N 413 701 000)  
 Loctite anti-seize lubricant 454 g (16 oz)



F01B174

**APPLICATION**  
 Unpainted surfaces of countershaft.

Bearing grease (400 g)  
 (P/N 413 706 100)



A01B574

**APPLICATION**  
 For idler bearings, ski legs, seal interior lips drive axle bearings, suspension and steering, etc.

Storage oil  
 (350 g spray can)  
 (12 x 350 g)  
 (P/N 496 014 100)



A00B384

**APPLICATION**  
 All models.

Degreaser  
 (P/N 413 708 400)  
 Permatex® 48 TA  
 433 g (15 oz)



A00B3K4

**APPLICATION**  
 Engine, chaincase, pulleys and any greasy surfaces.

Gel instant adhesive  
 (P/N 413 708 300)  
 Loctite 454-40  
 20 g (.70 oz)



A00B3O4

**APPLICATION**  
 Isolating foam and rubber strip.

Tough adhesive  
 (P/N 413 408 300)  
 Loctite Black Max 38004  
 3 mL (.10 oz)



A00B3P4

**APPLICATION**  
 Shifter boot or grip.

Stripped threads repair kit  
 (P/N 413 708 600)  
 Loctite 81668  
 Form-A-thread 81668

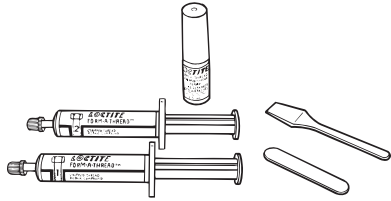

A00A1J4

**APPLICATION**  
 Repair damaged threads of grade 5 (SAE) or 8.8 (metric) maximum. Do not use in applications where temperatures will exceed 149°C (300°F) or on critical assemblies.



Section 01 SERVICE TOOLS AND SERVICE PRODUCTS  
Subsection 02 (SERVICE PRODUCTS)

General purpose instant adhesive  
Loctite 495 (3 g)  
(P/N 413 703 200)

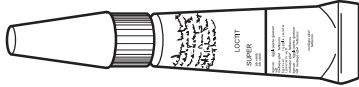

A00B2V4

**APPLICATION**

Rubber to metal bonding and  
most hard plastic.

Fuel stabilizer  
(12 x 8 oz)  
(P/N 413 408 600)



A00B3V4

**APPLICATION**

All models.

BOMBARDIER LUBE  
(12 x 14 oz)  
(P/N 293 600 016)



A01B4P4

**APPLICATION**

Steering ball joints on all models.

Super Lube (grease)  
(P/N 293 550 014)









A00B474

**APPLICATION**





Tie rod bushings.

Section 02 LUBRICATION AND MAINTENANCE  
Subsection 01 (LUBRICATION AND MAINTENANCE CHART)

# LUBRICATION AND MAINTENANCE CHART

SYSTEM	PART/TASK	10-HOUR INSPECTION (to be performed by dealer)	WEEKLY	MONTHLY	ONCE A YEAR	STORAGE (to be performed by dealer)	PRE-SEASON PREPARATION (to be performed by dealer)	REFER TO
	Rewind Starter Lubrication and Rope Condition						✓	Subsection 04-07
	Engine Head Nuts	✓			✓			Appropriate section: See TOP END
	Engine Mount Nuts	✓			✓			Appropriate section: See ENGINE REMOVAL
	Exhaust System	✓		✓			✓	Appropriate section: See ENGINE REMOVAL
	Engine Lubrication					✓		This section no. 3
	Cooling System Condition	✓			✓		✓	Subsection 04-06
	Valve Clearance				✓			Subsection 04-03
	Condition of Seals						✓	Subsection 04-04
	Oil Level	EACH USE						This section no. 1
	Oil Change	✓	6 MONTHS					
	Fuel Filter Replacement						✓	This section no. 5
	Fuel Strainer Cleaning						✓	This section no. 6
	Fuel Lines and Connections	✓					✓	Subsection 04-09
	Carburetor Adjustment	✓			✓		✓	Subsection 04-08
	Throttle Cable Inspection	✓			✓		✓	Subsection 04-09
	Condition of Drive and Driven Sprockets	✓		✓		✓	✓	Subsections 05-03 and 05-04
	Lubrication of Drive and Driven Sprockets	✓		✓		✓	✓	Subsections 05-03 and 05-04
	Retorquing of Clutch Screw	✓		✓		✓	✓	Subsection 05-02
	Brake Condition	✓	✓				✓	Subsection 05-03
	Brake Adjustment			✓			✓	Subsection 05-03
	Drive Chain Tension and Lubrication	✓		✓		✓	✓	Subsection 05-04
	Lubrication of Drive Axle Bearing	✓		✓		✓		Subsection 07-03

Section 02 LUBRICATION AND MAINTENANCE  
 Subsection 01 (LUBRICATION AND MAINTENANCE CHART)

SYSTEM	PART/TASK	10-HOUR INSPECTION (to be performed by dealer)	WEEKLY	MONTHLY	ONCE A YEAR	STORAGE (to be performed by dealer)	PRE-SEASON PREPARATION (to be performed by dealer)	REFER TO
	Steering and Front Suspension Mechanism	✓		✓		✓	✓	Subsections 08-02 and 08-03
	Wear and Condition of Skis and Runners	✓	✓					Subsection 08-03
	Suspension Lubrication			✓		✓		Section 07: See appropriate subsection
	Suspension Condition	✓			✓		✓	Section 07: See appropriate subsection
	Suspension Stopper Straps Condition				✓		✓	Section 07: See appropriate subsection
	Track Condition	✓		✓			✓	Subsection 07-04
	Track Tension and Alignment	✓	AS REQUIRED					
	Spark Plug *	✓		✓			✓	Subsection 06-03
	Headlight Beam Aiming				✓			Subsection 09-03
	Wiring Harnesses, Cables and Lines	✓		✓				Subsection 09-03
	Operation of Lighting System (Headlight and Taillight) Test Operation of Emergency Cut-out Switch and Tether Cut-out Switch	✓	✓				✓	<i>Operator's Guide</i>
	Rags in Air Intake and Exhaust System					✓	✓	This section no. 8
	Engine Compartment	✓		✓			✓	This section no. 9
	Vehicle Cleaning and Protection	✓		✓		✓		This section no. 10

\* Before installing new spark plug at pre-season preparation, it is suggested to burn excess storage oil by starting the engine with the old spark plug. Only perform this operation in a well ventilated area.

## NO. 1 ENGINE OIL LEVEL

With snowmobile on a level surface, check the oil level by removing dipstick at engine base.

Oil level must be to the top of the oil filler neck. If not, refill up to oil filler neck using SAE 5W/30 recommended oil. Refer to TECHNICAL DATA.

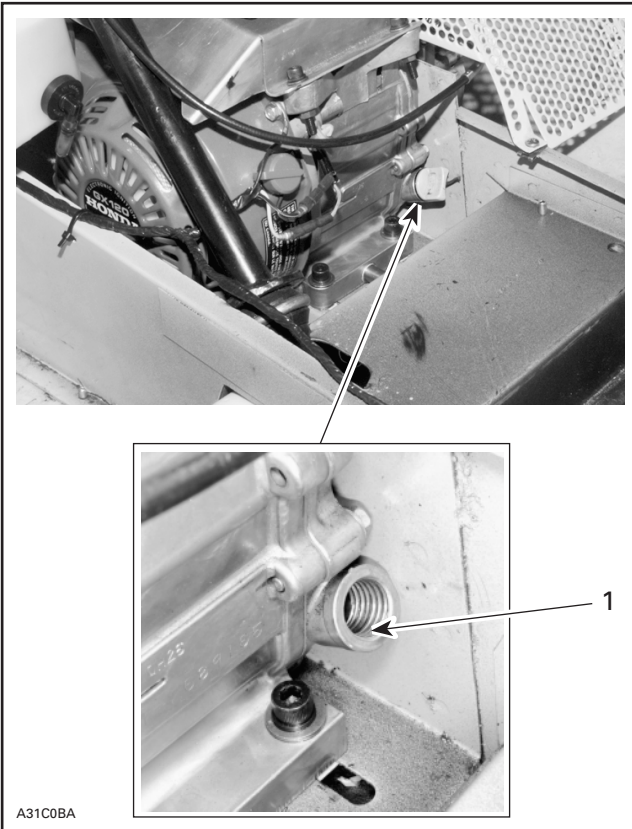

ADD OIL UNTIL IT REACHES THE TOP OF THE OIL FILLER NECK  
1. Top of the oil filler neck

## NO. 2 ENGINE OIL CHANGE

Refer to LUBRICATION AND MAINTENANCE CHART 02-01.

To drain oil from engine, **hold pipe** using a key then unscrew cap from underneath front of snowmobile. See next photo.

**NOTE:** To completely drain oil from engine, keep snowmobile leveled.

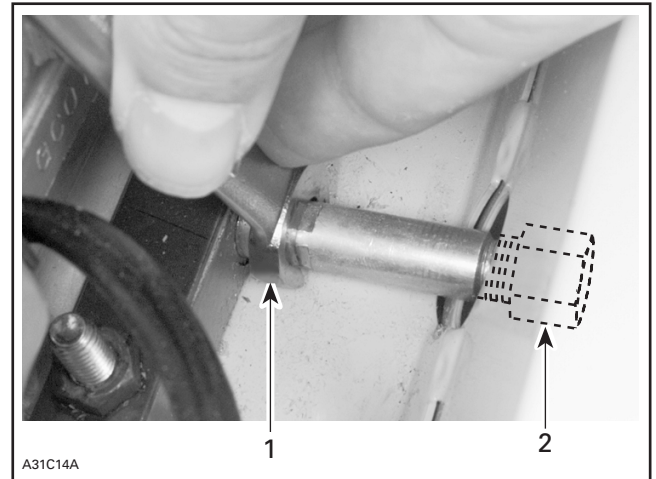

1. Hold pipe  
2. Remove oil drain cap

## NO. 3 ENGINE LUBRICATION

Engine internal parts must be lubricated to protect them from possible rust formation during the storage period.

Proceed as follows:

Start the engine and allow it to run at idle speed until the engine reaches its operating temperature.

### ◆ WARNING

Ensure the track is free of all particles which could be thrown out while it is rotating. Keep hands, tools, feet and clothing clear of track. Ensure no one is standing in close proximity to the vehicle.

Stop the engine.

Remove carburetor cap to spray storage oil into carburetor bore.

Restart engine and run at idle speed.

Inject storage oil until the engine stalls or until a sufficient quantity of oil has entered the engine (approximately half a can).

With the engine stopped, remove the spark plug and spray storage oil (P/N 496 014 100) into cylinder.

Crank slowly 2 or 3 revolutions to lubricate cylinder.

Reinstall the spark plug.

**◆ WARNING**

This procedure must only be performed in a well ventilated area. Do not run engine during storage period.

### NO. 4 FUEL STABILIZER

A fuel stabilizer (P/N 413 408 600) can be added in fuel tank to prevent fuel deterioration and avoid draining fuel system for storage. Follow manufacturer's instructions for proper use.

If above fuel stabilizer is not used, drain fuel system including fuel tank and carburetor.

**▼ CAUTION**

Fuel stabilizer should be added prior the engine lubrication to ensure carburetor(s) protection against varnish deposit.

### NO. 5 FUEL FILTER REPLACEMENT

Drain fuel tank.

Remove fuel line grommet from fuel tank and pull out inlet fuel line from tank.

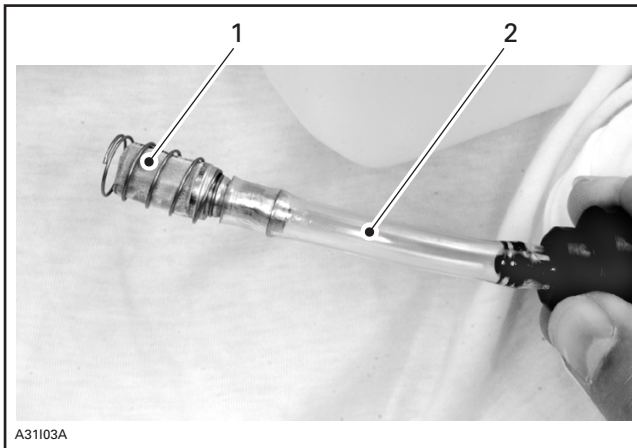

1. Fuel filter
2. Fuel hose

Replace fuel filter.

### NO. 6 FUEL STRAINER

Turn off fuel valve.



FUEL VALVE TO "OFF" POSITION

Remove the strainer cup, as shown in the next photo.

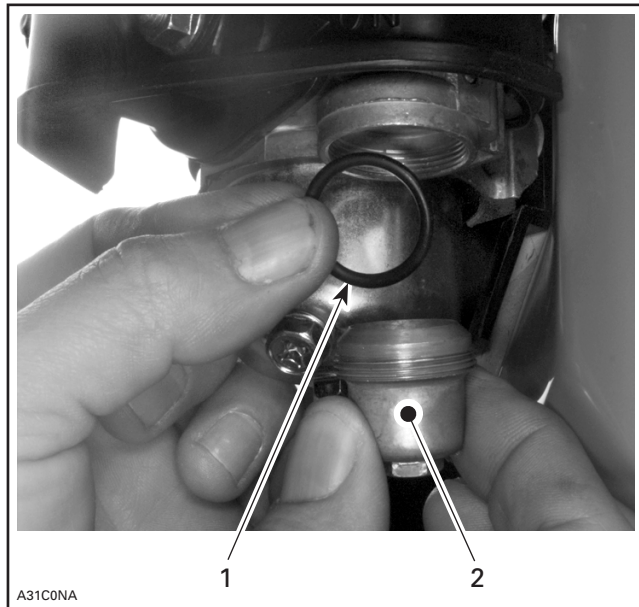

REMOVE STRAINER CUP

1. O-ring
2. Strainer cup

Clean the strainer cup with cleaning solvent (P/N 413 708 200).

Reinstall strainer cup with O-ring and tighten to 4 N•m (36 lbf•in).

## NO. 7 DRIVE CHAIN CONDITION

Visually inspect the chain for cracked, damaged or missing link rollers.

Check for defective bearings, sprockets and worn chain tensioner components.

Lubricate drive chain as per lubrication chart.

Use BOMBARDIER LUBE (P/N 293 600 000).

### ▼ CAUTION

Always lubricate drive chain slightly. Oil must not contact brake pad.

## NO. 8 RAGS IN AIR INTAKE AND EXHAUST SYSTEM

At storage preparation, block air intake hole and exhaust system hole using clean rags.

Remove those rags at pre-season preparation.

## NO. 9 ENGINE COMPARTMENT

Keep clean of grass, twigs, cloth, etc. These are combustible under certain conditions.

## NO. 10 VEHICLE CLEANING AND PROTECTION

Remove any dirt or rust.

To clean the entire vehicle, use only flannel clothes or Kimtowels® wipers no. 58-380 from Kimberly-Clark.

### ▼ CAUTION

It is necessary to use flannel cloths or Kimtowels wipers on windshield and hood to avoid damaging further surfaces to clean.

To clean the entire vehicle, including metallic parts with a **thick** coat of grease, use Endust® imported by Bristol Myers, available at hardware stores or supermarkets.

For bottom pan cleaning, use Bombardier Cleaner (P/N 293 110 001 (spray can 400 g) and 293 110 002 (4 L)).

### ▼ CAUTION

Do not use Bombardier Cleaner on decals or vinyl.

To clean the entire vehicle, including metallic parts with a **thin** coat of grease, use Simple Green® from Sunshine Makers Inc., available at hardware stores or at automotive parts retailer.

For vinyl and plastic parts, use Vinyl & Plastic Cleaner (P/N 413 711 200 (6 x 1 L)).

To remove scratches on windshield or hood: Start with "Slip Streamer Motorcycle Windshield Heavy Duty Scratch, Remover". Finish with "Slip Streamer Motorcycle Cleaner and Polish".

**NOTE:** The latest product may be use alone if only light scratches are noticeable.

### ▼ CAUTION

Never clean plastic parts or hood with strong detergent, degreasing agent, paint thinner, acetone, products containing chlorine, etc.

Inspect the hood and repair any damage. Touch up all metal spots where paint has been scratched off. Spray all metal parts with BOMBARDIER LUBE (P/N 293 600 016). Wax the hood and the painted portion of the frame for better protection.

**NOTE:** Apply wax on glossy finish only. Protect the vehicle with a cover to prevent dust accumulation during storage.

### ▼ CAUTION

The snowmobile has to be stored in a cool and dry place and covered with an opaque tarpaulin. This will prevent sun rays and grime from affecting plastic components and vehicle finish.

Lift rear of vehicle until track is clear of the ground. Install on a snowmobile mechanical stand.

**NOTE:** Do not release track tension.

# TABLE OF CONTENTS

---

<b>ENGINE .....</b>	<b>03-02-1</b>
<b>FUEL AND OIL SYSTEMS .....</b>	<b>03-03-1</b>
<b>TRANSMISSION AND BRAKE SYSTEMS .....</b>	<b>03-04-1</b>
<b>TRANSMISSION .....</b>	<b>03-04-1</b>
<b>BRAKE SYSTEM .....</b>	<b>03-04-2</b>
<b>MECHANICAL BRAKE .....</b>	<b>03-04-2</b>
<b>ELECTRICAL SYSTEM.....</b>	<b>03-05-1</b>
<b>SUSPENSION AND TRACK .....</b>	<b>03-06-1</b>

---

# ENGINE

The following chart is provided to help in diagnosing the probable source of troubles. It should be used as a guideline.

<b>SYMPTOM</b>	<b>ENGINE BACKFIRES.</b>
<b>CONDITION</b>	NORMAL USE.
<b>Test/Inspection</b>	<b>1. Check spark plug.</b> a. Carbon accumulation caused by defective spark plug. <i>Clean carbon accumulation and replace spark plug.</i>
	<b>2. Check ignition timing.</b> a. Timing is fixed but ensure that woodruff key holding flywheel is in place.

<b>SYMPTOM</b>	<b>ENGINE DOES NOT OFFER MAXIMUM POWER AND/OR DOES NOT REACH MAXIMUM OPERATING RPM.</b>
<b>CONDITION</b>	NORMAL USE.
<b>Test/Inspection</b>	<b>1. Check spark plug condition.</b> a. Fouled spark plug(s). <i>Replace.</i>
	<b>2. Check if there is water in fuel.</b> a. There is water in fuel. <i>Drain fuel system, then fill it with appropriate fuel.</i>
	<b>3. Check governor adjustment.</b> a. Governor out of adjustment. <i>Readjust.</i>
	<b>4. Check carburetor adjustments and cleanliness.</b> a. Inadequate carburetor adjustments or dirt accumulation. <i>Adjust according to specifications (refer to TECHNICAL DATA 10) or clean.</i>
	<b>5. Check valve clearance.</b> a. Valve clearance incorrect. <i>Readjust.</i>
	<b>6. Check valve condition.</b> a. Valve or valve seat worn or damaged. <i>Inspect and correct.</i>
	<b>7. Check track adjustment.</b> a. Too much tension and/or improper alignment. <i>Align track and adjust its tension to specifications (refer to TECHNICAL DATA 10).</i>



## Section 03 TROUBLESHOOTING

### Subsection 02 (ENGINE)

	<b>8. Check exhaust system.</b> a. Restriction. <i>Replace.</i>
	<b>9. Check ignition system.</b> a. Decrease in power due to incorrect ignition. <i>Check spark plug and ignition coil operation.</i>
	<b>10. Check engine compression.</b> a. Worn piston(s) and ring(s). <i>Replace (refer to TECHNICAL DATA 10 for specification).</i>

SYMPTOM	ENGINE DETONATION AT MAXIMUM RPM.
CONDITION	NORMAL USE.
Test/Inspection	<b>1. Check which type of fuel is used.</b> a. Octane number is too low and/or alcohol level is too high. <i>Use recommended fuel type.</i>
	<b>2. Check spark plug type.</b> a. Improper spark plug heat range. <i>Install recommended spark plug(s) (refer to TECHNICAL DATA 10).</i>
	<b>3. Check exhaust system.</b> a. Too much restriction. <i>Replace.</i>
	<b>4. Check ignition system.</b> a. Incorrect ignition. <i>Check spark plug and ignition coil operation.</i>
	<b>5. Check carburetion.</b> a. Fouled and/or improper carburetor components. <i>Clean or replace according to specification (refer to TECHNICAL DATA 10).</i>

**Section 03 TROUBLESHOOTING**

**Subsection 02 (ENGINE)**

<b>SYMPTOM</b>	<b>ENGINE TURNS OVER BUT FAILS TO START.</b>
<b>CONDITION</b>	NORMAL USE.
<b>Test/Inspection</b>	<p><b>1. Check switches.</b></p> <p>a. Ignition switch, emergency cut-out switch or tether switch is in the OFF position. <i>Place all switches in the RUN or ON position.</i></p>
	<p><b>2. Check fuel level.</b></p> <p>a. Mixture not rich enough to start cold engine. <i>Check fuel tank level and use choke.</i></p>
	<p><b>3. Check spark plug.</b></p> <p>a. Defective spark plug (no spark). <i>Replace spark plug.</i></p>
	<p><b>4. Check amount of fuel on spark plug.</b></p> <p>a. Spark plug wet (flooded engine). <i>Clean and dry spark plug. Reinstall spark plug and start engine taking care not to use choke. If flooding is severe, check carburetor float valve, then change engine oil.</i></p> <p>b. Spark plug dry (no fuel to the engine). <i>Check fuel tank level; check if fuel valve is opened: check fuel strainer, clean if clogged; check condition of fuel lines and their connections. Check carburetor main jet and nozzle.</i></p>
	<p><b>5. Check the ignition system.</b></p> <p>a. No spark or weak spark. <i>Replace parts as indicated in section electrical system.</i></p>
	<p><b>6. Check engine compression.</b></p> <p>a. Insufficient engine compression. <i>Check valve clearance; carbon accumulation; defective cylinder head gasket, valves or valve seats; Check for worn piston rings, piston or cylinder. Replace defective part(s) (ex. : piston(s), ring(s), etc.).</i></p>

## Section 03 TROUBLESHOOTING

### Subsection 02 (ENGINE)

<b>SYMPTOM</b>	<b>IRREGULAR ENGINE IDLE.</b>
<b>CONDITION</b>	NORMAL USE AFTER ENGINE WARM UP.
<b>Test/Inspection</b>	<b>1. Check choke.</b> a. Choke plate may be partially closed. <i>Readjust.</i>
	<b>2. Check pilot screw position.</b> a. Inadequate fuel/air mixture. <i>Adjust according to specifications (refer to TECHNICAL DATA 10).</i>
	<b>3. Check ignition system coil air gap.</b> a. Air gap is too large. <i>Adjust according to specifications (refer to TECHNICAL DATA 10).</i>
	<b>4. Check dimension of main jet.</b> a. Inadequate fuel/air mixture. <i>Adjust according to specifications (refer to TECHNICAL DATA 10).</i>
	<b>5. Check engine compression.</b> a. Insufficient engine compression. <i>Check valve clearance; carbon accumulation; defective cylinder head gasket, valves or valve seats. Check for worn piston rings, piston or cylinder. Replace defective part(s) (ex.: piston(s), ring(s), etc.).</i>

<b>SYMPTOM</b>	<b>HIGH ENGINE OPERATING TEMPERATURE.</b>
<b>CONDITION</b>	NORMAL USE.
<b>Test/Inspection</b>	<b>1. Check cooling fins of engine.</b> a. Dirt accumulation between engine fins. <i>Clean thoroughly.</i>
	<b>2. Check carburetion.</b> a. Improperly adjusted or inadequate carburetor components. <i>Adjust according to specifications (refer to TECHNICAL DATA 10) or replace inadequate component(s).</i>
	<b>3. Check cylinder head gasket.</b> a. Worn gasket. <i>Replace.</i>
	<b>4. Check condition and heat range of spark plug.</b> a. Melted spark plug tip or inadequate heat range. <i>Replace.</i>
	<b>5. Check exhaust condition.</b> a. Carbon deposit. <i>Clean.</i>

**Section 03 TROUBLESHOOTING**  
Subsection 02 (ENGINE)

<b>SYMPTOM</b>	<b>REWIND STARTER ROPE DOES NOT REWIND.</b>
<b>CONDITION</b>	NORMAL USE.
<b>Test/Inspection</b>	<p><b>1. Check rewind spring.</b></p> <p>a. Broken spring. <i>Replace spring.</i></p>

<b>SYMPTOM</b>	<b>REWIND STARTER RATCHET DOES NOT ENGAGE.</b>
<b>CONDITION</b>	NORMAL USE.
<b>Test/Inspection</b>	<p><b>1. Check ratchet and ratchet guide.</b></p> <p>a. Ratchet and ratchet guide have stuck together because of dirt or heat. <i>Clean or replace.</i></p> <p><b>2. Check ratchet and rope sheave.</b></p> <p>a. Ratchet and rope sheave have stuck together because of heat. <i>Replace.</i></p>

<b>SYMPTOM</b>	<b>ENGINE PINGING.</b>
<b>CONDITION</b>	NORMAL USE.
<b>Test/Inspection</b>	<p><b>1. Check fuel lines.</b></p> <p>a. Bent fuel lines (preventing fuel from flowing through). <i>Relocate or replace fuel lines.</i></p> <p><b>2. Check if carburetor is clean.</b></p> <p>a. Dirt prevents fuel from flowing through. <i>Clean.</i></p>

# FUEL AND OIL SYSTEMS

The following chart is provided to help in diagnosing the probable source of troubles. It should be used as a guideline.

<b>SYMPTOM</b>	<b>HIGH FUEL CONSUMPTION OR RICH MIXTURE.</b>
<b>CONDITION</b>	NORMAL USE.
<b>Test/Inspection</b>	<p><b>1. Check fuel tank.</b> a. Perforated fuel tank. <i>Replace fuel tank.</i></p> <p><b>2. Check carburetor fittings.</b> a. Leaking fittings. <i>Replace defective part.</i></p> <p><b>3. Check float height in carburetor(s).</b> a. Fuel level is too high in float bowl. <i>Adjust according to specifications (refer to TECHNICAL DATA 10).</i></p>

<b>SYMPTOM</b>	<b>ENGINE LACKS POWER OR STALLS AT HIGH RPM.</b>
<b>CONDITION</b>	NORMAL USE.
<b>Test/Inspection</b>	<p><b>1. Check fuel filter or strainer.</b> a. Clogged filter or strainer. <i>Clean.</i></p> <p><b>2. Check fuel lines.</b> a. Kinked or clogged lines. <i>Relocate or replace.</i></p> <p><b>3. Check if carburetor is clean.</b> a. Varnish. <i>Clean.</i></p>

<b>SYMPTOM</b>	<b>ENGINE RUNS OUT OF FUEL (OR LEAN MIXTURE).</b>
<b>CONDITION</b>	NORMAL USE.
<b>Test/Inspection</b>	<p><b>1. Check fuel filter or strainer.</b> a. Clogged filter or strainer. <i>Clean.</i></p> <p><b>2. Check if lines are perforated or kinked and make sure they do not leak at fittings.</b> a. Lines are too big for their fittings or are improperly routed. <i>Replace or properly relocate lines.</i></p> <p><b>3. Check main jet.</b> a. Dirt (varnish, foreign particle) accumulation at main jet. <i>Clean.</i></p> <p><b>4. Check float height in carburetor bowl.</b> a. Running out of fuel at high speed because float height is too low. <i>Adjust float lever height according to specification.</i></p>

# TRANSMISSION AND BRAKE SYSTEMS

The following charts are provided to help in diagnosing the probable source of troubles. It should be used as a guideline.

## TRANSMISSION

<b>SYMPTOM</b>	<b>LOOSENESS IS FELT IN DRIVE SYSTEM WHEN ACCELERATING/DECELERATING.</b>
<b>CONDITION</b>	NORMAL USE.
<b>Test/Inspection</b>	<b>1. Check drive chain tension.</b> a. Drive chain automatic tensioner is too loose. <i>Replace tensioner.</i> b. Drive chain is worn out. <i>Replace drive chain with new one.</i>

<b>SYMPTOM</b>	<b>VIBRATIONS ORIGINATING FROM DRIVEN SPROCKET.</b>
<b>CONDITION</b>	NORMAL USE.
<b>Test/Inspection</b>	<b>1. Check driven sprocket hub fit with drive axle.</b> a. Driven sprocket is loosened on drive axle. <i>Replace driven sprocket or drive axle.</i>

<b>SYMPTOM</b>	<b>VIBRATIONS ORIGINATING FROM DRIVE SPROCKET.</b>
<b>CONDITION</b>	NORMAL USE.
<b>Test/Inspection</b>	<b>1. Check tightening torque of drive sprocket screw.</b> a. Moving drive sprocket. <i>Retighten screw.</i> b. Worn key way. <i>Replace parts.</i>

<b>SYMPTOM</b>	<b>CLUTCH DO NOT OPERATE PROPERLY.</b>
<b>CONDITION</b>	NORMAL USE.
<b>Test/Inspection</b>	<b>1. Replace clutch with new one.</b>

## Section 03 TROUBLESHOOTING

### Subsection 04 (TRANSMISSION AND BRAKE SYSTEMS)

<b>SYMPTOM</b>	<b>EXCESSIVE NOISE WITH DRIVE CHAIN.</b>
<b>CONDITION</b>	NORMAL USE.
<b>Test/Inspection</b>	<ol style="list-style-type: none"><li><b>1. Check drive chain lubrication.</b><ol style="list-style-type: none"><li>a. Drive chain is dry. <i>Lubricate drive chain.</i></li></ol></li><li><b>2. Check drive chain condition.</b><ol style="list-style-type: none"><li>a. Chain is cracked, damaged or some link rollers are missing. <i>Replace drive chain.</i></li></ol></li><li><b>3. Check sprockets.</b><ol style="list-style-type: none"><li>a. Excessive wear at sprocket teeth. <i>Replace sprockets.</i></li></ol></li></ol>

## BRAKE SYSTEM

### MECHANICAL BRAKE

<b>SYMPTOM</b>	<b>BRAKE HANDLE DOES NOT RETURN COMPLETELY.</b>
<b>CONDITION</b>	NORMAL USE.
<b>Test/Inspection</b>	<ol style="list-style-type: none"><li><b>1. Check brake return spring.</b><ol style="list-style-type: none"><li>a. Broken return spring. <i>Replace.</i></li></ol></li><li><b>2. Check if brake cable moves freely in its housing.</b><ol style="list-style-type: none"><li>a. Brake cable movement is limited due to oxidation or dirt accumulation. <i>Replace.</i></li></ol></li><li><b>3. Check distance between brake lever and caliper.</b><ol style="list-style-type: none"><li>a. Distance is too wide. <i>Adjust according to specifications (refer to TRANSMISSION 05).</i></li></ol></li></ol>

<b>SYMPTOM</b>	<b>BRAKE SYSTEM IS NOISY.</b>
<b>CONDITION</b>	NORMAL USE.
<b>Test/Inspection</b>	<ol style="list-style-type: none"><li><b>1. Check brake pad thickness.</b><ol style="list-style-type: none"><li>a. Pad is worn up to wear limit. <i>Replace.</i></li></ol></li><li><b>2. Check brake attachment.</b><ol style="list-style-type: none"><li>a. Attachment is loose or cracked. <i>Tighten or replace.</i></li></ol></li><li><b>3. Check brake pad alignment.</b><ol style="list-style-type: none"><li>a. Brake pad is not properly aligned with clutch. <i>Rotate brake pad 180° or replace with new one.</i></li></ol></li></ol>

# ELECTRICAL SYSTEM

The following chart is provided to help in diagnosing the probable source of troubles. It should be used as a guideline.

SYMPTOM	HEADLAMP NOT LIGHTING.
CONDITION	WHITE BULB.
Test/Inspection	<b>1. Check bulb.</b> a. Burnt bulb. <i>Replace bulb.</i>
CONDITION	BROKEN ELEMENT.
Test/Inspection	<b>1. Check for loose headlamp housing and bulb socket.</b> a. Vibration problem. <i>Tighten headlamp mounting screws. Lock bulb in socket. Replace bulb.</i>
CONDITION	MELTED FILAMENT (ENDS OF ELEMENT HOLDER) AND BLACK BULB.
Test/Inspection	<b>1. Check voltage at headlamp at different speeds. It must not be above 15 Vac.</b> a. Excessive voltage in lighting circuit. <i>Ensure proper wire connections and grounding. Retest.</i>

SYMPTOM	HEADLAMP DIMING.
CONDITION	NORMAL USE.
Test/Inspection	<b>1. Check voltage at headlamp at different speeds. It must not be below 11 Vac.</b> a. Insufficient voltage in lighting circuit. <i>Replace voltage regulator and retest.</i> b. Wires are worn or loose. <i>Ensure proper wire connections and grounding. Retest.</i>
Test/Inspection	<b>2. Visually inspect wiring harness for damaged and/or melted wires and/or bad wire terminal crimping and/or connections.</b> a. Heating, rotating or sharp part in contact with harness. Improper harness routing. <i>Repair/replace damaged wires and/or terminals. Reroute harness where necessary.</i>



## Section 03 TROUBLESHOOTING

### Subsection 05 (ELECTRICAL SYSTEM)

<b>SYMPTOM</b>	<b>ENGINES DOES NOT START — NO SPARK AT SPARK PLUG.</b>
<b>CONDITION</b>	AT ENGINE CRANKING.
<b>Test/Inspection</b>	<b>1. Verify spark plug condition.</b> a. Defective, improperly set, worn-out, fouled. <i>Identify source of problem and correct. Replace spark plug.</i>
	<b>2. Verify spark plug cap resistance with an ohmmeter.</b> a. Defective part. <i>Replace cap.</i>
	<b>3. Verify if problem originated from electrical system wiring harness and/or accessories and/or ignition cut-out switches. Check condition of connectors.</b> a. Heating, rotating or sharp part in contact with harness. Improper harness routing. Defective switch(es). Corroded connector terminals. <i>Replace or repair damaged wires. Reroute where necessary. Replace defective switch(es). Clean terminals and apply silicone dielectric grease.</i>
	<b>4. Verify ignition coil resistance with an ohmmeter and connector condition.</b> a. Defective coil. Corroded connector terminals. <i>Replace defective coil. Clean terminals and apply silicone dielectric grease.</i>
	<b>5. Verify condition of ignition coil.</b> a. Mechanically damaged part. Vibration problem. Electrically damaged part. <i>Tighten mounting screws. Replace ignition coil.</i>
	<b>6. Verify condition of ignition generator coils.</b> a. Mechanically damaged part. Vibration problem. Electrically damaged part. <i>Tighten mounting screws. Replace coils.</i>

<b>SYMPTOM</b>	<b>ENGINE STALLS.</b>
<b>CONDITION</b>	AT LOW SPEED.
<b>Test/Inspection</b>	<b>1. Verify items 4, 5 and 6 above.</b>

<b>SYMPTOM</b>	<b>IRREGULAR ENGINE SPEED.</b>
<b>CONDITION</b>	AT HIGH SPEED.
<b>Test/Inspection</b>	<b>1. Verify items 3, 4, 5 and 6 above.</b>
<b>CONDITION</b>	AT LOW SPEED.
<b>Test/Inspection</b>	<b>1. Verify items 3, 4 and 5 above and ignition coil/flywheel protrusion air-gap.</b> a. Air-gap too large. <i>Readjust air-gap.</i>

**Section 03 TROUBLESHOOTING**  
Subsection 05 (ELECTRICAL SYSTEM)

<b>SYMPTOM</b>	<b>ENGINE IS MISFIRING — ERRATIC SPARK AT SPARK PLUG.</b>
<b>CONDITION</b>	RIDING ON WET SNOW.
<b>Test/Inspection</b>	<p><b>1. Verify if spark plug wires and/or spark plug cap seals are sealing-out moisture.</b></p> <p>a. Defective wires and/or seals. <i>Replace defective part.</i></p> <p><b>2. Verify if ignition system wiring harness connectors are in good condition and/or are sealing-out moisture.</b></p> <p>a. Loose connectors, corroded terminals or defective parts. <i>Clean terminals and apply silicone dielectric grease. Replace defective parts.</i></p>
<b>CONDITION</b>	RIDING IN DEEP AND THICK SNOW.
<b>Test/Inspection</b>	<p><b>1. Perform all verifications outlined under “Engine does not start — no spark at spark plug”.</b></p> <p><b>2. Verify spark plug. Proceed with spark plug analysis in order to identify source of problem.</b></p> <p>a. Defective and/or worn spark plug(s) and/or cable(s) and/or cap(s). <i>Replace defective part(s). Proceed with ignition system testing procedures. Perform engine analysis.</i></p>

<b>SYMPTOM</b>	<b>FOULED (BLACK) SPARK PLUG TIP.</b>
<b>CONDITION</b>	NORMAL USE.
<b>Test/Inspection</b>	<p><b>1. Check carburetor.</b></p> <p>a. Carburation is too rich. <i>Adjust according to specifications (refer to TECHNICAL DATA 10).</i></p> <p><b>2. Check engine compression.</b></p> <p>a. Leaking piston ring(s). <i>Replace.</i></p>

<b>SYMPTOM</b>	<b>SPARK PLUG TIP IS LIGHT GREY.</b>
<b>CONDITION</b>	NORMAL USE.
<b>Test/Inspection</b>	<p><b>1. Refer to “Engine slows down or stops at high RPM” and check items listed.</b></p> <p><b>2. Check spark plug heat range.</b></p> <p>a. Spark plug heat range is too high. <i>Replace by Bombardier’s recommended spark plug (refer to ELECTRICAL 06).</i></p> <p><b>3. Check carburetor gasket.</b></p> <p>a. Cracked or deformed gasket. <i>Replace.</i></p>

---

## Section 03 TROUBLESHOOTING

### Subsection 05 (ELECTRICAL SYSTEM)

---

<b>SYMPTOM</b>	<b>REAR LIGHT BULB FLASHES.</b>
<b>CONDITION</b>	NORMAL USE.
<b>Test/Inspection</b>	<b>1. Check if rear light is properly connected.</b> a. Connector housing is partially connected. <i>Install connector housing properly.</i>
	<b>2. Check continuity of wires.</b> a. Corroded terminals and/or broken wires. <i>Replace terminal(s) or crimp defective wires.</i>

# SUSPENSION AND TRACK

The following chart is provided to help in diagnosing the probable source of troubles. It should be used as a guideline.

<b>SYMPTOM</b>	<b>REAR SUSPENSION BOTTOMS OUT.</b>
CONDITION	NORMAL USE.
Test/Inspection	<b>1. Check rear spring preload.</b> a. Spring tension is too low. <i>Replace spring.</i>

<b>SYMPTOM</b>	<b>SLIDER SHOES WEAR OUT PREMATURELY.</b>
CONDITION	NORMAL USE.
Test/Inspection	<b>1. Check track tension.</b> a. Pressure is too great on slider shoes. <i>Adjust according to specifications (refer to TECHNICAL DATA 10). Replace defective parts.</i>

<b>SYMPTOM</b>	<b>PREMATURE WEAR ON TRACK GUIDES.</b>
CONDITION	NORMAL USE.
Test/Inspection	<b>1. Check track tension.</b> a. Pressure is too great on guides. <i>Adjust according to specifications (refer to TECHNICAL DATA 10).</i>  <b>2. Check slider shoes and/or suspension retaining screws.</b> a. Worn slider shoes or lost retaining screws. <i>Replace defective parts and/or tighten loose screws.</i>

<b>SYMPTOM</b>	<b>NOISE OR VIBRATIONS ORIGINATING FROM THE TRACK.</b>
CONDITION	NORMAL USE.
Test/Inspection	<b>1. Check slide suspension retaining bolts.</b> a. Missing bolt(s) allowing movement of certain components which in turn interfere with track rotation. <i>Replace missing bolt(s).</i>  <b>2. Check condition of idler wheel(s).</b> a. Idler wheel rubber is damaged. <i>Replace.</i>  <b>3. Check sprockets.</b> a. One or various teeth of drive shaft sprockets are broken. <i>Replace sprocket(s).</i>  <b>4. Check track internal traction teeth.</b> a. One or various track teeth are broken. <i>Replace track.</i>

## Section 03 TROUBLESHOOTING

### Subsection 06 (SUSPENSION AND TRACK)

<b>SYMPTOM</b>	<b>DERAILING TRACK.</b>
<b>CONDITION</b>	NORMAL USE.
<b>Test/Inspection</b>	<b>1. Check track tension.</b> a. Track is too loose. <i>Adjust.</i>
	<b>2. Check if track and slider shoes are properly aligned.</b> a. Improper alignment. <i>Adjust.</i>
	<b>3. Check slide suspension retaining bolts.</b> a. Missing bolt(s) allowing movement of certain components which in turn interfere with track rotation. <i>Replace missing bolt(s).</i>

<b>SYMPTOM</b>	<b>REAR SUSPENSION IS LOW OR TOO STIFF.</b>
<b>CONDITION</b>	NORMAL USE.
<b>Test/Inspection</b>	<b>1. Check track tension.</b> a. Track is too tight. <i>Adjust.</i>
	<b>2. Check if axles are properly lubricated.</b> a. Improper lubrication and/or contaminated grease (sticky oil sludge). <i>Clean and/or lubricate.</i>
	<b>3. Check rear spring preload.</b> a. Insufficient preload. <i>Replace rear spring.</i>

<b>SYMPTOM</b>	<b>WHEN HANDLEBAR IS TURNED, SNOWMOBILE UNDERSTEERS.</b>
<b>CONDITION</b>	NORMAL USE.
<b>Test/Inspection</b>	<b>1. Check ski runner condition.</b> a. Worn ski runners. <i>Replace.</i>
	<b>2. Check if front arm stopper strap is too long.</b> a. Insufficient ski pressure on the ground. <i>Replace front arm stopper strap.</i>

**Section 03 TROUBLESHOOTING**  
Subsection 06 (SUSPENSION AND TRACK)

<b>SYMPTOM</b>	<b>HANDLE BAR IS DIFFICULT TO TURN.</b>
<b>CONDITION</b>	NORMAL USE.
<b>Test/Inspection</b>	<p><b>1. Check condition of ball joints.</b></p> <p>a. Corrosion restrains movement. <i>Lubricate or replace.</i></p> <p><b>2. Check U-clamp and retaining support</b></p> <p>a. Torque on screws are too high. <i>Refer to STEERING/FRONT SUSPENSION 08.</i></p> <p>b. Grease missing. <i>Apply lithium grease on steering column bushings.</i></p>

<b>SYMPTOM</b>	<b>THE SNOWMOBILE IS UNSTABLE (IT MOVES FROM LEFT TO RIGHT AND VICE VERSA).</b>
<b>CONDITION</b>	NORMAL USE.
<b>Test/Inspection</b>	<p><b>1. Check ski runner condition.</b></p> <p>a. Worn or bent ski runners. <i>Replace ski runners.</i></p> <p><b>2. Check ski alignment.</b></p> <p>a. Improper ski alignment. <i>Align skis in order to obtain proper toe-out (opening) (to adjust, refer to STEERING/FRONT SUSPENSION 08).</i></p> <p><b>3. Check if bushings are too loose in steering system.</b></p> <p>a. Bushings are too loose. <i>Replace.</i></p>

# TABLE OF CONTENTS

<b>ENGINE REMOVAL AND INSTALLATION</b> .....	<b>04-02-1</b>
REMOVAL FROM VEHICLE .....	04-02-2
ENGINE AND MUFFLER DISASSEMBLY AND ASSEMBLY.....	04-02-2
INSTALLATION ON VEHICLE .....	04-02-2
<b>VALVE ADJUSTMENT</b> .....	<b>04-03-1</b>
VALVE ADJUSTMENT .....	04-03-2
<b>DISASSEMBLY/ASSEMBLY</b> .....	<b>04-04-1</b>
<b>TOP END</b> .....	<b>04-04-1</b>
TOP END REMOVAL.....	04-04-2
CLEANING .....	04-04-2
DISASSEMBLY.....	04-04-2
INSPECTION .....	04-04-3
ASSEMBLY.....	04-04-3
TOP END INSTALLATION.....	04-04-4
<b>BOTTOM END</b> .....	<b>04-04-5</b>
CLEANING .....	04-04-6
DISASSEMBLY.....	04-04-6
INSPECTION .....	04-04-8
ASSEMBLY.....	04-04-8
<b>COMPRESSION TEST AND ENGINE DIMENSION MEASUREMENT</b> .....	<b>04-05-1</b>
<b>COMPRESSION TEST</b> .....	<b>04-05-1</b>
<b>ENGINE DIMENSION MEASUREMENT</b> .....	<b>04-05-2</b>
VALVE SPRING FREE LENGTH .....	04-05-2
VALVE SEAT WIDTH .....	04-05-2
VALVE STEM (outside diameter) .....	04-05-2
VALVE GUIDE (inside diameter) .....	04-05-2
GUIDE-TO-STEM CLEARANCE.....	04-05-3
CYLINDER HEAD SURFACE .....	04-05-3
CYLINDER INSIDE DIAMETER.....	04-05-3
USED PISTON MEASUREMENT .....	04-05-3
CYLINDER/PISTON CLEARANCE .....	04-05-4
RING/PISTON GROOVE CLEARANCE.....	04-05-5
RING END GAP .....	04-05-5
CONNECTING ROD BIG END SIDE CLEARANCE.....	04-05-5
PISTON PIN (outside diameter).....	04-05-6
PISTON PIN BORE (inside diameter) .....	04-05-6
PISTON-TO-PISTON PIN BORE CLEARANCE.....	04-05-6
CONNECTING ROD SMALL END (inside diameter) .....	04-05-6
CONNECTING ROD BIG END (inside diameter).....	04-05-6

---

## Section 04 ENGINE

### Subsection 01 (TABLE OF CONTENTS)

---

CAMSHAFT (OUTSIDE DIAMETER).....	04-05-8
CAMSHAFT HOLDER (INSIDE DIAMETER) .....	04-05-9
CHECKING SURFACE FLATNESS .....	04-05-9
RECTIFYING SURFACES.....	04-05-9
<hr/>	
<b>TRANSISTORIZED MAGNETO IGNITION.....</b>	<b>04-06-1</b>
CLEANING .....	04-06-2
DISASSEMBLY .....	04-06-2
INSPECTION .....	04-06-2
ASSEMBLY .....	04-06-3
<hr/>	
<b>REWIND STARTER.....</b>	<b>04-07-1</b>
REMOVAL .....	04-07-2
DISASSEMBLY .....	04-07-2
INSPECTION .....	04-07-3
ASSEMBLY .....	04-07-3
INSTALLATION .....	04-07-5
<hr/>	
<b>CARBURETOR.....</b>	<b>04-08-1</b>
REMOVAL .....	04-08-2
CLEANING AND INSPECTION .....	04-08-4
DISASSEMBLY AND ASSEMBLY .....	04-08-4
CARBURETOR FLOAT LEVEL .....	04-08-6
INSTALLATION .....	04-08-6
CARBURETOR ADJUSTMENTS.....	04-08-7
GOVERNOR ADJUSTMENT .....	04-08-7
<hr/>	
<b>FUEL TANK AND THROTTLE CABLE.....</b>	<b>04-09-1</b>



# ENGINE REMOVAL AND INSTALLATION

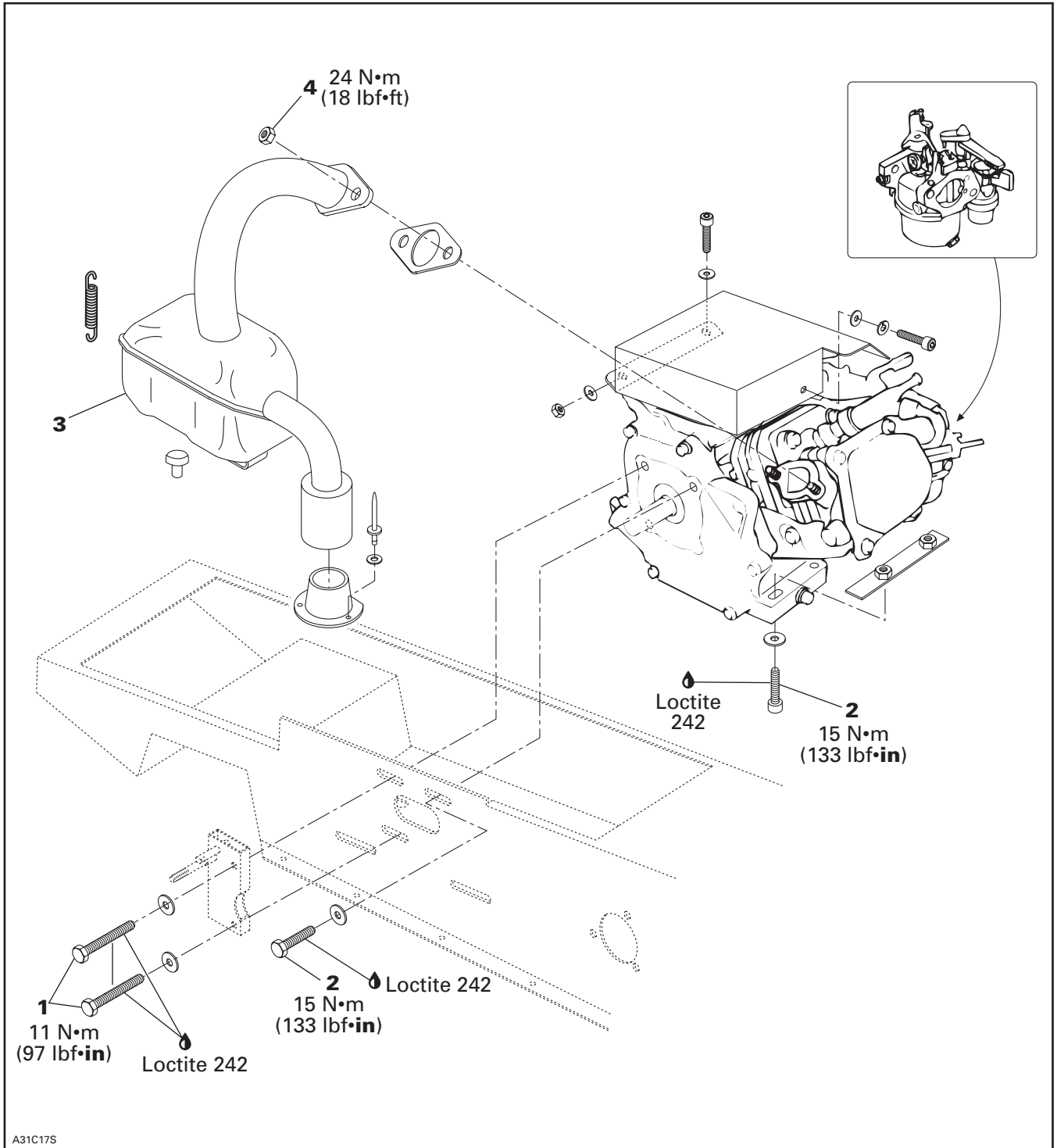

A31C17S

---

## Section 04 ENGINE

### Subsection 02 (ENGINE REMOVAL AND INSTALLATION)

---

## REMOVAL FROM VEHICLE

Remove or disconnect the following then lift engine from vehicle:

- chain guard
- drive chain
- drive sprocket (clutch)
- muffler **no. 3**
- throttle cable
- choke cable
- fuel line
- electrical connectors
- engine mount screws **no. 2**
- brake support screws **no. 1**

## ENGINE AND MUFFLER DISASSEMBLY AND ASSEMBLY

Torque the muffler nuts **no. 4** to 24 N•m (18 lbf•ft).

Torque both brake support screws **no. 1** to 11 N•m (97 lbf•in) and 5 engine mount screws **no. 2** to 15 N•m (133 lbf•in).

## INSTALLATION ON VEHICLE

To install engine on vehicle, reverse removal procedure. However, pay attention to the following:

- Check tightness of engine mount screws, and clutch screw.
- After throttle cable and choke installation, check for proper operation.
- Check drive chain automatic tensioner for proper operation.

# VALVE ADJUSTMENT

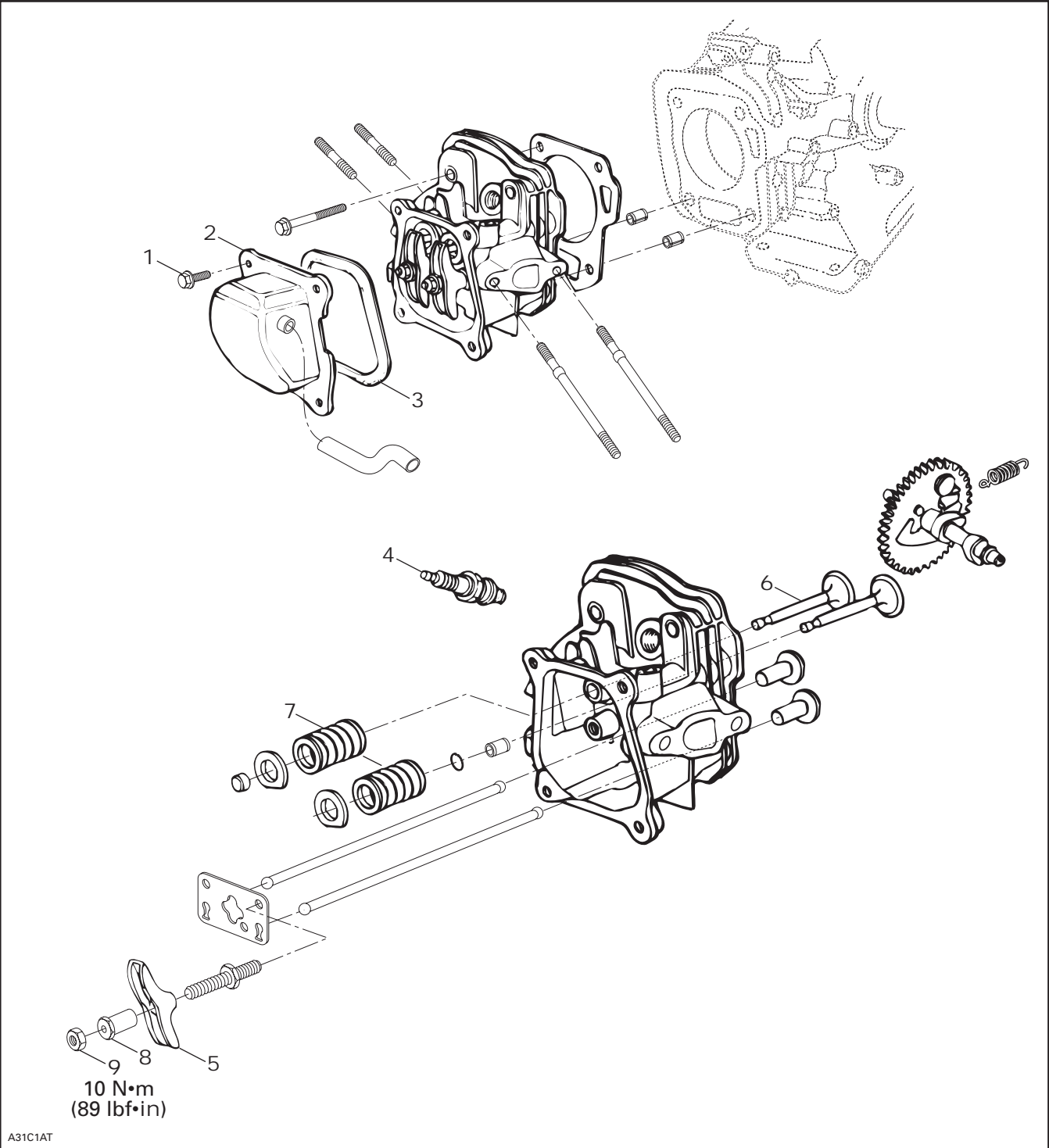

## VALVE ADJUSTMENT

**NOTE:** Valve clearance inspection and adjustment must be performed with the engine cold.

### Preparation

Remove cylinder head cover bolts **no. 1**, cylinder head cover **no. 2** and gasket **no. 3**.

Set the piston at TDC (Top Dead Center) of the **compression** stroke, as shown in the following procedure.

### COMPRESSION STROKE TDC POSITIONING

Remove spark plug **no. 4**.

Turn engine clockwise (PTO side) by hand so that triangular mark on starter pulley align with the top hole on the fan cover.

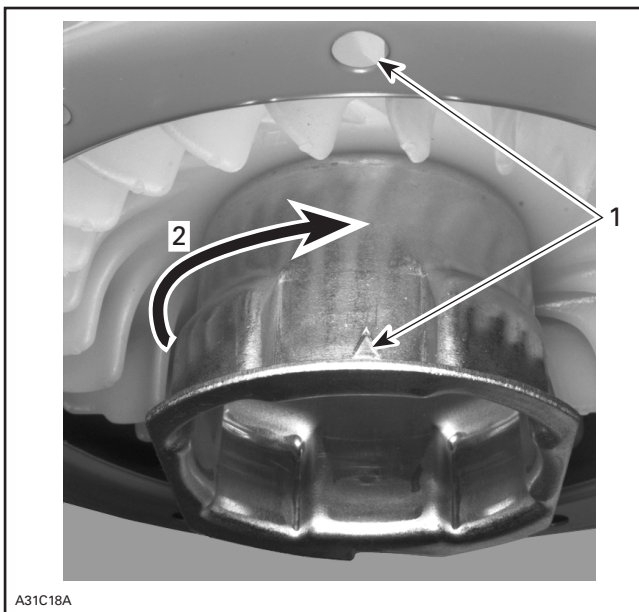

**REWIND STARTER HAS BEEN REMOVED**

1. Triangular mark aligned with fan cover top hole
2. Rotate clockwise to position engine at TDC of compression stroke

### ▼ CAUTION

The triangular mark on the starter pulley will align with the top hole on the fan cover when the piston is at top dead center of the compression or exhaust stroke. Ensure that piston is at TDC of the **compression** stroke. At compression stroke both valves are fully closed.

## Valve Clearance Inspection

Insert a feeler gauge between rocker arm **no. 5** and valve **no. 6**. Refer to the following table for valve clearance.

STANDARD VALVE CLEARANCE	
Intake valve	0.15 ± 0.02 mm (0.006 ± 0.001 in)
Exhaust valve	0.20 ± 0.02 mm (0.008 ± 0.001 in)

**NOTE:** When inspecting clearance, ensure that feeler gauge does not compress valve springs **no. 7**. Valve springs have low compression rates. If valve clearance is not according to the above table, perform valve clearance adjustment as described in the following procedure.

## Valve Clearance Adjustment

Hold rocker arm pivot **no. 8** and loosen rocker arm pivot lock nut **no. 9**, as shown in the next photo.

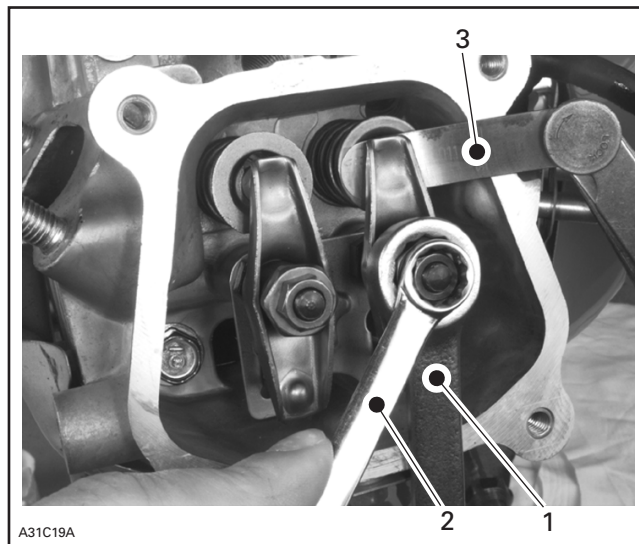

1. Tool retaining rocker arm pivot
2. Tool loosening lock nut of rocker arm pivot
3. Feeler gauge

Turn rocker arm pivot to obtain the specified clearance.

Retighten the rocker arm pivot lock nut while holding the rocker arm pivot.

Recheck valve clearance after tightening the rocker arm pivot lock nut.

Reinstall cylinder head cover with gasket then secure with cylinder head cover bolts in a crisscross sequence.

# DISASSEMBLY/ASSEMBLY

## TOP END

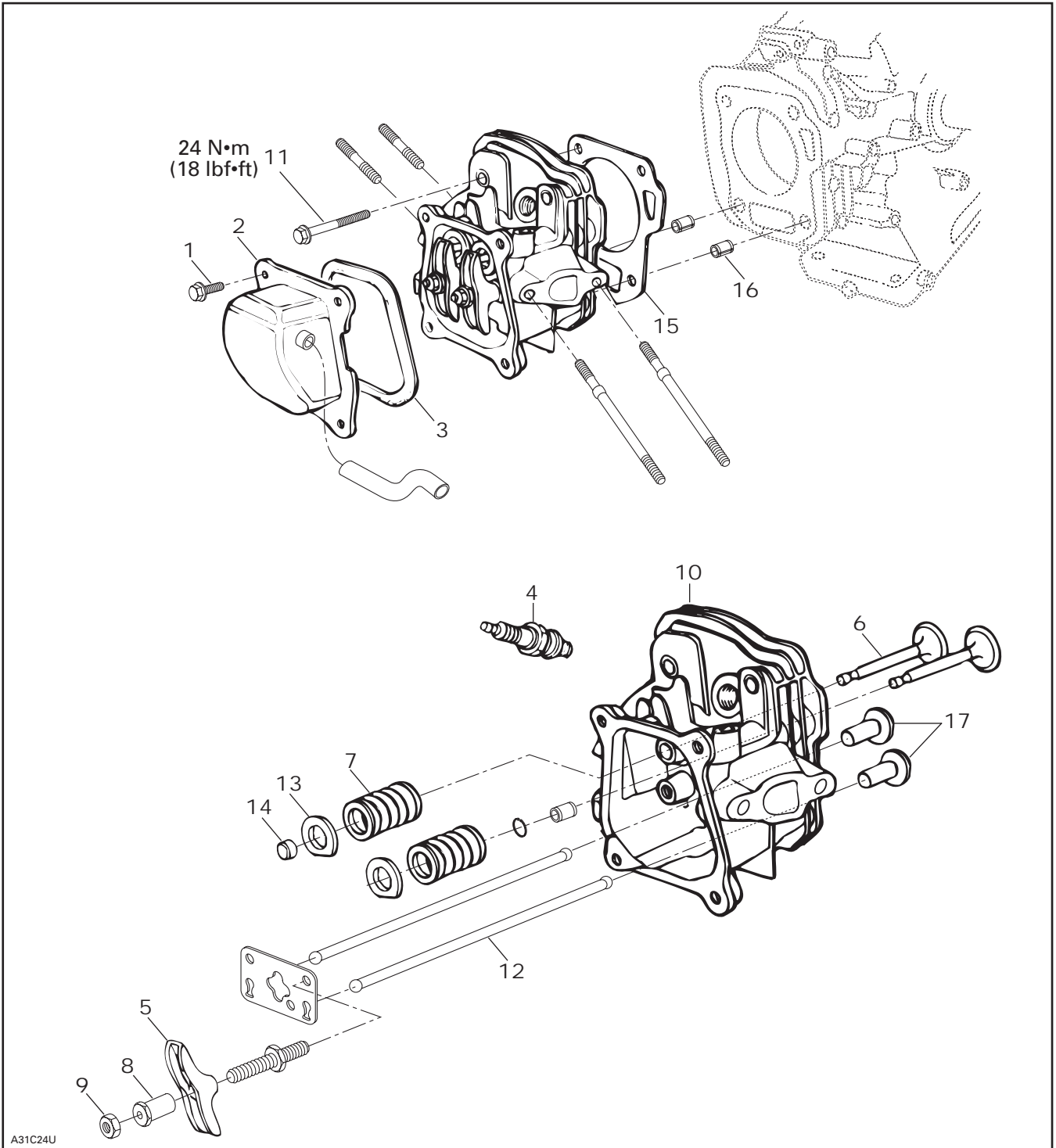

## Section 04 ENGINE

### Subsection 04 (DISASSEMBLY/ASSEMBLY)

## TOP END REMOVAL

Remove the following then lift cylinder head **no. 10**:

- carburetor
- exhaust system
- spark plug **no. 4**
- cylinder head cover **no. 2**
- cylinder head nuts **no. 11**

**NOTE:** When removing cylinder head, mark both push rods **no. 12** for reassembly.

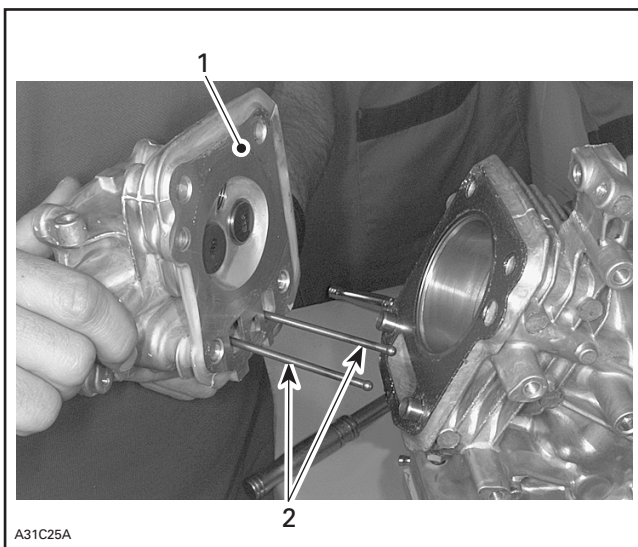

TYPICAL — MECHANIC REMOVING CYLINDER HEAD

1. Cylinder head
2. Mark both push rods for reassembly

Pull out push rods.

## CLEANING

Discard all gaskets.

Clean all metal components in a non-ferrous metal cleaner.

Scrape off carbon formation from cylinder exhaust port, cylinder head, valves **no. 6** and piston dome using a wooden spatula.

**NOTE:** The triangular mark on the piston dome must be visible after cleaning.

Clean the piston ring grooves with a groove cleaner tool, or with a piece of broken ring.

## DISASSEMBLY

**NOTE:** Before disassembling, mark valve springs **no. 7**, valves **no. 6** and rocker arms **no. 5**. This will ensure that parts will not be inverse at reassembly.

Unscrew rocker arm pivot lock nuts **no. 9** and rocker arm pivots **no. 8**. Remove them.

Remove both rocker arms **no. 5**.

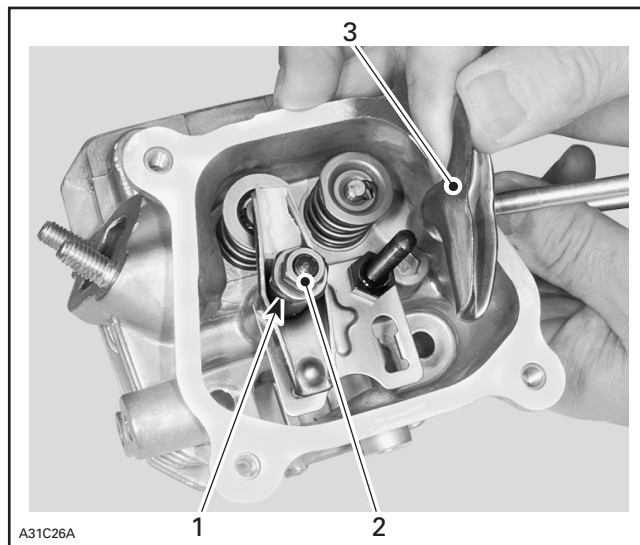

TYPICAL — MECHANIC REMOVING ROCKER ARM OF INTAKE VALVE

1. Rocker arm pivot
2. Rocker arm pivot lock nut
3. Rocker arm

Push down and slide the spring retainer **no. 13** to the side, so the valve stem slips through the hole, as shown in the next photo.



TYPICAL — PUSH DOWN AND SLIDE RETAINER TO THE SIDE

Put apart valve spring retainer and spring.

Repeat procedure for exhaust valve but ensure that valve rotator no. 14 is removed first. Refer to the following photo.

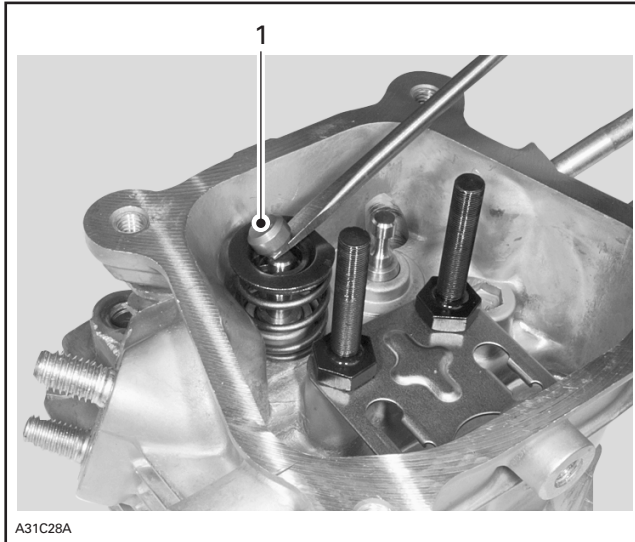

1. On exhaust valve only, remove valve rotator then remove valve spring retainer

Pull out both valves from cylinder head.

## INSPECTION

Refer to COMPRESSION TEST AND ENGINE DIMENSIONS MEASUREMENT 04-05.

## ASSEMBLY

Slide exhaust valve (small diameter) into exhaust valve guide, then slide intake valve (large diameter) into intake guide. See next photo.

Install springs and secure with valve spring retainers.

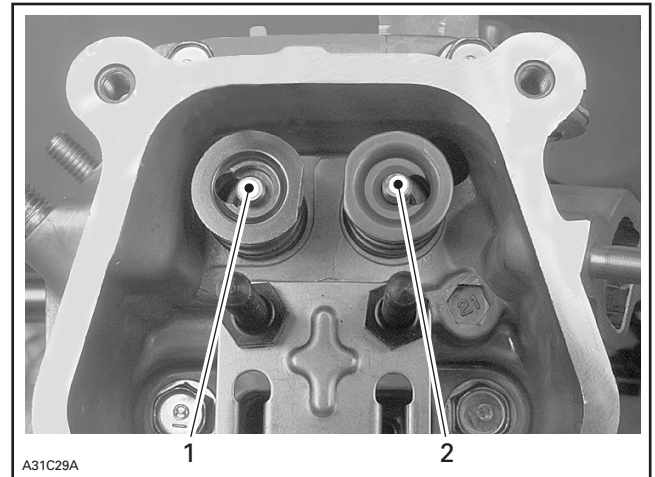

### EXHAUST AND INTAKE VALVES SECURED IN PLACE

1. Exhaust valve (small dia.) location
2. Intake valve (large dia.) location

Install valve rotator on exhaust valve.

## ▼ CAUTION

To avoid engine damage, ensure that exhaust valve rotator is properly installed on exhaust valve, as shown in the next photo.

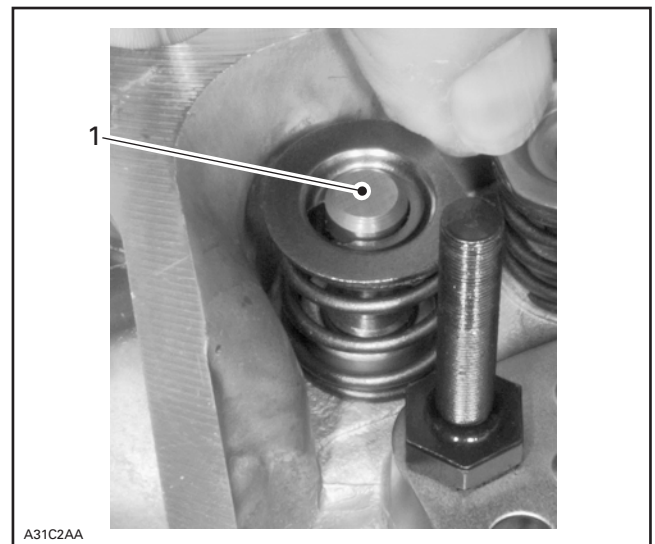

### EXHAUST VALVE SHOWN

1. Exhaust valve rotator in place

---

## Section 04 ENGINE

### Subsection 04 (DISASSEMBLY/ASSEMBLY)

---

## TOP END INSTALLATION

Install cylinder head gasket no. 15 and check that both locating pins no. 16 are in place, as shown in the next photo.

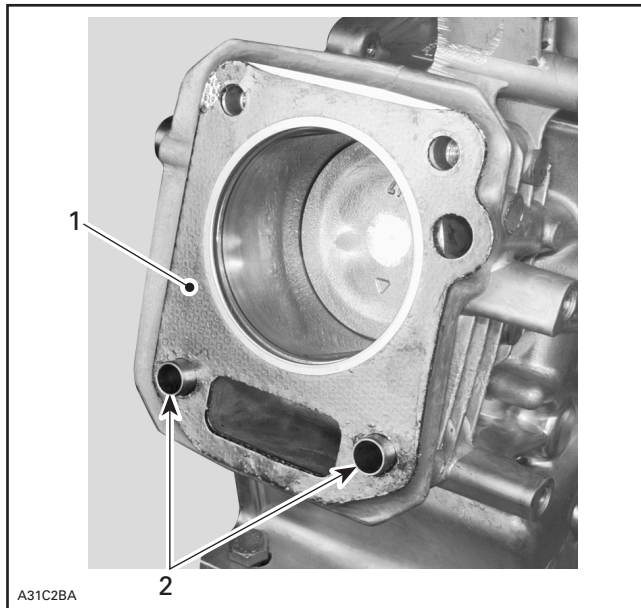

1. Cylinder head gasket
2. Locating pin

Check push rods no. 12 on both ends for wear. Check also push rods for straightness.

Install push rod ends into lifters no. 17.

Reinstall cylinder head.

### ▼ CAUTION

Ensure that push rods are properly inserted into push rod guides and firmly seated in the lifters.

Secure cylinder head with screws.

Reinstall cylinder head cover.



**BOTTOM END**

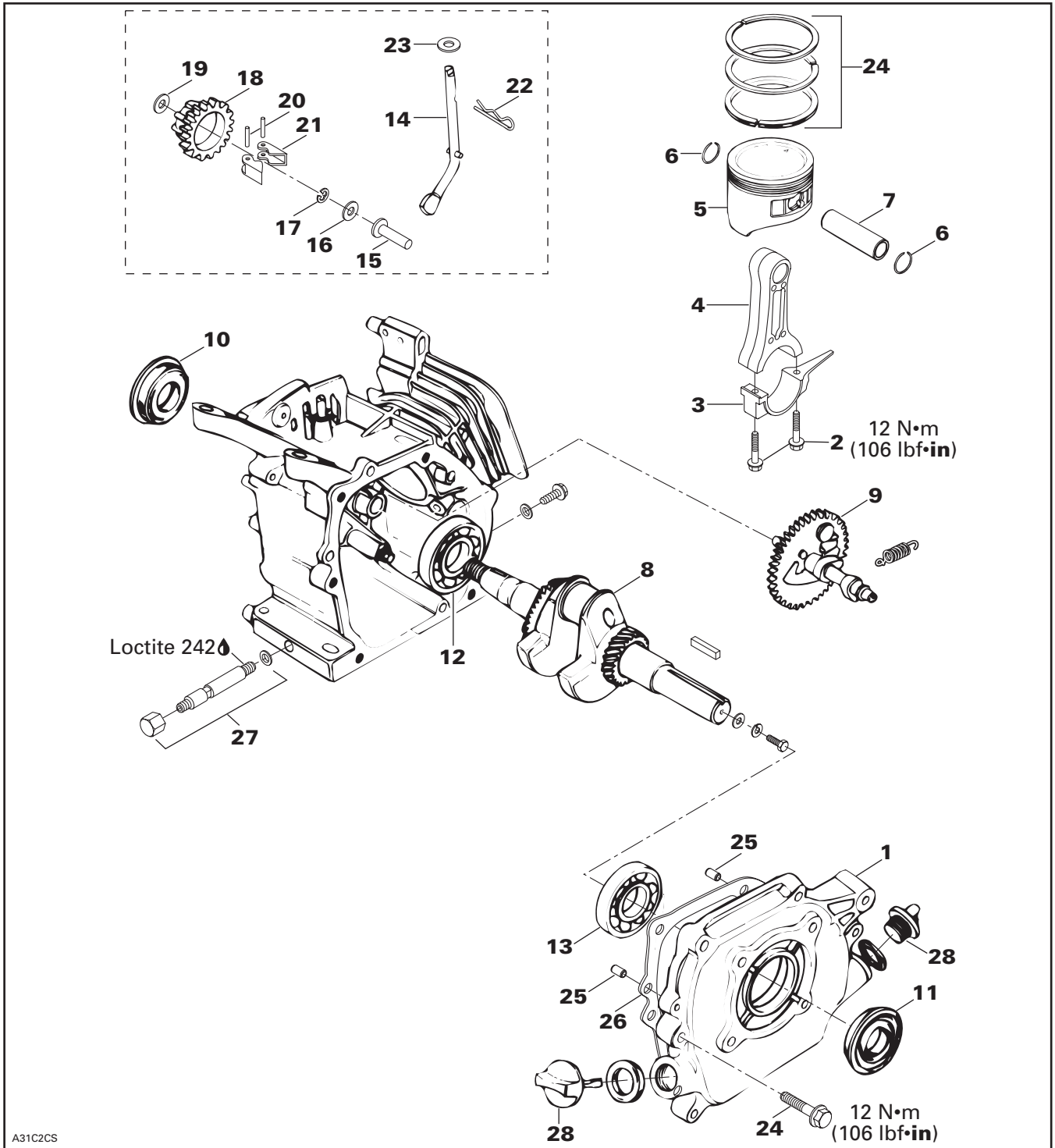

## Section 04 ENGINE

### Subsection 04 (DISASSEMBLY/ASSEMBLY)

**NOTE:** Engine must be removed from chassis to perform the following procedures.

## CLEANING

Discard all oil seals and gaskets.

Clean all metal components in a non-ferrous metal cleaner.

## DISASSEMBLY

### General

To remove clutch, refer to CLUTCH 05-02.

To remove magneto, refer to TRANSISTORIZED MAGNETO IGNITION 04-06.

### Crankcase

Drain all oil from engine base.

Remove crankcase cover **no. 1** on PTO side.

From inside crankcase, loosen both connecting rod screws **no. 2** then remove connecting rod cap **no. 3**.

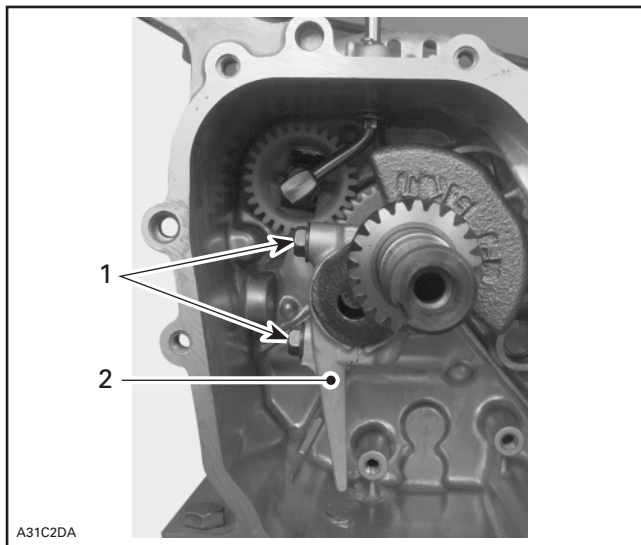

1. Connecting rod screws
2. Connecting rod cap

Push on connecting rod **no. 4** and pull out piston **no. 5**.

Remove both piston pin circlips **no. 6** and push out piston pin **no. 7**.

Detach piston from connecting rod.

Remove crankshaft **no. 8** and camshaft ass'y **no. 9**.

Mark both valve lifters and remove them. This will ensure that lifters will not be inverse at reassembly.

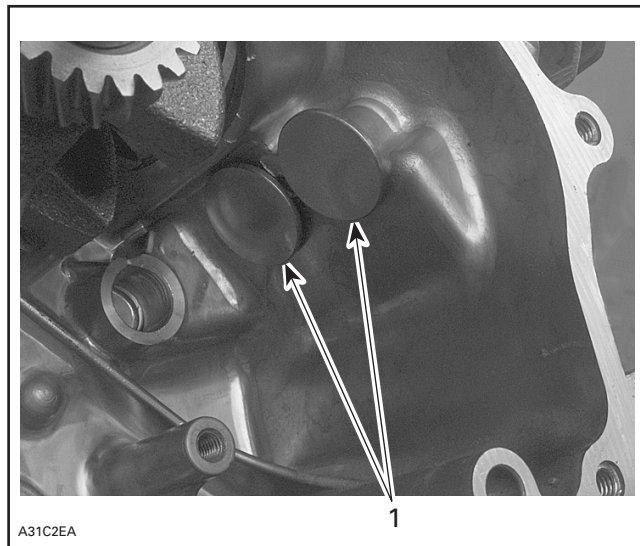

**MARK BOTH VALVE LIFTERS FOR REASSEMBLY**

1. Valve lifters

### Seals and Bearings

To remove seals **nos. 10** and **11**, push from inside crankcase towards the outside.

To remove bearings **nos. 12** and **13**, use a press with all 3 following tools:

- driver (P/N 529 035 521)
- attachment (P/N 529 035 522)
- pilot (P/N 529 035 522)

To reinstall bearings, reverse housing and use same tools as for bearings removal, as shown in the next photo.

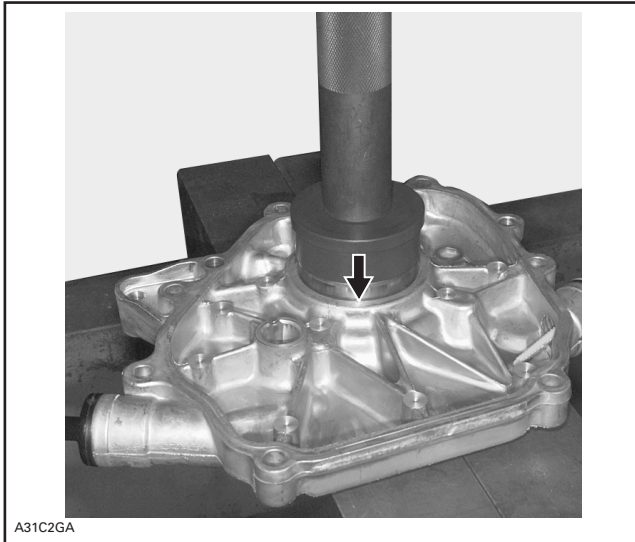

A31C2GA

**TO INSTALL BEARING**

### Governor System

Detach governor spring (black), throttle return spring and governor rod from governor arm. See next photo.

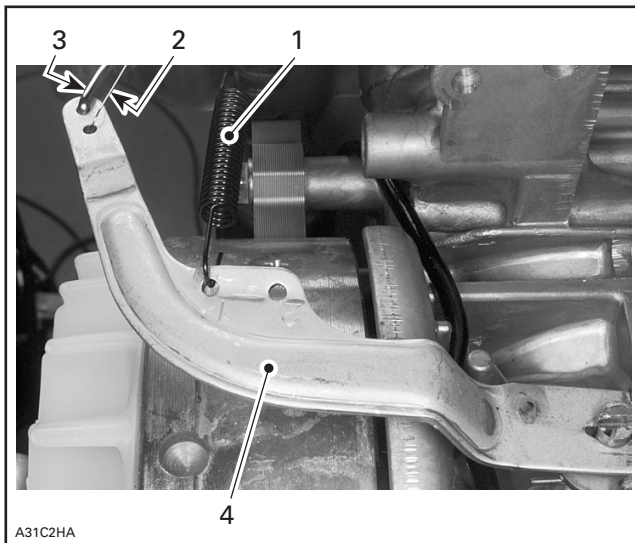

A31C2HA

1. Governor spring (black)
2. Throttle return spring
3. Governor rod
4. Governor arm

Loosen governor arm screw then remove governor arm.

From inside crankcase, rotate governor arm shaft **no. 14** then pull out governor slider **no. 15** and washer **no. 16**.

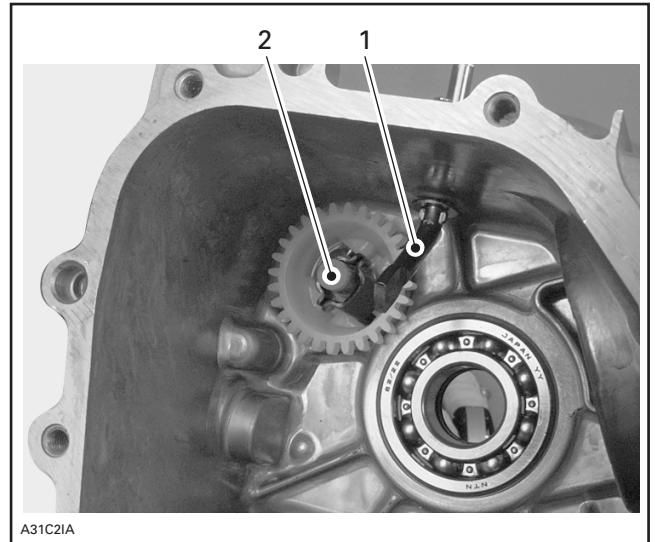

A31C2IA

1. Rotate governor arm shaft
2. Remove governor slider with washer (not shown)

Using a small flat screwdriver, remove clip **no. 17** from governor weight holder **no. 18**.

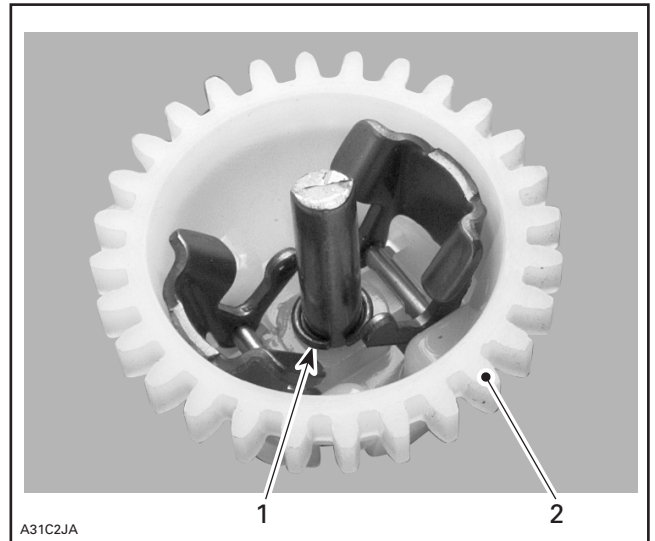

A31C2JA

**GOVERNOR ASS'Y HAS BEEN REMOVED TO SHOW CLIP**

1. Clip
2. Governor weight holder

Pull out governor weight holder and washer **no. 19**.

Remove pins **no. 20** from governor weights **no. 21** then remove governor weights.

From outside crankcase, remove lock pin **no. 22** from governor arm shaft, as shown in the next photo. Remove governor arm shaft **no. 14** with washer **no. 23**.

## Section 04 ENGINE

### Subsection 04 (DISASSEMBLY/ASSEMBLY)

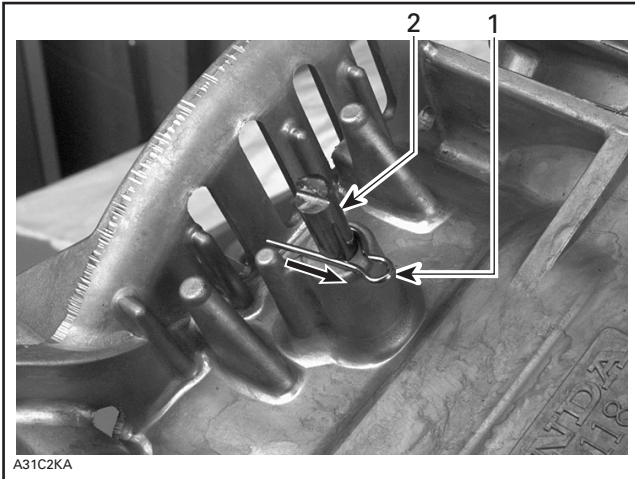

#### REMOVE LOCK PIN

1. Lock pin
2. Governor arm shaft

## INSPECTION

### Piston, Crankshaft and Camshaft

Inspect camshaft decompressor. If there is any problems, replace camshaft assembly with new one.

Refer to COMPRESSION TEST AND ENGINE DIMENSION MEASUREMENT 04-05.

### Governor System

Check for wear or damage on governor weight holder.

Check that governor weights move freely inside governor weight holder.

## ASSEMBLY

### Seals and Bearings

Using a press, install bearings nos. 12 and 13 so that they lean on crankcase flange.

### Governor System

Reinstall governor weights no. 21 with pins no. 20.

Install governor weight holder washer no. 19 then install governor weight holder no. 18 on shaft.

Secure governor weight holder with clip no. 17.

### ▼ CAUTION

Ensure that clip is properly inserted into shaft groove.

Spread governor weights no. 21 then install governor slider washer no. 16 and governor slider no. 15.

Check that governor slider moves smoothly.

Reinstall governor arm shaft no. 14 with washer no. 23 inside crankcase. Secure with lock pin no. 22.

### ▼ CAUTION

The lock pin must be installed on the governor arm shaft with the straight side of the pin against the groove in the shaft.

### Piston and Rings

Align piston mark with connecting rod long end and install piston on connecting rod. See the next illustration.

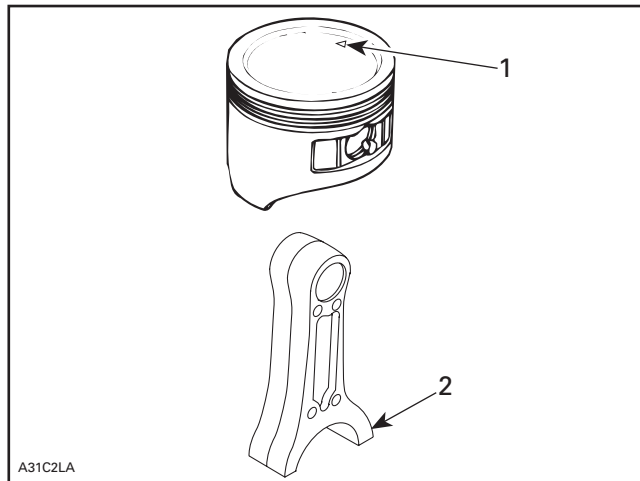

1. Piston mark
2. Connecting rod long end

Insert piston pin no. 7 into piston no. 5 and connecting rod no. 4.

Secure piston pin with both piston pin circlips no. 6.

**NOTE:** Do not align the end gap of the piston pin circlips with the cutout in the piston bore.

## Section 04 ENGINE

### Subsection 04 (DISASSEMBLY/ASSEMBLY)

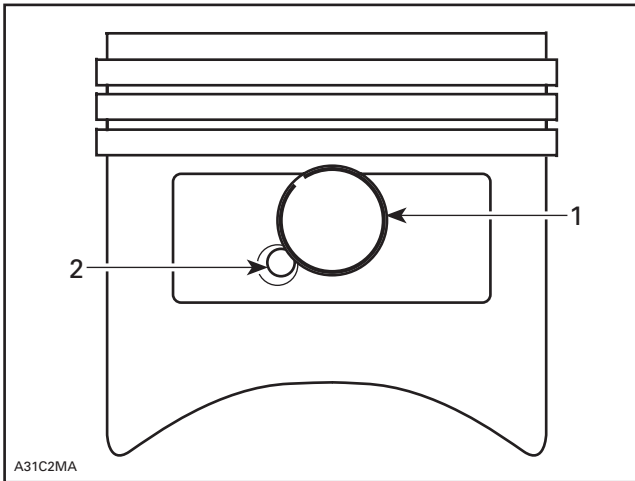

1. Piston pin circlip
2. Cutout

Install all rings **no. 24** with the markings facing upward.

Ensure that top and second rings are not interchanged.

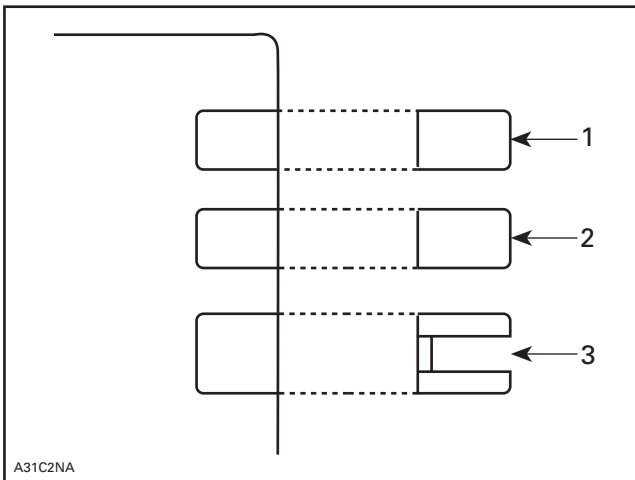

1. Top ring (chrome plated)
2. Second ring
3. Oil ring

Check that rings rotate smoothly after installation.

Space the piston ring end gaps  $120^\circ$  apart and do not align the gaps with the piston pin bore or the thrust side axis.

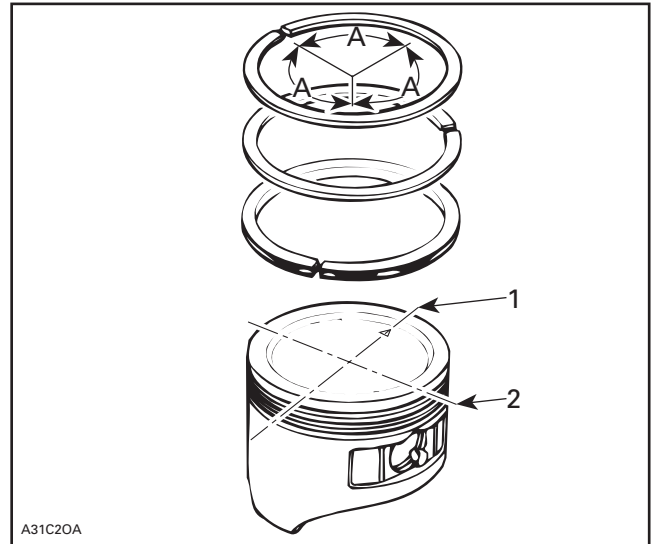

#### RING POSITIONING

1. **DO NOT** align ring gap with piston trust side axis
2. **DO NOT** align ring gap with piston pin bore axis
- A.  $120^\circ$

Position piston ass'y with piston mark toward push rod hole, as shown in the following illustration.

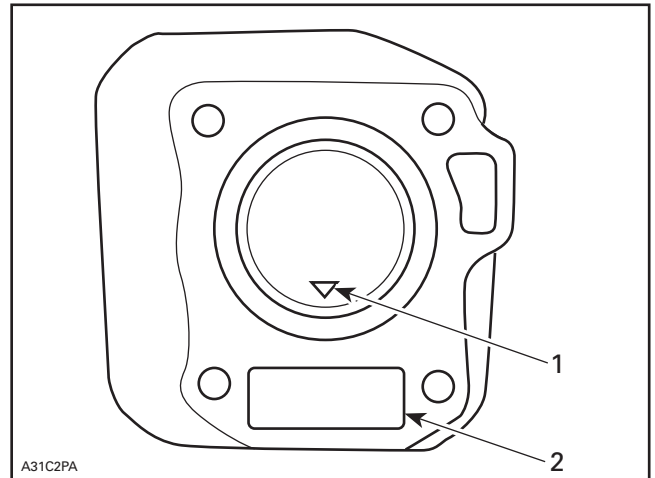

1. Piston mark
2. Push rod hole

Using a ring compressor, slide piston into cylinder with a hammer handle, as shown in the next photo.

## Section 04 ENGINE

### Subsection 04 (DISASSEMBLY/ASSEMBLY)

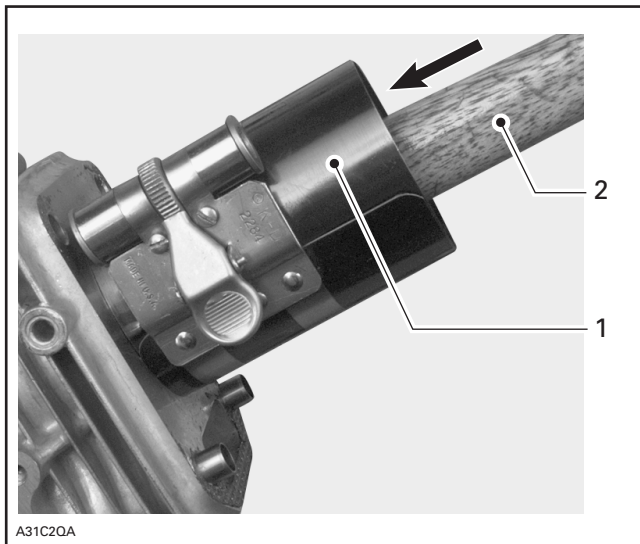

#### SLIDE PISTON INTO CYLINDER

1. Ring compressor
2. Hammer handle

## Crankshaft

Apply oil on crankshaft connecting rod location, connecting rod cap and connecting rod before starting assembly.

Install crankshaft into crankcase.

**NOTE:** To protect seal and ease crankcase cover installation, apply grease on crankcase cover seal.

Slide down piston so that connecting rod properly seats on crankshaft.

Secure connecting rod with connecting rod cap. Torque screws to 12 N•m (106 lbf•in).

### ▼ CAUTION

Ensure that connecting rod cap is properly positioned, as shown in the next photo.

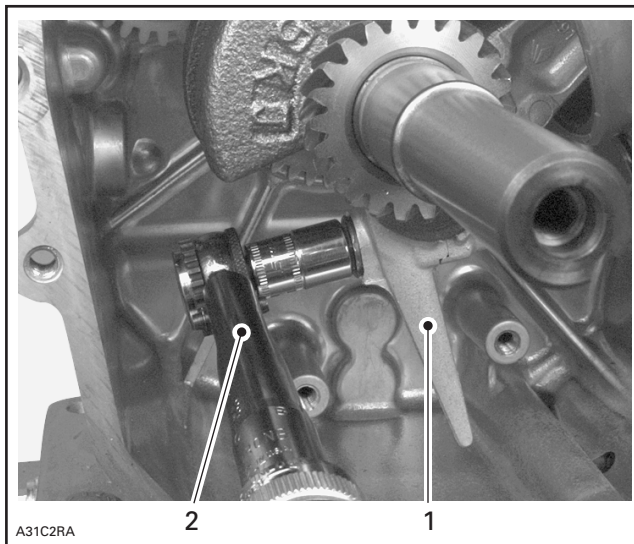

1. Connecting rod cap
2. Torque wrench

## Camshaft

Install exhaust and intake valve lifters inside crankcase.

With the crankshaft in place, align the timing punch mark of the cam gear with the punch mark of the crankshaft drive gear. Refer to the following photo.

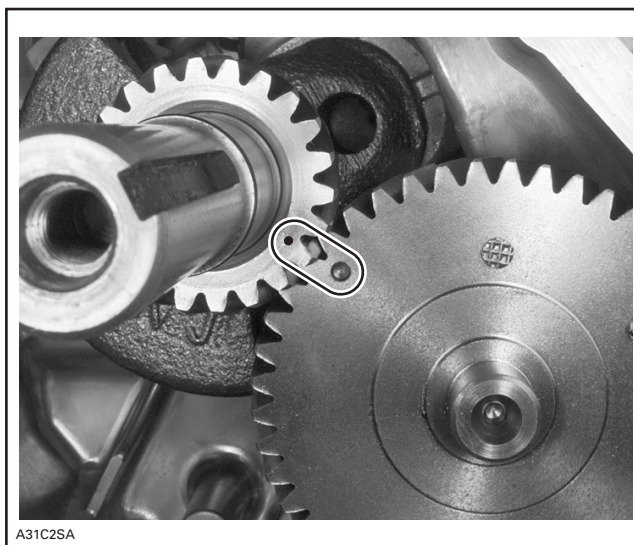

ALIGN BOTH MARKS

## Crankcase

Verify that locating sleeves **no. 25** are in place.

Install gasket **no. 26** on crankcase.

Finalize crankcase assembling with crankcase cover **no. 1**. Torque screws in a crisscross sequence to 12 N•m (106 lbf•in).

**NOTE:** To protect seal and ease crankcase cover installation, apply grease on crankcase cover seal.

Verify that oil drain bolt **no. 27** and both oil filler caps **no. 28** are in place.

# COMPRESSION TEST AND ENGINE DIMENSION MEASUREMENT

## COMPRESSION TEST

Set ignition and emergency cut-out switches to the OFF position.

Disconnect spark plug cap, then remove.

Plug compression testing gauge into spark plug hole.

Hold compression testing gauge in one hand then pull starter handle 3 or 4 times with the other hand, as shown in the next photo.

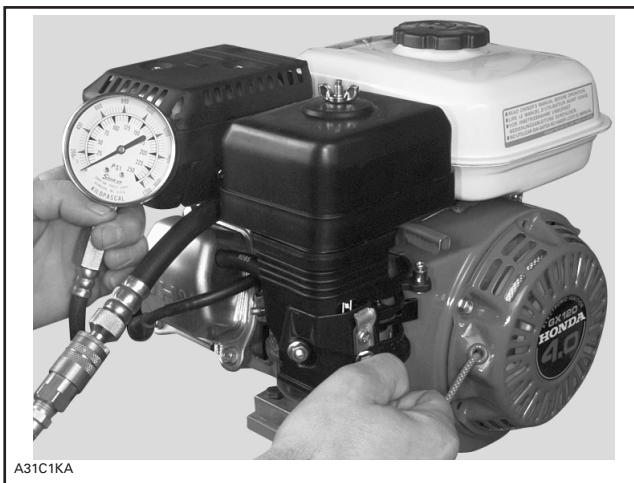

*PULL STARTER HANDLE 3 OR 4 TIMES*

Engine compression must be as described in the following table. If not, see subsection 04-03 VALVE ADJUSTMENT or subsection 04-04 DIS-ASSEMBLY/ASSEMBLY.

STANDARD	SERVICE LIMIT
110 - 120 PSI	85 PSI



## ENGINE DIMENSION MEASUREMENT

### VALVE SPRING FREE LENGTH

STANDARD	SERVICE LIMIT
30.5 mm (1.20 in)	29.5 mm (1.16 in)

Measure valve springs free length with a caliper, as shown in the next photo.

**NOTE:** When measuring free length, ensure not to apply pressure onto spring.



VALVE SPRING FREE LENGTH

If the springs are shorter than service limit value, replace with new one.

### VALVE SEAT WIDTH

STANDARD	SERVICE LIMIT
0.8 mm (0.03 in)	2.0 mm (0.08 in)

Measure valve seat width using a caliper, as shown in the next photo.



VALVE SEAT WIDTH

If valve seat width is under the standard or over the service limit value, replace cylinder head with new one.

### VALVE STEM (outside diameter)

	STANDARD	SERVICE LIMIT
INTAKE	5.48 mm (0.216 in)	5.318 mm (0.2094 in)
EXHAUST	5.44 mm (0.214 in)	5.275 mm (0.2077 in)

Measure valve stem with a micrometer, as shown in the next photo.



TYPICAL

Inspect valve surface, check for abnormal stem wear and bending. If so, replace valve with new one.

### VALVE GUIDE (inside diameter)

STANDARD	SERVICE LIMIT
5.50 mm (0.217 in)	5.572 mm (0.2194 in)

Clean valve guides to remove carbon deposits before measuring.

Measure valve guide inside diameter using a small hole telescoping gauge and a micrometer.

Replace cylinder head if valve guides are over service limit value.

### GUIDE-TO-STEM CLEARANCE

Subtract each valve stem outside diameter from the corresponding valve guide inside diameter to obtain the stem-to-guide clearance.

	STANDARD	SERVICE LIMIT
INTAKE	0.02 - 0.044 mm (0.0008 - 0.0017 in)	0.10 mm (0.004 in)
EXHAUST	0.006 - 0.087 mm (0.0024 - 0.0034 in)	0.12 mm (0.005 in)

If the stem-to-guide clearance exceeds the service limit value, replace valve or cylinder head as needed.

### CYLINDER HEAD SURFACE

SERVICE LIMIT	0.10 mm (0.004 in)
---------------	--------------------

Clean cylinder head surface.

Check cylinder head flatness with a straight edge and a feeler gauge, as shown in the next photo.

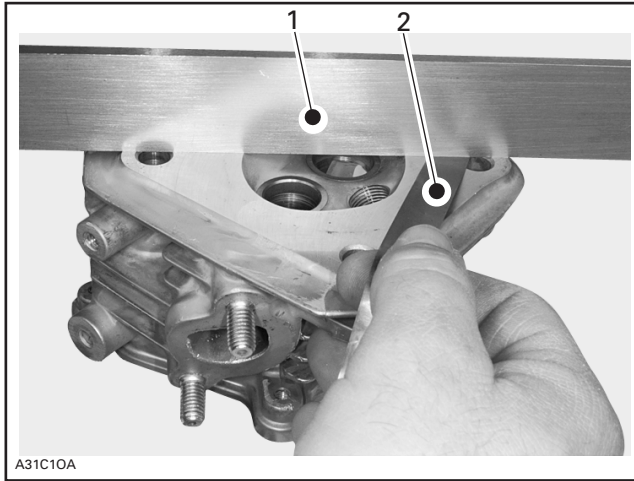

1. Straight edge
2. Feeler gauge

If cylinder head flatness is over service limit value, replace cylinder head.

### Cylinder Head Inspection

Remove carbon deposits from combustion chamber.

Check the spark plug hole and valve areas for cracks.

### CYLINDER INSIDE DIAMETER

STANDARD	SERVICE LIMIT
60.0 mm (2.36 in)	60.165 mm (2.3687 in)

Compare cylinder inside diameter 16 mm (5/8 in) from top of cylinder, halfway and 12.7 mm (1/2 in) from bottom of cylinder.

Measure cylinder inside diameter in both X (perpendicular to crankshaft) and Y (parallel to crankshaft) axis. Take the maximum reading to determine cylinder wear.

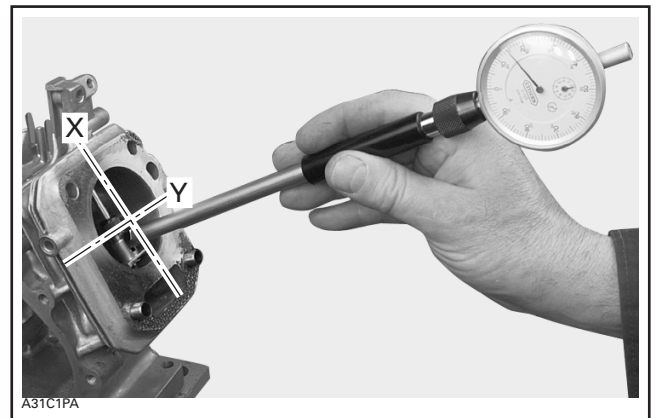

- X. Axis (perpendicular to crankshaft axis)
- Y. Axis (parallel to crankshaft axis)

If the difference exceeds the specified dimension the cylinder should be rebored and honed or should be replaced.

### USED PISTON MEASUREMENT

STANDARD	SERVICE LIMIT
59.985 mm (2.3616 in)	59.845 mm (2.3561 in)

Using a micrometer, measure piston at 10 mm (25/64 in) perpendicularly (90°) to piston pin.

## Section 04 ENGINE

### Subsection 05 (COMPRESSION TEST AND ENGINE DIMENSION MEASUREMENT)

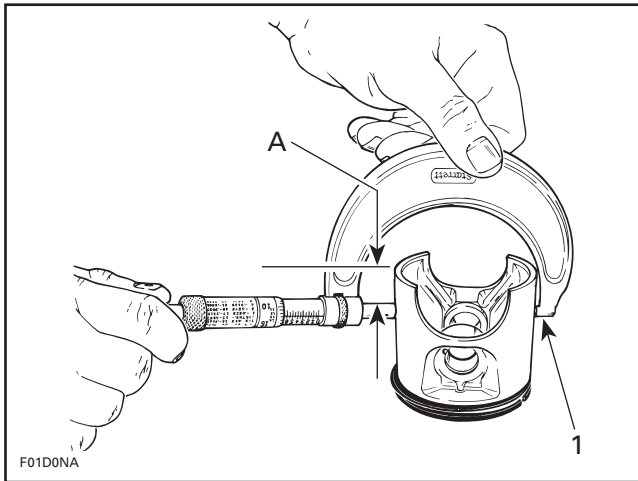

#### TYPICAL

1. Measuring perpendicularly (90°) to piston pin axis  
A. 10 mm (25/64 in)

The measured dimension should be as described in the previous table. If not, install a new piston.

## CYLINDER/PISTON CLEARANCE

STANDARD	SERVICE LIMIT
0.015 - 0.050 mm (0.0006 - 0.0020 in)	0.12 mm (0.005 in)

### Used and New Pistons

**NOTE:** Make sure used piston is not worn. See USED PISTON MEASUREMENT above.

Adjust and lock a micrometer to the piston dimension.

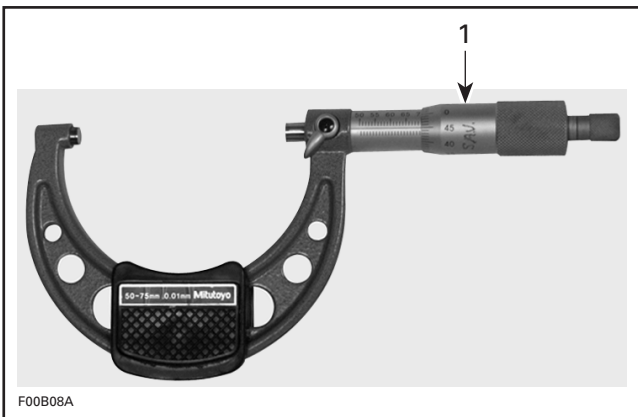

1. Micrometer set to the piston dimension

With the micrometer set to the piston dimension, adjust a cylinder bore gauge to the micrometer dimension and set the indicator to 0 (zero).

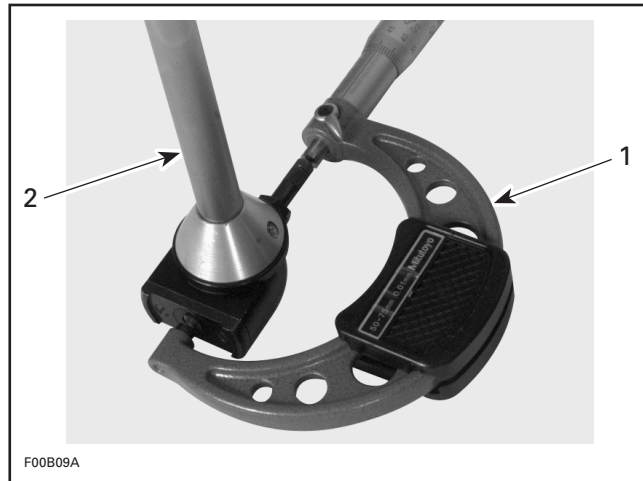

1. Use the micrometer to set the cylinder bore gauge
2. Dial bore gauge



#### TYPICAL

1. Indicator set to 0 (zero)

Position the dial bore gauge at 16 mm (5/8 in) below cylinder top edge, measuring perpendicularly (90°) to piston pin axis. See CYLINDER INSIDE DIAMETER above.

Read the measurement on the cylinder bore gauge. The result is the exact piston/cylinder wall clearance. If clearance exceeds specified tolerance, replace cylinder or rebore. See previous table.

**NOTE:** Make sure the cylinder bore gauge indicator is set exactly at the same position as with the micrometer, otherwise the reading will be false.

### RING/PISTON GROOVE CLEARANCE

STANDARD	SERVICE LIMIT
0.015 - 0.045 mm (0.0006 - 0.0018 in)	0.15 mm (0.006 in)

**NOTE:** These clearances are applicable for 3 rings; top, second and oil ring.

Using a feeler gauge check clearance between ring and groove. Replace piston if clearance exceeds specified tolerance. See above table.



RING/PISTON GROOVE CLEARANCE

### RING END GAP

	STANDARD	SERVICE LIMIT
TOP AND SECOND	0.2 - 0.4 mm (0.008 - 0.016 in)	1.0 mm (0.04 in)
OIL	0.15 - 0.35 mm (0.006 - 0.014 in)	1.0 mm (0.04 in)

Position ring 16 mm (5/8 in) from top of cylinder.

**NOTE:** In order to correctly position the ring in the cylinder, use piston as a pusher.

Using a feeler gauge, check ring end gap. Replace ring, if gap exceeds specified tolerance. See above table.

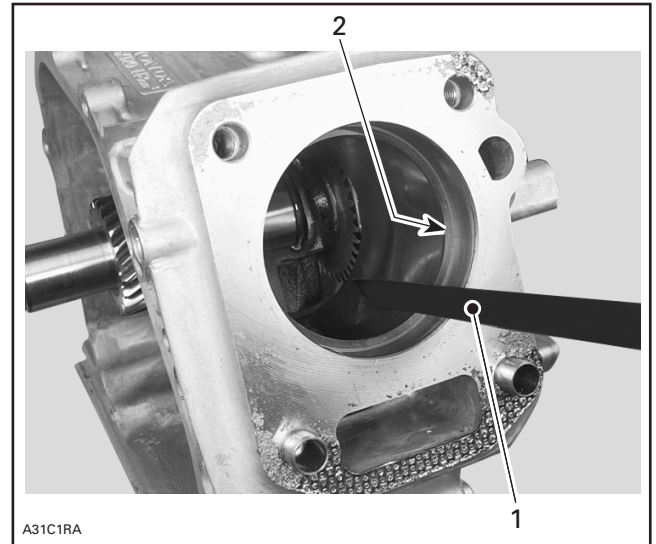

1. Feeler gauge
2. Ring properly positioned in cylinder

### CONNECTING ROD BIG END SIDE CLEARANCE

STANDARD	SERVICE LIMIT
0.1 - 0.7 mm (0.004 - 0.028 in)	1.1 mm (0.043 in)

Using a feeler gauge, measure distance between connecting rod and crankshaft counterweight. If the distance exceeds specified tolerance, replace the crankshaft.

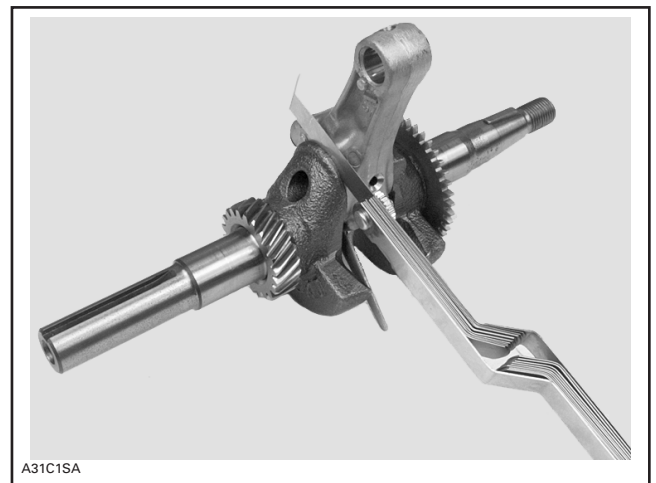

MEASURE SIDE CLEARANCE

## Section 04 ENGINE

### Subsection 05 (COMPRESSION TEST AND ENGINE DIMENSION MEASUREMENT)

#### PISTON PIN (outside diameter)

STANDARD	SERVICE LIMIT
13.0 mm (0.51 in)	12.954 mm (0.5100 in)

Measure piston pin with a micrometer, as shown in the next photo.



MEASURE PISTON PIN

#### PISTON PIN BORE (inside diameter)

STANDARD	SERVICE LIMIT
13.002 mm (0.5119 in)	13.048 mm (0.5137 in)

Measure piston pin bore with a telescoping gauge and a micrometer, as shown in the next photo.

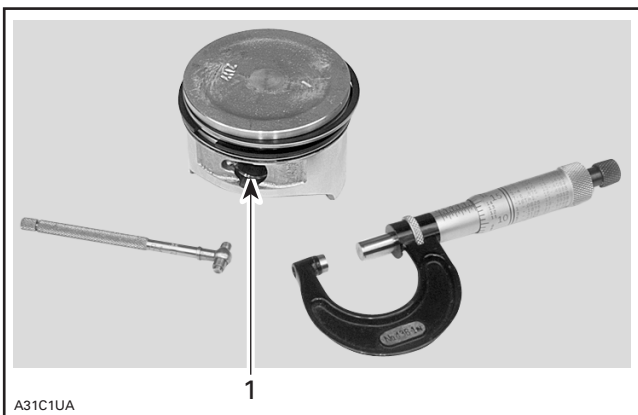

1. Piston pin bore

#### PISTON-TO-PISTON PIN BORE CLEARANCE

STANDARD	SERVICE LIMIT
0.002 - 0.014 mm (0.0001 - 0.0006 in)	0.08 mm (0.003 in)

Compare both previously measured piston pin (outside diameter) and piston pin bore (inside diameter).

If clearance is out of service limit value, replace piston pin or piston as needed.

#### CONNECTING ROD SMALL END (inside diameter)

STANDARD	SERVICE LIMIT
13.005 mm (0.5120 in)	13.07 mm (0.515 in)

Measure connecting rod small end (inside diameter) with a telescoping gauge and a micrometer, as shown in the next photo.



MEASURE CONNECTING ROD SMALL END

#### CONNECTING ROD BIG END (inside diameter)

STANDARD	SERVICE LIMIT
26.02 mm (1.024 in)	26.066 mm (1.0262 in)

Measure connecting rod big end (inside diameter) with a telescoping gauge and a micrometer, as shown in the next photo.



MEASURE CONNECTING ROD BIG END

### CONNECTING ROD BIG END OIL CLEARANCE

STANDARD	SERVICE LIMIT
0.040 - 0.063 mm (0.0016 - 0.0025 in)	0.12 mm (0.005 in)

Clean all oil from crankpin and connecting rod big end surfaces.

Position a piece of plastigauge on the crankpin, as shown on the next photo.



1. Plastigauge properly positioned

Reinstall connecting rod cap and torque screws to 12 N•m (109 lbf•in). See next photo.

**NOTE:** Do not rotate crankshaft while plastigauge is in place.

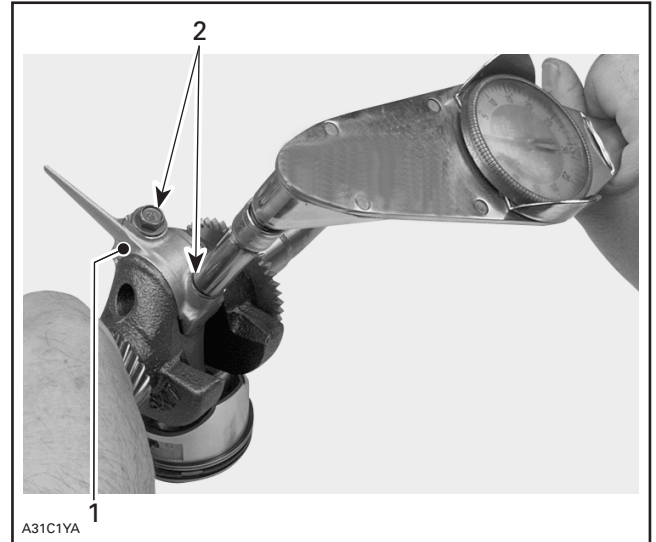

1. Connecting rod cap in place  
2. Torque both screws

Remove connecting rod cap and measure the plastigauge, as shown in the next photo.

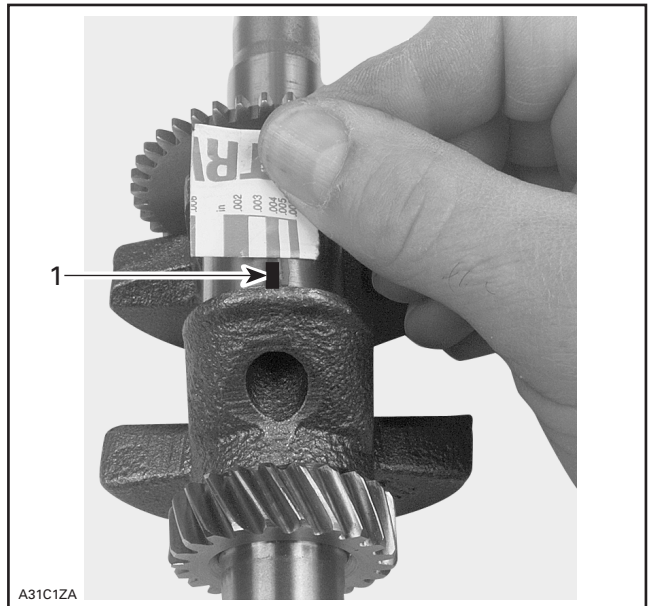

1. Plastigauge

If clearance exceeds the service limit, replace connecting rod and recheck clearance.

**NOTE:** Replacement connecting rods are available with standard and 0.25 mm (0.010 in) under-size bearing surfaces.

## Section 04 ENGINE

### Subsection 05 (COMPRESSION TEST AND ENGINE DIMENSION MEASUREMENT)

#### CRANKPIN (outside diameter)

STANDARD	SERVICE LIMIT
25.98 mm (1.023 in)	25.92 mm (1.020 in)

Measure crankpin outside diameter with a micrometer, as shown in the next photo.



MEASURE CRANKPIN

#### CAMSHAFT CAM HEIGHT

	STANDARD	SERVICE LIMIT
INTAKE	27.7 mm (1.09 in)	27.45 mm (1.081 in)
EXHAUST	27.75 mm (1.093 in)	27.50 mm (1.083 in)

Measure both camshaft cams with a micrometer, as shown in the next photo.

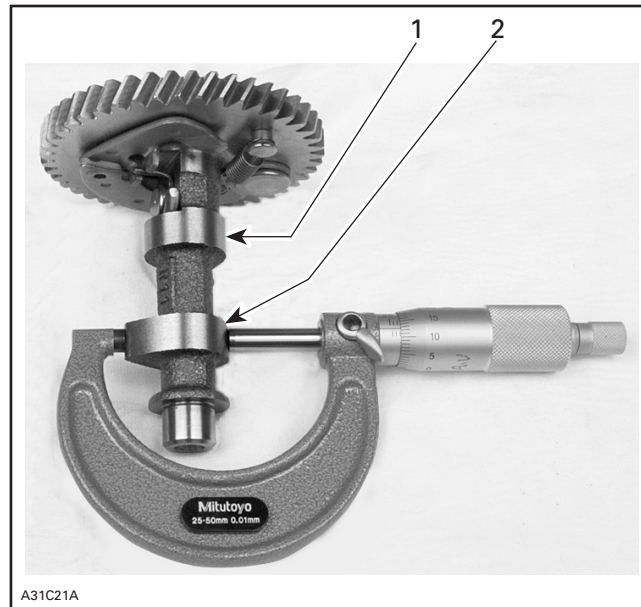

1. Exhaust valve cam
2. Intake valve cam

#### CAMSHAFT (outside diameter)

STANDARD	SERVICE LIMIT
13.984 mm (0.5506 in)	13.916 mm (0.5479 in)

Measure camshaft outside diameter with a micrometer, as shown in the following photo.



MEASURE CAMSHAFT OUTSIDE DIAMETER

## CAMSHAFT HOLDER (inside diameter)

STANDARD	SERVICE LIMIT
14.0 mm (0.55 in)	14.048 mm (0.5531 in)

Measure camshaft holder inside diameter with a telescoping gauge and a micrometer, as shown in the next photo.

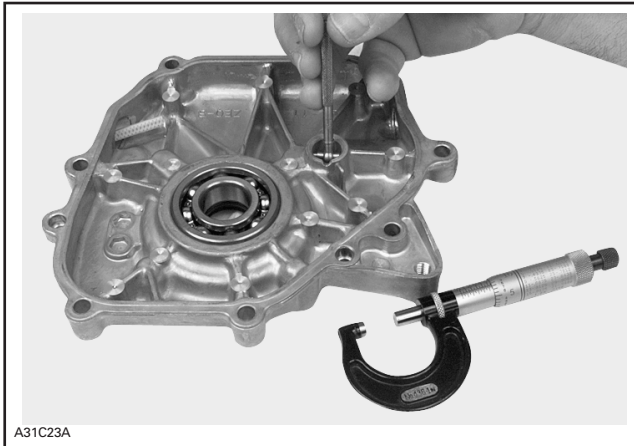

MEASURE CAMSHAFT HOLDER INSIDE DIAMETER

## CHECKING SURFACE FLATNESS

Crankcase cover can be checked for perfectly mating surfaces.

Lay part on a surface plate (marble, mirror or thick glass plate).

Holding down one end of part, try pushing down the other end.

If any play is felt, part must be rectified.

## RECTIFYING SURFACES

Stick a fine sand paper sheet on the surface plate then lightly oil the sand paper.

Rub manifold mating surface on sand paper using 8-figure movements.

Sand until mating surface is perfectly straight.

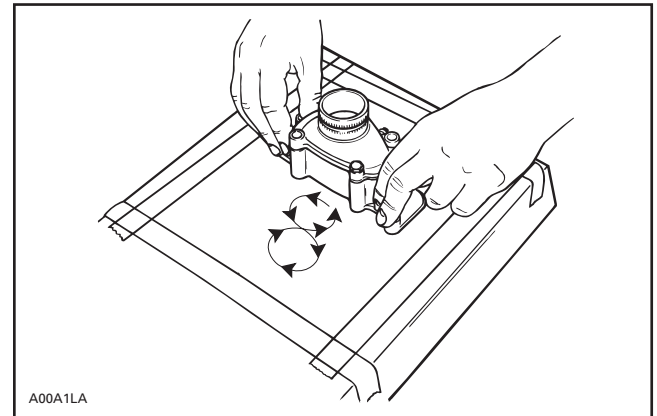



# TRANSISTORIZED MAGNETO IGNITION

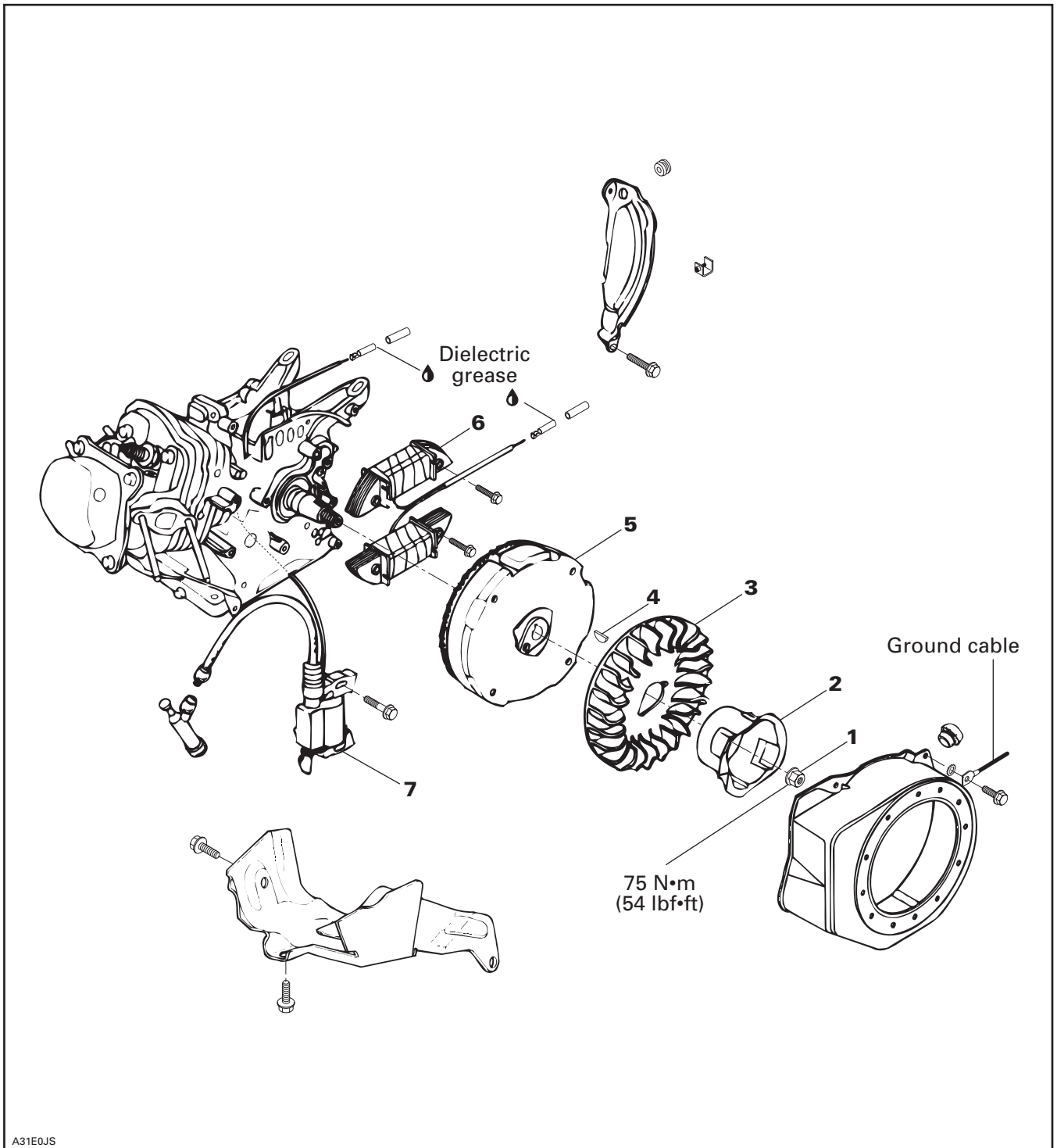

## Section 04 ENGINE

### Subsection 06 (TRANSISTORIZED MAGNETO IGNITION)

**NOTE:** Engine must be removed to perform the following procedures.

## CLEANING

Clean all metal components in a non-ferrous metal cleaner.

### ▼ CAUTION

Clean armature and magneto using only with a clean cloth.

## DISASSEMBLY

To gain access to magneto assembly, remove the following parts:

- chain guard
- drive chain
- clutch
- muffler
- disconnect fuel line
- engine
- rewind starter

Remove ignition coil **no. 7**.

To remove magneto flywheel retaining nut **no. 1**, use clutch holder tool (P/N 529 006 400), as shown in the next photo.

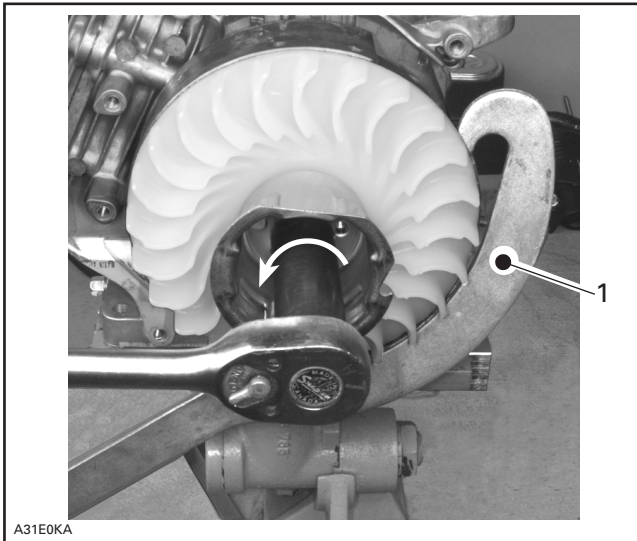

### LOOSEN FLYWHEEL NUT

1. Hold flywheel using clutch holder tool (P/N 529 006 400)

Remove starter pulley **no. 2** and fan **no. 3**.

Reinstall magneto flywheel nut then using puller, detach flywheel **no. 5**, as shown in the next photo.

### ▼ CAUTION

Never hold flywheel using magnet section. Flywheel may be damaged.

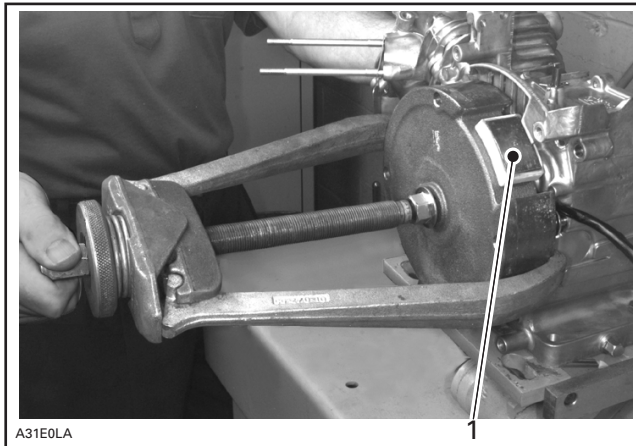

1. Magnet section

**NOTE:** Tighten puller bolt and at same time, tap on bolt head using a hammer to release magneto flywheel from its taper.

## INSPECTION

Test ignition **no. 7** and lamp **no. 6** coils as described in TESTING PROCEDURE 06-03.

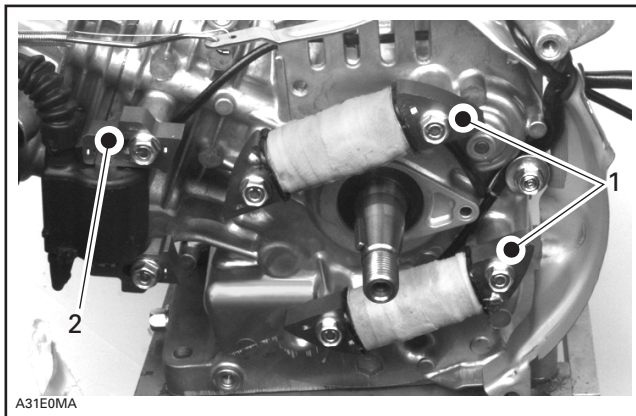

1. Lamp coils
2. Ignition coil

## ASSEMBLY

Clean crankshaft extension (taper).

Position Woodruff key no. 4 then reinstall flywheel with fan.

Install starter pulley, as shown in the next photo.

### ▼ CAUTION

When installing starter pulley, ensure that locating pin is properly aligned with flywheel alignment hole.

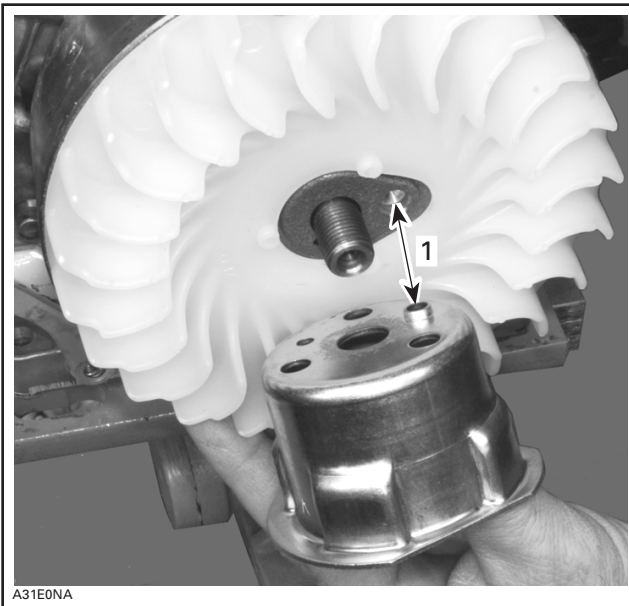

1. Starter pulley locating pin must be aligned with flywheel hole

Torque flywheel nut to 75 N•m (54 lbf•ft).

At reassembly coat all electric connections with silicone dielectric grease (P/N 413 701 700) to prevent corrosion or moisture penetration.

### ▼ CAUTION

Do not use silicone "sealant", this product will corrode contacts.

## Ignition Coil Air Gap Adjustment

**NOTE:** To perform ignition coil air gap adjustment, flywheel must be tightened.

Loosen ignition coil screws.

Insert filler gauge between flywheel and ignition coil. Adjust both gaps at the same time as shown in the next photo and according to the following table.

Specified clearance	0.4 ± 0.2 mm (0.016 ± 0.008 in)
---------------------	------------------------------------

Push the ignition coil firmly toward flywheel and tighten screws.

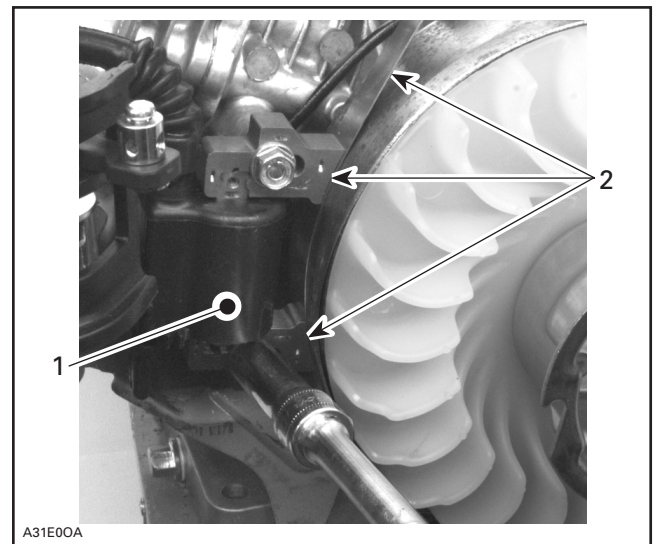

1. Ignition coil  
2. Filler gauge filling both gaps

### ▼ CAUTION

Do not adjust ignition coil air gap at magnet section on flywheel.

# REWIND STARTER

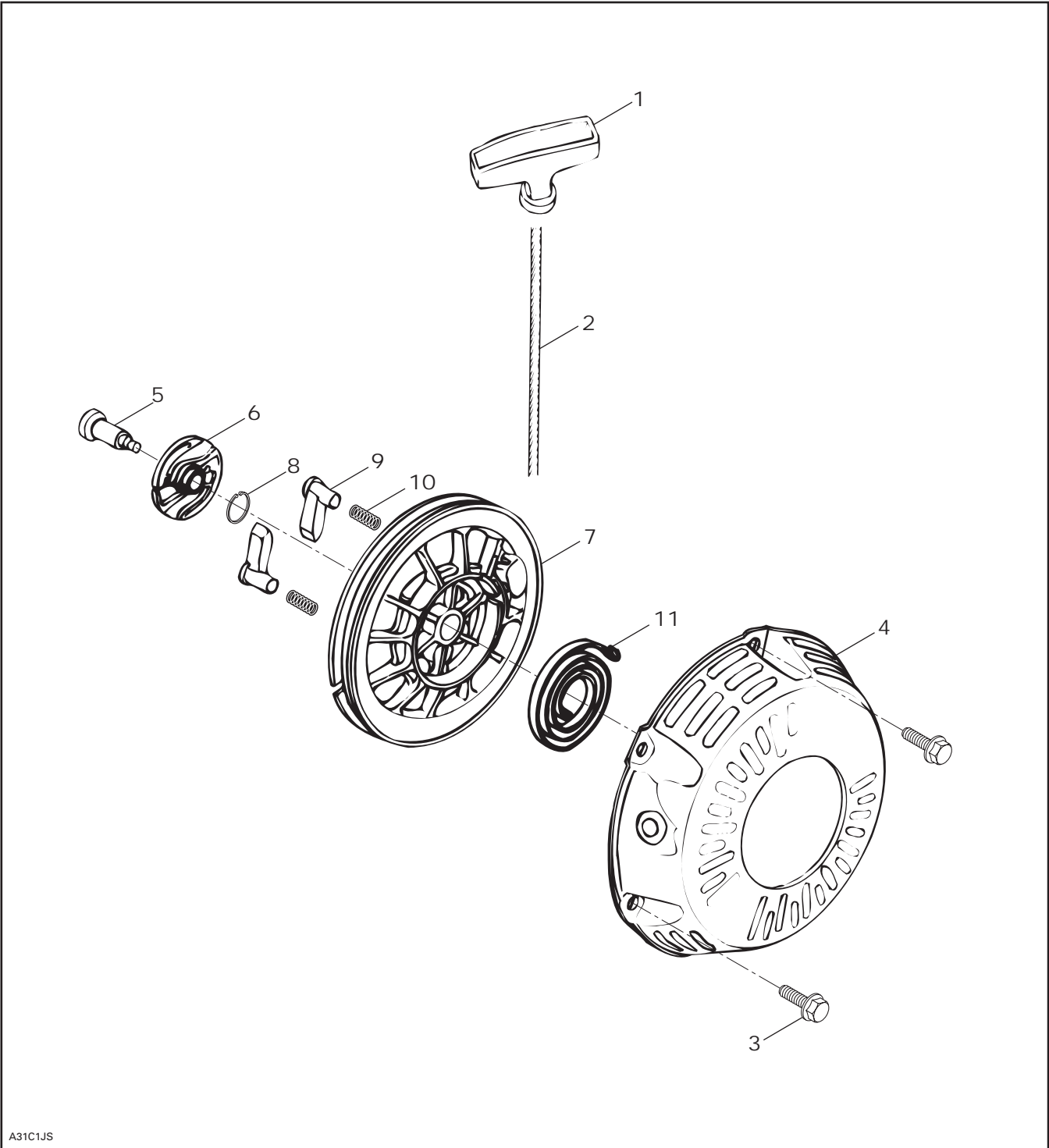

A31C1JS

## Section 04 ENGINE

### Subsection 07 (REWIND STARTER)

#### REMOVAL

The following must be removed before rewind starter removal:

- chain guard
- drive chain
- clutch
- disconnect fuel hose
- engine

Using a small screwdriver, extract rope knot from starter grip **no. 1**. Cut rope **no. 2** close to knot. Tie a knot near starter.

Mark rewind starter housing **no. 4** position for re-assembly.

Remove screws **no. 3** securing rewind starter housing **no. 4** to engine then remove rewind starter ass'y.

#### DISASSEMBLY

To remove rope from rewind starter mechanism:

Place rewind starter ass'y on a bench.

- First remove screw **no. 5**, then ratchet guide **no. 6**.
- Remove friction spring **no. 8** and both ratchets **no. 9** with springs **no. 10**.
- Remove sheave **no. 7** from starter housing, as shown in the next illustration.

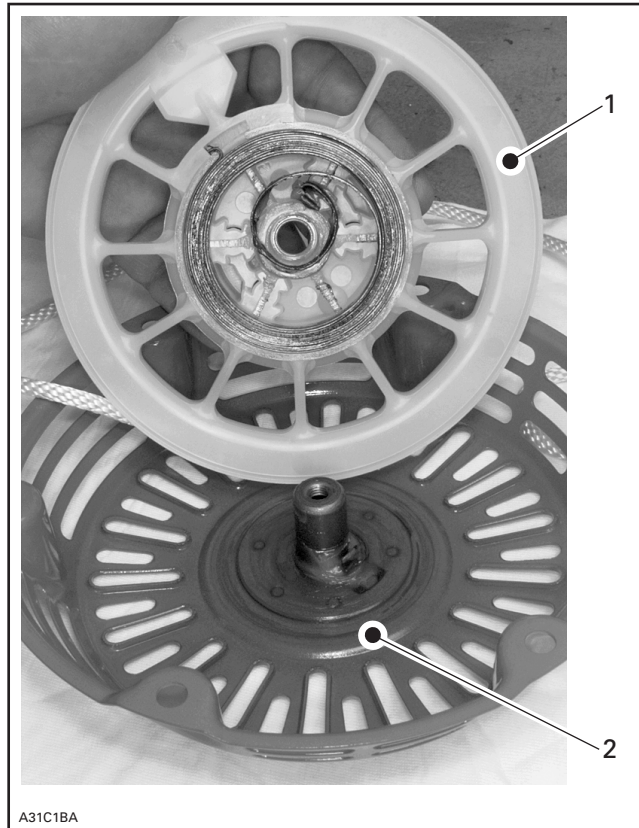

1. Sheave
2. Rewind starter housing

#### ◆ WARNING

Since the spring is tightly wound inside the guide it may fly out when rewind is handled. Always handle with care.

## INSPECTION

Check rope no. 2 for fraying. Replace if so.

## ASSEMBLY

At assembly, position spring no. 11 outer end into spring guide notch then wind the spring counter-clockwise into guide.

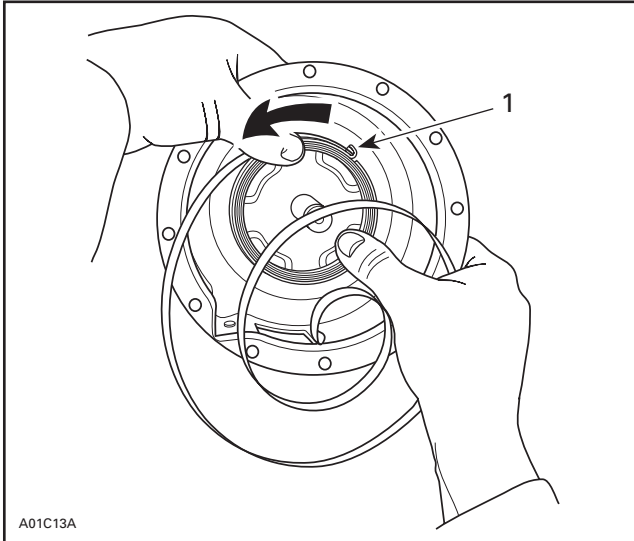

### TYPICAL

1. Outer end into guide notch

**NOTE:** Due to dust accumulation, rewind starter must be periodically cleaned, inspected and relubricated.

## ▼ CAUTION

It is of the utmost importance that the rewind starter spring be lubricated periodically using specific lubricants. Otherwise, rewind starter component life will be shortened and/or rewind starter will not operate properly under very cold temperatures.

Lubricate spring assembly with silicone compound grease (P/N 420 897 061) and position into starter housing as in the next photo.

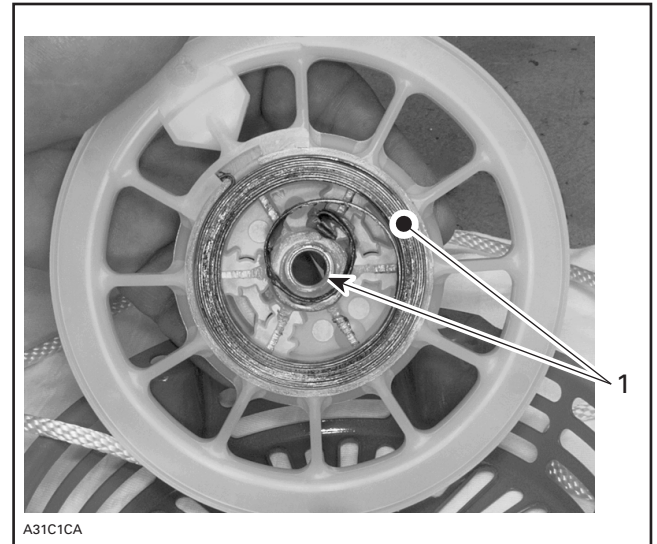

1. Grease inside spring guide and sheave hub

## ▼ CAUTION

The use of standard multi-purpose grease could result in rewind starter malfunction.

To install a new rope:

Insert rope into sheave orifice and lock it with a knot as illustrated.

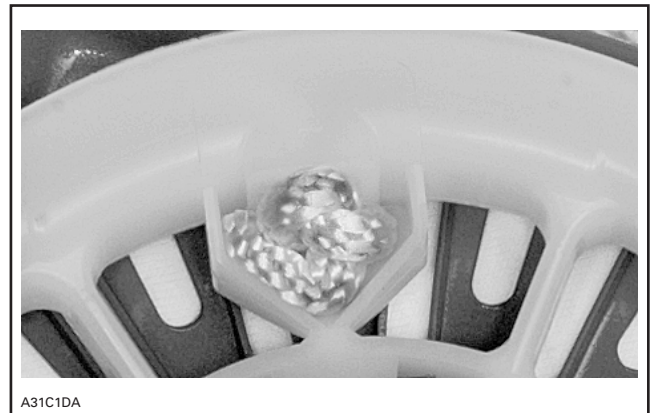

ROPE KNOT INTO SHEAVE ORIFICE

## Section 04 ENGINE

### Subsection 07 (REWIND STARTER)

To adjust rope tension:

Wind rope on sheave and place sheave into starter housing making sure that the sheave hub notch engages in the rewind spring hook. See the next photo.

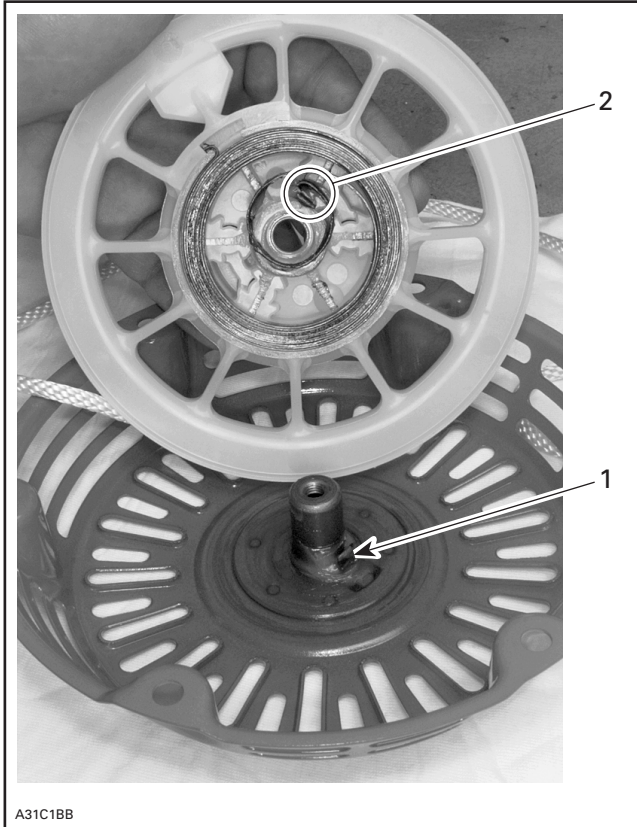

1. Sheave hub notch
2. Rewind spring hook

Rotate the sheave counterclockwise until rope end is accessible through starter housing orifice.

Pull the rope out of the starter housing and temporarily make a knot to hold it.

Position both ratchets (with springs), as shown in the next photo.

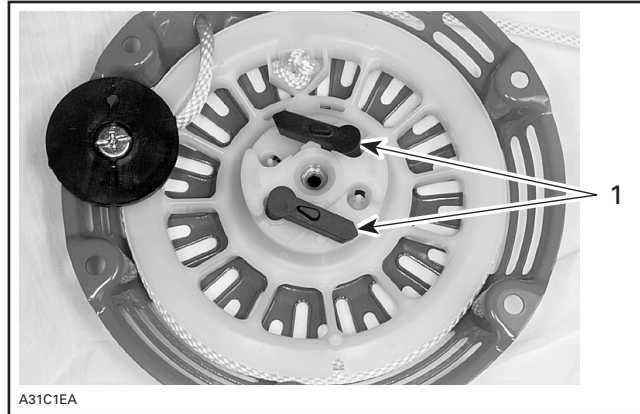

1. Ratchet

Finalize rewind starter assembly with friction spring no. 8, ratchet guide no. 6 and screw no. 5.

Attach rope to sheave notch then turn (2 turns) sheave counterclockwise, as shown in the next photo. One turn preload will give 7 turns of tension when fully extended.



**2 TURNS COUNTERCLOCKWISE**

1. Sheave notch

Check ratchet operation: when turning ratchet guide counterclockwise, ratchets must move in. When turning ratchet guide clockwise, ratchets must move out as shown in the next photo.

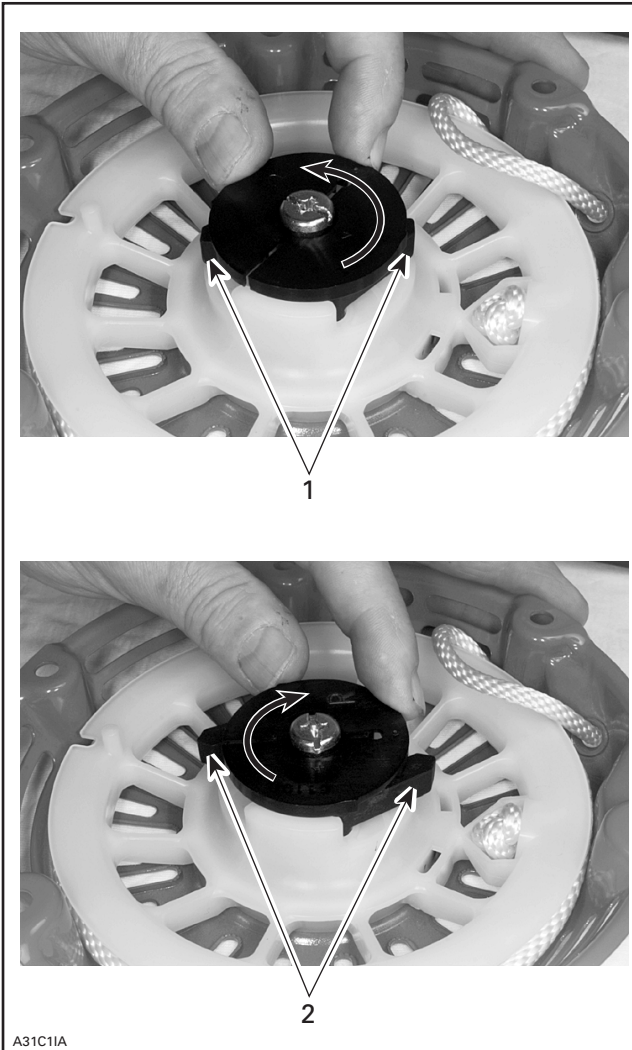

1. Turn counterclockwise (CCW) — ratchets in
2. Turn clockwise (CW) — ratchets out

## INSTALLATION

Reinstall rewind starter ass'y on engine.

Reinstall engine in snowmobile.

Prior to installing starter grip **no. 1** on new rope, it is first necessary to fuse the rope end with a lit match.

Pass rope through snowmobile fitting and starter grip and tie a knot in the rope end. Fuse the knot with a lit match then insert rope end down and pull the starter grip over the knot.

Reconnect fuel hose.

Reinstall clutch, drive chain, then chain guard.



# CARBURETOR

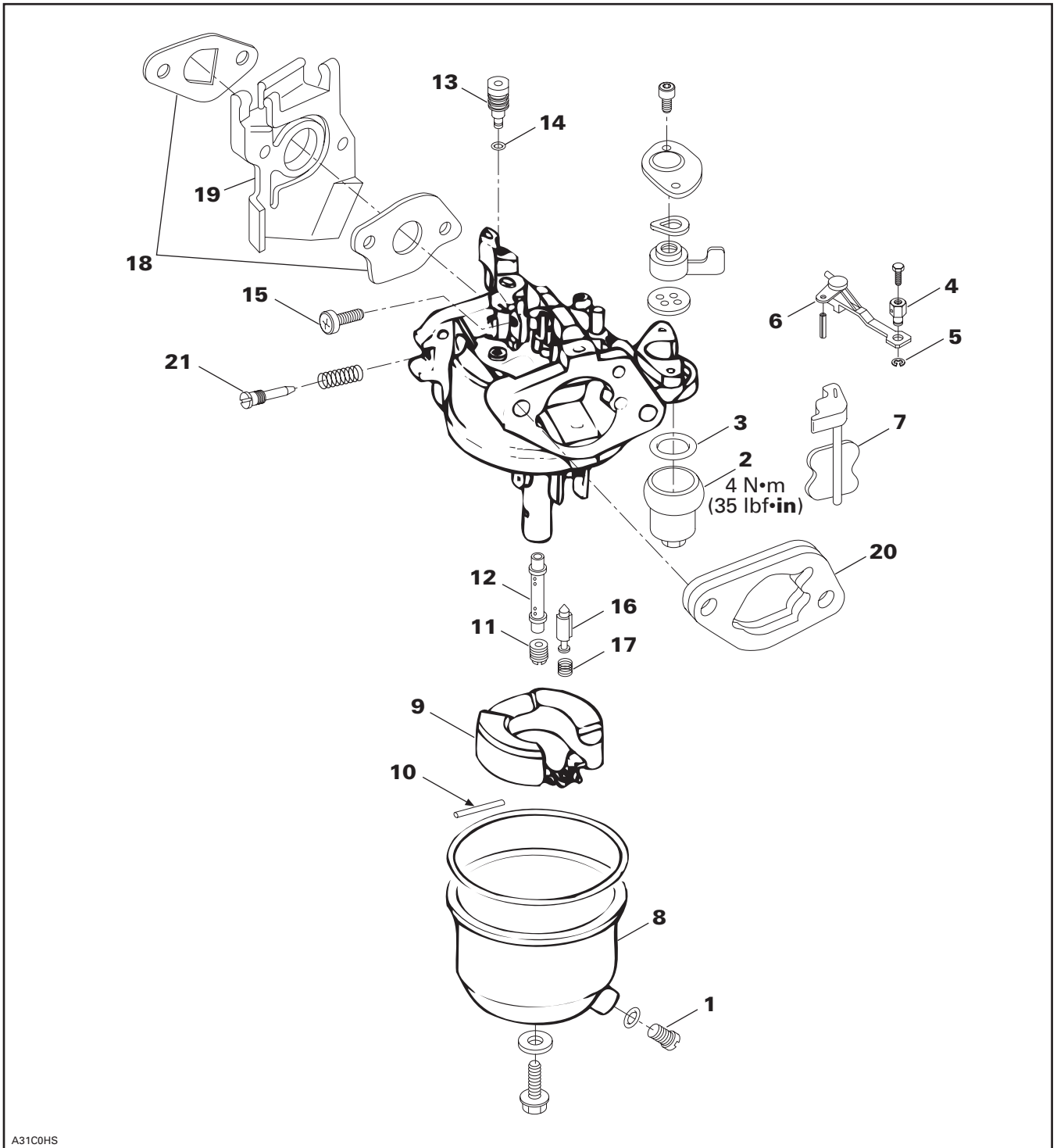

A31C0HS

Section 04 ENGINE  
Subsection 08 (CARBURETOR)

## REMOVAL

Remove engine protective plate.

Obstruct fuel line with a hose pincher (P/N 295 000 076), as shown in the next photo.

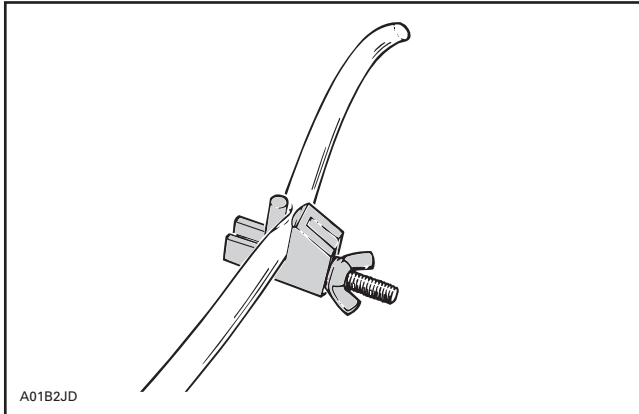

Drain fuel from carburetor by loosening screw **no. 1**, as shown in the next photo.

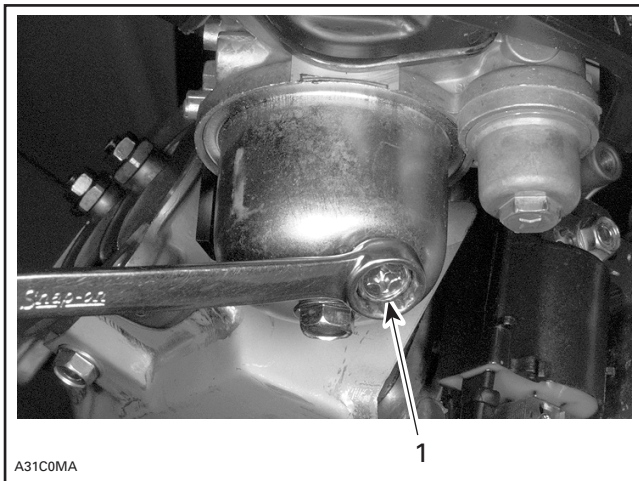

### TO DRAIN CARBURETOR

1. Loosen this screw

Loosen fuel strainer cup **no. 2** and remove from carburetor. Keep O-ring **no. 3**, as shown in the next photo.

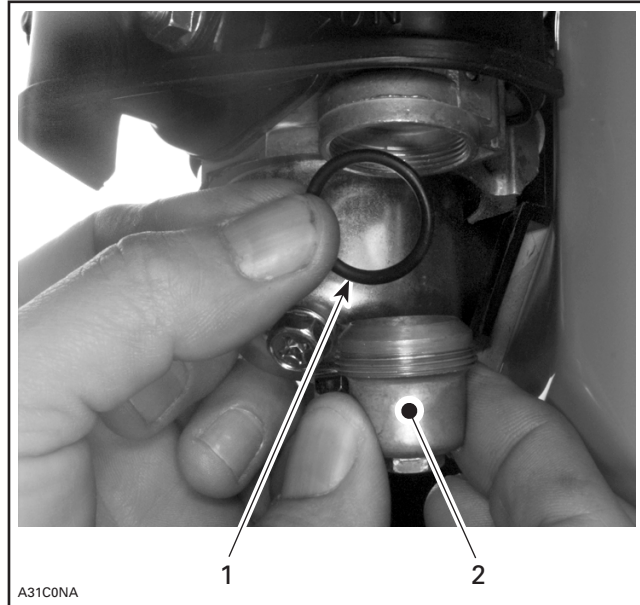

### REMOVE FUEL STRAINER CUP

1. O-ring
2. Fuel strainer cup

Disconnect fuel inlet line from carburetor and drain fuel from tank.

## ◆ WARNING

When draining a fuel tank or whenever a fuel line is disconnected, obstruct line with a hose pincher (P/N 295 000 076) or equivalent device. Fuel is flammable and explosive under certain conditions. Ensure work area is well ventilated. Do not smoke or allow open flames or sparks in the vicinity.

Remove fuel tank.

Remove carburetor cap.

Detach choke cable from choke cable attachment **no. 4**, located on carburetor choke lever **no. 6**.

**Section 04 ENGINE**  
**Subsection 08 (CARBURETOR)**

Remove circlip no. 5 then remove choke cable attachment from carburetor choke lever, as shown in the next photo.

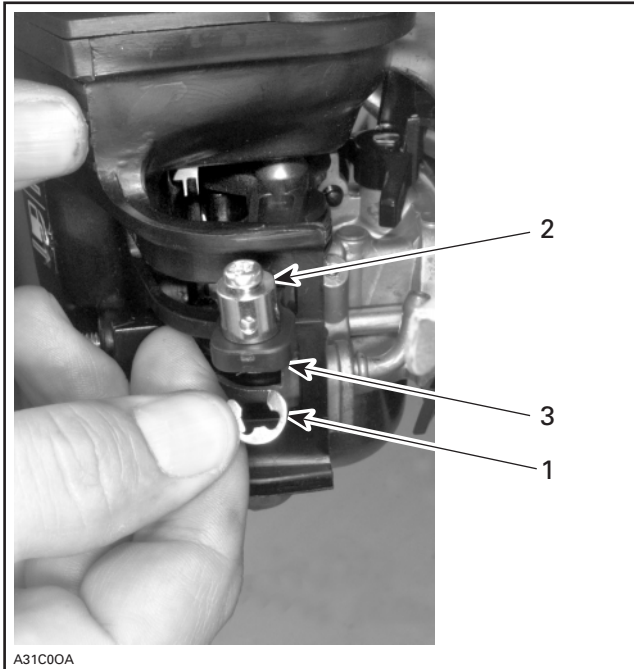

1. Circlip
2. Choke cable attachment
3. Carburetor choke lever

Move carburetor choke lever to the left, as shown in the next photo.

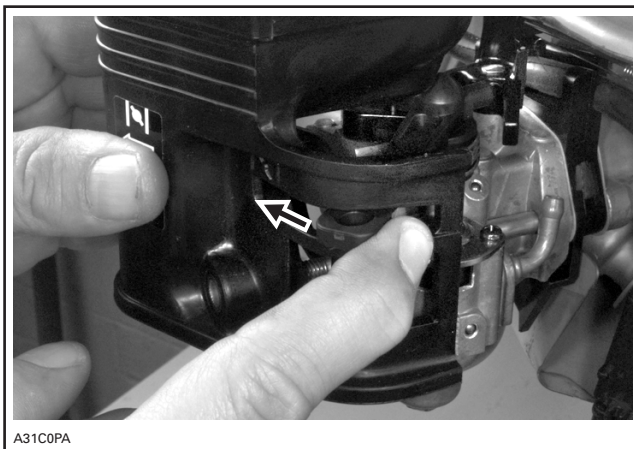

**MOVE CARBURETOR CHOKE LEVER**

Unscrew carburetor protector screws then remove carburetor nuts.

Remove carburetor protector, as shown in the next photo.

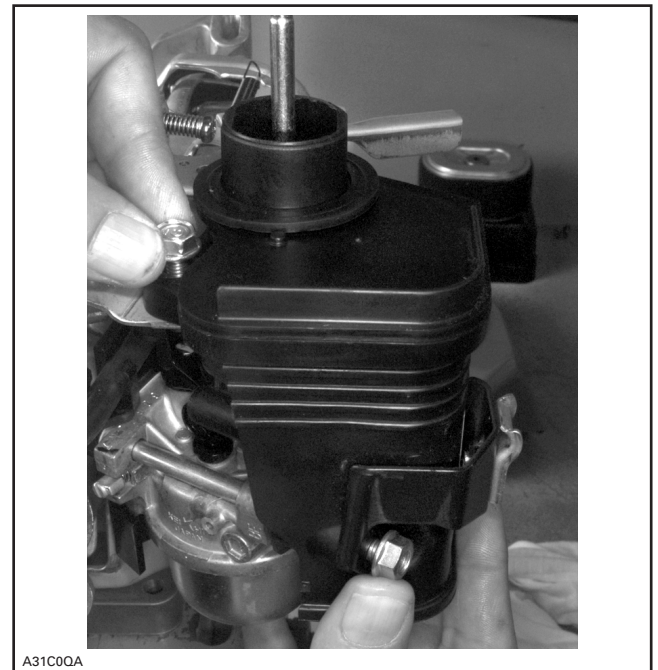

**REMOVE CARBURETOR PROTECTOR**

Lift up choke lever no. 6 and detach from choke no. 7, as shown in the next photo.

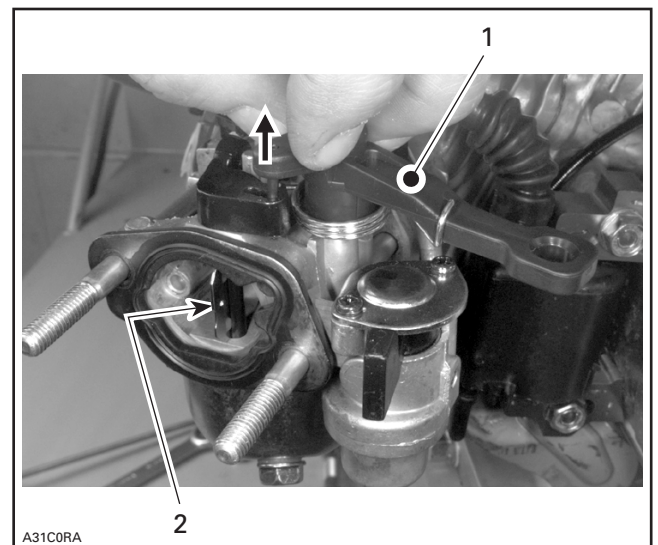

**LIFT UP CHOKE LEVER**

1. Choke lever
2. Choke

## Section 04 ENGINE

### Subsection 08 (CARBURETOR)

Slide out carburetor and activate carburetor throttle lever so that groove align with governor rod, as shown in the next photo.

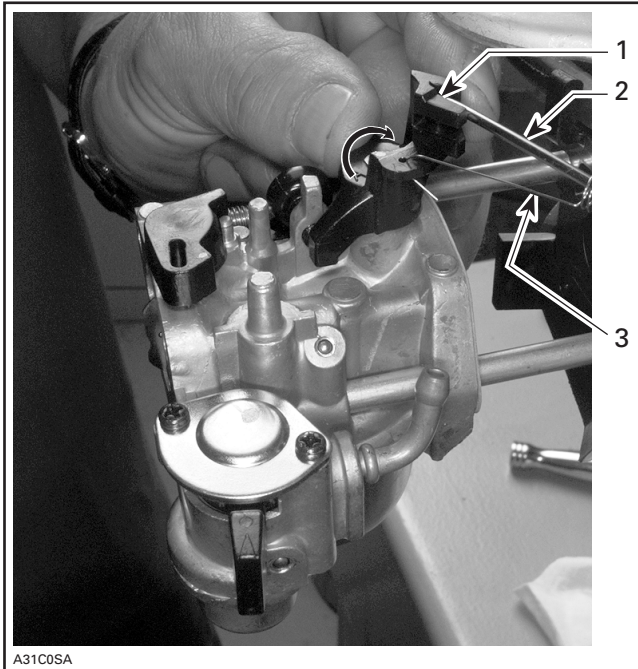

A31C0SA

#### SLIDE OUT CARBURETOR AND ALIGN GROOVE

1. Carburetor throttle lever groove aligned with governor rod
2. Governor rod
3. Throttle return spring

Detach governor rod with throttle return spring.

Detach governor spring.

Remove carburetor.

**NOTE:** Carburetor can be removed without removing engine from vehicle, in that case remove left side stud.

## CLEANING AND INSPECTION

The entire carburetor should be cleaned with a general solvent and dried with compressed air before disassembly.

### ▼ CAUTION

Heavy duty carburetor cleaner may be harmful to the float material and to the rubber parts, O-rings, etc. Therefore, it is recommended to remove those parts prior to cleaning.

Carburetor body and jets should be cleaned in a carburetor cleaner following manufacturer's instructions.

### ◆ WARNING

Solvent with a low flash point such as gasoline, naphtha, benzol, etc., should not be used as they are flammable and explosive.

Check for fuel soaked into float **no. 8**. Replace as necessary.

Check float **no. 9** and float pin **no. 10** for cracks or other damages affecting free movement. Replace as necessary.

## DISASSEMBLY AND ASSEMBLY

### 11,12, Main Jet and Nozzle

Place carburetor on a clean surface, then unscrew main jet **no. 11** using a flat screwdriver, as shown in the next photo.

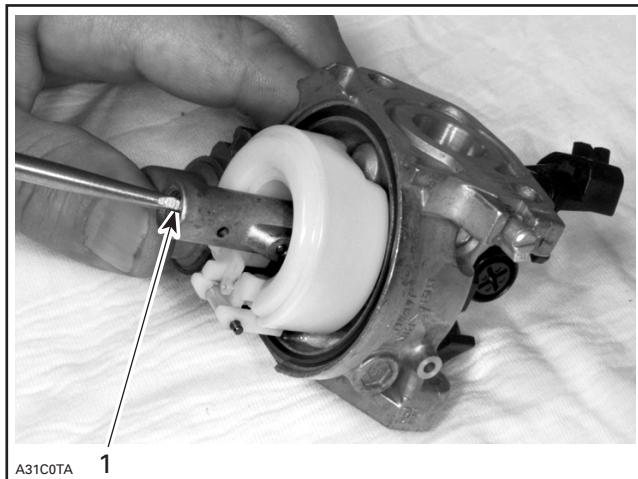

A31C0TA

1. Unscrew main jet using a flat screwdriver

To remove nozzle no. 12 use a flat screwdriver and push from inside carburetor, as shown in the following photo.

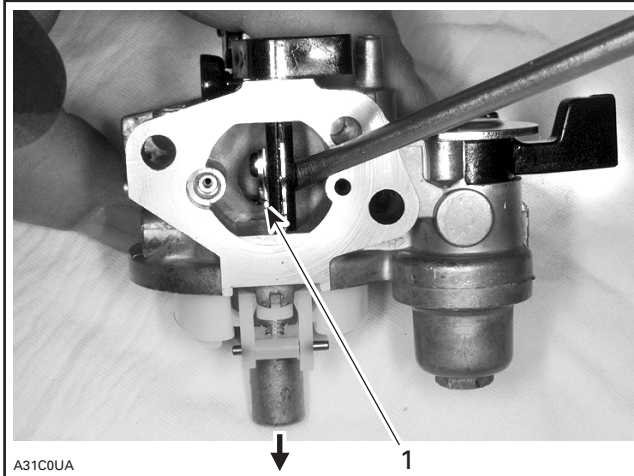

1. Push on nozzle to remove it

Clean main jet and nozzle thoroughly with compressed air.

Reinstall nozzle and main jet as shown in the next photo.

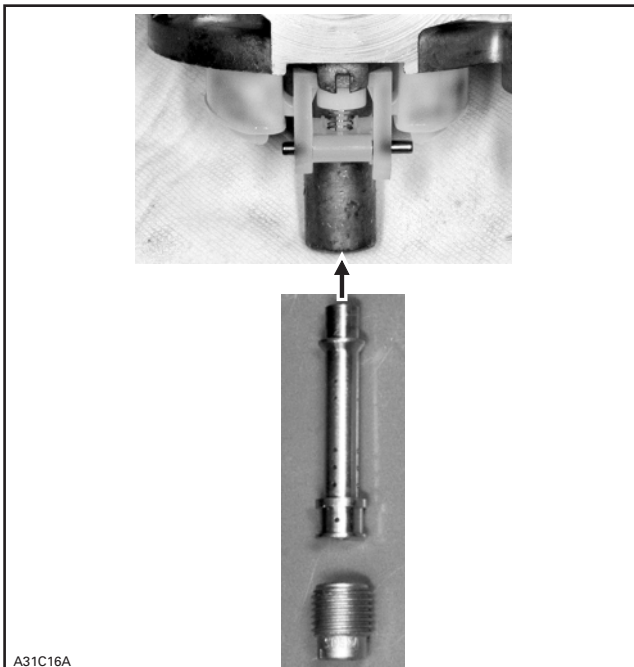

PROPER POSITION TO INSTALL NOZZLE AND MAIN JET

### 13,14, Pilot Jet

Remove stop screw no. 15.

Using a flat screwdriver remove pilot jet no. 13, as shown in the next photo.

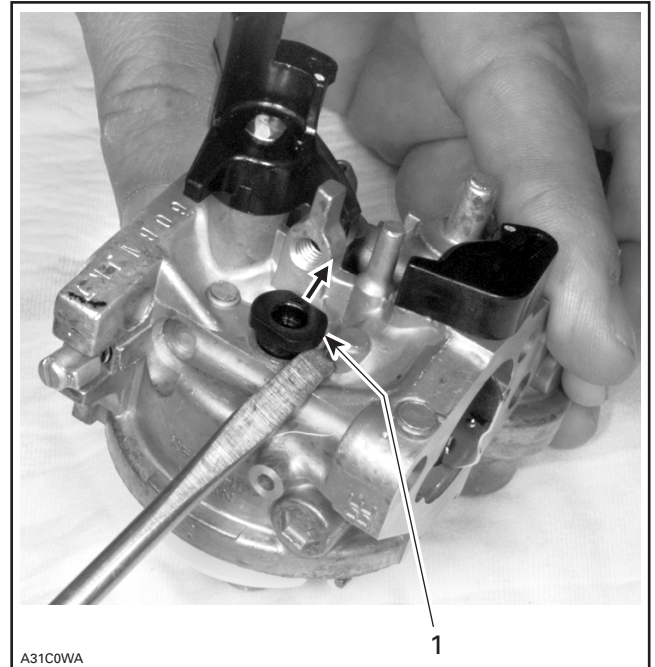

TO REMOVE, LIFT PILOT JET

1. Pilot jet

Clean pilot jet using compressed air.

Ensure that O-ring no. 14 is not damaged. If so, replace with new one. See next photo.

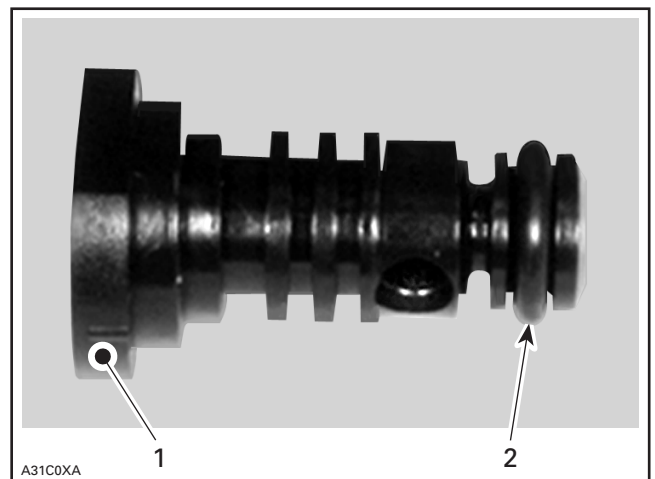

1. Pilot jet  
2. O-ring

### 16,17, Float Valve

Remove float pin no. 10 then remove float no. 9 from carburetor.

Check for worn valve seat on float. Replace if so.

Check for weak float valve spring no. 17 or worn float valve, as shown in the next photo.

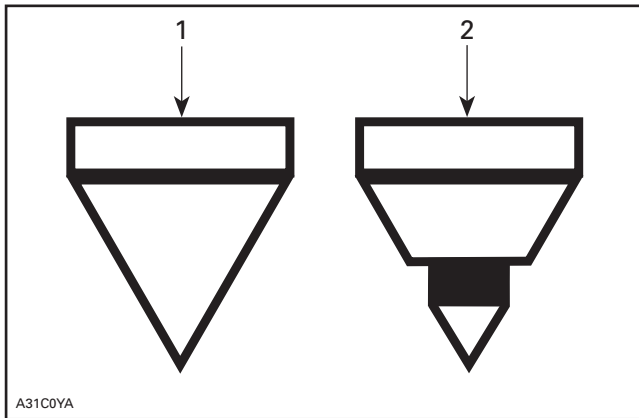

1. Float valve tip OK
2. Replace float valve

### CARBURETOR FLOAT LEVEL

Correct fuel level in float chamber is vital toward maximum engine efficiency. To check for correct float level proceed as follows:

- Remove float bowl no. 8 and gasket from carburetor.
- With carburetor leaned on a clean surface, measure float level height H using float level gauge (P/N 529 035 520), as shown in the next photo.
- Keep float level gauge perfectly vertical and in line with main jet hole.
- Ensure that both float level gauge tips are properly positioned on carburetor body and that “L” arm is leaning on float without compressing valve spring.

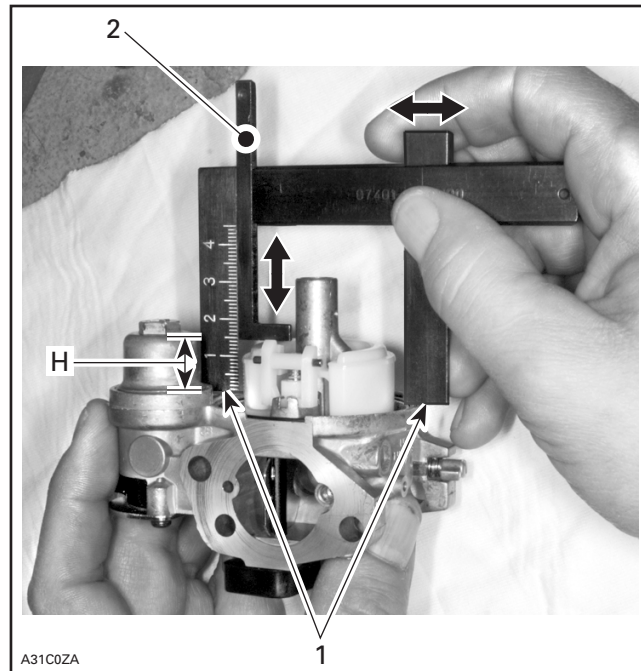

1. Float level gauge tips properly leaned on carburetor body
  2. Lean “L” arm to carburetor to measure float level height
- H. Float level height

STANDARD FLOAT HEIGHT	13.7 mm (0.54 in)
-----------------------	-------------------

If float height is not according to specifications on above table, replace float and/or float valve.

Recheck float level height.

### INSTALLATION

To install carburetor on engine, inverse removal procedure.

However, pay attention to the following:

- Inspect throttle cable and housing prior to installation.

- Ensure that both packings no. 18 and insulator no. 19 are properly positioned between cylinder head and carburetor, as shown in the next photo.

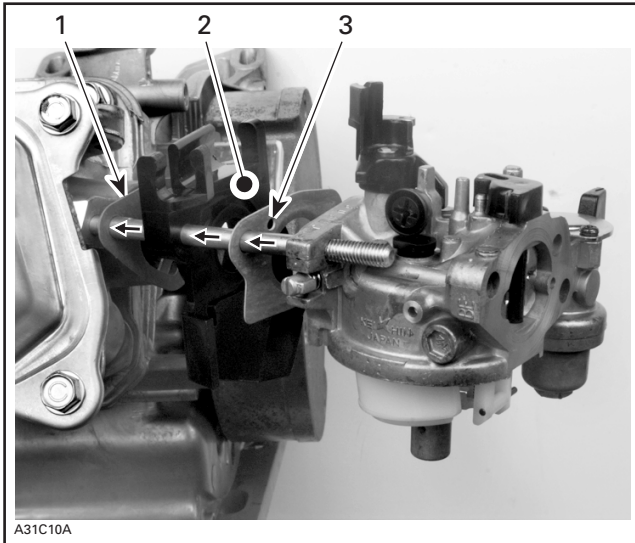

1. Packing
2. Insulator
3. Note packing hole position

- Ensure that spacer no. 20 is properly positioned between carburetor and air cleaner elbow ass'y, as shown in the following photo.

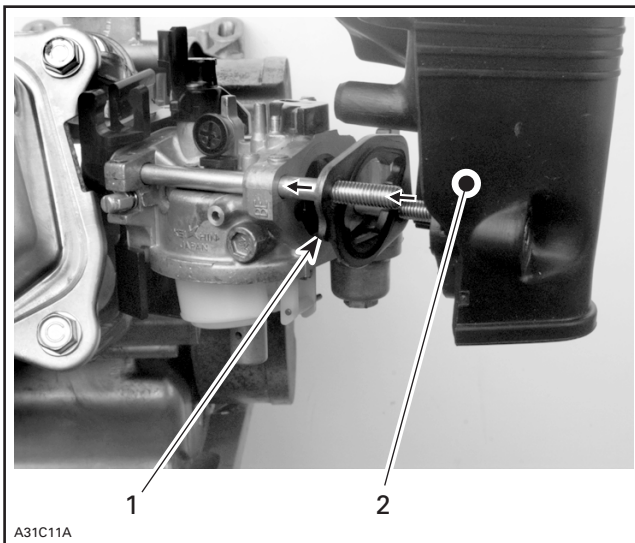

1. Spacer
2. Air cleaner elbow ass'y

## CARBURETOR ADJUSTMENTS

### Preliminary Idle Speed Adjustment

#### 21, Pilot Screw

Start engine and allow it to warm.

Adjust idle speed by turning pilot screw no. 21 clockwise or counterclockwise until highest idle RPM is attained.

### Idle Speed Final Adjustment

#### 15, Throttle Stop Screw

After the pilot screw is correctly adjusted, turn throttle stop screw no. 15 to obtain the standard idle speed.

<b>STANDARD IDLE SPEED</b>	1400 ± 200 RPM
--------------------------------	----------------

## GOVERNOR ADJUSTMENT

Loosen governor arm nut.

Turn governor arm clockwise until carburetor throttle is fully opened. Hold governor arm in this position.

Using pliers, turn governor arm shaft clockwise until it stops.

At this point tighten governor arm nut. See the next photo.

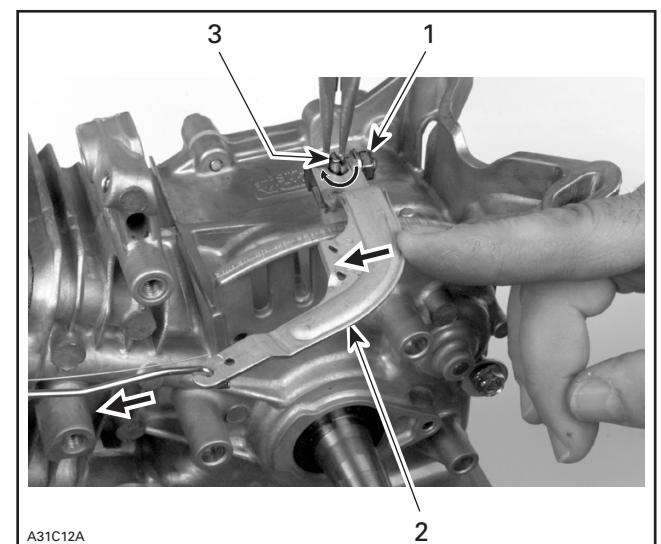

1. Governor arm nut
2. Turn governor arm to fully open throttle
3. Turn governor arm shaft

---

Section 04 ENGINE  
Subsection 08 (CARBURETOR)

---

Lift rear of snowmobile.

Start engine and allow to warm up to normal temperature.

Activate throttle lever so that engine revs to maximum standard speed.

Adjust throttle lever stop screw so that engine will not rev over maximum standard speed. Refer to TECHNICAL DATA 10-02.

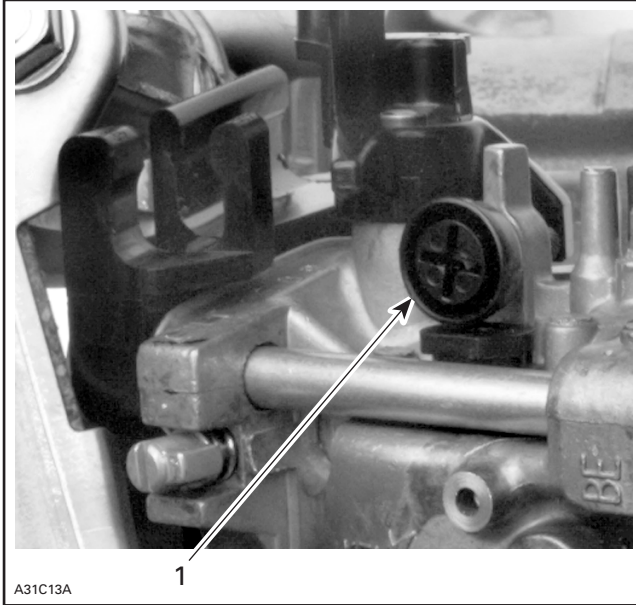

1. Adjust throttle lever stop screw



# FUEL TANK AND THROTTLE CABLE

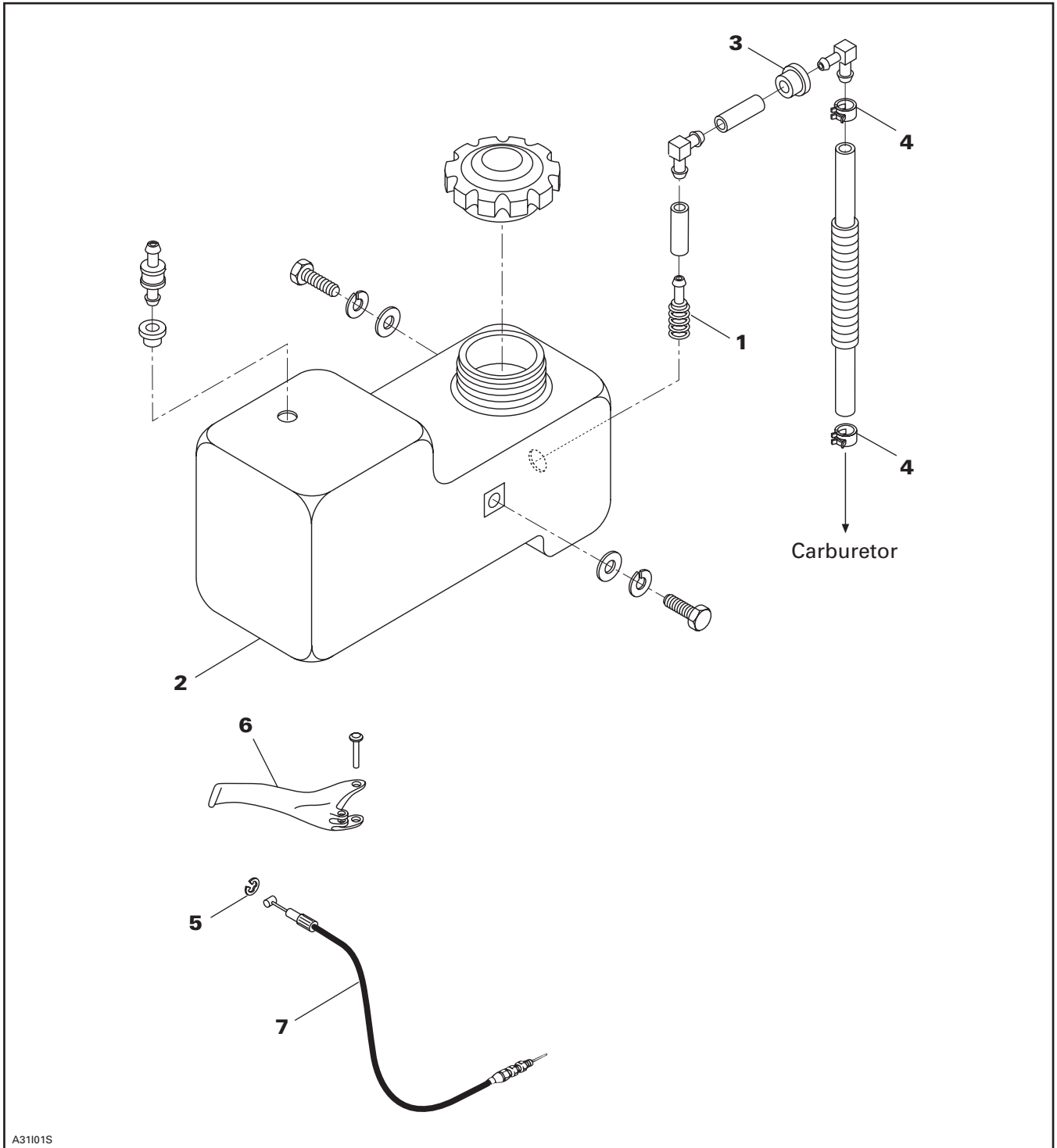

A31101S

## Fuel Tank Lines

### ◆ WARNING

When draining a fuel tank or whenever a fuel line is disconnected, obstruct line with a hose pincher (P/N 295 000 076) or equivalent device. Fuel is flammable and explosive under certain conditions. Ensure work area is well ventilated. Do not smoke or allow open flames or sparks in the vicinity.

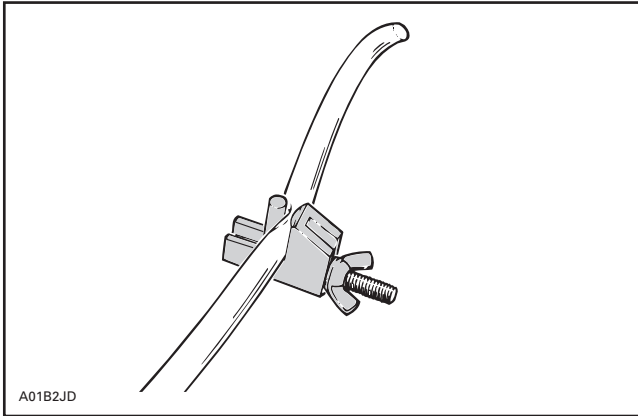

## Fuel Filter

To remove fuel filter **no. 1** from fuel tank **no. 2**, first drain fuel tank.

Using a flat screwdriver, carefully pull out fuel filter by removing grommet **no. 3**, as shown in the next photo.



REMOVE GROMMET

Ensure that fuel filter and fuel line are clean and not damaged, as per following photo.

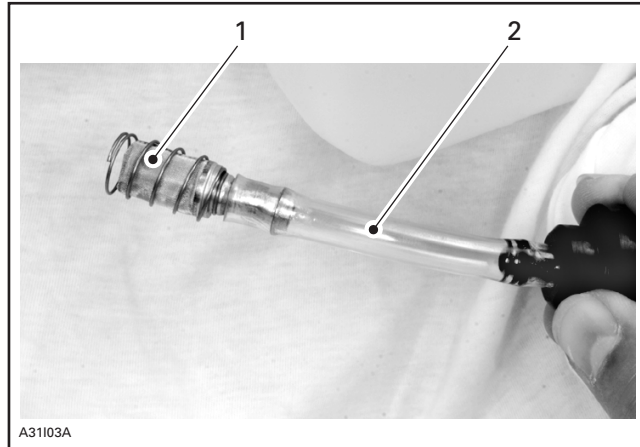

1. Fuel filter
2. Fuel line

Reinstall fuel filter with grommet.

Refuel tank and ensure there are no leaks.

## Fuel Line Spring Clips

Always reposition spring clips **no. 4** after any repair to prevent possible leaks.

## Throttle Cable Circlip at Handlebar

Put silicone grease (P/N 413 701 700) around cable barrel of throttle cable **no. 7**. Locate circlip **no. 5** as per following photo.

### ◆ WARNING

If this procedure is disregarded, throttle lever **no. 6** might be half-open at normally closed position and the engine will speed up when starting.

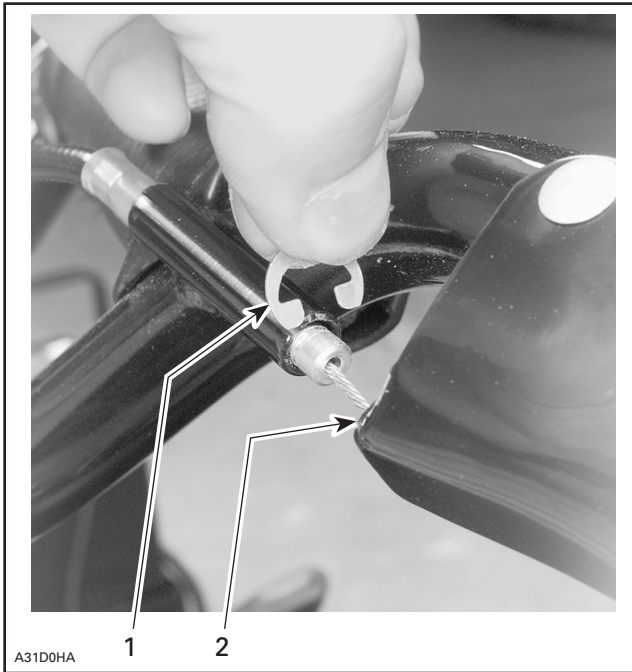

*TYPICAL — BRAKE SIDE SHOWN, IDENTICAL FOR THROTTLE SIDE*

1. Circlip
2. Detach throttle cable from throttle lever

### Throttle Cable Routing

**▼ CAUTION**

Check that throttle cable is routed away from sharp edges, hot or vibrating parts. When turning steering while engine is running, idle speed must not vary.

### Throttle Cable Adjustment

Loosen throttle cable at carburetor.

While holding handlebar throttle lever and carburetor lever at full throttle, tighten throttle cable to this position.

**◆ WARNING**

Ensure that engine is not running when adjusting throttle cable.

# TABLE OF CONTENTS

---

<b>CLUTCH</b> .....	<b>05-02-1</b>
REMOVAL .....	05-02-2
DISASSEMBLY .....	05-02-3
CLEANING .....	05-02-3
INSPECTION .....	05-02-3
INSTALLATION.....	05-02-4

---

<b>BRAKE</b> .....	<b>05-03-1</b>
REMOVAL .....	05-03-2
DISASSEMBLY .....	05-03-2
CLEANING .....	05-03-2
INSPECTION .....	05-03-3
INSTALLATION.....	05-03-3
ADJUSTMENT .....	05-03-4

---

<b>DRIVE CHAIN</b> .....	<b>05-04-1</b>
REMOVAL.....	05-04-1
INSPECTION .....	05-04-1
INSTALLATION.....	05-04-1
LUBRICATION.....	05-04-2

# CLUTCH

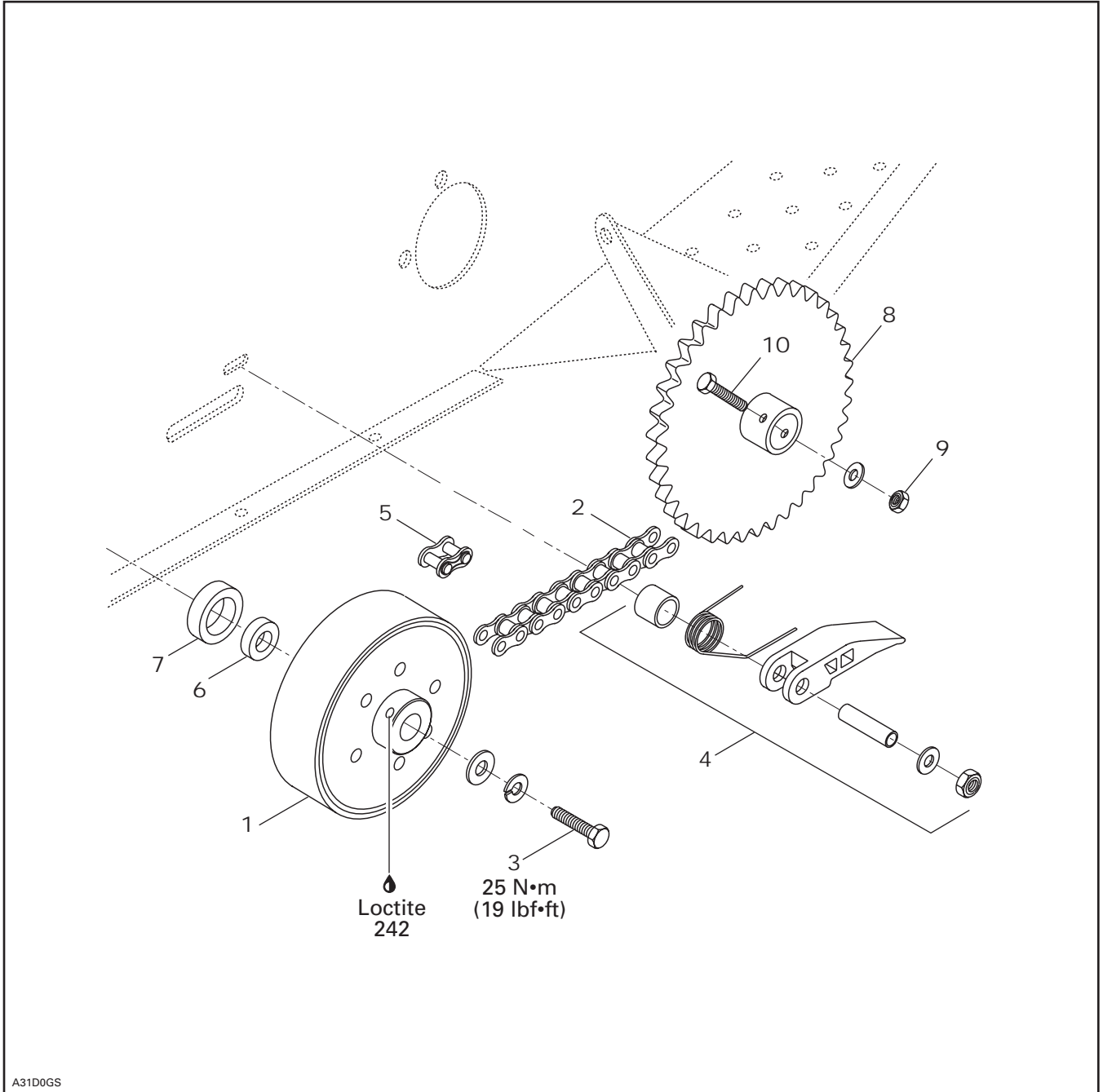

Section 05 TRANSMISSION  
Subsection 02 (CLUTCH)

**NOTE:** Parts are not available separately. If clutch no. 1 is damaged, replace clutch assembly.

## REMOVAL

**NOTE:** Clutch can be removed without removing brake. In that case drive chain no. 2 must be separated and removed first.

Lift hood.

Remove chain guard retaining screws as shown in the following photo and lift off guard.

### ◆ WARNING

When removing chain guard, ensure that engine is not running. Serious injuries may occur.

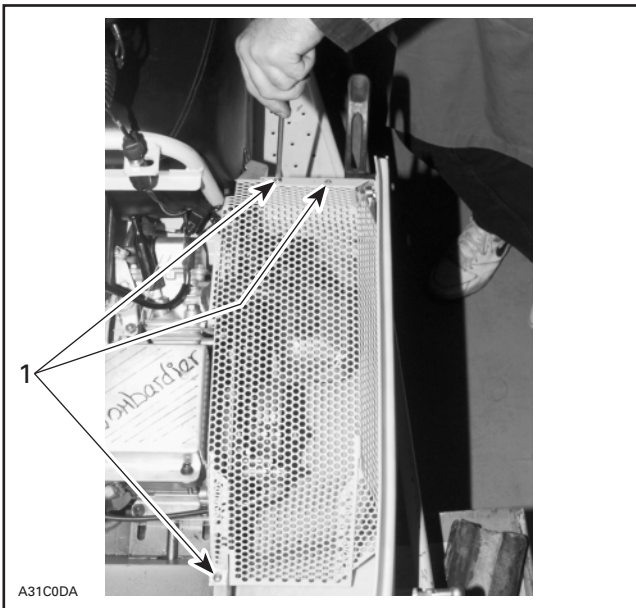

A31C0DA

1. Using a screwdriver, remove 3 screws

## Brake Pad Removal

Using Allen key, unlock brake cable from brake pad, as shown in the next photo.

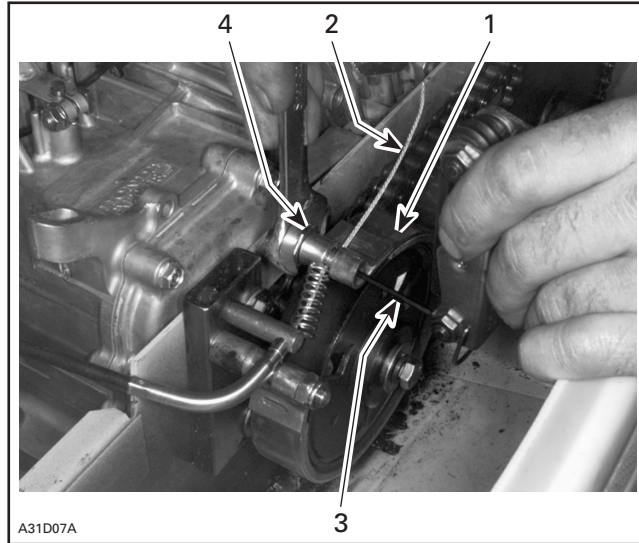

A31D07A

### UNLOCK BRAKE CABLE FROM BRAKE PAD

1. Brake pad
2. Brake cable
3. Unlock brake cable using Allen key
4. Hold screw head

Pull out brake cable from brake pad.

Remove elastic nut from pivot screw, then pull out brake pad.

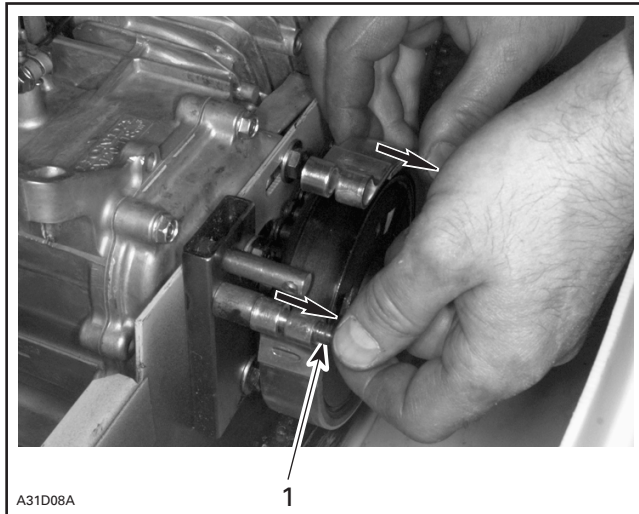

A31D08A

### REMOVE BRAKE PAD

1. Pivot screw

## 1, Clutch Removal

Holding clutch with a wrench, loosen clutch retaining screw **no. 3**.

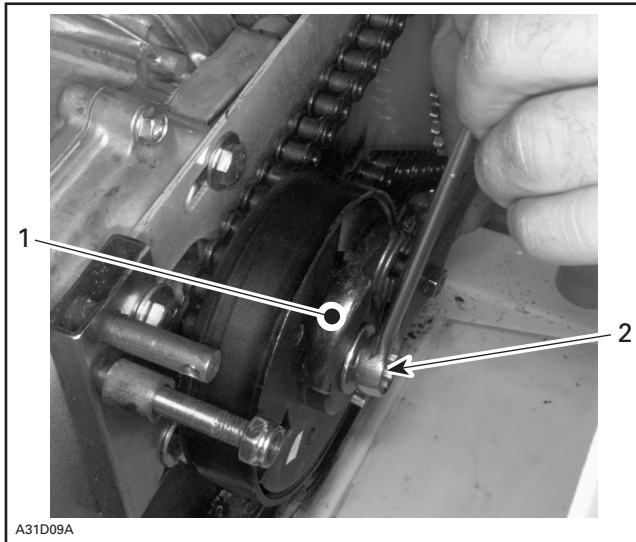

### LOOSEN CLUTCH SCREW

1. Wrench
2. Clutch retaining screw

Remove drive chain automatic tensioner ass'y **no. 4**.

Remove drive chain from drive sprocket.

**NOTE:** To ease drive chain removal, chain can be separated by removing connecting link **no. 5**, as described in subsection 04 DRIVE CHAIN.

Remove clutch with extension **no. 6** and spacer **no. 7**.

## 8, Driven Sprocket Removal

**NOTE:** To ease drive chain and driven sprocket **no. 8** removal and installation, it may be useful to remove footrest.

Remove drive chain from driven sprocket.

Loosen driven sprocket locking nut **no. 9**, then remove driven sprocket screw **no. 10**.

Pull out driven sprocket from drive axle.

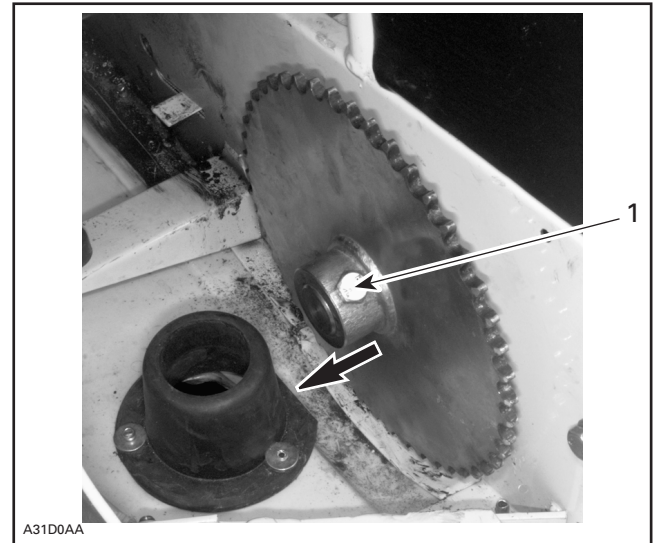

### REMOVE DRIVEN SPROCKET

1. Loosen driven sprocket locking screw

## DISASSEMBLY

Parts are not available separately. If clutch is damaged, replace clutch assembly.

## CLEANING

Clean all metal components in a general purpose solvent. Thoroughly dry all components before assembling.

## INSPECTION

Inspect drive sprocket for wear. If sprocket is worn, replace clutch ass'y with new one.

If so check if clutch components are loose. If so, replace clutch ass'y with new one.

## INSTALLATION

To install clutch, reverse removal procedure paying attention to the following.

Pour a few drops of oil into clutch sleeves, as shown in the next illustration.

**▼ CAUTION**

Pour a few drops of oil on clutch axle only. Do not spill oil into clutch mechanism or on clutch cover (braking surface).

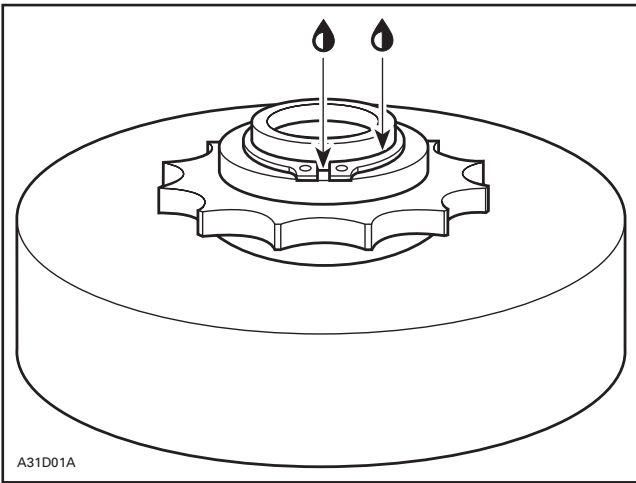

*DRIP A FEW DROPS OF OIL ON CLUTCH AXLE*

To ease sprocket and clutch installation, first install drive chain on both sprockets. Slide clutch and driven sprocket on shafts, as per following photo.

**▼ CAUTION**

Ensure that keyway is properly positioned when sliding clutch on shaft.

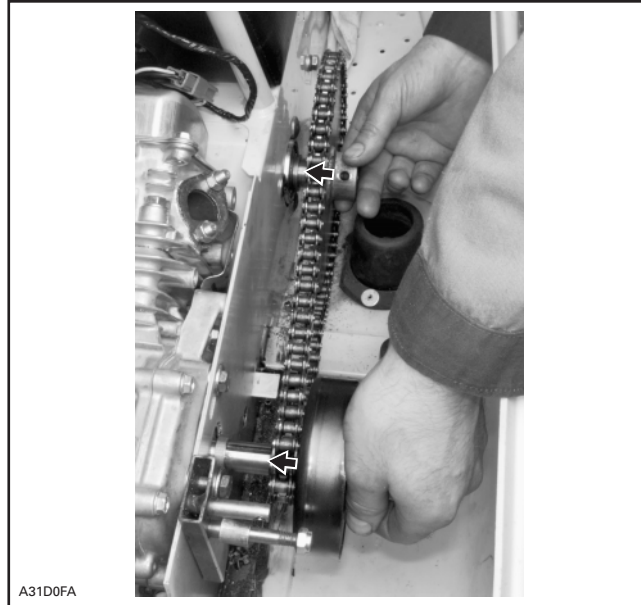

*SLIDE CLUTCH AND DRIVEN SPROCKET*

Secure clutch and driven sprocket.

Reinstall automatic drive chain tensioner.



# BRAKE

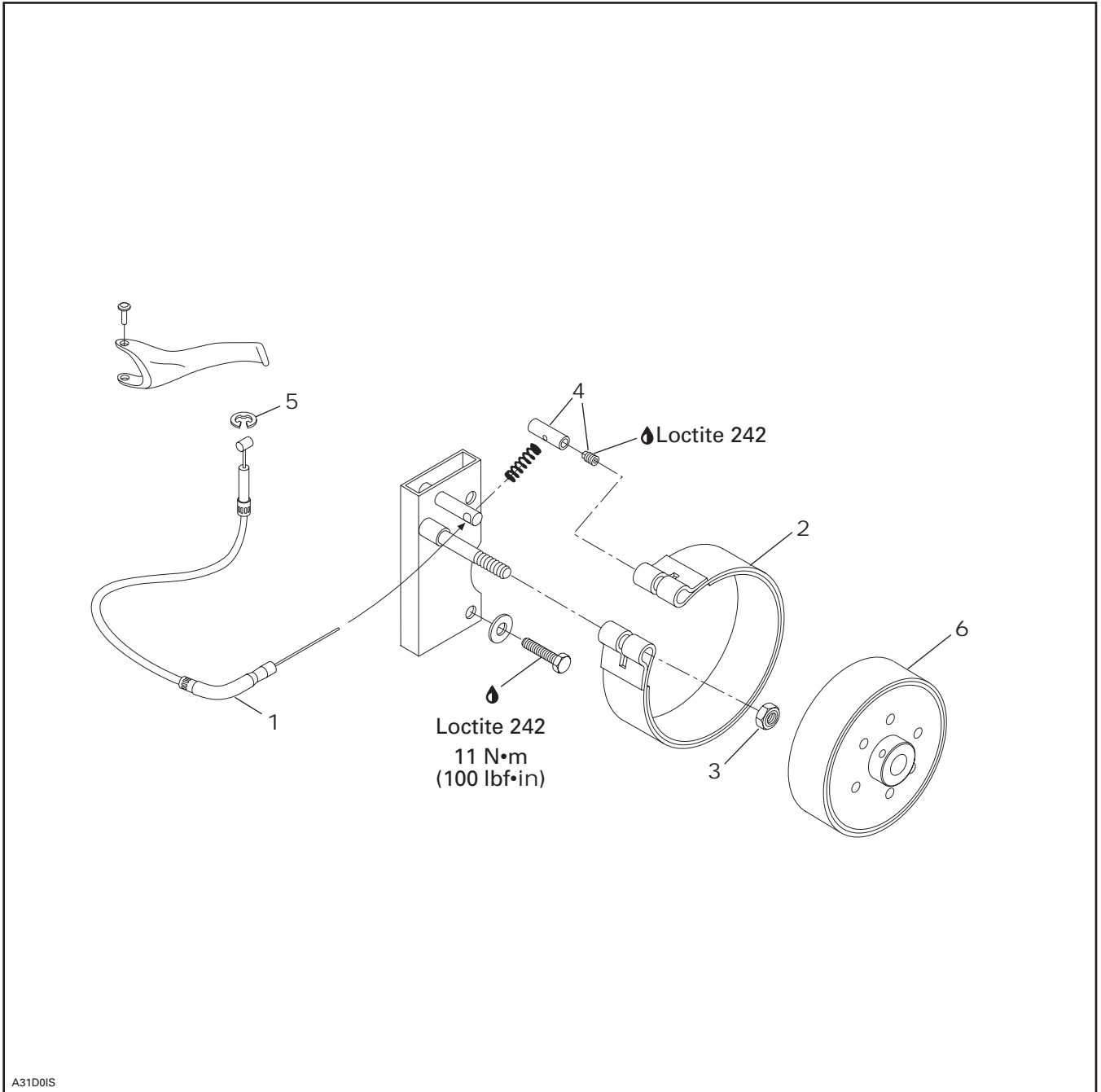

## REMOVAL

### 2, Brake Pad Removal

Using Allen key, unlock brake cable **no. 1** from cable lock **no. 4**, as shown in the next photo.

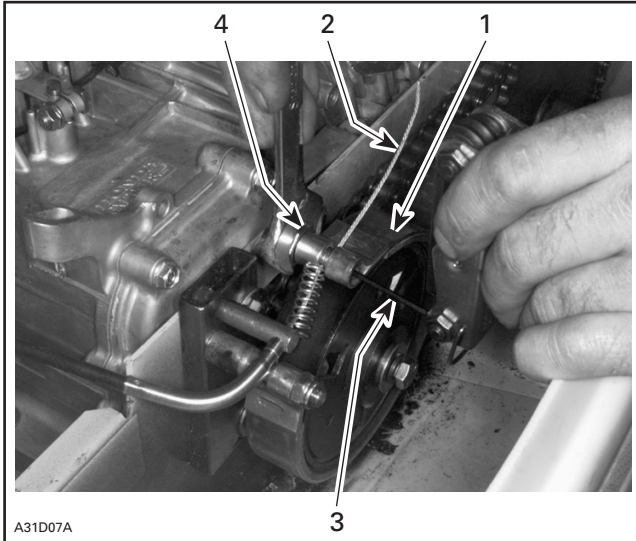

#### UNLOCK BRAKE CABLE FROM BRAKE PAD

1. Brake pad
2. Brake cable
3. Unlock brake cable using Allen key
4. Hold screw head

Pull out brake cable from cable lock.

Remove elastic nut **no. 3** from pivot screw, then pull out brake pad **no. 2**.

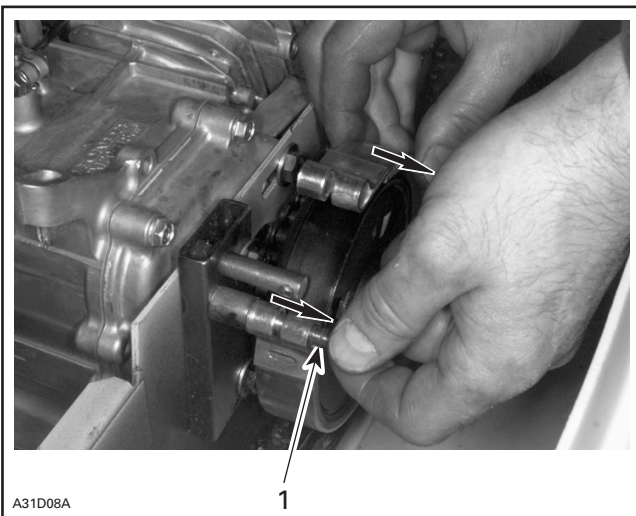

#### REMOVE BRAKE PAD

1. Pivot screw

### Brake Cable Replacement

Remove circlip **no. 5** from brake cable at brake lever location, as shown in the next photo.

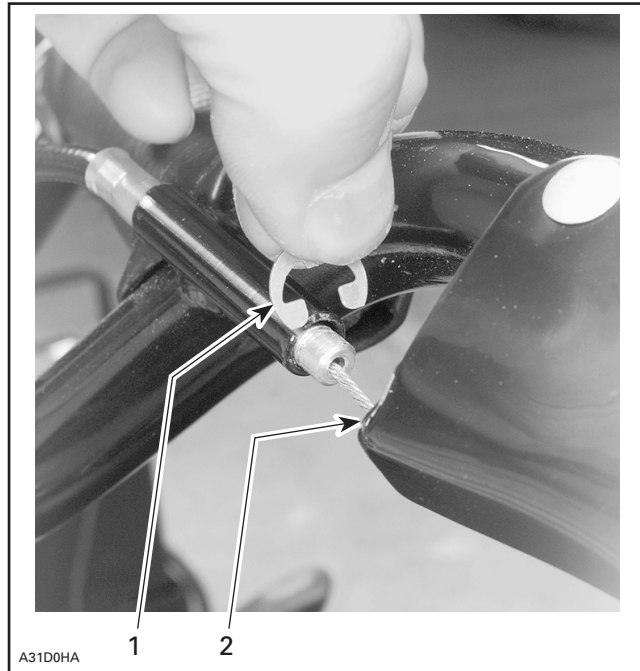

1. Circlip
2. Detach brake cable from brake lever

Detach brake cable from brake lever.

Remove cable and replace with new one.

## DISASSEMBLY

Only brake pad **no. 2** is available as spare part. If clutch cover braking surface is damaged or used, replace clutch ass'y **no. 6**.

## CLEANING

Clean all metal components in a general purpose solvent. Thoroughly dry all components before assembling.

### ▼ CAUTION

Do not clean brake pad in solvent. Soiled brake pad must be replaced by new one.

## INSPECTION

### 2, Brake Pad

Brake pad must be replaced when lining is 1 mm (1/32 in) thick or less.

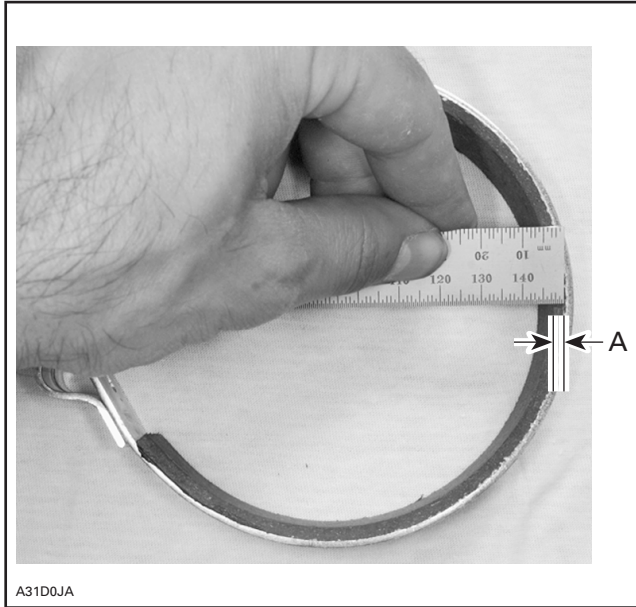

A. 1 mm (1/32 in) minimum

### 6, Brake Drum (clutch cover)

Inspect brake drum surface in clutch cover for scoring, wear or cracking.

If brake drum needs to be replaced, replace clutch assembly with new one.

## INSTALLATION

To install brake pad, reverse removal procedure paying attention to the following.

When securing brake pad with elastic nut **no. 3**. Stop tightening when nut leans against brake pad. This will avoid brake pad damage.

### ◆ WARNING

Avoid getting oil on brake pad.

Check that brake lever is set to normal position (no play), as shown in the next photo.



1. No play here

Using pliers, secure brake cable so that brake pad slightly rests on clutch cover.

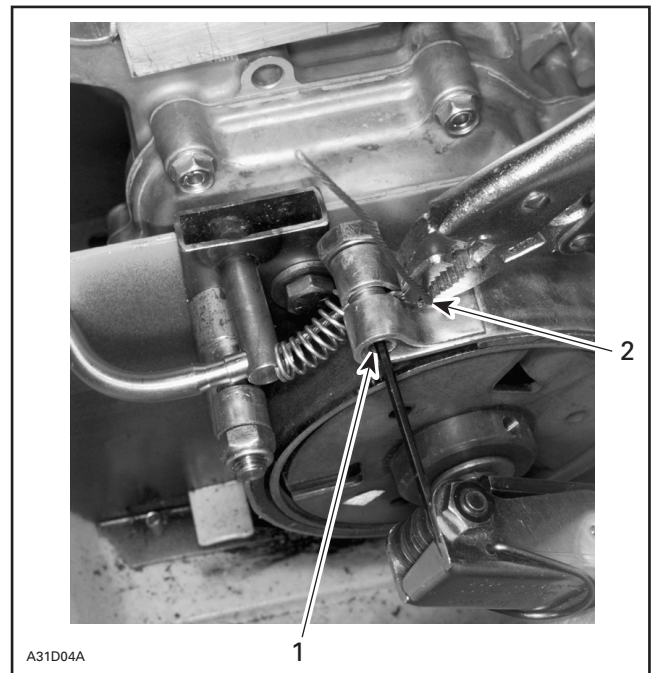

1. Tighten Allen screw  
2. Pull brake cable with pliers

## ADJUSTMENT

Fully apply brake with brake lever. If brake lever is not within 15 mm (19/32 in) to 20 mm (25/32 in) of the handlebar, readjust brake. Refer to the following photo.

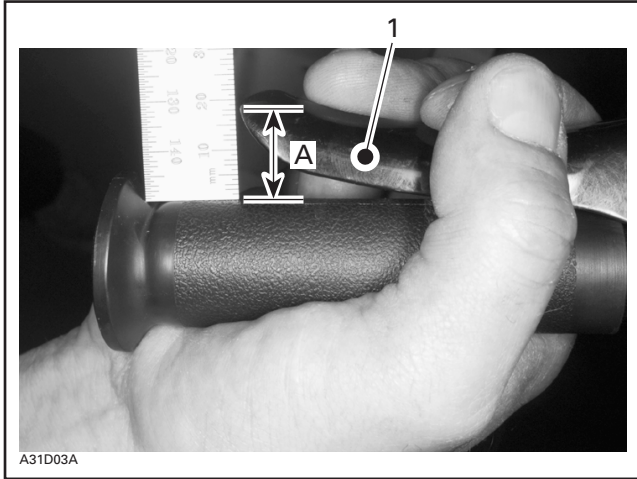

1. Brake lever

A. If measure is not within 15 mm (19/32 in) to 20 mm (25/32 in), readjust brake

To adjust brake, loosen Allen screw then pull or push on brake cable.

Retighten cable lock Allen screw.

Finally check brake adjustment.

# DRIVE CHAIN

## REMOVAL

**NOTE:** To ease drive chain removal, remove drive chain automatic tensioner first.

Rotate drive chain to locate connecting link circlip. Using a flat screwdriver push on both ends of circlip to remove it.

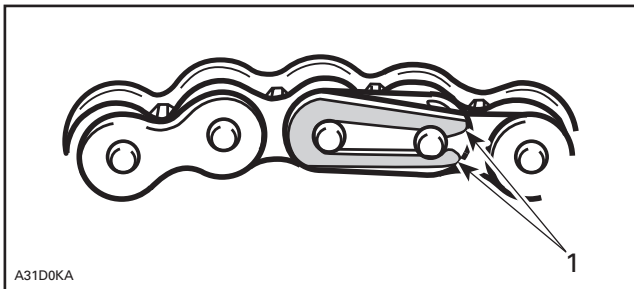

### REMOVE CIRCLIP

1. Using a screwdriver, push circlip here

Remove outer link.

Detach drive chain by removing connecting link.

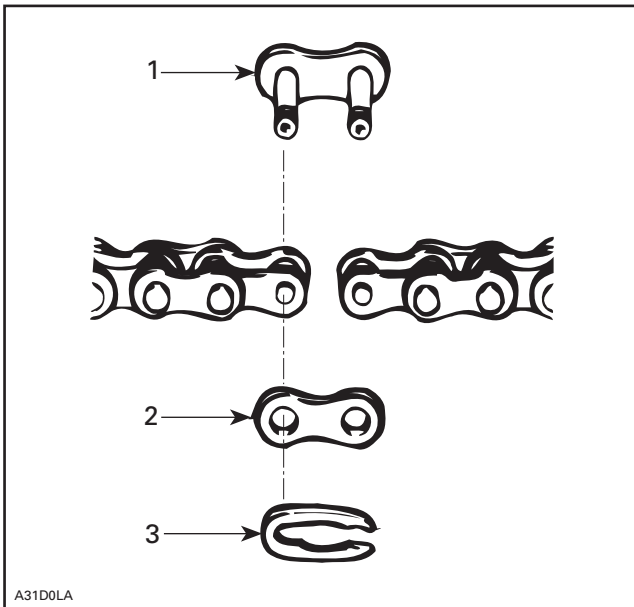

1. Connecting link
2. Outer link
3. Circlip

Keep circlip, outer link and connecting link.

## INSPECTION

Check that chain is not stretched.

### ▼ CAUTION

On a stretched chain, pitch has changed (increased) and will not properly match the sprockets pitch, causing premature wear. For that reason, a stretched chain must never be shortened.

Visually inspect chain for cracked, damaged or missing links.

Check for worn or defective bearings, sprockets and chain tensioner components.

## INSTALLATION

Reinstall drive chain on both sprockets.

Join both drive chain ends using connecting link.

Secure connecting link using outer link and circlip.

Install circlip so that open end is positioned opposite side of drive chain rotation. See the following illustration.

### ◆ WARNING

Always ensure that connecting link, outer link and circlip are in good condition. Ensure that circlip is properly secured.

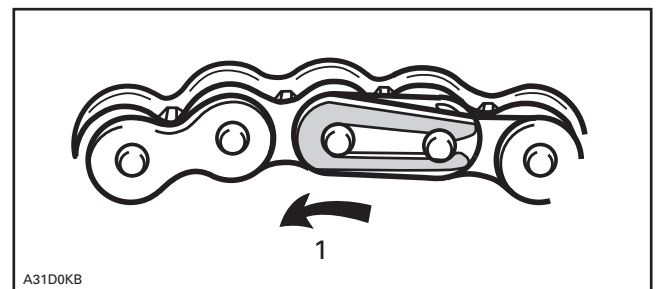

### TYPICAL

1. Rotation

Reinstall drive chain automatic tensioner.

## LUBRICATION

Lubricate drive chain as per lubrication chart.  
Use BOMBARDIER LUBE (P/N 293 600 000).



### **CAUTION**

Always lubricate drive chain slightly. Oil must not contact brake pad.

# TABLE OF CONTENTS

---

<b>SPARK PLUGS</b> .....	<b>06-02-1</b>
<b>NGK SPARK PLUG</b> .....	<b>06-02-1</b>
NGK SPARK PLUG NUMBERING SYSTEM .....	06-02-1
REFERENCE CHART .....	06-02-1
<b>DESIGN SYMBOLS USED IN NGK SPARK PLUGS</b> .....	<b>06-02-2</b>
DISASSEMBLY.....	06-02-3
HEAT RANGE .....	06-02-3
FOULING .....	06-02-3
SPARK PLUG ANALYSIS.....	06-02-3
SPARK PLUG INSTALLATION.....	06-02-4
SPARK PLUG TIGHTENING TORQUE .....	06-02-4
<hr/>	
<b>TESTING PROCEDURE</b> .....	<b>06-03-1</b>
IGNITION SYSTEM TESTING SEQUENCE .....	06-03-1
LIGHTING SYSTEM TESTING SEQUENCE.....	06-03-1
1. SPARKING .....	06-03-1
2. ELECTRICAL CONNECTOR TESTING .....	06-03-1
3. IGNITION COIL TESTING.....	06-03-1
4. SPARK PLUG CAP TESTING.....	06-03-2
5. LAMP COIL TESTING .....	06-03-3

# SPARK PLUGS

## NGK SPARK PLUG

### NGK SPARK PLUG NUMBERING SYSTEM

Bombardier uses the NGK spark plug brand on all its snowmobile models.

The heat range identification system is:

Low number —————▶ hot plug

High number —————▶ cold plug

### REFERENCE CHART

NGK spark plug used on Bombardier Mini Z snowmobile is covered in this manual:

- BPR6 ES



## DESIGN SYMBOLS USED IN NGK SPARK PLUGS

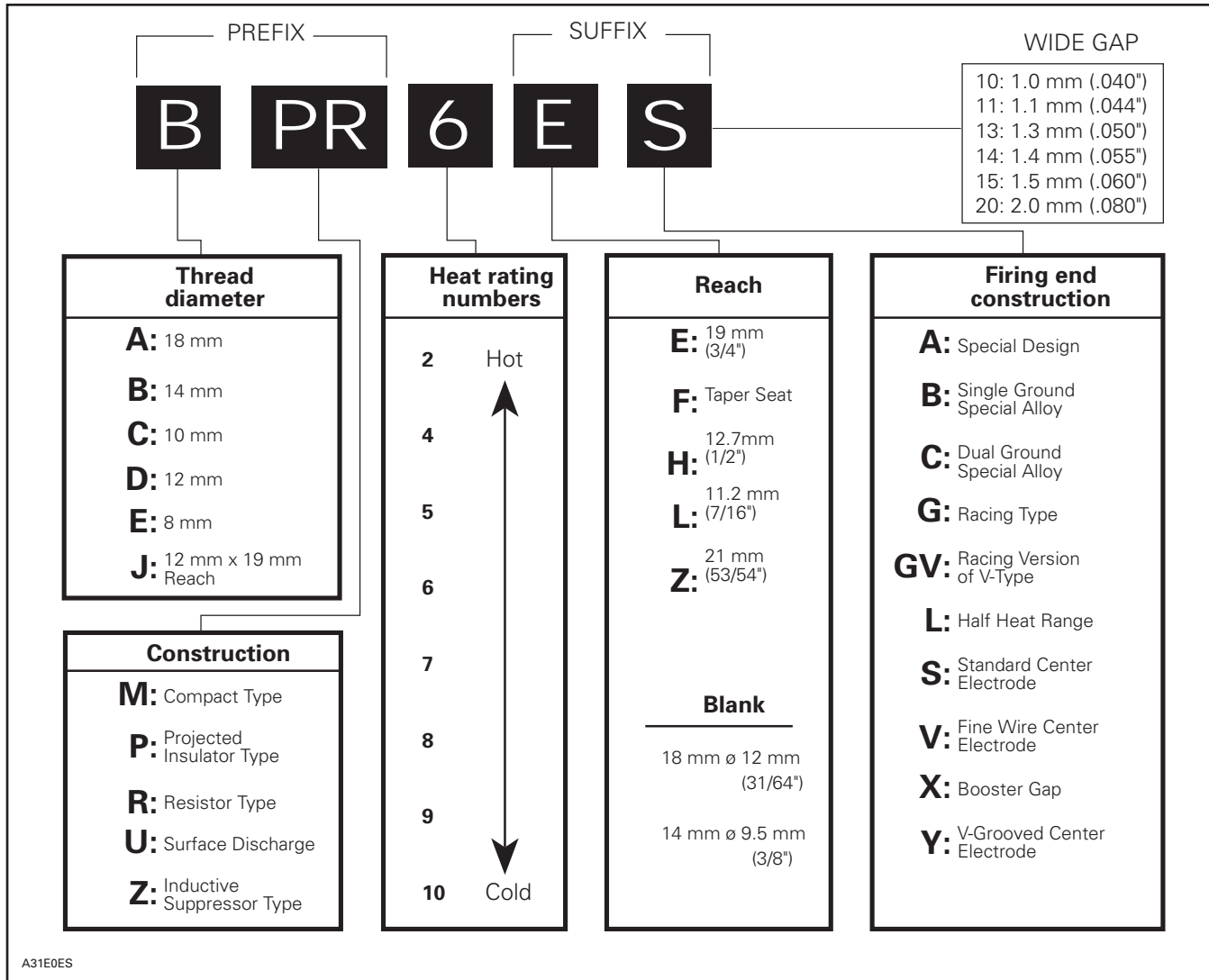

### CROSSCUTS AND GAP STYLES OF SPARK PLUGS

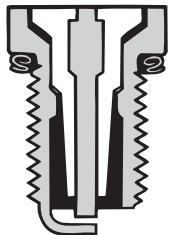

Standard Type

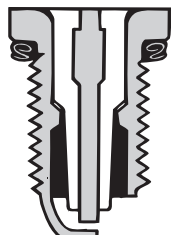

Projected Insulator Type



Taper Seat Type

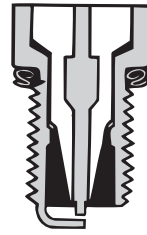

V-Type

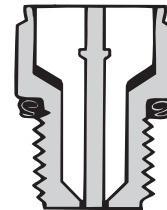

Surface Discharge Type

A01E1PS

## DISASSEMBLY

First unscrew the spark plug 1 turn.

Clean the spark plug and cylinder head with pressurized air, then completely unscrew.

### ◆ WARNING

Whenever using compressed air, always wear protective eye wear.

## HEAT RANGE

The proper operating temperature or heat range of the spark plugs is determined by the spark plug ability to dissipate the heat generated by combustion.

The longer the heat path between the electrode tip to the plug shell, the hotter the spark plug operating temperature will be — and inversely, the shorter the heat path, the colder the operating temperature will be.

A “cold” type plug has a relatively short insulator nose and transfers heat very rapidly into the cylinder head.

Such a plug is used in heavy duty or continuous high speed operation to avoid overheating.

The “hot” type plug has a longer insulator nose and transfers heat more slowly away from its firing end. It runs hotter and burns off combustion deposits which might tend to foul the plug during prolonged idle or low speed operation.

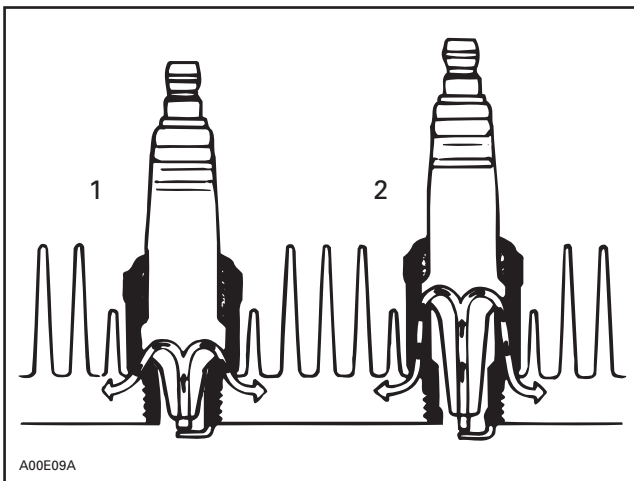

1. Cold  
2. Hot

### ▼ CAUTION

Severe engine damage might occur if a wrong heat range plug is used.

A too “hot” plug will result in overheating and pre-ignition, etc.

A too “cold” plug will result in fouling (shorting the spark plug) or may create carbon build up which can heat up red-hot and cause pre-ignition or detonation.

## FOULING

Fouling of the spark plug is indicated by irregular running of the engine, decreased engine speed due to misfiring, reduced performance, and increased fuel consumption. This is due to a loss of compression. Other possible causes are: prolonged idling, or running on a too rich mixture due to a faulty carburetor adjustment or incorrect fuel and/or fuel mixing. The plug face of a fouled spark plug has either a dry coating of soot or an oily, glossy coating given by an excess either of oil or of oil with soot. Such coatings form a conductive connection between the center electrode and ground.

## SPARK PLUG ANALYSIS

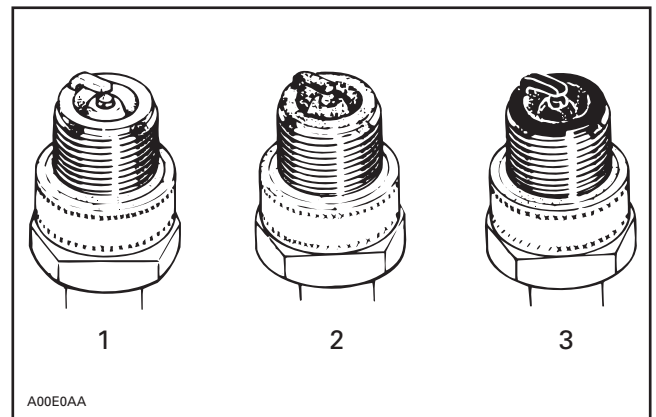

1. Overheated (light grey)  
2. Normal (brownish)  
3. Fouled (black)

The plug electrode and piston dome reveal the condition of the engine, operating condition, method of driving and fuel mixture. For this reason it is advisable to inspect the spark plug at regular intervals, examining the plug electrode and the piston dome.

---

## Section 06 ELECTRICAL

### Subsection 02 (SPARK PLUGS)

---

## SPARK PLUG INSTALLATION

Prior to installation make sure that contact surfaces of the cylinder head and spark plug are free of grime.

1. Using a wire feeler gauge, set electrode gap according to TECHNICAL DATA 10.
2. Apply anti-seize lubricant (P/N 413 701 000) over the spark plug threads to prevent possible seizure.
3. Hand screw spark plug into cylinder head and tighten with a torque wrench and a proper socket.

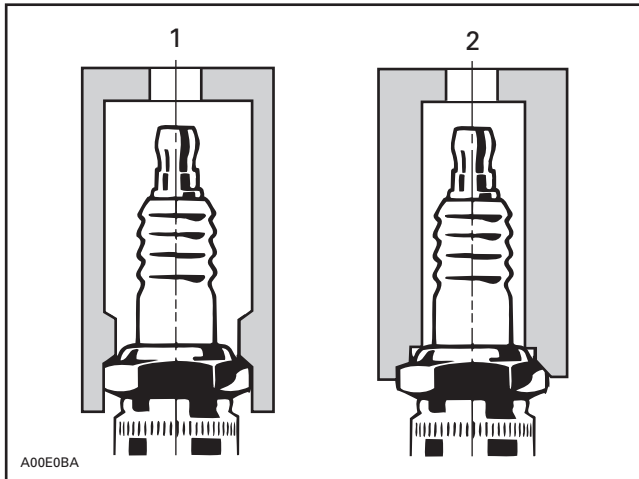

1. *Proper socket*
2. *Improper socket*

## SPARK PLUG TIGHTENING TORQUE

MODELS	SPARK PLUGS	TORQUE N•m (lbf•ft)
All models	NGK	27 (20)

# TESTING PROCEDURE

## IGNITION SYSTEM TESTING SEQUENCE

In the case of ignition problems, check the following in the prescribed order until the problem can be solved.

1. Sparking/spark plug condition
2. Electrical connectors
3. Ignition switches, tether cord cap switch and emergency switch
4. Ignition coil resistance

## LIGHTING SYSTEM TESTING SEQUENCE

1. Electrical connectors
2. Lamp coil resistance

### Analysis of Readings

#### Resistance Readings

Place multimeter selector switch to  $\Omega$  in order to measure resistance. Readings must be within the indicated range. Otherwise, the part is considered to be defective and must be replaced.

### ▼ CAUTION

When taking measurements, it is useless to try to start the vehicle since readings would then be distorted.

### Intermittent Ignition Problems

It is difficult to make a diagnostic in the case of intermittent ignition problems. Thus, problems occurring only when the engine operating temperature is normal must be checked in similar conditions.

In most cases when problems are caused by temperature or vibrations, these can only be solved by replacing parts. Most problems cannot be detected when the engine is stopped.

### Multiple Problems

As a matter of fact, more than one component can be defective. As a result, if the problem remains although a part was replaced, start over the whole verification from the beginning in order to identify the other defective component.

## 1. SPARKING

During this operation, it is important to use the snowmobile spark plug and not a new one. Bring the plug in contact with the engine. If no spark is produced, replace the spark plug with a new one and do the test again.

## 2. ELECTRICAL CONNECTOR TESTING

Make sure that none of the connectors are disconnected.

## 3. IGNITION COIL TESTING

### Primary Side

Bring multimeter selector switch to  $\Omega$  position.

Connect first multimeter probe to ignition coil primary black wire then second probe to ignition coil iron core, as shown in the next photo.

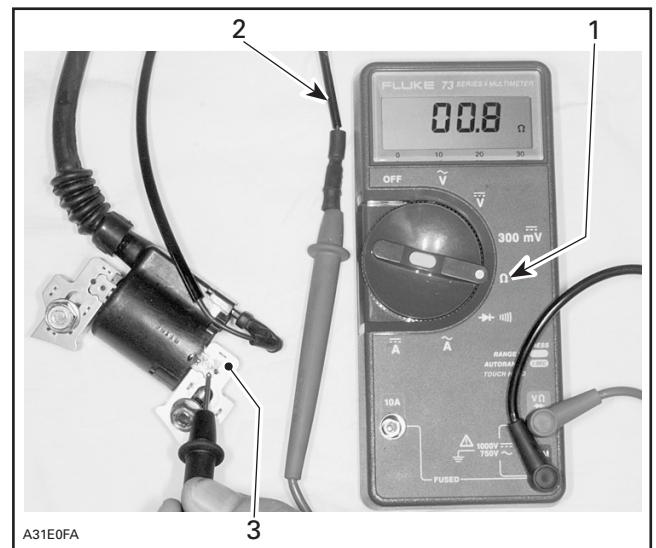

#### PRIMARY SIDE TESTING

1. Multimeter to  $\Omega$  position
2. Ignition coil primary black wire
3. Ignition coil iron core

Section 06 ELECTRICAL  
 Subsection 03 (TESTING PROCEDURE)

The measured resistance should be according to the following table. If not, replace ignition coil.

PRIMARY SIDE RESISTANCE VALUE	0.8 - 1.0 $\Omega$
----------------------------------	--------------------

### Secondary Side

Bring multimeter selector switch to  $\Omega$  position.

Remove spark plug cap by unscrewing cap from cable.

**NOTE:** A false resistance reading will result if spark plug cap is not removed.

Connect first multimeter probe to spark plug lead wire then second probe to ignition coil iron core, as shown in the next photo.

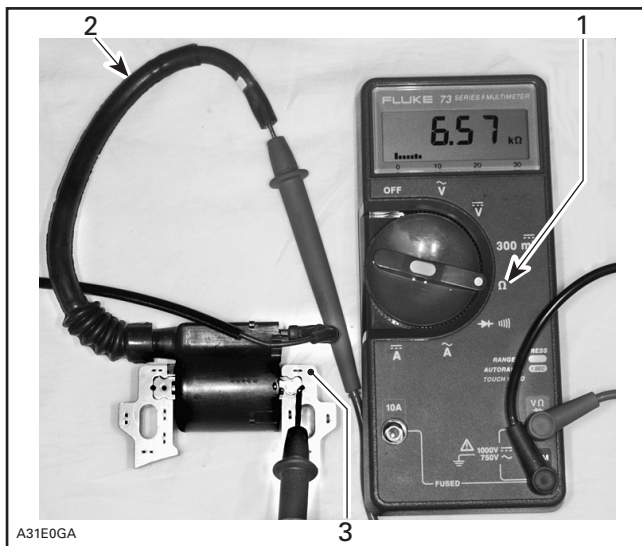

#### SECONDARY SIDE TESTING

1. Multimeter to  $\Omega$  position
2. Spark plug lead wire
3. Ignition coil iron core

The measured resistance should be according to the following table. If not, replace ignition coil.

SECONDARY SIDE RESISTANCE VALUE	5.9 - 7.1 $k\Omega$
------------------------------------	---------------------

## 4. SPARK PLUG CAP TESTING

Remove spark plug cap by unscrewing cap from cable.

**NOTE:** A false resistance reading will result if spark plug cap is not removed.

Bring multimeter selector switch to  $\Omega$  position.

Connect first multimeter probe to one end of the spark plug cap then second probe to the other end as shown in the next photo.

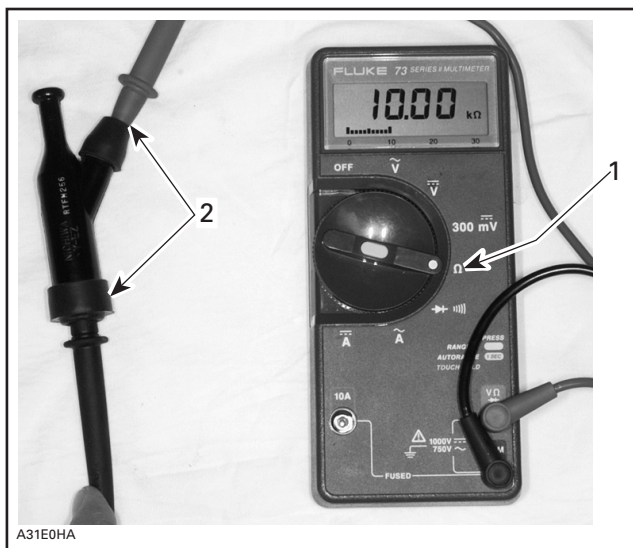

#### SPARK PLUG CAP TESTING

1. Multimeter to  $\Omega$  position
2. Spark plug cap end

The measured resistance should be according to the following table. If not, replace spark plug cap.

RESISTANCE	7.5 - 12.5 $k\Omega$
------------	----------------------

## 5. LAMP COIL TESTING

**NOTE:** Lamp coil is parallel 2 coils type.

Bring multimeter selector switch to  $\Omega$  position.

Connect first multimeter probe to pink wire then second probe to lamp coil iron core, as shown in the next photo.

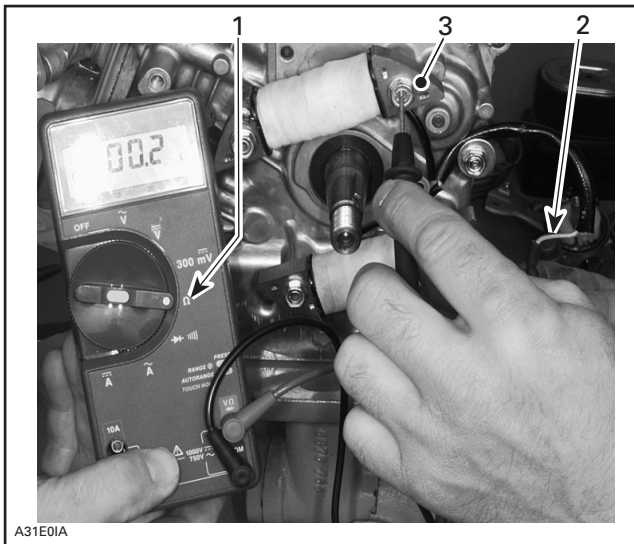

### LAMP COIL TESTING

1. Multimeter to  $\Omega$  position
2. Pink wire
3. Lamp coil iron core

The measured resistance should be according to the following table. If not, replace lamp coil.

RESISTANCE	0.18 - 0.23 $\Omega$
------------	----------------------

# TABLE OF CONTENTS

---

<b>REAR SUSPENSION</b> .....	<b>07-02-1</b>
REMOVAL .....	07-02-2
DISASSEMBLY AND ASSEMBLY.....	07-02-3
INSPECTION .....	07-02-5

---

<b>DRIVE AXLE</b> .....	<b>07-03-1</b>
REMOVAL.....	07-03-2
DISASSEMBLY AND ASSEMBLY .....	07-03-3
INSTALLATION .....	07-03-3

---

<b>TRACK</b> .....	<b>07-04-1</b>
GENERAL .....	07-04-1
INSPECTION .....	07-04-1
REMOVAL.....	07-04-1
INSTALLATION .....	07-04-1

# REAR SUSPENSION

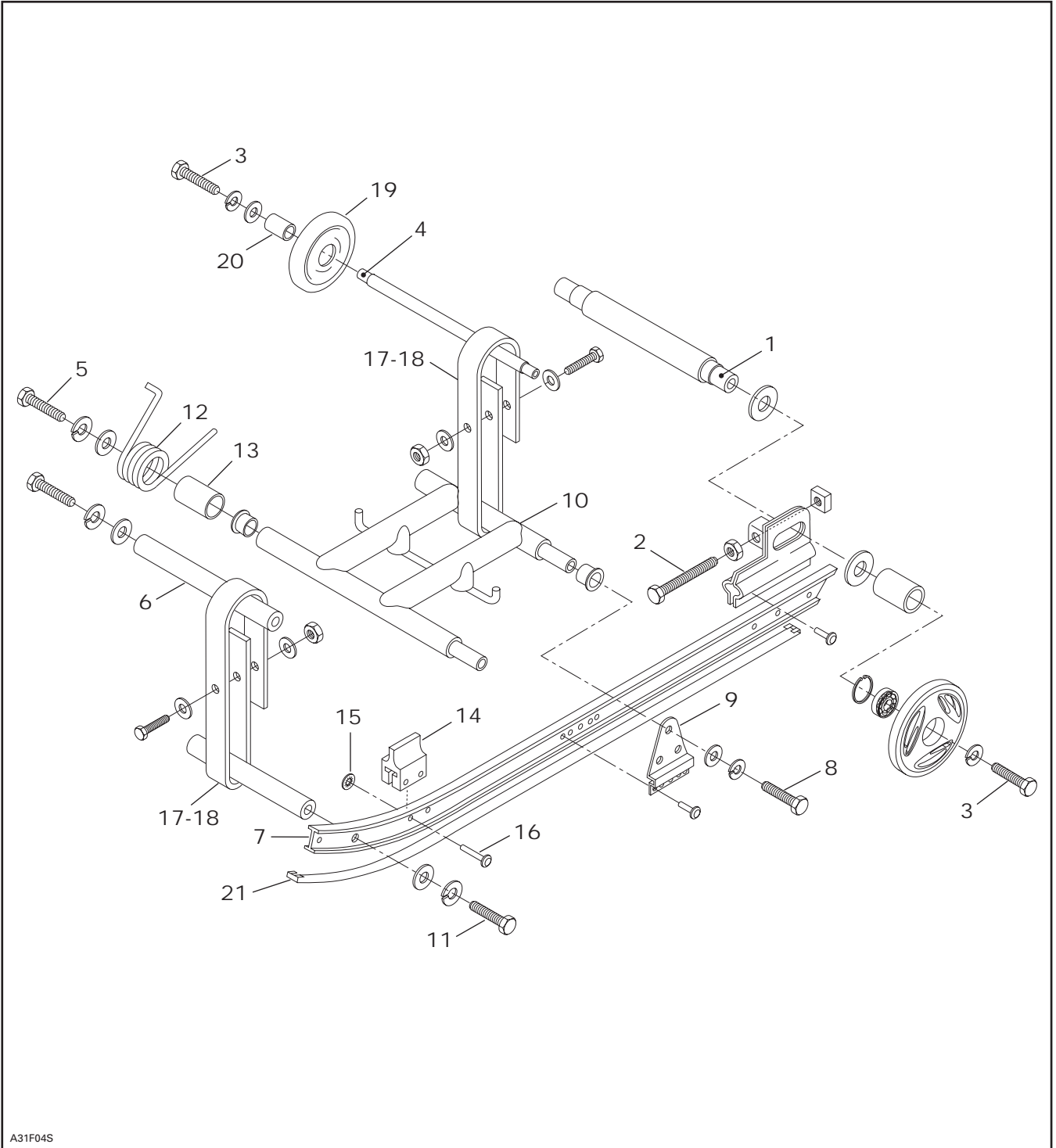

A31F04S



## Section 07 REAR SUSPENSION

### Subsection 02 (REAR SUSPENSION)

**NOTE:** The following is the complete procedure to remove rear suspension ass'y. However some suspension components can be removed without removing suspension ass'y. See DISASSEMBLY AND ASSEMBLY procedure.

## REMOVAL

Lift rear of snowmobile and support it off the ground.

### 1, Rear Axle

**NOTE:** Removing rear axle first will ease rear suspension ass'y removal.

Completely release track tension by loosening adjustment screws **no. 2**.

Unscrew one rear idler wheel screw **no. 3**.

Pull out rear axle **no. 1** from opposite side of off-set inner wheel.

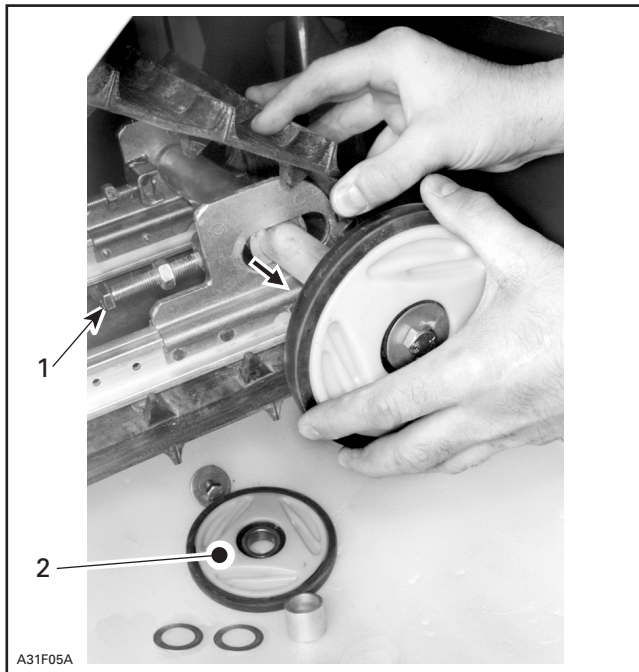

#### PULL OUT REAR AXLE

1. Loosen this adjustment screw on both sides to release track tension
2. Idler wheel previously removed

## Rear Suspension

Position a small block below track.

Lower snowmobile so that track sits on block.



#### POSITION A SMALL BLOCK BELOW TRACK

Lean on snowmobile seat then unscrew upper idler wheel axle **no. 4** from tunnel.



1. Unscrew upper idler wheel axle

Remove both screws **no. 5** retaining front arm to tunnel.

Unscrew front retainer axle **no. 6** (retaining front strap) from tunnel. See the following photo.

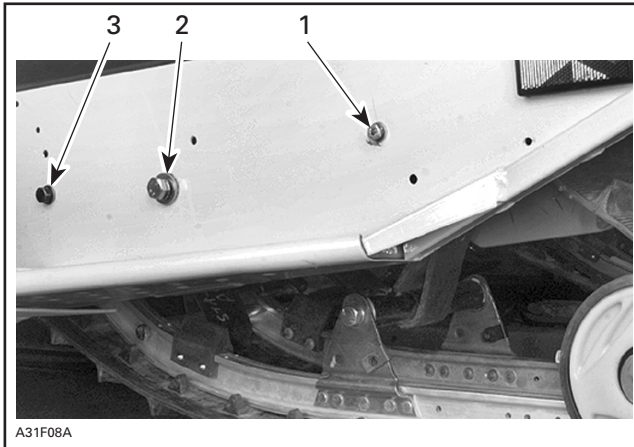

1. Upper idler wheel screw
2. Front arm screw
3. Front retainer axle screw

Lift rear of snowmobile.

Pull out suspension ass'y.

## DISASSEMBLY AND ASSEMBLY

Inspect track thoroughly before reinstalling suspension. Refer to TRACK 07-04.

### 7, Runner

**NOTE:** Runner **no. 7** can be removed without removing suspension assembly, as described in the following procedure.

Lift rear of snowmobile.

Completely released track tension.

Remove rear axle **no. 1** with idler wheels.

Remove screws **no. 8** retaining runner support **no. 9** to front arm **no. 10**, as shown in the following photo.



**REMOVE SCREW**

Remove front axle screw **no. 11**, as shown in the following photo.



**REMOVE SCREW**

Section 07 REAR SUSPENSION  
Subsection 02 (REAR SUSPENSION)

Pull out runner from track, as shown in the next photo.



A31F0BA  
**PULL OUT RUNNER**

To reinstall runner, reverse removal procedure.

## 12, Torsion Spring

**NOTE:** Torsion springs can be replaced without completely removing rear suspension ass'y, as described in the following procedure.

Lift rear of snowmobile.

Completely released track tension.

Remove rear axle **no. 1** with idler wheels.

Lower snowmobile.

Lean on snowmobile seat then unscrew upper idler wheel axle **no. 4** from tunnel.



A31F07A  
1. **Unscrew upper idler wheel axle**

Remove both screws **no. 5** retaining front arm to tunnel.

Lift rear of snowmobile so that rear suspension ass'y comes out of tunnel.

Remove torsion spring **no. 12**, as shown in the next photo.



A31F0CA  
**REMOVE TORSION SPRING**

Remove bushing **no. 13**, as shown in the next photo. Clean all surfaces and check for excessive wear.



**REMOVE AND CLEAN BUSHING**

To reinstall, reverse removal procedure.

### 14,15,16, Stopper Rubber

**NOTE:** Stopper rubber **no. 14** can be replaced with runner and suspension ass'y in place.

Using special tool Snap-on A161B, remove push nuts **no. 15** as shown in the next photo.

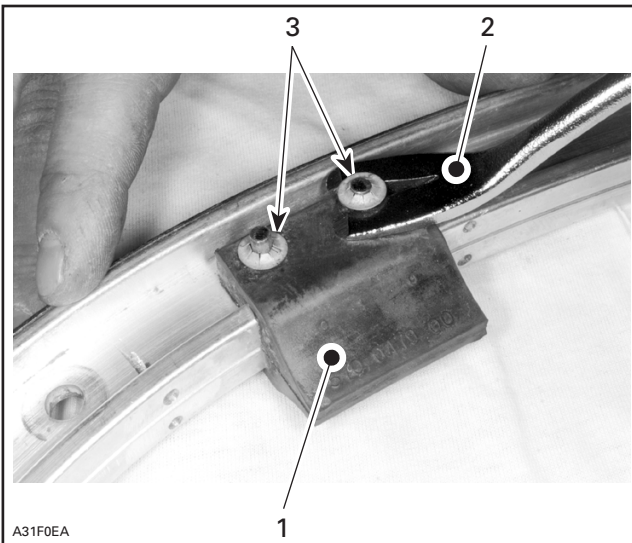

1. Stopper rubber
2. Special tool Snap-on A161B
3. Push nuts

Remove retaining pins **no. 16**.  
Lift stopper rubber tab and remove it.

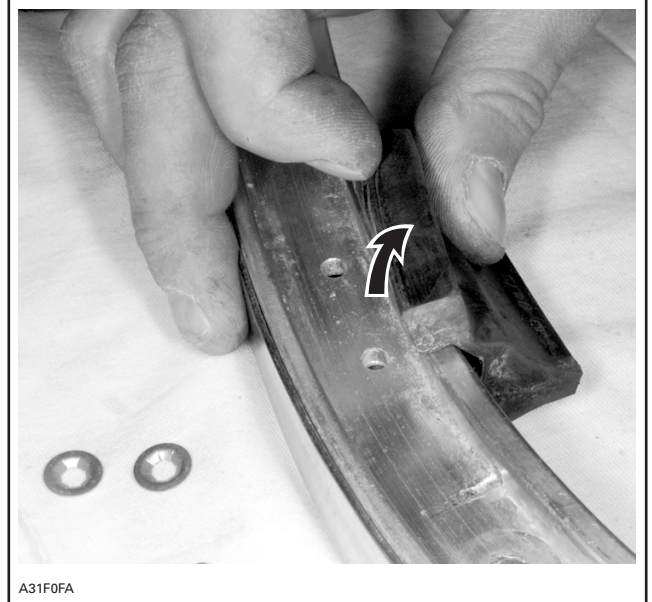

**REMOVE STOPPER RUBBER**

Reinstall stopper rubber **no. 14** with retaining pins **no. 16** and push nuts **no. 15**.

### ▼ CAUTION

When reusing original push nuts, ensure that they are in good condition. If not, replace with new push nuts.

### INSPECTION

#### 17,18, Stopper Straps

Inspect straps for wear or cracks, bolts and nuts for tightness. If nuts are loose, inspect hole for deformation. Replace as required.

Section 07 REAR SUSPENSION  
Subsection 02 (REAR SUSPENSION)



TYPICAL — FRONT STRAP SHOWN

1. Inspect bolts and nuts for tightness

## 19,20, Upper Idler Wheels

Remove bushing **no. 20** and idler wheel **no. 19** from shaft **no. 4**, as shown in the next photo.

Clean parts and check for wear and bearing condition.



CHECK BUSHING, WHEEL AND SHAFT CONDITION

## 21, Slider Shoe

Inspect slider shoes **no. 21** for wear.

▼ **CAUTION**

If only one slider shoe needs to be replaced, always replace both one. Slider shoes must always be replaced in pairs.

To replace slider shoes:

- Remove left side runner.
- Bend tabs from used slider shoe then remove it.
- Install new slider shoe on one end of the runner, then clip second end.
- Secure slider shoe by bending tabs onto runner.
- Repeat procedure on right side.



Section 07 REAR SUSPENSION  
Subsection 03 (DRIVE AXLE)

## REMOVAL

Remove chain guard.

Remove drive chain then remove driven sprocket.

**NOTE:** To ease driven sprocket and drive axle removal, it may be useful to remove left side foot-rest.

Remove rear suspension. Refer to REAR SUSPENSION 07-02 of this manual.

### Sprocket

From inside tunnel, remove spring pin **no. 1** from right side sprocket using a hammer and a punch, as shown.



A31D00A

REMOVE SPRING PIN

Using a prybar and a piece of wood (to protect tunnel), slide right side sprocket **no. 2** (38 mm (1-1/2 in)). See the next photo.

**NOTE:** Apply BOMBARDIER LUBE (P/N 293 600 016 — 12 x 14 oz) on drive axle to ease sliding sprocket.

## CAUTION

When using prybar, ensure not to apply too much pressure on tunnel wall in order to avoid damaging tunnel.



A31D0PA

SLIDE RIGHT SIDE SPROCKET INSIDE

### Bearing Holder

Using Allen key loosen set screw **no. 3** from bearing lock sleeve **no. 4**, as shown in the next photo.

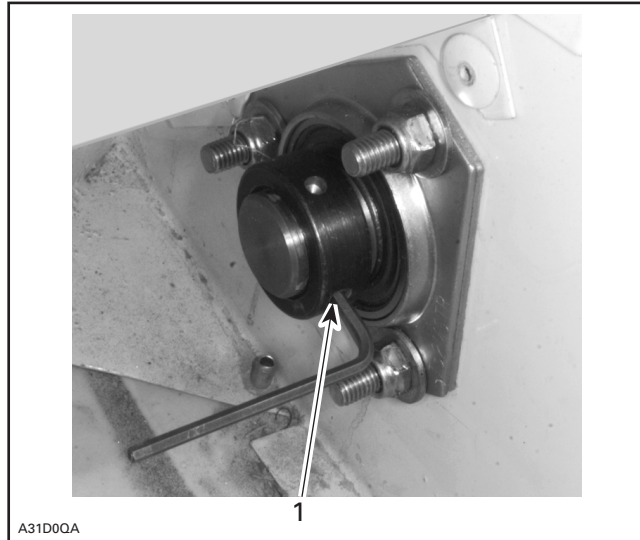

A31D00A

RIGHT SIDE SHOWN

1. Loosen set screw

Using a hammer and a punch, turn CCW to unlock bearing lock sleeve as shown.

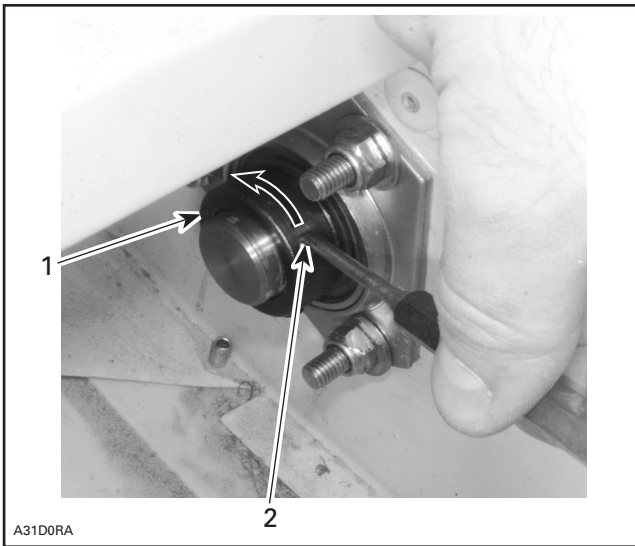

1. Lock sleeve
2. Position punch in this hole

Remove 3 bearing holder nuts **no. 5** and screws **no. 6** then detach both halves **no. 7** using a flat screwdriver. See the following photo.



**DETACH BEARING HOLDER HALVES**

Repeat procedure for left side bearing, except for lock sleeve.

### Drive Axle Ass'y

Pull out drive axle ass'y **no. 8**, as shown in the next photo.

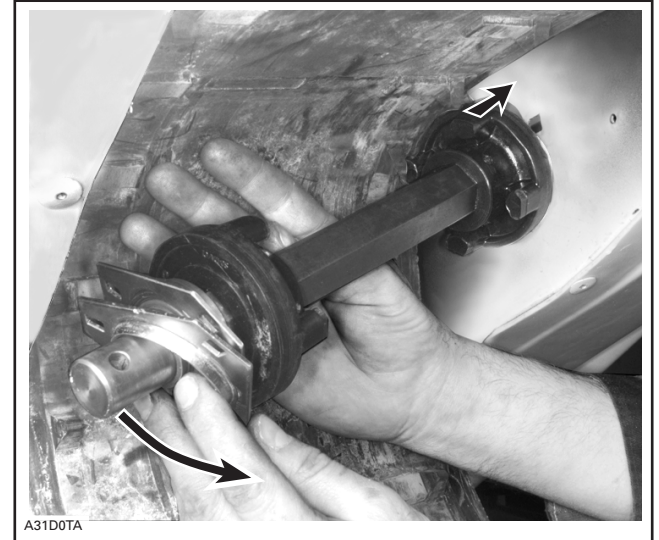

**PULL OUT DRIVE AXLE ASS'Y**

## DISASSEMBLY AND ASSEMBLY

### Bearing and Sprocket

To remove or to install bearings **no. 9** and sprockets **no. 2**, use a press.

### ▼ CAUTION

Ensure that bearings and sprockets are properly supported near hub and that spring pins have been removed from sprockets, before removal.

### INSTALLATION

Reverse the removal procedure and pay a special attention to the following points.

Sprockets can be positioned with drive axle in place. In that case use drive axle sprocket adjuster (P/N 861 725 700), as shown in the following photo.



Section 07 REAR SUSPENSION  
Subsection 03 (DRIVE AXLE)

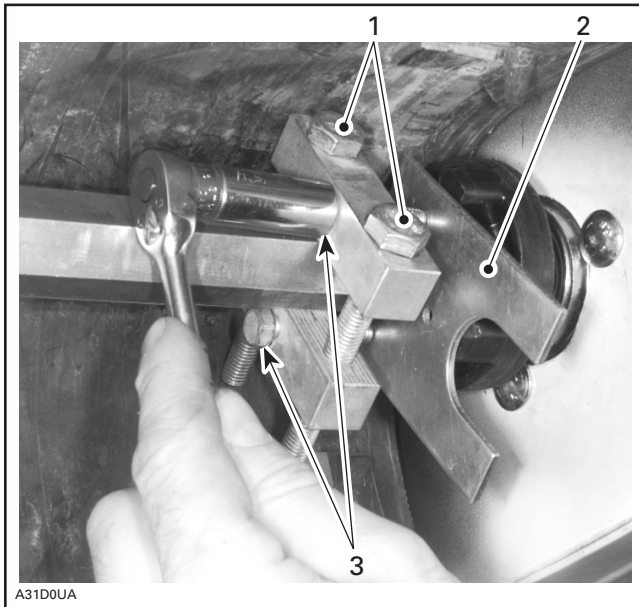

1. Tighten tool on drive axle with these screws
2. Install plate to protect sprocket
3. Use these screws to move sprocket

Reinstall spring pins as shown in the next photo.

▼ **CAUTION**

Ensure that drive axle spring pin hole is properly aligned with sprocket hole.



**REINSTALL SPRING PIN**

### Drive Axle Alignment

To ensure that drive axle sprockets are properly aligned with track guides, measure right side drive axle end.

Measure must be 12 mm (15/32 in) with bearing lock sleeve flange, as shown in the next photo. If not, realign drive axle.

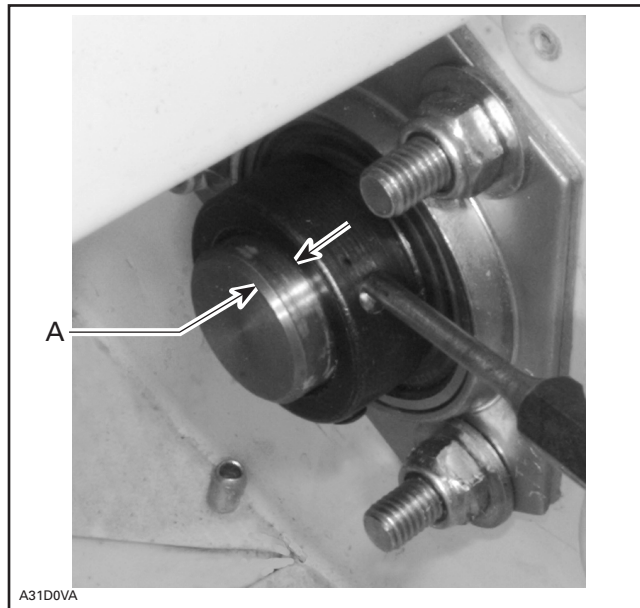

A. 12 mm (15/32 in)

Tighten bearing lock sleeve and secure with set screw. Apply Loctite 242 on set screw thread.

# TRACK

## GENERAL

This section gives guidelines for track removal. Some components require more detailed disassembly procedures. In these particular cases, refer to the pertaining section in this manual.

## INSPECTION

Visually inspect track for:

- cuts and abnormal wear
- missing or defective inserts or guides

If track is damaged, replace track.

### ◆ WARNING

Do not operate a snowmobile with a cut, torn or damaged track.

## REMOVAL

Remove the following items:

- chainguard
- drive chain and driven sprocket
- rear suspension
- end bearing housing
- drive axle
- track

## INSTALLATION

Reverse the removal procedure.

**NOTE:** When installing the track, respect rotation direction indicated by shaped arrows on track thread.

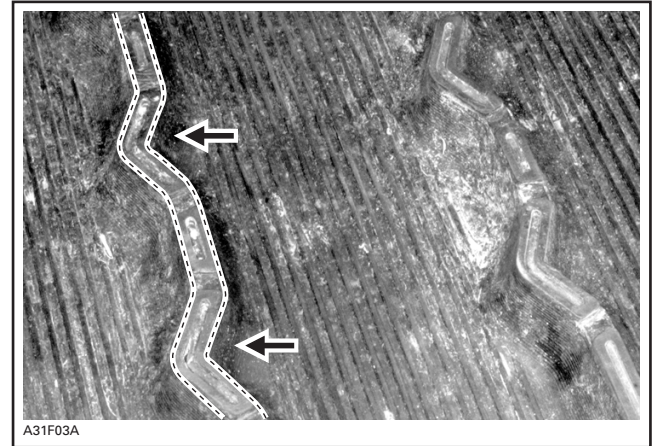

TRACK ROTATION

## Track Tension and Alignment

Track tension and alignment are interrelated. Do not adjust one without checking the other. Track tension procedure must be carried out prior to track alignment.

### Tension

Lift the rear of vehicle and support with a mechanical stand. Allow the suspension to extend normally. Check the gap 60 mm (2-3/8 in) from rear idler wheel bracket.

Deflection should be 35 mm (1-3/8 in) between slider shoe and bottom inside of track, when exerting a downward pull of 7.3 kg (16 lb).

Both track tension gauge (P/N 529 021 500) or tension tester (P/N 414 348 200) can be used to measure deflection as well as force applied.

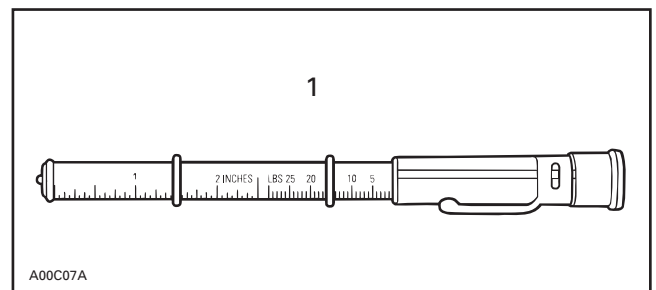

1. Belt tension tester

Section 07 REAR SUSPENSION  
 Subsection 04 (TRACK)

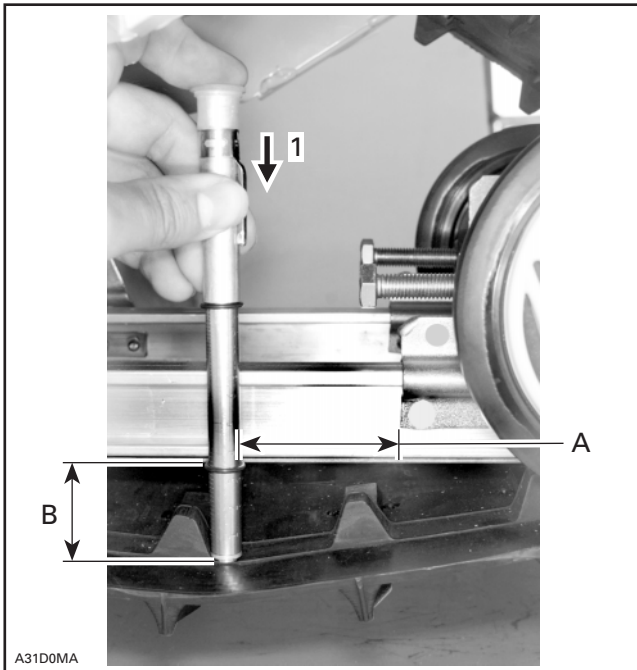

A31D0MA

- 1. 7.3 kg (16 lb)
- A. 60 mm (2-3/8 in)
- B. 35 mm (1-3/8 in)

**CAUTION**

Too much tension will result in power loss and excessive stress on suspension components. If too loose, the track will have a tendency to thump.

To adjust, loosen the rear idler wheel retaining screws and the adjustment screw lock nuts; then loosen or tighten the adjustment screws located on the inner side of the rear idler wheels.

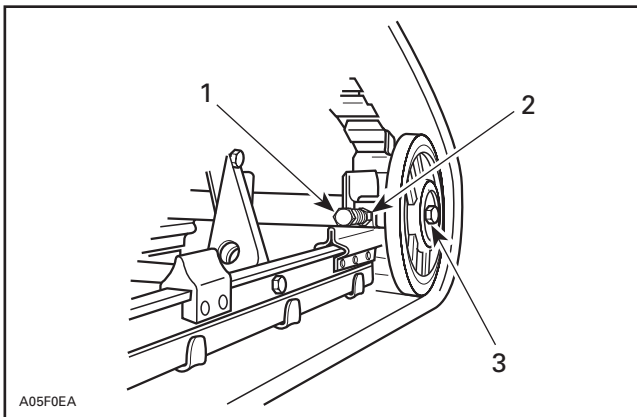

A05F0EA

**TYPICAL**

- 1. Adjustment screw
- 2. Lock nut
- 3. Retaining screw

**Alignment**

**WARNING**

Before checking track tension, ensure that the track is free of all particles which could be thrown out while it is rotating. Keep hands, tools, feet and clothing clear of track. Ensure no one is standing in close proximity to the vehicle.

With rear of vehicle supported off the ground, start engine and allow the track to rotate **slowly**.

Check that the track is well centered; equal distance on both sides between edges of track guides and slider shoes.

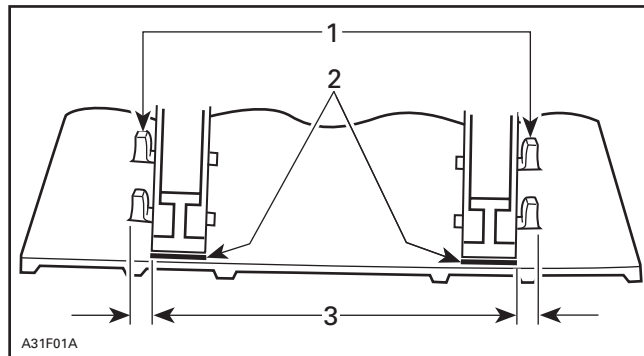

A31F01A

- 1. Guides
- 2. Slider shoes
- 3. Equal distance

To correct, stop engine then loosen the lock nuts and tighten the adjustment screw on side where guides are farthest to runner. Tighten lock nuts and recheck alignment.

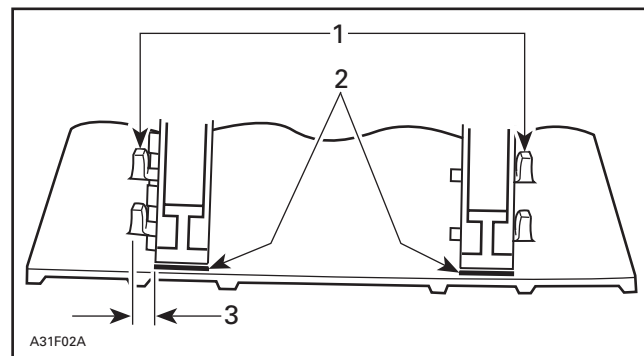

A31F02A

- 1. Guides
- 2. Slider shoes
- 3. Tighten on this side

Tighten lock nuts and the idler wheel retaining screws.

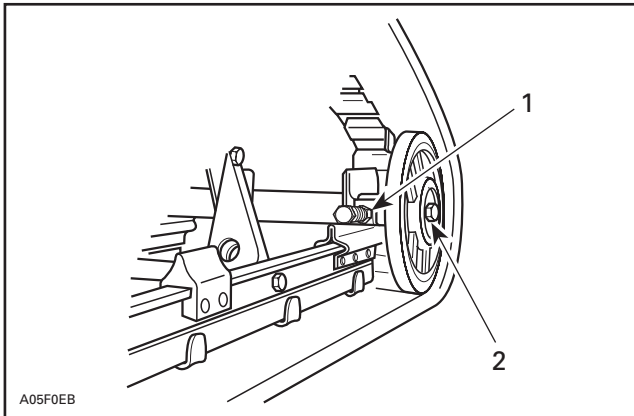

**TYPICAL**

1. Retighten lock nuts
2. Retighten rear idler wheel retaining screws

Restart engine, rotate track **slowly** and recheck alignment.

# TABLE OF CONTENTS

---

<b>STEERING SYSTEM</b> .....	<b>08-02-1</b>
INSPECTION .....	08-02-2
DISASSEMBLY AND ASSEMBLY .....	08-02-2
INSPECTION .....	08-02-2
STEERING ADJUSTMENT (skis) .....	08-02-3
LUBRICATION .....	08-02-5

---

<b>SUSPENSION AND SKI SYSTEM</b> .....	<b>08-03-1</b>
DISASSEMBLY .....	08-03-2
INSPECTION .....	08-03-2
INSTALLATION .....	08-03-2

# STEERING SYSTEM

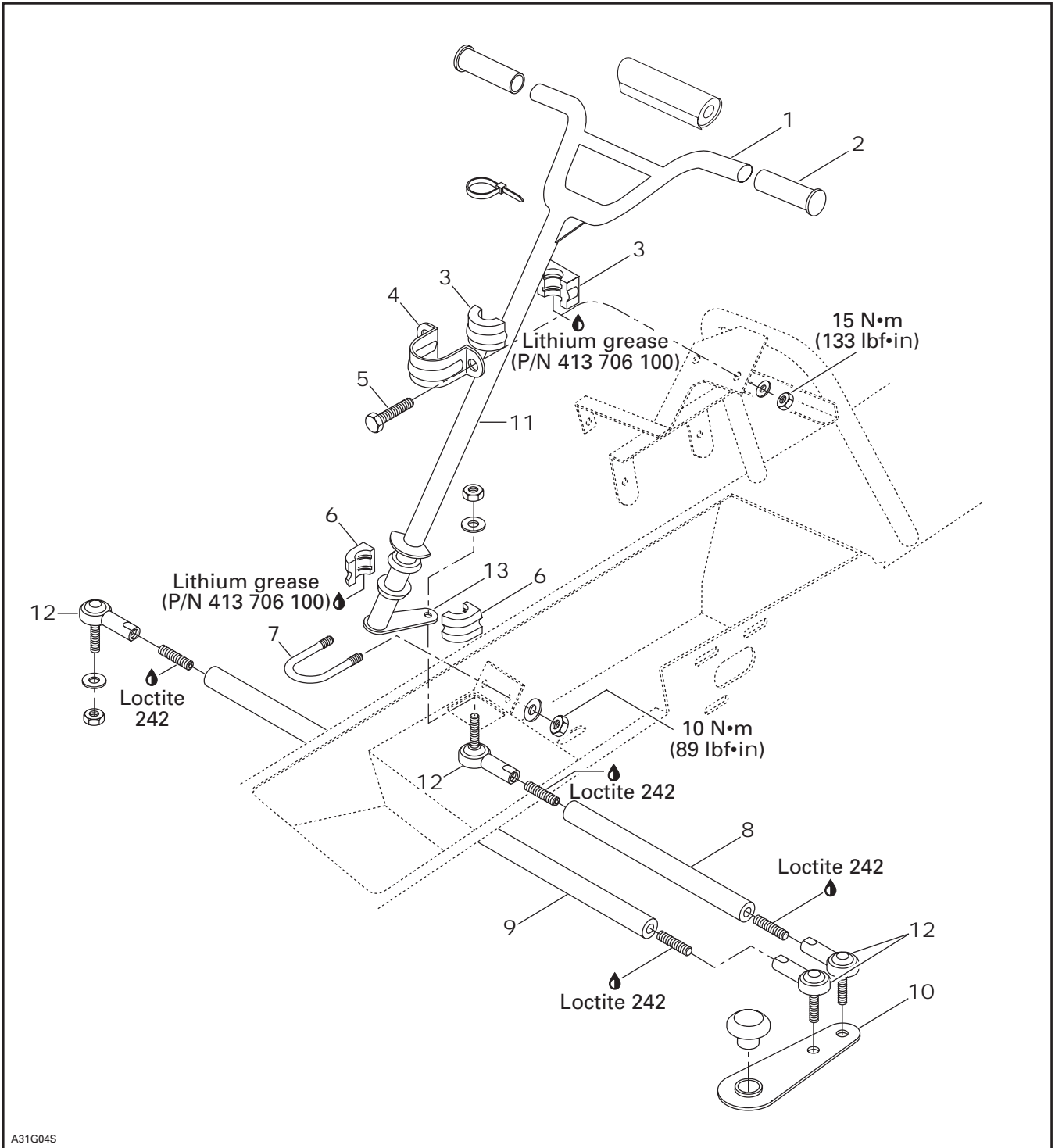

A31G04S

## Section 08 STEERING/FRONT SUSPENSION

### Subsection 02 (STEERING SYSTEM)

## INSPECTION

Check skis and runner shoes for wear, replace as necessary. Refer to SUSPENSION AND SKI SYSTEM 08-03.

## Steering System

Check general condition of steering system.  
Check general condition of steering system components for wear and replace if necessary.

## DISASSEMBLY AND ASSEMBLY

### 2, Grip

Grips can be removed and installed without any damage by injecting compressed air into the handlebar or by heating them with a heat gun.

### 11, Steering Column

From underneath bottom pan, remove tie rod clip. Refer to STEERING ADJUSTMENT (SKIS) for clip removal.

Detach short tie rod **no. 8** from steering column **no. 11**, as shown in the next photo.

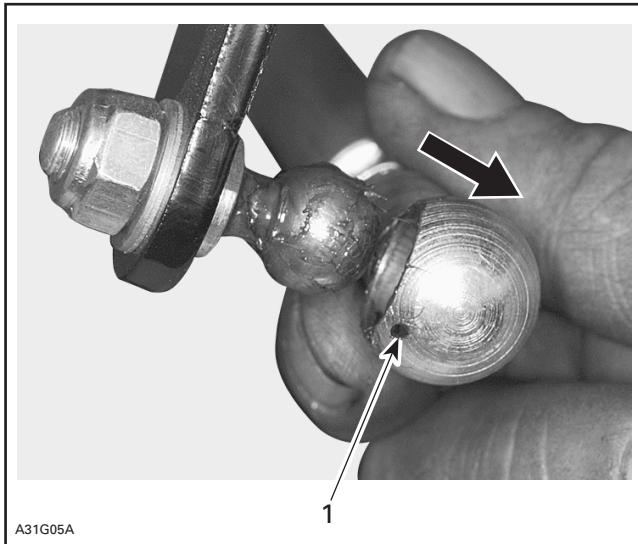

#### DETACH TIE ROD

1. Clip removed

Remove U-clamp **no. 7** with both half bushings, **no. 6** as shown in the following photo.

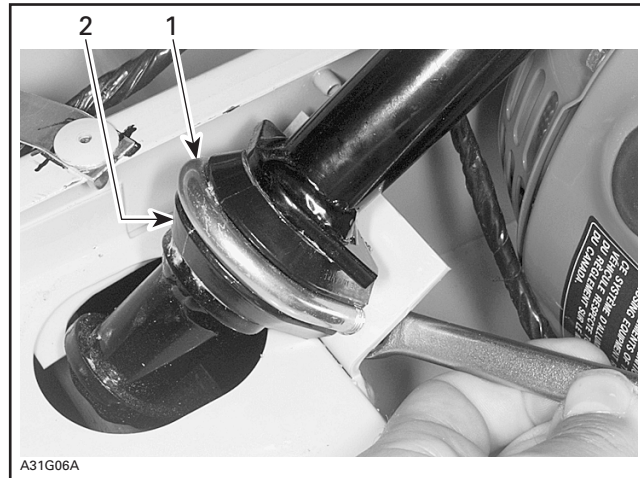

#### REMOVE U-CLAMP

1. U-clamp
2. Bushing

Remove retaining support **no. 4** with both half bushings **no. 3**, as shown in the following photo.

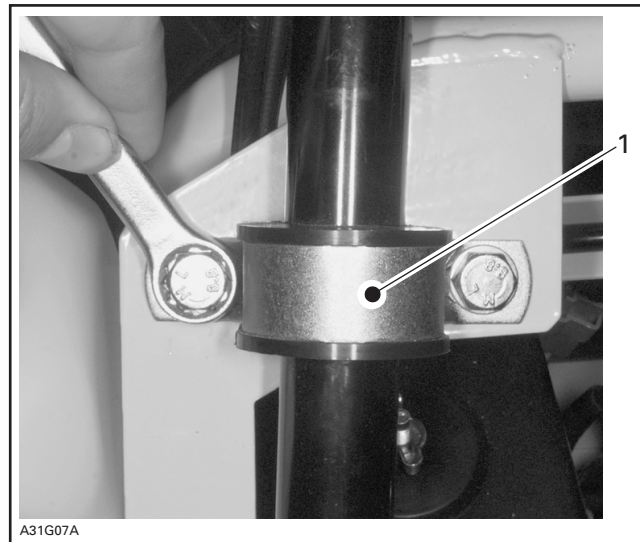

1. Retaining support

## INSPECTION

### 12, Ball Joint

Inspect ball joint ends for wear or looseness, if excessive, replace.

Screw threaded end of ball joint into tie rod. The maximum length for ball joint center to tie rod end must not exceed the value **L** in the following chart:

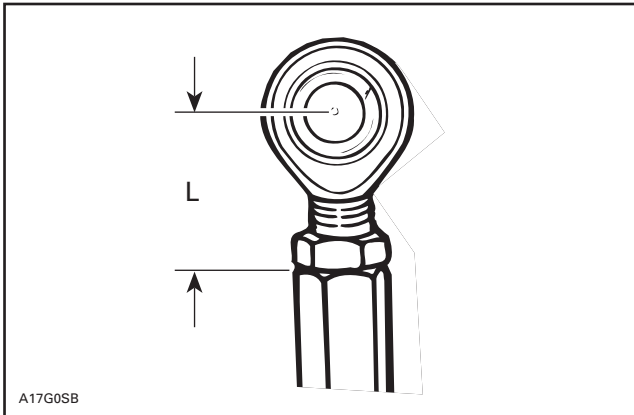

A17G0SB

TYPICAL

MODEL	L	
	mm	(in)
Mini Z	47	(1-27/32)

The cut-off section of the tie rod end must run parallel with the horizontal line of the steering arm when assembled on vehicle. The ball joint should be restrained when tightening tie rod end lock nut. For torque specifications see specific exploded view.

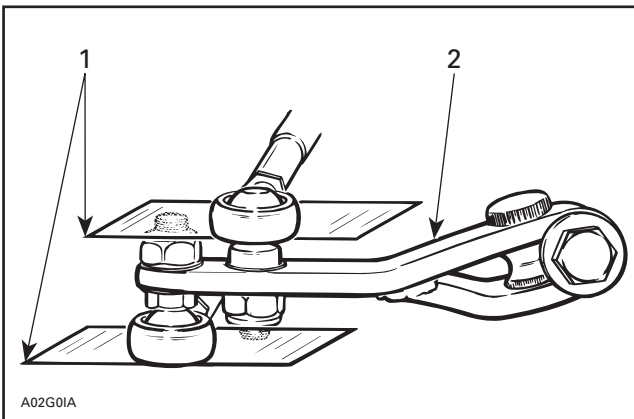

A02G01A

TYPICAL

1. Parallel with steering arm
2. Steering arm

## ◆ WARNING

The cut off section of the ball joint must run parallel with the steering arm. When tightening lock nuts, restrain ball joint with appropriate size wrench. Ensure not too many threads are kept outside of the tie rod according to the thread length chart.

## STEERING ADJUSTMENT (skis)

### Definitions

#### TOE-OUT:

Difference in measurement between front edge A and rear edge B of skis as viewed from top side of suspension system. It is adjustable.

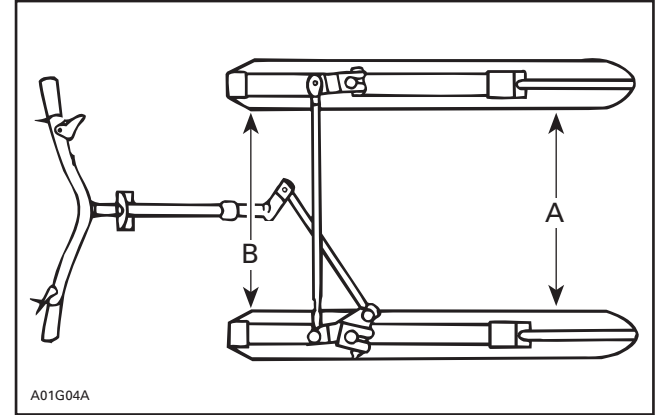

A01G04A

#### CAMBER:

A specific inward or outward tilt angle of ski leg compared to a vertical line when viewing vehicle from front. **This angle is not adjustable on Mini Z.**

### Adjustments

Adjustments should be performed following this sequence:

- Pivot arm centering/horizontal handlebar.
- Set toe-out.

#### PIVOT ARM CENTERING/HORIZONTAL HANDLEBAR

Turn handlebar no. 1 until pivot arm no. 13 is well centered.

Check if handlebar is horizontal and skis aligned with track. If not, adjust as per following procedure:

Loosen lock nut of short tie rod end.

Using a flat screwdriver, remove clip on short tie rod end, as shown in the next photo.



Section 08 STEERING/FRONT SUSPENSION  
 Subsection 02 (STEERING SYSTEM)



A31G08A

TO REMOVE CLIP — LIFT THEN PULL OUT

Detach short tie rod end from steering arm no. 10. Check that handlebar is horizontal and that skis are aligned with track.

Rotate tie rod end CW or CCW until proper alignment with steering arm is attain. See next photo.

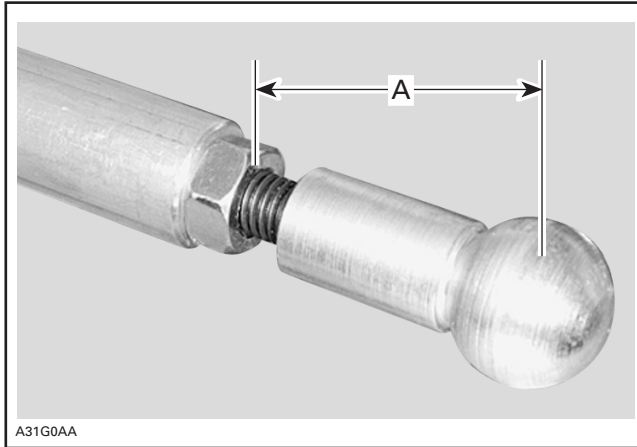

A31G0AA

A. 47 mm (1-27/32 in) maximum

Restrain tie rod while firmly retighten nuts so that ball joint sockets run parallel with steering arm and pivot arm.

**WARNING**

Ball joint sockets must run parallel with steering arm and pivot arm. Tie rod must be restrained when tightening lock nuts.

Ensure that pivot arm no. 13 is still centered and check ski toe-out.

**TOE-OUT**

Loosen lock nuts of long tie rod end no. 9 and detach tie rod end from steering arm no. 10.

Turn each tie rod end to adjust toe-out. See next photo.



A31G09A

DETACH TIE ROD END AND ROTATE CW OR CCW TO ADJUST

Re-attach tie rod end to steering arm.

**WARNING**

Maximum length for ball joint center to tie rod end must not exceed 47 mm (1-27/32 in). Torque lock nut to 15 N•m (133 lbf•in).

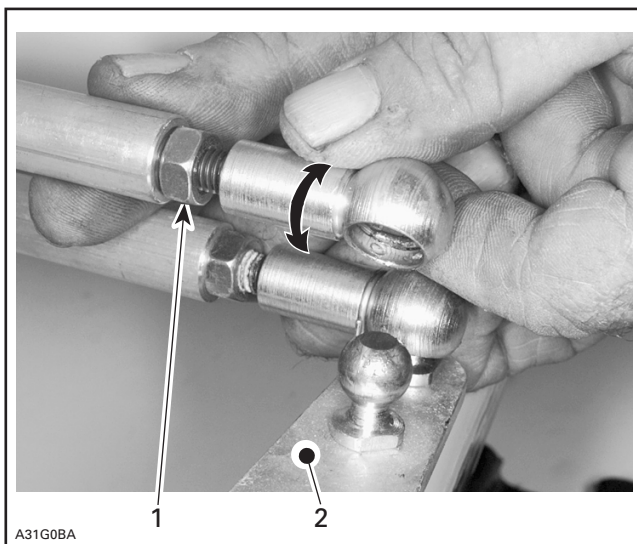

A31G0BA

TO ADJUST — ROTATE TIE ROD END

1. Loosen lock nut
2. Steering arm

Re-attach tie rod end to steering arm then secure with clip.

**NOTE:** To measure toe-out, place a straight edge against pre-adjusted track and measure distance between front and rear of skis and straight edge. Distances should be equal. After ski toe-out adjustment, distance at front of ski must be 3.0 mm (1/8 in) more than at rear on both sides for a total toe-out of 6 mm (1/4 in).

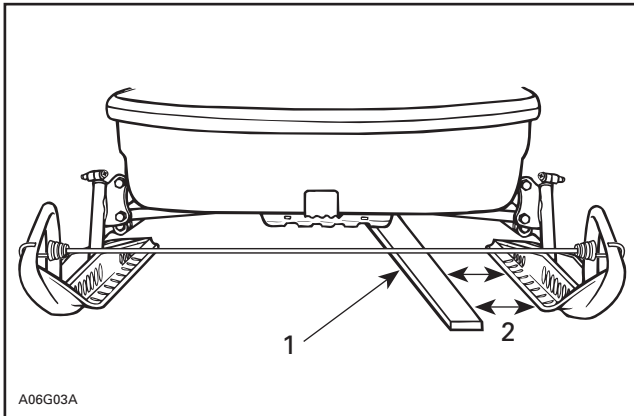

**TYPICAL**

1. Straight edge
2. 3.0 mm (1/8 in) more at front than at rear

Check external threaded length not engaged and firmly retighten lock nuts, as shown in the next photo.



**HOLD TIE ROD THEN TIGHTEN LOCK NUT**

## LUBRICATION

### ◆ WARNING

Do not lubricate throttle and/or brake cable, housing and spring coupler bolts.

## Steering Column

Use lithium grease (P/N 413 706 100) at U-clamp and retaining support location on steering column.

## Ball Joints

Lightly grease ball joints with bearing grease (P/N 413 706 100).

# SUSPENSION AND SKI SYSTEM

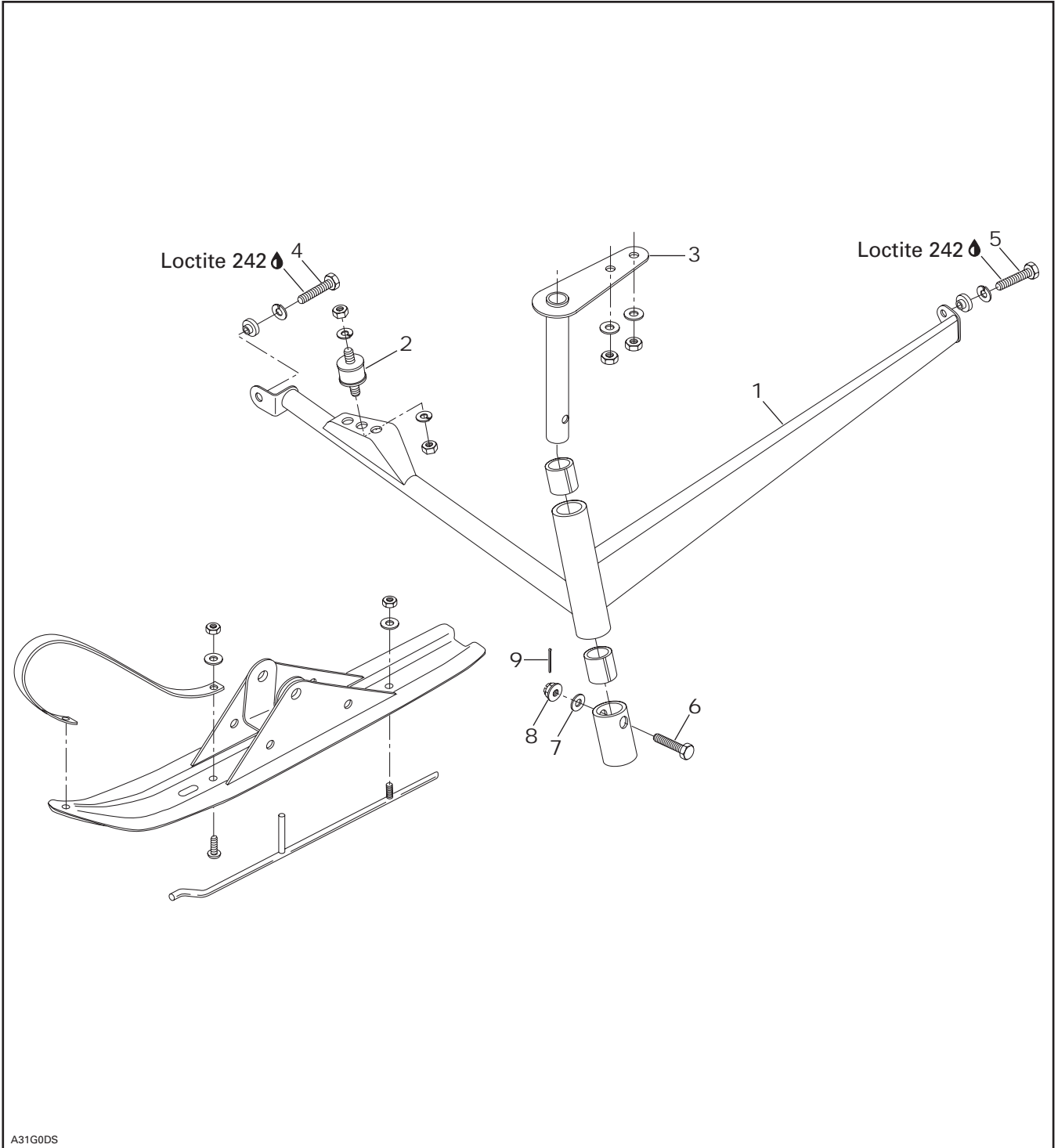

Section 08 STEERING/FRONT SUSPENSION  
Subsection 03 (SUSPENSION AND SKI SYSTEM)

## DISASSEMBLY

### 2, Rubber Mount

Lift front of vehicle and support it off the ground.  
Note rubber mount position.

Remove lower nut then upper nut of rubber mount.

### 1, Swing Arm

Lift front of vehicle and support it off the ground.  
Unbolt ski.

Unbolt lower end of rubber mount from swing arm **no. 1**.

Remove nuts and washers then detach tie rod end from steering arm **no. 3**.

Remove swing arm front screw **no. 4** from frame.

Remove swing arm rear screw **no. 5** from frame.

Pull swing arm off the vehicle.

## INSPECTION

Check both rubber mounts for loose and wear. If so, replace with new one.

Check all rubber cushions for crack and wear. Replace as required.

Check for straightness of swing arm. Replace as required.

Check skis and runners for wear, replace as necessary.

## INSTALLATION

For assembly, reverse the disassembly procedure. However, pay attention to the following.

Tighten nuts and screws to proper torque and apply Loctite 242 where specified, as mentioned in exploded view.

## Ski

Slide ski on ski leg as shown in the next photo.



### SLIDE SKI

1. Ski leg spacer

Secure ski with screw **no. 6**, washer **no. 7**, nut **no. 8** and cotter pin **no. 9**, then ensure that ski pin is properly centered into ski leg, as shown in the following photo.

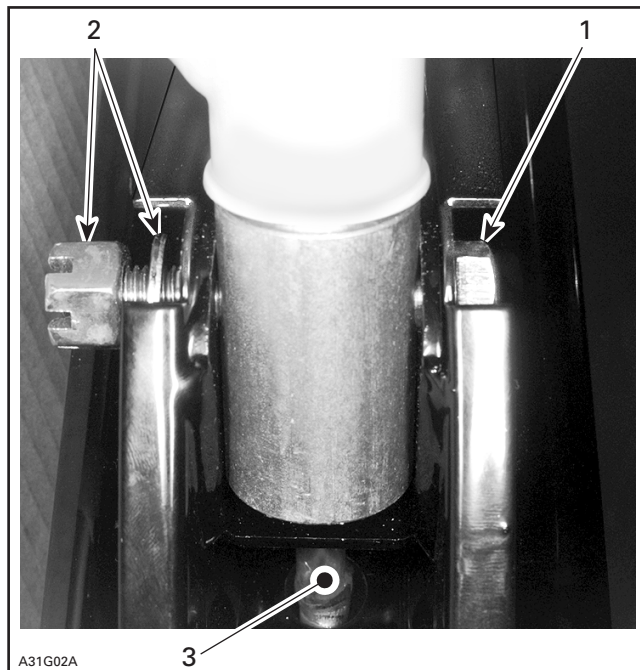

1. Bolt head toward *OUTSIDE* of vehicle

2. Washer, nut and cotter pin (not shown) toward *inside* of vehicle

3. Ski pin centered into ski leg

 **WARNING**

Always use new cotter pin when reinstalling skis.

### Tie Rod

Position tie rods horizontally before tightening nuts.

# TABLE OF CONTENTS

---

<b>BODY</b> .....	<b>09-02-1</b>
<b>INSTALLATION AND ADJUSTMENT</b> .....	<b>09-02-2</b>
HEADLAMP BEAM AIMING .....	09-02-2
BULB REPLACEMENT .....	09-02-2
DECAL .....	09-02-3
WINDSHIELD INSTALLATION.....	09-02-3
CHAIN GUARD .....	09-02-4
WIRING HARNESS .....	09-02-4
CABLES .....	09-02-4
PIPING .....	09-02-4
<b>PLASTIC REPAIR</b> .....	<b>09-02-5</b>
REPAIR.....	09-02-5
<hr/>	
<b>FRAME</b> .....	<b>09-03-1</b>
FRAME CLEANING .....	09-03-2
FRAME WELDING .....	09-03-2
FRAME COMPONENT REPLACEMENT .....	09-03-2

# BODY

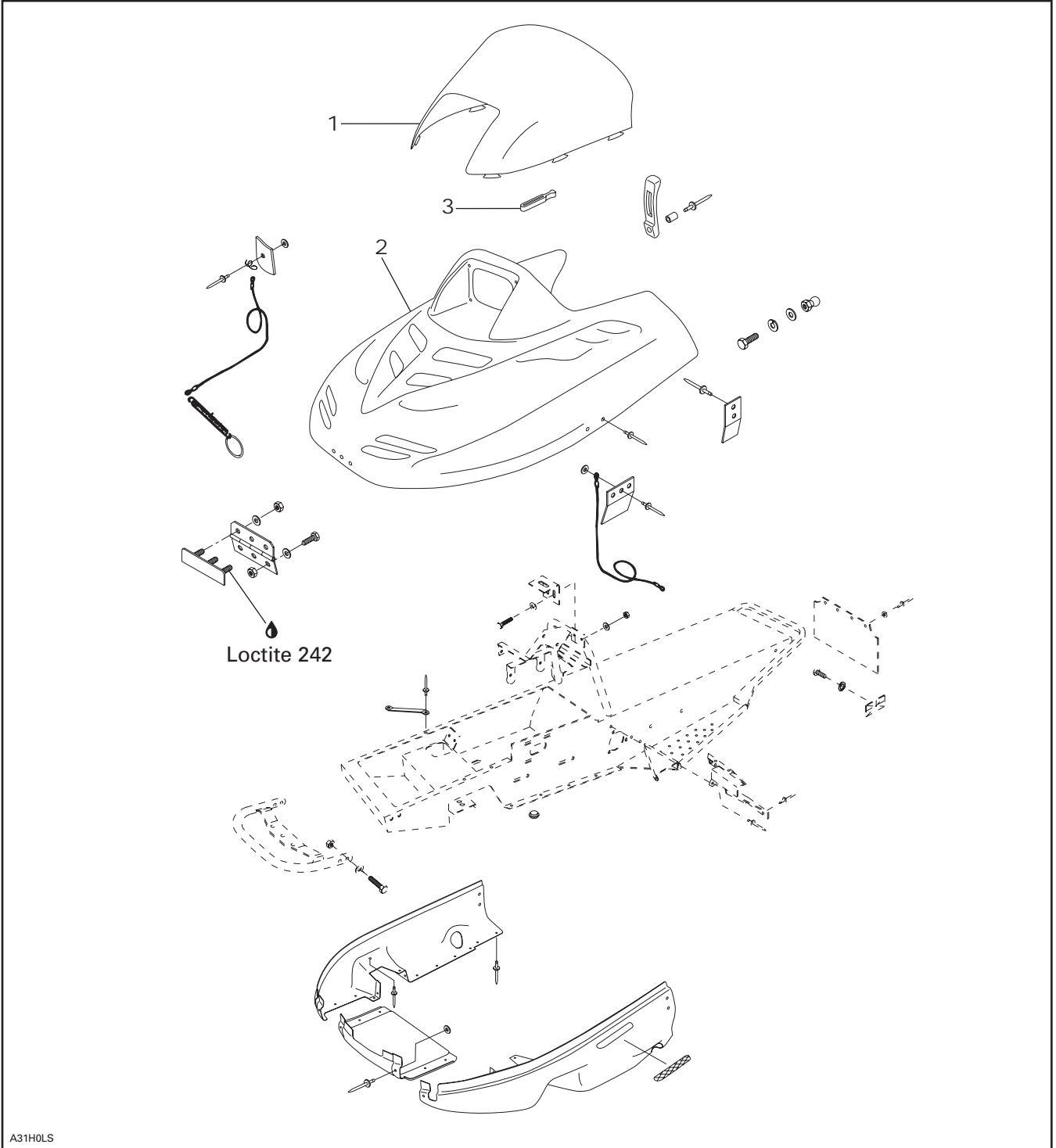

A31H0LS

## INSTALLATION AND ADJUSTMENT

### HEADLAMP BEAM AIMING

Beam aiming is correct when center of high beam is 25 mm (1 in) below the headlamp horizontal center line, scribed on a test surface, 381 cm (12 ft 6 in) away.

Measure headlamp center distance from ground. Scribe a line at this height on test surface (wall or screen). Light beam center should be 25 mm (1 in) below scribed line.

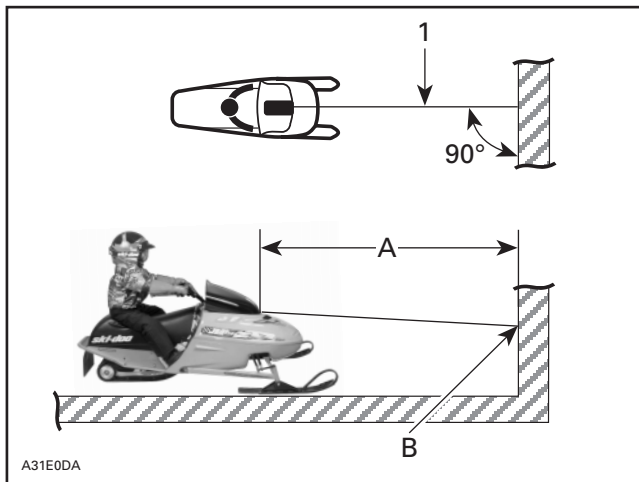

1. Headlamp center line
- A. 381 cm (12 ft 6 in)
- B. 25 mm (1 in) below headlamp center

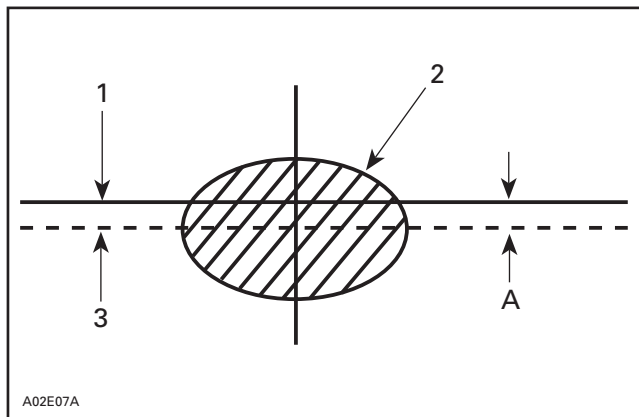

1. Headlamp horizontal center line
2. Light beam (high beam) (projected on the wall)
3. Light beam center
- A. 25 mm (1 in)

### Required Conditions

Place the vehicle on a flat surface perpendicular to test surface (wall or screen) and 381 cm (12 ft 6 in) away from it.

Rider or equivalent weight must be on the vehicle.

### Adjustment

Remove headlamp screw caps. Turn screws accordingly at upper headlamp attachment.

### BULB REPLACEMENT

#### Headlight

If headlamp bulb is burnt, tilt hood.

Remove the rubber boot and turn the bulb retainer ring counterclockwise.

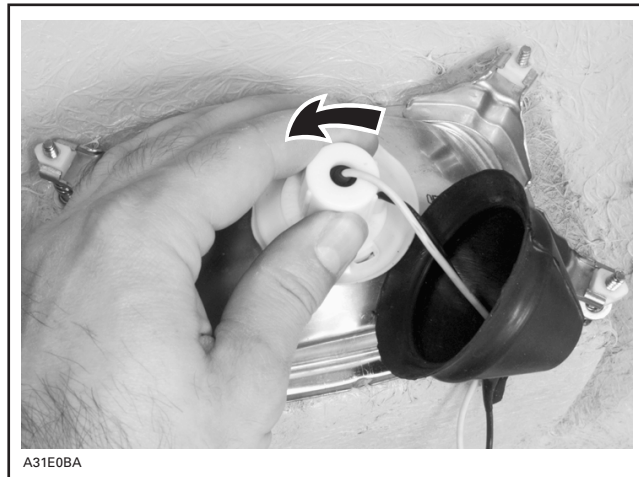

#### REMOVE RUBBER BOOT AND BULB RETAINER RING

Pull off bulb retainer ring, detach the bulb and replace. Properly reinstall parts.





## Taillight

Taillight is sealed, if it is burnt, replace taillight ass'y with new one.

To remove, unscrew the 2 lens screws.

Pull out taillight ass'y.

Unplug connector.

Install new taillight ass'y.

## DECAL

To remove a decal; heat old decal with a heat gun and peel off slowly.

Using isopropyl alcohol, clean the surface and dry thoroughly.

Apply liquid soap to new decal and carefully position the decal. Using a sponge or a squeegee, remove the air bubbles and surplus water working from the center toward the edges. Allow to air dry.

### ▼ CAUTION

Do not apply isopropyl alcohol or solvent directly on decals.

## WINDSHIELD INSTALLATION

When peeling off the protective film some polyethylene particles may remain on the windshield **no. 1**. A soft clean cloth moistened with naphtha (camping equipment fuel) will easily remove the remaining particles.

### ◆ WARNING

Naphtha is flammable and explosive under certain conditions. Always manipulate in a well ventilated area. Do not smoke or allow open flames or sparks in the vicinity.

Position the windshield **no. 1** on the hood **no. 2** then push it down until the tabs are fully inserted into the hood slots, as shown.

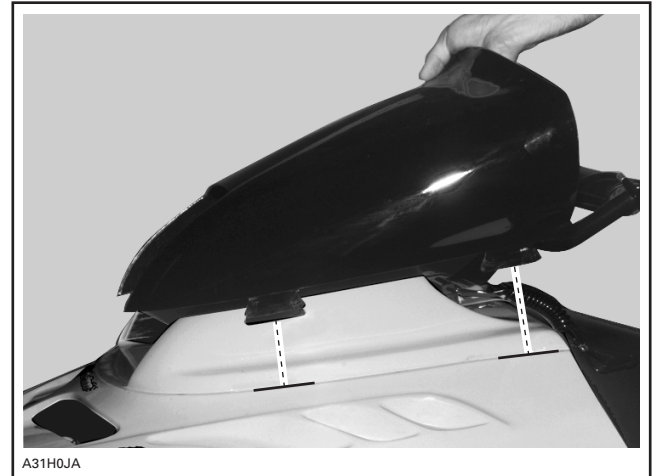

INSERT WINDSHIELD TABS INTO HOOD SLOTS

From inside hood, lock the windshield tabs in position using latches **no. 3** as shown.

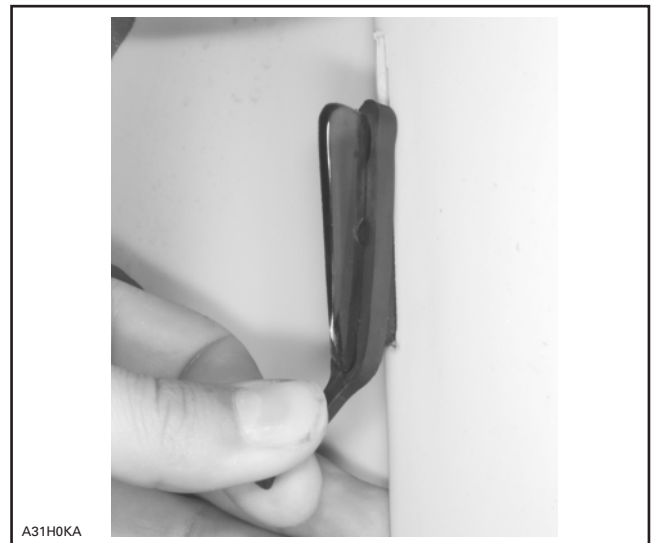

VIEW FROM INSIDE HOOD — LOCK WINDSHIELD TABS

## CHAIN GUARD

### Disassembly and Assembly

 **WARNING**

Engine should be running only with chain guard well secured in place.

### Inspection

Check chain guard mounting tabs and spring nuts for wear.

## WIRING HARNESS

 **WARNING**

Ensure all terminals are properly crimped on the wires and that all connector housings are properly fastened. Keep wires away from any rotating, moving, heating and vibrating parts. Use proper fastening devices as required.

## CABLES

 **WARNING**

Before installation, ensure that all cables are in perfect condition. Properly install the cable ends and secure them in place. Pay attention to route them properly, away from any rotating, moving, heating, or vibrating parts.

## PIPING

 **WARNING**

Always ensure that the fuel and vent, lines are properly fixed to their connectors, that they are not perforated or kinked and that they are properly routed away from any rotating, moving, heating or vibrating parts. Also check for leaks. Replace if required.

**NOTE:** Refer to proper *Parts Catalog* to find suitable clip part numbers.

## PLASTIC REPAIR

### REPAIR

Two types of plastic material are used on Mini Z model, as described in the following table.

	MATERIAL
WINDSHIELD	Polycarbonate
HOOD	Polyethylene
BOTTOM PAN	Polyethylene

Both plastic materials are irreparable.

In the case that parts are broken or damaged, replace with new one.

 **WARNING**

Polycarbonate windshields must never be repaired by welding or otherwise.

# FRAME

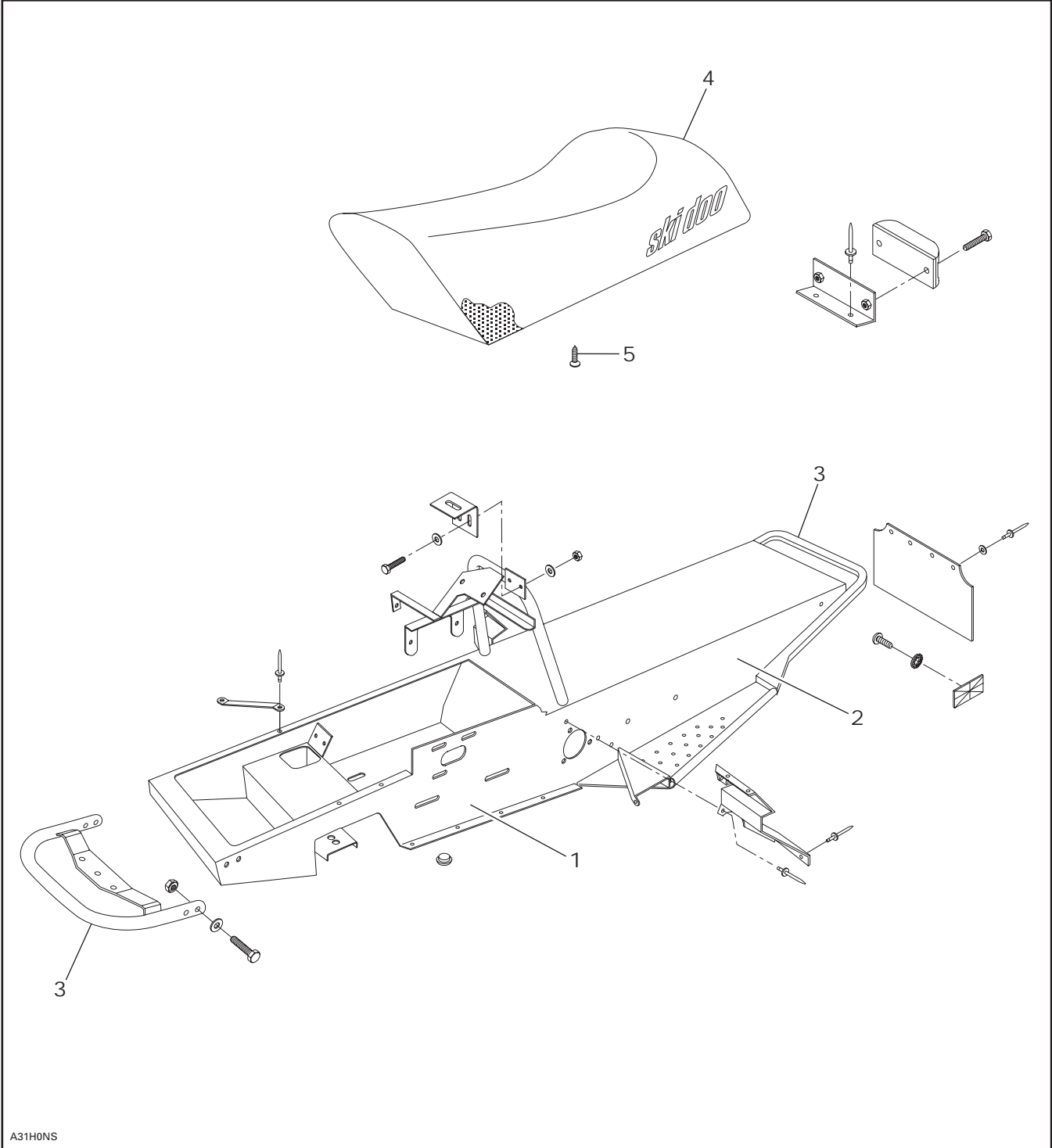

A31H0NS

## FRAME CLEANING

Clean frame **no. 1**, tunnel **no. 2** and bumpers **no. 3** with appropriate cleaners and rinse with high pressure hose.

Touch up all metal spots where paint has been scratched off. Spray all bare metal parts of vehicle with metal protector.

## Seat Removal/Replacement

Seat **no. 4** is retained to tunnel with 4 wood screws **no. 5**. All screws must be removed from inside tunnel.

To remove both front wood screws **no. 5**, detach rear suspension from tunnel, as described in section 07 REAR SUSPENSION.

### ▼ CAUTION

Ensure that 4 wood screws **no. 5** have been removed before removing seat.

## Seat Cleaning

It is recommend to clean the seat **no. 4** with a solution of **warm soapy water**, using a soft clean cloth.

### ▼ CAUTION

Avoid use of harsh detergents such as strong soaps, degreasing solvents, abrasive cleaners, paint thinners, etc. that may cause damage to the seat cover.

## FRAME WELDING

### Steel Frame:

- electric welding
- amperage: 70-110 A
- voltage: 20-24 V
- rod: E-7014 (3/32 in)

### ▼ CAUTION

If welding is to be done near plastic material, it is recommended to either remove the part from the area or to protect it with aluminum foil to prevent damage.

## FRAME COMPONENT REPLACEMENT

### Drilling Procedure

For proper drilling instructions and to prevent premature wear, follow the procedure below.

Always use a variable speed electric drill.

Center the drill bit on the rivet hole and drill.

Maintain a slow to medium speed at all times when drilling. The proper speed is attained when a constant breaking chip is ejected.

**NOTE:** To increase bit life, use Bombardier synthetic chaincase oil (P/N 413 803 300) as a cutting oil.

### ▼ CAUTION

High speed drilling will cause excessive heat which may destroy the cutting edge of the bit, therefore avoid using pneumatic drills.

# TECHNICAL DATA

## SI\* METRIC INFORMATION GUIDE





BASE UNITS			
DESCRIPTION	UNIT	SYMBOL	
length .....	meter .....	m	
mass .....	kilogram .....	kg	
force .....	newton .....	N	
liquid .....	liter .....	L	
temperature .....	Celsius .....	°C	
pressure .....	kilopascal .....	kPa	
torque .....	newton•meter .....	N•m	
speed .....	kilometer per hour .....	km/h	
PREFIXES			
PREFIX	SYMBOL	MEANING	VALUE
kilo .....	k .....	one thousand .....	1 000
centi .....	c .....	one hundredth .....	0.01
milli .....	m .....	one thousandth .....	0.001
micro .....	μ .....	one millionth .....	0.000001
CONVERSION FACTORS			
TO CONVERT	TO †	MULTIPLY BY	
in .....	mm .....	25.4	
in .....	cm .....	2.54	
in <sup>2</sup> .....	cm <sup>2</sup> .....	6.45	
in <sup>3</sup> .....	cm <sup>3</sup> .....	16.39	
ft .....	m .....	0.3	
oz .....	g .....	28.35	
lb .....	kg .....	0.45	
lbf .....	N .....	4.4	
lbf•in .....	N•m .....	0.11	
lbf•ft .....	N•m .....	1.36	
lbf•ft .....	lbf•in .....	12	
PSI (lbf/in <sup>2</sup> ) .....	kPa .....	6.89	
imp. oz .....	U.S. oz .....	0.96	
imp. oz .....	mL .....	28.41	
imp. gal .....	U.S. gal .....	1.2	
imp. gal .....	L .....	4.55	
U.S. oz .....	mL .....	29.57	
U.S. gal .....	L .....	3.79	
MPH .....	km/h .....	1.61	
Fahrenheit .....	Celsius .....	(°F – 32) ÷ 1.8	
Celsius .....	Fahrenheit .....	(°C × 1.8) + 32	

\* The international system of units abbreviates SI in all languages.





† To obtain the inverse sequence, divide by the given factor. To convert "mm" to "in", divide by 25.4.

NOTE: Conversion factors are rounded off to 2 decimals for easier use.

Section 10 TECHNICAL DATA  
Subsection 02 (ENGINES)

VEHICLE MODEL		MINI Z			
ENGINE TYPE		4 stroke Overhead valves			
	Number of Cylinders	1			
	Bore	mm (in)	60.00 (2.362)		
	Stroke	mm (in)	42.00 (1.654)		
	Displacement	cm <sup>3</sup> (in <sup>3</sup> )	118.00 (7.20)		
	Compression Ratio (corrected)	8.5 : 1			
	Maximum Power Engine Speed	± 100 RPM	4000		
	Ring End Gap	Top/Second Oil (wear limit)	mm (in)	0.2 - 0.4 (.008 - .016) 0.15 - 0.35 (.006 - .014) 1.0 (.04)	
	Ring/Piston Groove Clearance	(standard) (wear limit)	mm (in) mm (in)	.015 - .045 (.0006 - .0018) .15 (.006)	
	Piston/Cylinder Wall Clearance	(standard) (wear limit)	mm (in) mm (in)	.015 - .05 (.0006 - .002) .12 (.005)	
	Connecting Rod Big End Side Clearance	(standard) (wear limit)	mm (in) mm (in)	0.1 - 0.7 (.004 - .028) 1.1 (.043)	
	Ignition Type	Transistorized			
	Spark Plug Make and Type	NGK BPR6 ES			
	Spark Plug Gap	mm (in)	0.7 - 0.8 (.028 - .031)		
	Ignition Timing BTDC	mm (in)	25° (fixed)		
	Lamp Coil Ⓞ	0.18 - 0.23			
	Ignition Coil Ⓞ	Primary	Ω	0.8 - 1.0	
Secondary		Ω	5.9 - 7.1		
	Carburetor Type	Horizontal Butterfly Valve			
	Main Jet	# 60			
	Float Height Adjustment	± 1 mm (± .040 in)	13.7 (.54)		
	Pilot Screw Opening	± 1/16 turn	2 turns out		
	Idle Speed RPM	± 200 RPM	1400		
	Gas Type/Pump Octane Number	Unleaded/86			
	Oil	SAE 5W/30			
	Type	Radial Fan			
	ENGINE COLD N <sub>m</sub> (lb•ft)	Drive Sprocket Retaining Screw	25 (19)		
		Exhaust Nuts	24 (18)		
		Crankcase Screws	M6	12 (9)	
		Cylinder Head Screws	24 (18)		
		Axial Fan/Flywheel Nut	75 (55)		

Section 10 TECHNICAL DATA  
Subsection 03 (VEHICLES)

	<b>VEHICLE MODEL</b>	<b>MINI Z</b>		
	<b>ENGINE TYPE</b>	<b>4 stroke Overhead valve</b>		
	Drive Chain Ratio	10/48		
	Drive Chain	Pitch mm (in)	12.7 (.500)	
		Type/Links Qty	Single 40/78	
	Drive Sprocket	Clutch Engagement	N.A.	
	Driven Sprocket	Outside diameter mm (in)	201.37 (7.93)	
		Pitch diameter mm (in)	194.18 (7.65)	
	Drive Chain Part Number (P/N)		412 1075 00	
	Drive Chain Adjustment		Deflection	
			Automatic tensioner	
	Track	Width	mm (in)	254.0 (10)
			mm (in)	1748.8 (68.85)
			mm (in)	15.97 (.63)
Adjustment		Deflection mm (in)	35 (1-3/8)	
		Force ① kg (lbf)	7.3 (16)	
Suspension Type		Track	Mini Z	
		Ski	Mini Z	
	Length	mm (in)	1860.0 (73.2)	
	Width	mm (in)	885.0 (34.8)	
	Height	mm (in)	750.0 (29.5)	
	Ski Stance	mm (in)	685.0 (27.0)	
	Mass (dry)	kg (lb)	70 (154)	
	Ground Contact Area	cm <sup>2</sup> (in <sup>2</sup> )	2754.5 (426.9)	
	Ground Contact Pressure	kPa (PSI)	2.49 (.361)	
	Frame Material		Steel	
	Bottom Pan Material		Polyethylene	
Hood Material		Polyethylene		
	Battery	V (A•h)	N.A.	
	Headlight	W	35	
	Taillight	W	4.5	
	Fuel Tank	L (U.S. gal)	1.8 (.5)	
	Oil Capacity	L (U.S. oz)	0.6 (20.3)	



## ENGINE TECHNICAL DATA LEGEND

BTDC: Before Top Dead Center

K: Kilo (x 1000)

MAG: Magneto Side

N.A.: Not Applicable

PTO: Power Take Off Side

R: Rectangular

ST: Semi-trapez

① All resistance measurements must be performed with parts at room temperature (approx. 20°C (68°F)). Temperature greatly affects resistance measurements.

## VEHICLE TECHNICAL DATA LEGEND

N.A.: Not Applicable

① Force or downward pull applied to track to obtain specified tension deflection.

# WIRING DIAGRAM

## WIRING DIAGRAM LEGEND

**◆ WARNING**

Ensure all terminals are properly crimped on the wires and all connector housings are properly fastened.

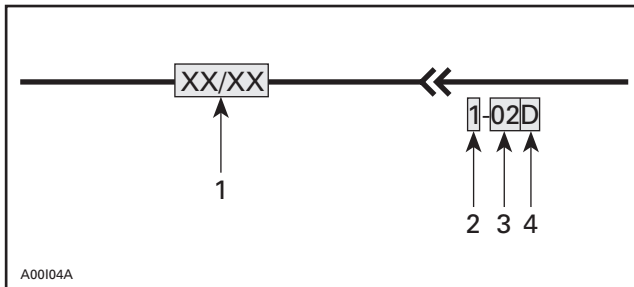

1. Wire colors
2. Housing area
3. Housing number per area
4. Wire connector location in housing

## WIRE COLORS AND CIRCUIT

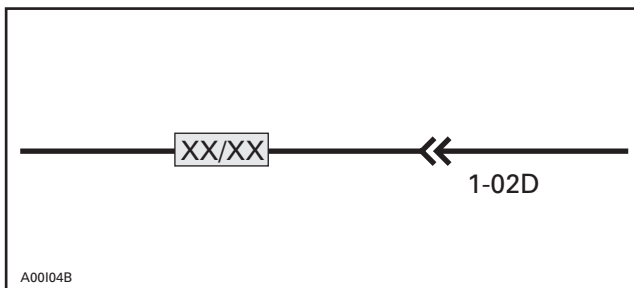

The first color of a wire is the main color, second color is the stripe.

Example: YL/BK is a YELLOW wire with a BLACK stripe.

COLOR CODE	
BK - BLACK	GY - GREY
WH - WHITE	VI - VIOLET
RD - RED	OR - ORANGE
BL - BLUE	BR - BROWN
YL - YELLOW	PK - PINK
GN - GREEN	

## CONNECTOR HOUSING AREA

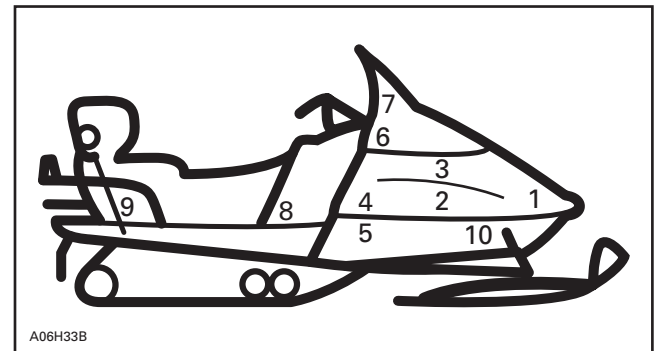
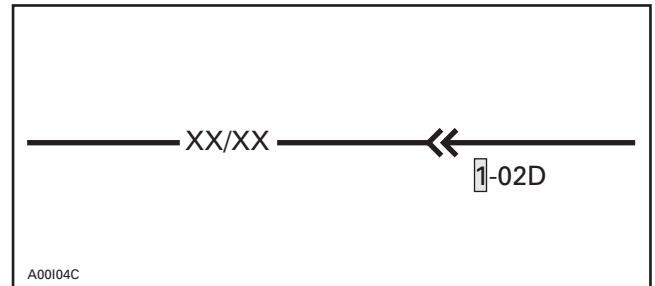





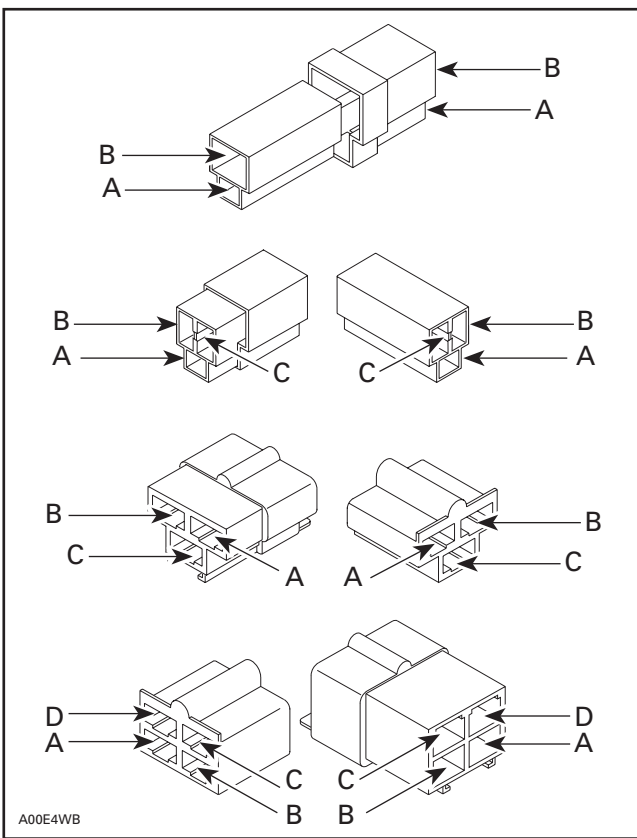
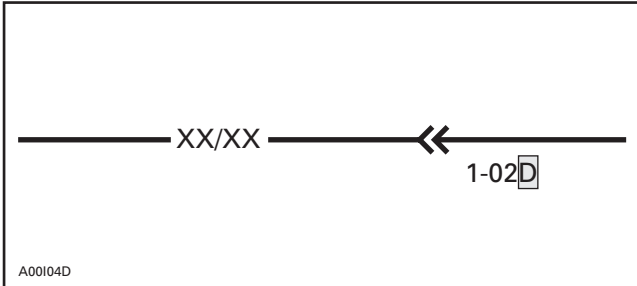



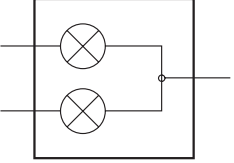

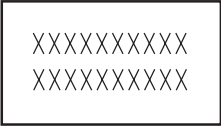
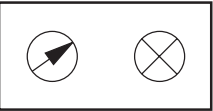
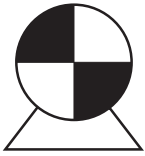
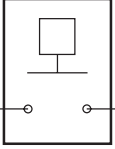
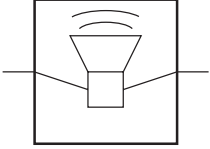
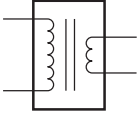
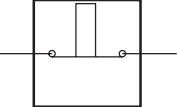
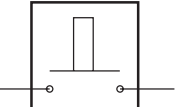

AREA	LOCATION
1	Front of engine compartment
2	Magneto
3	Carburetors
4	Near intake silencer
5	Near driven pulley
6	Under console
7	Under hood
8	Near fuel tank
9	Rear of seat
10	Under engine

## CONNECTOR LOCATION IN HOUSING

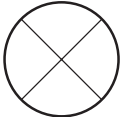
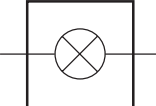
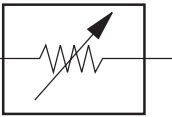
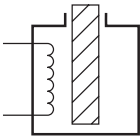

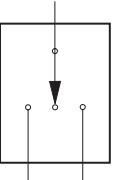
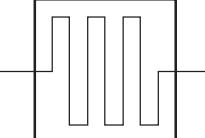
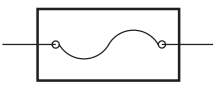
## SYMBOLS DESCRIPTION

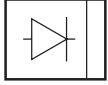
<p>Beam and tail light</p> 	<p>Female terminal</p> 	<p>Male terminal</p> 	<p>Electronic module</p> 
<p>Meter</p> 	<p>Electric motor</p> 	<p>Low level sensor</p> 	<p>Buzzer</p> 
<p>Ignition coil</p> 	<p>Normally close switch</p> 	<p>Normally open switch</p> 	<p>Male terminal on instrument</p> 
<p>Engine ground</p> 	<p>Frame ground</p> 	<p>Spark plug</p> 	<p>Meter movement</p> 
<p>Bulb</p> 	<p>Pilot lamp</p> 	<p>Analog sensor</p> 	<p>Solenoid valve</p> 
<p>Magneto</p> 	<p>3 position switch</p> 	<p>Heating element</p> 	<p>Fuse</p> 
<p>Trigger coil</p> 	<p>Battery</p> 		<p>Diode</p> 

# ANNEX 1      MINI Z

# MINI Z

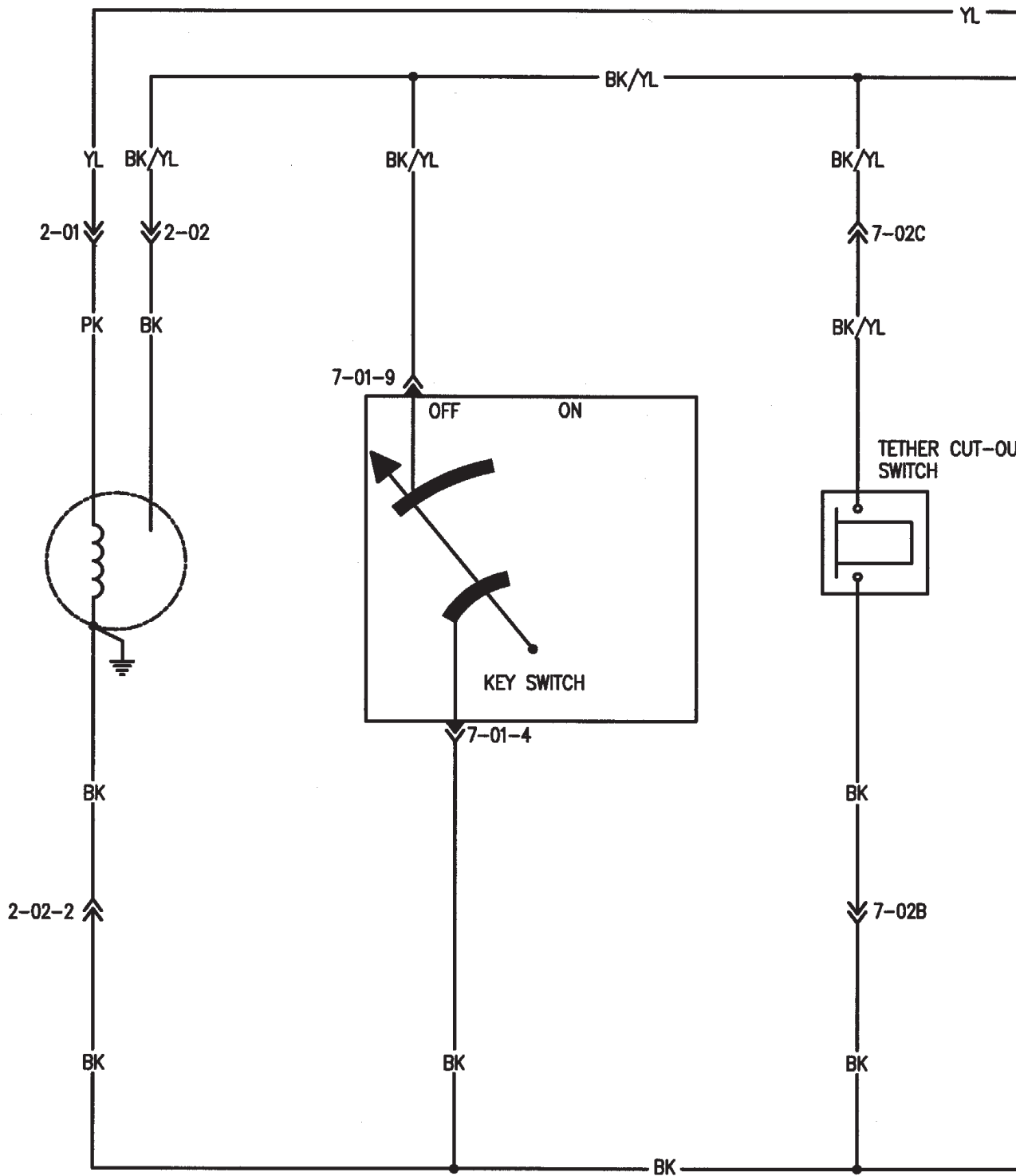

POWER SUPPLY SYSTEM

IGNITION SWITCHES

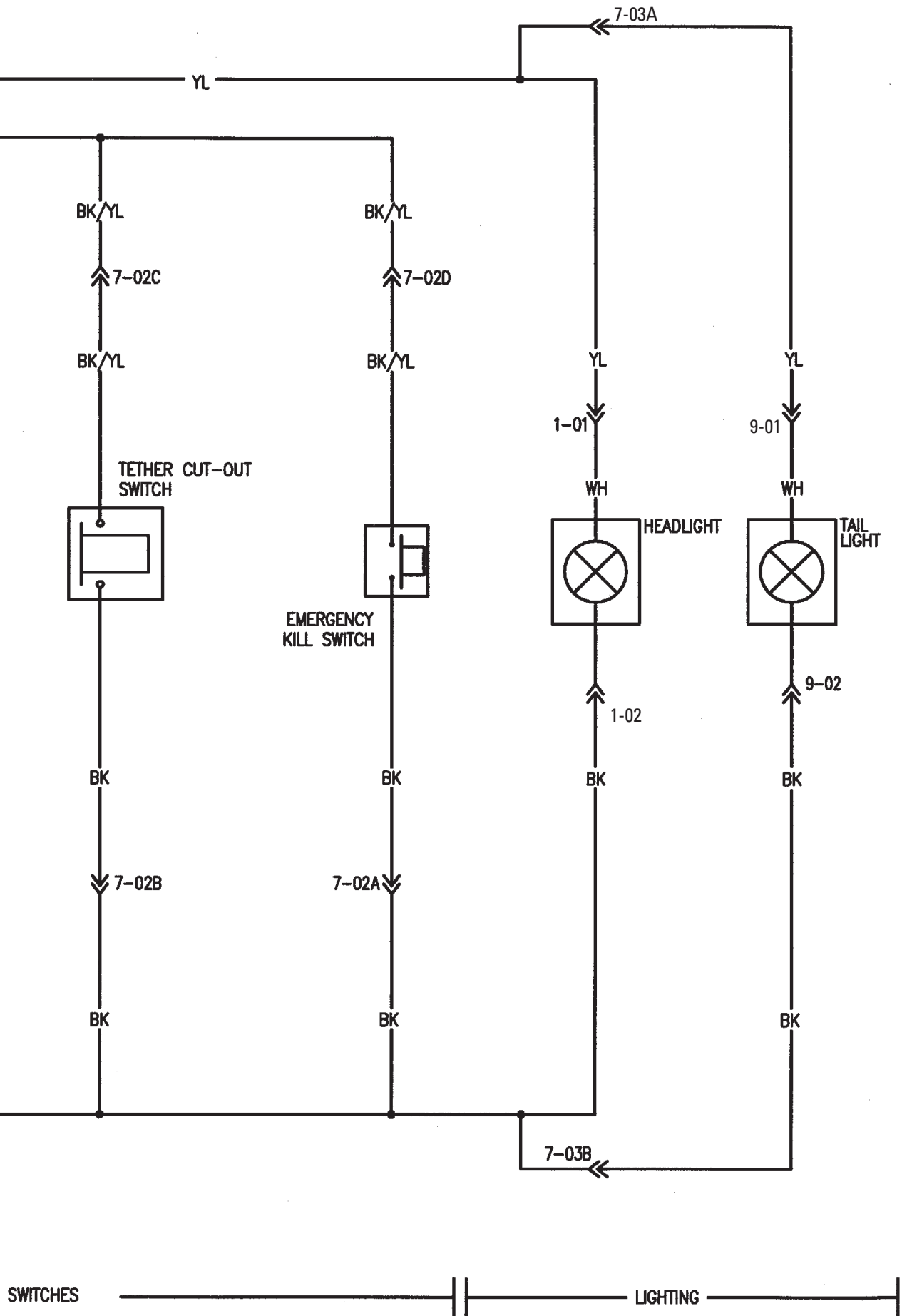



**BOMBARDIER**  
*RECREATIONAL PRODUCTS*



®\*Trademarks of Bombardier Inc.  
© 1998 Bombardier Inc. All Rights Reserved  
Litho'd in Canada

*VERSION FRANÇAISE ÉGALEMENT DISPONIBLE*