



 **WARNING**

For safety reasons, this kit must be installed by an authorized Bombardier snowmobile dealer. Should removal of a locking device be required when undergoing disassembly/assembly, always replace with a new one. This instruction sheet should be given to the purchaser. This kit is designed for specific models. It is not recommended for vehicles other than those for which it was sold.

 **CAUTION**

The following modifications and adjustments apply only for altitudes above 600 m (2000 ft).

NOTE: Installation time is approximately 1.5 hours.

## MODIFICATIONS AND ADJUSTMENTS

The transmission and carburation charts list all parts as well as modifications and adjustments needed for altitude and/or temperature changes.

*High Altitude Technical Data* sheets (P/N 484 300 003) containing technical information pertaining to carburetor jetting, transmission calibration, conversion charts and more, are available. They cover all models for the last 5 years. A convenient binder (P/N 484 054 500) can be ordered to organize the set.

## CARBURETOR JETTING

Stock vehicle jetting and the main jets included in this kit are prescribed for a temperature of - 20°C (- 4°F), as indicated by **bold face type** on the main jet chart. Snowmobile utilization above or below this temperature requires a different jetting. In that case, find the required main jet size in "Carburation" chart and order it according to the Bombardier P/N (part numbers) given in "Main Jet" P/N chart that can be found in the previously mentioned *High Altitude Technical Data* sheets.

# PARTS TO BE INSTALLED

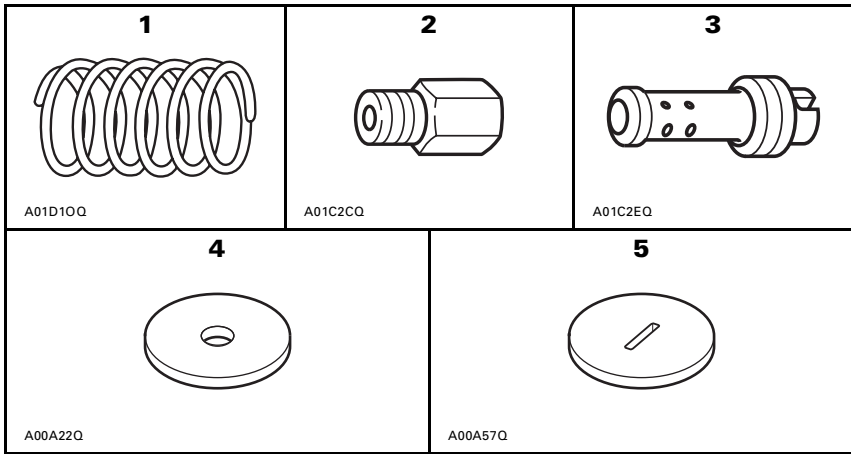

- |    |             |           |              |     |
|----|-------------|-----------|--------------|-----|
| 1. | 417 118 500 | Spring    | Yellow/Green | (1) |
| 2. | 404 119 500 | Main jet  | 185          | (1) |
|    | 404 119 200 | Main jet  | 175          | (1) |
|    | 404 120 900 | Main jet  | 150          | (1) |
|    | 404 126 600 | Main jet  | 140          | (1) |
|    | 404 124 900 | Main jet  | 130          | (1) |
| 3. | 404 102 700 | Pilot jet | 35           | (1) |
| 4. | 417 114 400 | Weight    |              | (6) |
| 5. | 417 114 500 | Capsule   |              | (3) |

# 1999-TUNDRA/TUNDRA R

## HIGH ALTITUDE KIT (P/N 861 768 900)

### DRIVE PULLEY (Tundra/Tundra R)

Altitude Clutching		Sea Level	600 m 2000 ft	1200 m 4000 ft	1800 m 6000 ft	2400 m 8000 ft	3000 m 10000 ft
Spring		Turquoise 417 115 900	←	Yellow/Green on Violet 417 118 500	←	←	←
Block		Qty 3 x 1 417 114 300	←	←	←	←	←
Weight		—	—	Qty 3 x 2 417 114 400	Qty 3 x 1 ←	Qty 3 x 1 ←	—
Capsule		Qty 3 x 2 417 114 500	←	Qty 3 x 1 ←	Qty 3 x 2 ←	Qty 3 x 2 ←	Qty 3 x 3 ←
Engagement RPM ± 100		3100	←	3500	←	←	←
Maximum RPM ± 100		6900	←	←	←	←	←

### DRIVEN PULLEY (Tundra R)

Altitude Clutching		Sea Level	600 m 2000 ft	1200 m 4000 ft	1800 m 6000 ft	2000 m 8000 ft	3000 m 10000 ft
Spring		Yellow 415 094 300	←	←	←	←	←
Spring tension	Kg ± 0.7 lb ± 1.5	0.00 Position3	←	←	←	←	←
Cam angle	° (degrees)	37.8 417 126 350	←	←	←	←	←

### DRIVEN PULLEY (Tundra)

Altitude Clutching		Sea Level	600 m 2000 ft	1200 m 4000 ft	1800 m 6000 ft	2000 m 8000 ft	3000 m 10000 ft
Spring		White 414 509 900	←	←	←	←	←
Spring tension	Kg ± 0.7 lb ± 1.5	3.6 7.9	←	5.9 13.0	←	←	←
Cam angle	° (degrees)	37.8 504 081 300	←	←	←	←	←

NOTE: Arrows in the charts indicate that the preceding information is repeated.

# 1999-TUNDRA/TUNDRA R

## ▼ CAUTION

These adjustments are guidelines only. Specific adjustments vary with temperature, altitude and snow conditions. Always observe spark plug condition for proper jetting.

### CARBURATION

Altitude		Sea Level	600 m 2000 ft	1200 m 4000 ft	1800 m 6000 ft	2400 m 8000 ft	3000 m 10000 ft	Qty
Calibration								
Main jet		190	185	175	150	140	130	1
Jet needle		6DH4	←	←	←	←	←	1
Needle position		2	←	←	←	←	←	—
Slide cut-away		2.5	←	←	←	←	←	1
Pilot jet		40	←	←	35	←	←	1
Air screw		1.0	←	←	←	←	←	—
Valve seat		1.5	←	←	←	←	←	1
Needle jet		O-8 (159)	←	←	←	←	←	1
Float level	mm	23.9	←	←	←	←	←	—

### (Tundra only)

Idle	RPM ± 200	1200	←	←	←	←	←	—
Idle throttle valve position	mm	1.3	←	←	1.5	←	←	—

### (Tundra R only)

Idle	RPM ± 200	1650	←	←	←	←	←	—
Idle throttle valve position	mm	1.5	←	←	1.7	←	←	—

### MAIN JET CHART

Altitude		Sea Level	600 m 2000 ft	1200 m 4000 ft	1800 m 6000 ft	2400 m 8000 ft	3000 m 10000 ft	Qty
Temperature								
- 40°C	- 40°F	210	200	190	170	160	150	1
- 30°C	- 20°F	200	190	180	160	150	140	1
<b>- 20°C</b>	<b>- 4°F</b>	<b>190</b>	<b>185</b>	<b>175</b>	<b>150</b>	<b>140</b>	<b>130</b>	<b>1</b>
- 10°C	14°F	185	180	170	145	135	125	1
0°C	32°F	180	175	165	140	130	120	1
10°C	50°F	170	165	155	130	120	110	1
20°C	70°F	165	160	150	125	115	105	1

NOTE: Arrows in the charts indicate that the preceding information is repeated.



 **WARNING**

For safety reasons, this kit must be installed by an authorized Bombardier snowmobile dealer. Should removal of a locking device be required when undergoing disassembly/assembly, always replace with a new one. This instruction sheet should be given to the purchaser. This kit is designed for specific models. It is not recommended for vehicles other than those for which it was sold.

 **CAUTION**

The following modifications and adjustments apply only for altitudes above 600 m (2 000 ft).

NOTE: Installation time is approximately 1.5 hours.

## MODIFICATIONS AND ADJUSTMENTS

The transmission and carburation charts list all parts as well as modifications and adjustments needed for altitude and/or temperature changes.

*High Altitude Technical Data* sheets (P/N 484 300 003) containing technical information pertaining to carburetor jetting, transmission calibration, conversion charts and more, are available. They cover all models for the last 5 years. A convenient binder (P/N 484 054 500) can be ordered to organize the set.

## CARBURETOR JETTING

Stock vehicle jetting and the main jets included in this kit are prescribed for a temperature of - 20°C (- 4°F), as indicated by **bold face type** on the main jet chart. Snowmobile utilization above or below this temperature requires a different jetting. In that case, find the required main jet size in "Carburation" chart and order it according to the Bombardier P/N (part numbers) given in "Main Jet" P/N chart that can be found in the previously mentioned *High Altitude Technical Data* sheets.

# PARTS TO BE INSTALLED

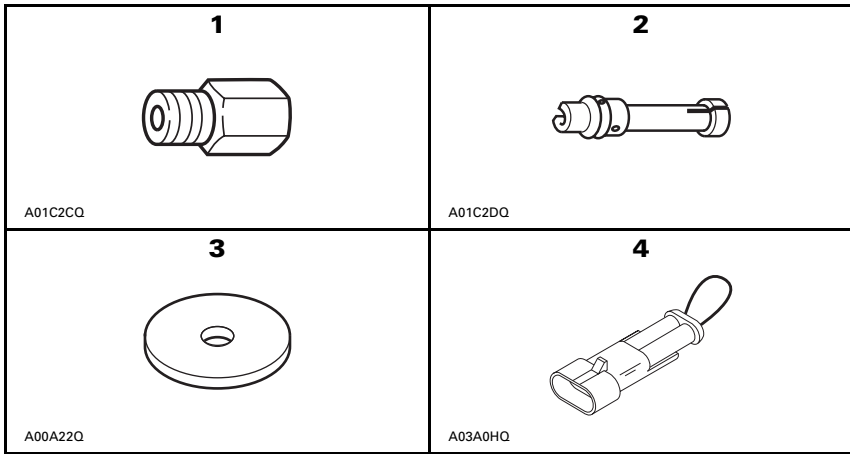

- |    |             |                   |           |      |
|----|-------------|-------------------|-----------|------|
| 1. | 404 130 400 | Main jet          | 135       | (2)  |
|    | 404 124 900 | Main jet          | 130       | (2)  |
|    | 404 124 800 | Main jet          | 125       | (2)  |
|    | 404 124 000 | Main jet          | 115       | (2)  |
|    | 404 124 100 | Main jet          | 110       | (2)  |
| 2. | 404 116 900 | Needle jet        | O-8 (159) | (2)  |
| 3. | 417 114 400 | Weight            |           | (15) |
| 4. | 515 174 700 | Reverse Connector |           | (1)  |

# 1999-FORMULA S/ DELUXE 380

## HIGH ALTITUDE KIT (P/N 861 767 500)

### DRIVE PULLEY

Altitude		Sea Level	600 m 2000 ft	1200 m 4000 ft	1800 m 6000 ft	2400 m 8000 ft	3000 m 10000 ft
Clutching							
Spring		Red/Blue 417 118 400	←	←	←	←	←
Block		Qty 3 x 1 417 118 100	←	←	←	←	←
Weight		Qty 3 x 1 417 120 400	←	Qty 3 x 5 417 114 400	Qty 3 x 4 ←	Qty 3 x 3 ←	Qty 3 x 2 ←
Capsule		Qty 3 x 1 417 114 500	←	←	←	←	←
Engagement RPM ± 100		3500	←	←	←	←	←
Maximum RPM ± 100		6900	←	←	←	←	←

### DRIVEN PULLEY (Formula S)

Altitude		Sea Level	600 m 2000 ft	1200 m 4000 ft	1800 m 6000 ft	2400 m 8000 ft	3000 m 10000 ft
Clutching							
Spring		Orange 414 505 800	←	←	←	←	←
Spring tension	Kg ± 0.7 lb ± 1.5	4.8 10.6	←	←	←	←	←
Cam angle	° (degrees)	44 417 126 333	←	←	←	←	←

### DRIVEN PULLEY (Formula Deluxe 380)

Altitude		Sea Level	600 m 2000 ft	1200 m 4000 ft	1800 m 6000 ft	2400 m 8000 ft	3000 m 10000 ft
Clutching							
Spring		Yellow 417 092 800	←	←	←	←	←
Spring tension	Kg ± 0.7 lb ± 1.5	0.00 Position 3	←	←	←	←	←
Cam angle	° (degrees)	47 - 44 417 124 700	←	←	←	←	←

### ELECTRONIC REVERSE (Formula Deluxe 380)

		Sea Level	600 m 2000 ft	1200 m 4000 ft	1800 m 6000 ft	2400 m 8000 ft	3000 m 10000 ft
Reverse Connector		515 174 800	←	←	←	515 174 700	←

NOTE: Arrows in the charts indicate that the preceding information is repeated.

# 1999-FORMULA S/ DELUXE 380

## ▼ CAUTION

These adjustments are guidelines only. Specific adjustments vary with temperature, altitude and snow conditions. Always observe spark plug condition for proper jetting.

### CARBURATION

Altitude		Sea Level	600 m 2000 ft	1200 m 4000 ft	1800 m 6000 ft	2400 m 8000 ft	3000 m 10000 ft	Qty
Calibration								
Main jet		140	135	130	125	115	110	2
Jet needle		6DP9	←	←	←	←	←	2
Needle position		3	←	←	2	←	←	—
Slide cut-away		2.5	←	←	←	←	←	2
Pilot jet		40	←	←	←	←	←	2
Air screw		1.25	←	←	1.5	←	←	2
Valve seat		1.5	←	←	←	←	←	2
Needle jet		P-0 (159)	←	←	O-8 (159)	←	←	2
Float level	mm	23.9	←	←	←	←	←	—
Idle	RPM ± 200	1650	←	←	←	←	←	—
Idle throttle valve position	mm	1.3	←	←	1.7	←	←	—

### MAIN JET CHART

Altitude		Sea Level	600 m 2000 ft	1200 m 4000 ft	1800 m 6000 ft	2400 m 8000 ft	3000 m 10000 ft	Qty
Temperature								
- 40°C	- 40°F	150	145	140	135	125	120	2
- 30°C	- 20°F	145	140	135	130	120	115	2
<b>- 20°C</b>	<b>- 4°F</b>	<b>140</b>	<b>135</b>	<b>130</b>	<b>125</b>	<b>115</b>	<b>110</b>	<b>2</b>
- 10°C	14°F	135	130	125	120	110	105	2
0°C	32°F	130	125	120	115	105	100	2
10°C	50°F	125	120	115	110	100	95	2
20°C	70°F	120	115	110	105	95	90	2

NOTE: Arrows in the charts indicate that the preceding information is repeated.





## **WARNING**

For safety reasons, this kit must be installed by an authorized Bombardier snowmobile dealer. Should removal of a locking device be required when undergoing disassembly/assembly, always replace with a new one. This instruction sheet should be given to the purchaser. This kit is designed for specific models. It is not recommended for vehicles other than those for which it was sold.



## **CAUTION**

The following modifications and adjustments apply only for altitudes above 600 m (2 000 ft).

**NOTE:** Installation time is approximately 1.5 hours.

## **MODIFICATIONS AND ADJUSTMENTS**

The transmission and carburation charts list all parts as well as modifications and adjustments needed for altitude and/or temperature changes.

*High Altitude Technical Data* sheets (P/N 484 300 003) containing technical information pertaining to carburetor jetting, transmission calibration, conversion charts and more, are available. They cover all models for the last 5 years. A convenient binder (P/N 484 054 500) can be ordered to organize the set.

## **CARBURETOR JETTING**

Stock vehicle jetting and the main jets included in this kit are prescribed for a temperature of - 20°C (- 4°F), as indicated by **bold face type** on the main jet chart. Snowmobile utilization above or below this temperature requires a different jetting. In that case, find the required main jet size in "Carburation" chart and order it according to the Bombardier P/N (part numbers) given in "Main Jet" P/N chart that can be found in the previously mentioned *High Altitude Technical Data* sheets.

# PARTS TO BE INSTALLED

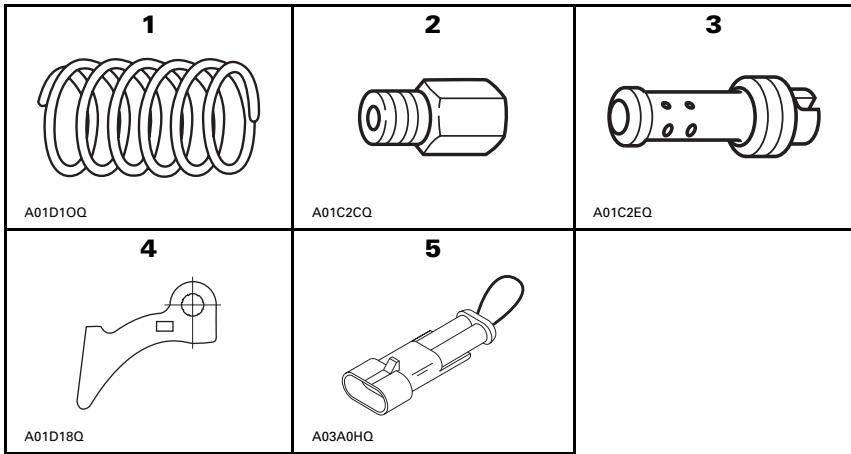

- |    |              |                   |             |     |
|----|--------------|-------------------|-------------|-----|
| 1. | 414 689 500  | Spring            | Blue/Yellow | (1) |
| 2. | 404 118 200  | Main jet          | 160         | (1) |
|    | 404 120 900  | Main jet          | 150         | (1) |
|    | 404 126 600  | Main jet          | 140         | (1) |
|    | 404 124 900  | Main jet          | 130         | (1) |
|    | 404 123 900  | Main jet          | 120         | (1) |
| 3. | 404 109 400  | Pilot jet         | 45          | (2) |
| 4. | 417 005 292X | Ramp              |             | (3) |
| 5. | 515 174 700  | Reverse Connector |             | (1) |

# 1999-FORMULA DELUXE 500/FORMULA SL

## HIGH ALTITUDE KIT (P/N 861 767 400)

### DRIVE PULLEY

Altitude Clutching	Sea Level	600 m 2000 ft	1200 m 4000 ft	1800 m 6000 ft	2400 m 8000 ft	3000 m 10000 ft
Spring	Yellow/Red 414 993 000	←	Blue/Yellow 414 689 500	←	←	←
Ramp	Qty 3 417 005 291X	←	Qty 3 417 005 292X	←	←	←
Calibration screw position	3	4	2	3	4	5
Pin	Qty 3 417 004 309	←	←	←	←	←
Engagement RPM ± 100	3300	←	3600	←	←	←
Maximum RPM ± 100	7000	←	←	←	←	←

### DRIVEN PULLEY (Formula SL)

Altitude Clutching	Sea Level	600 m 2000 ft	1200 m 4000 ft	1800 m 6000 ft	2400 m 8000 ft	3000 m 10000 ft
Spring	Orange 414 505 800	←	←	←	←	←
Spring tension	Kg ± 0.7 lb ± 1.5	4.8 10.6	←	←	←	←
Cam angle	° (degrees)	44 417 126 333	←	←	←	←

### DRIVEN PULLEY (Formula Deluxe 500)

Altitude Clutching	Sea Level	600 m 2000 ft	1200 m 4000 ft	1800 m 6000 ft	2400 m 8000 ft	3000 m 10000 ft
Spring	Yellow 415 092 800	←	←	←	←	←
Spring tension	Kg ± 0.7 lb ± 1.5	0.00 Position 3	←	←	←	←
Cam angle	° (degrees)	47 - 44 417 124 700	←	←	←	←

### REVERSE CONNECTOR (Formula Deluxe 500)

Altitude Clutching	Sea Level	600 m 2000 ft	1200 m 4000 ft	1800 m 6000 ft	2400 m 8000 ft	3000 m 10000 ft
Reverse Connector	515 174 800	←	←	←	515 174 700	←

NOTE: Arrows in the charts indicate that the preceding information is repeated.

# 1999-FORMULA DELUXE 500/FORMULA SL

## ▼ CAUTION

These adjustments are guidelines only. Specific adjustments vary with temperature, altitude and snow conditions. Always observe spark plug condition for proper jetting.

### CARBURETION

Altitude		Sea Level	600 m 2000 ft	1200 m 4000 ft	1800 m 6000 ft	2400 m 8000 ft	3000 m 10000 ft	Qty
Calibration								
Main jet		180 170	170 160	160 150	150 140	140 130	130 120	PTO MAG
Jet needle		6DH2	←	←	←	←	←	2
Needle position		3	←	←	2	←	←	—
Slide cut-away		2.5	←	←	←	←	←	2
Pilot jet		40	←	←	45	←	←	2
Air screw		1.875	←	←	1.5	←	←	—
Valve seat		1.5	←	←	←	←	←	2
Needle jet		P-0 (159)	←	←	←	←	←	2
Float level	mm	23.9	←	←	←	←	←	—
Idle	RPM ± 200	1650	←	←	←	←	←	—
Idle throttle valve position	mm	1.5	←	1.6	1.7	1.8	1.85	—

**NOTE:** Arrows in the charts indicate that the preceding information is repeated.

### MAIN JET CHART

Altitude		Sea Level	600 m 2000 ft	1200 m 4000 ft	1800 m 6000 ft	2400 m 8000 ft	3000 m 10000 ft	
Calibration								
- 40°C		200	190	175	165	155	140	PTO MAG
- 40°F		190	180	165	155	145	130	
- 30°C		190	180	165	155	145	135	PTO MAG
- 20°F		180	170	155	145	135	125	
<b>- 20°C</b>		<b>180</b>	<b>170</b>	<b>160</b>	<b>150</b>	<b>140</b>	<b>130</b>	<b>PTO MAG</b>
<b>- 4°F</b>		<b>170</b>	<b>160</b>	<b>150</b>	<b>140</b>	<b>130</b>	<b>120</b>	
- 10°C		170	160	155	145	135	125	PTO MAG
- 14°F		160	150	145	135	125	115	
0°C		165	155	150	140	130	120	PTO MAG
32°F		155	145	140	130	120	110	
10°C		160	150	140	130	125	115	PTO MAG
50°F		150	140	130	120	115	105	
20°C		155	145	135	125	120	110	PTO MAG
70°F		145	135	125	115	110	100	



## **WARNING**

For safety reasons, this kit must be installed by an authorized Bombardier snowmobile dealer. Should removal of a locking device be required when undergoing disassembly/assembly, always replace with a new one. This instruction sheet should be given to the purchaser. This kit is designed for specific models. It is not recommended for vehicles other than those for which it was sold.



## **CAUTION**

The following modifications and adjustments apply only for altitudes above 600 m (2 000 ft).

**NOTE:** Installation time is approximately 1.5 hours.

## **MODIFICATIONS AND ADJUSTMENTS**

The transmission and carburation charts list all parts as well as modifications and adjustments needed for altitude and/or temperature changes.

*High Altitude Technical Data* sheets (P/N 484 300 003) containing technical information pertaining to carburetor jetting, transmission calibration, conversion charts and more, are available. They cover all models for the last 5 years. A convenient binder (P/N 484 054 500) can be ordered to organize the set.

## **CARBURETOR JETTING**

Stock vehicle jetting and the main jets included in this kit are prescribed for a temperature of - 20°C (- 4°F), as indicated by **bold face type** on the main jet chart. Snowmobile utilization above or below this temperature requires a different jetting. In that case, find the required main jet size in "Carburation" chart and order it according to the Bombardier P/N (part numbers) given in "Main Jet" P/N chart that can be found in the previously mentioned *High Altitude Technical Data* sheets.

# PARTS TO BE INSTALLED

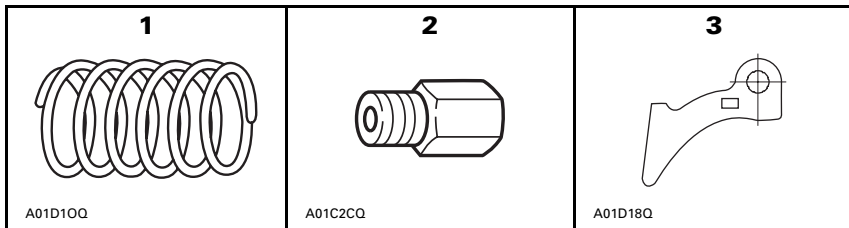

- |    |              |          |            |     |
|----|--------------|----------|------------|-----|
| 1. | 414 817 700  | Spring   | Blue/Green | (1) |
| 2. | 404 119 500  | Main jet | 185        | (1) |
|    | 404 119 200  | Main jet | 175        | (1) |
|    | 404 119 300  | Main jet | 165        | (1) |
|    | 404 128 700  | Main jet | 155        | (1) |
|    | 404 130 500  | Main jet | 145        | (1) |
| 3. | 417 005 292X | Ramp     |            | (3) |

# 1999-MX Z 440

## HIGH ALTITUDE KIT (P/N 861 767 900)

### DRIVE PULLEY

Altitude Clutching		Sea Level	600 m 2000 ft	1200 m 4000 ft	1800 m 6000 ft	2400 m 8000 ft	3000 m 10000 ft
Spring		Blue/Yellow 414 689 500	←	Blue/Green 414 817 700	←	←	←
Ramp		Qty 3 x 1 417 005 291X	←	Qty 3 x 1 417 005 292X	←	←	←
Calibration screw position		3	4	2	3	4	5
Pin		Qty 3 x 1 417 004 309	←	←	←	←	←
Engagement RPM ± 100		3700	←	←	←	←	←
Maximum RPM ± 100		7000	←	←	←	←	←

### DRIVEN PULLEY

Altitude Clutching		Sea Level	600 m 2000 ft	1200 m 4000 ft	1800 m 6000 ft	2400 m 8000 ft	3000 m 10000 ft
Spring		Orange 414 505 800	←	←	←	←	←
Spring tension	Kg ± 0.7 lb ± 1.5	6.1 13.4	←	←	←	←	←
Cam angle	° (degrees)	47 417 126 337	←	←	←	←	←

**NOTE:** Arrows in the charts indicate that the preceding information is repeated.

# 1999-MX Z 440

## ▼ CAUTION

These adjustments are guidelines only. Specific adjustments vary with temperature, altitude and snow conditions. Always observe spark plug condition for proper jetting.

### CARBURATION

Altitude		Sea Level	600 m 2000 ft	1200 m 4000 ft	1800 m 6000 ft	2400 m 8000 ft	3000 m 10000 ft	Qty
Calibration								
Main jet		205 195	195 185	185 175	175 165	165 155	155 145	PTO MAG
Jet needle		6DH2	←	←	←	←	←	2
Needle position		3	←	←	2	←	1	—
Slide cut-away		2.5	←	←	←	←	←	2
Pilot jet		35	←	←	←	←	←	2
Air screw		1.5	←	←	1.0	←	←	—
Valve seat		1.5	←	←	←	←	←	2
Needle jet		P-0 (159)	←	←	←	←	←	2
Float level	mm	23.9	←	←	←	←	←	—
Idle	RPM ± 200	1650	←	←	←	←	←	—
Idle throttle valve position	mm	1.5	←	1.6	1.8	1.9	2.0	—

### MAIN JET CHART

Altitude		Sea Level	600 m 2000 ft	1200 m 4000 ft	1800 m 6000 ft	2400 m 8000 ft	3000 m 10000 ft	
Temperature								
- 40°C - 40°F		215 205	205 195	195 185	185 175	180 170	170 160	PTO MAG
- 30°C - 20°F		210 200	200 190	190 180	180 170	170 160	160 150	PTO MAG
<b>- 20°C - 4°F</b>		<b>205 195</b>	<b>195 185</b>	<b>185 175</b>	<b>175 165</b>	<b>165 155</b>	<b>155 145</b>	<b>PTO MAG</b>
- 10°C 14°F		200 190	190 180	180 170	170 160	160 150	150 140	PTO MAG
0°C 32°F		195 185	185 175	175 165	165 155	155 145	145 135	PTO MAG
10°C 50°F		185 175	175 165	165 155	155 145	145 135	140 130	PTO MAG
20°C 70°F		180 170	170 160	160 150	150 140	140 130	135 125	PTO MAG

**NOTE:** Arrows in the charts indicate that the preceding information is repeated.





 **WARNING**

For safety reasons, this kit must be installed by an authorized Bombardier snowmobile dealer. Should removal of a locking device be required when undergoing disassembly/assembly, always replace with a new one. This instruction sheet should be given to the purchaser. This kit is designed for specific models. It is not recommended for vehicles other than those for which it was sold.

 **CAUTION**

The following modifications and adjustments apply only for altitudes above 600 m (2 000 ft).

NOTE: Installation time is approximately 1.5 hours.

## MODIFICATIONS AND ADJUSTMENTS

The transmission and carburation charts list all parts as well as modifications and adjustments needed for altitude and/or temperature changes.

*High Altitude Technical Data* sheets (P/N 484 300 003) containing technical information pertaining to carburetor jetting, transmission calibration, conversion charts and more, are available. They cover all models for the last 5 years. A convenient binder (P/N 484 054 500) can be ordered to organize the set.

## CARBURETOR JETTING

Stock vehicle jetting and the main jets included in this kit are prescribed for a temperature of - 20°C (- 4°F), as indicated by **bold face type** on the main jet chart. Snowmobile utilization above or below this temperature requires a different jetting. In that case, find the required main jet size in "Carburation" chart and order it according to the Bombardier P/N (part numbers) given in "Main Jet" P/N chart that can be found in the previously mentioned *High Altitude Technical Data* sheets.

# PARTS TO BE INSTALLED

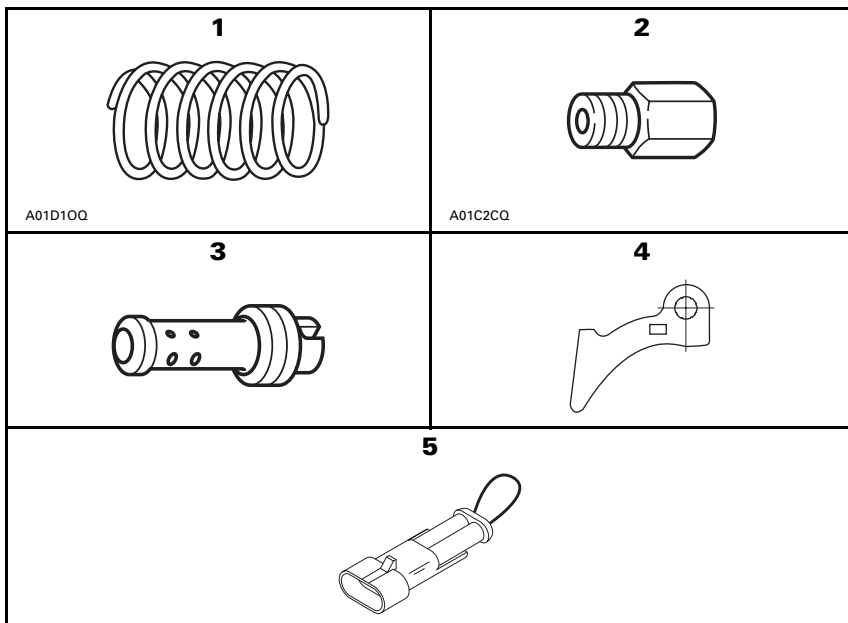

- |    |             |                   |              |     |
|----|-------------|-------------------|--------------|-----|
| 1. | 414 742 100 | Spring            | Yellow/Green | (1) |
| 2. | 404 118 200 | Main jet          | 160          | (1) |
|    | 404 120 900 | Main jet          | 150          | (1) |
|    | 404 126 600 | Main jet          | 140          | (1) |
|    | 404 124 900 | Main jet          | 130          | (1) |
|    | 404 123 900 | Main jet          | 120          | (1) |
| 3. | 404 109 400 | Pilot jet         | 45           | (2) |
| 4. | 417 005 284 | Ramp              | 284          | (3) |
| 5. | 515 174 700 | Reverse connector |              | (1) |

# 1999-TOURING SLE/ SKANDIC 500

## HIGH ALTITUDE KIT (P/N 861 768 400)

### DRIVE PULLEY

Altitude Clutching	Sea Level	600 m 2000 ft	1200 m 4000 ft	1800 m 6000 ft	2400 m 8000 ft	3000 m 10000 ft
Spring	Red/Red 414 689 800	←	Yellow/Green 414 742 100	←	←	←
Ramp <sup>Ⓞ</sup>	Qty 3 x 1 417 005 291X	←	Qty 3 x 1 417 005 284	←	←	←
Calibration screw position	3	4	2	3	4	5
Pin	Qty 3 x 1 417 004 309	←	←	←	←	←
Engagement RPM ± 100	2900	←	3300	←	←	←
Maximum RPM ± 100	7000	←	←	←	←	←

<sup>Ⓞ</sup>NOTE: On Skandic 500, the part number of the ramp is 417 005 292X.

### DRIVEN PULLEY

Altitude Clutching	Sea Level	600 m 2000 ft	1200 m 4000 ft	1800 m 6000 ft	2400 m 8000 ft	3000 m 10000 ft
Spring	Yellow 415 092 800	←	←	←	←	←
Spring tension	Kg ± 0.7 lb ± 1.5	0.00	Position 3	←	←	←
Cam angle	° (degrees)	47 - 44	←	←	←	←
		417 124 700				

### ELECTRONIC REVERSE

	Sea Level	600 m 2000 ft	1200 m 4000 ft	1800 m 6000 ft	2400 m 8000 ft	3000 m 10000 ft
Reverse Connector	515 174 800	←	←	←	515 174 700	←

NOTE: Arrows in the charts indicate that the preceding information is repeated.

# 1999-TOURING SLE/ SKANDIC 500

## ▼ CAUTION

These adjustments are guidelines only. Specific adjustments vary with temperature, altitude and snow conditions. Always observe spark plug condition for proper jetting.

### CARBURATION

Altitude		Sea Level	600 m 2000 ft	1200 m 4000 ft	1800 m 6000 ft	2400 m 8000 ft	3000 m 10000 ft	Qty
Calibration								
Main jet		180 170	170 160	160 150	150 140	140 130	130 120	PTO MAG
Jet needle		6DH2	←	←	←	←	←	2
Needle position		3	←	←	←	←	←	—
Slide cut-away		2.5	←	←	←	←	←	2
Pilot jet		40	←	←	45	←	←	2
Air screw		1.88	←	←	0.750	←	←	—
Valve seat		1.5	←	←	←	←	←	2
Needle jet		P-0 (159)	←	←	←	←	←	2
Float level	mm	23.9	←	←	←	←	←	—
Idle	RPM ± 200	1650	←	←	1550	←	←	—
Idle throttle valve position	mm	1.5	1.8	2.1	2.4	2.5	2.6	—

### MAIN JET CHART

Altitude		Sea Level	600 m 2000 ft	1200 m 4000 ft	1800 m 6000 ft	2400 m 8000 ft	3000 m 10000 ft	
Calibration								
- 40°C - 40°F		200 190	190 180	175 165	165 155	155 145	140 130	PTO MAG
- 30°C - 20°F		190 180	180 170	165 155	155 145	145 135	135 125	PTO MAG
<b>- 20°C - 4°F</b>		<b>180 170</b>	<b>170 160</b>	<b>160 150</b>	<b>150 140</b>	<b>140 130</b>	<b>130 120</b>	<b>PTO MAG</b>
- 10°C 14°F		170 160	160 150	155 145	145 135	135 125	125 115	PTO MAG
0°C 32°F		165 155	155 145	150 140	140 130	130 120	120 110	PTO MAG
10°C 50°F		160 150	150 140	140 130	130 120	125 115	115 105	PTO MAG
20°C 70°F		155 145	145 135	135 125	125 115	120 110	110 100	PTO MAG

**NOTE:** Arrows in the charts indicate that the preceding information is repeated.



 **WARNING**

For safety reasons, this kit must be installed by an authorized Bombardier snowmobile dealer. Should removal of a locking device be required when undergoing disassembly/assembly, always replace with a new one. This instruction sheet should be given to the purchaser. This kit is designed for specific models. It is not recommended for vehicles other than those for which it was sold.

 **CAUTION**

The following modifications and adjustments apply only for altitudes above 600 m (2000 ft).

**NOTE:** Installation time is approximately 1.5 hours.

## MODIFICATIONS AND ADJUSTMENTS

The transmission and carburation charts list all parts as well as modifications and adjustments needed for altitude and/or temperature changes.

*High Altitude Technical Data* sheets (P/N 484 300 003) containing technical information pertaining to carburetor jetting, transmission calibration, conversion charts and more, are available. They cover all models for the last 5 years. A convenient binder (P/N 484 054 500) can be ordered to organize the set.

## CARBURETOR JETTING

Stock vehicle jetting and the main jets included in this kit are prescribed for a temperature of  $-20^{\circ}\text{C}$  ( $-4^{\circ}\text{F}$ ), as indicated by **bold face type** on the main jet chart. Snowmobile utilization above or below this temperature requires a different jetting. In that case, find the required main jet size in "Carburation" chart and order it according to the Bombardier P/N (part numbers) given in "Main Jet" P/N chart that can be found in the previously mentioned *High Altitude Technical Data* sheets.

# PARTS TO BE INSTALLED

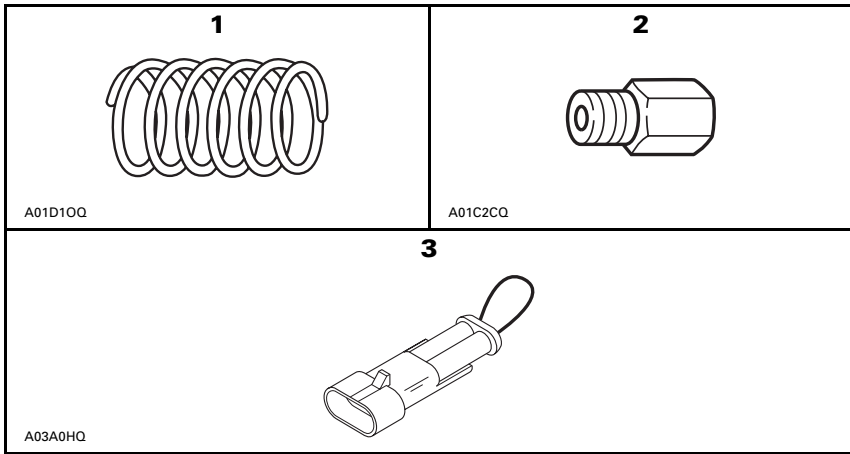

- |    |             |                   |              |     |
|----|-------------|-------------------|--------------|-----|
| 1. | 414 742 100 | Spring            | Yellow/Green | (1) |
| 2. | 404 119 500 | Main jet          | 185          | (1) |
|    | 404 119 200 | Main jet          | 175          | (1) |
|    | 404 119 300 | Main jet          | 165          | (1) |
|    | 404 128 700 | Main jet          | 155          | (1) |
|    | 404 130 500 | Main jet          | 145          | (1) |
| 3. | 515 174 700 | Reverse connector |              | (1) |

# 1999-TOURING LE

## HIGH ALTITUDE KIT (P/N 861 768 500)

### DRIVE PULLEY

Altitude Clutching	Sea Level	600 m 2000 ft	1200 m 4000 ft	1800 m 6000 ft	2400 m 8000 ft	3000 m 10000 ft
Spring	Red/Yellow 414 817 500	←	Yellow/Green 414 742 100	←	←	←
Ramp	Qty 3 x 1 417 005 284	←	←	←	←	←
Calibration screw position	2	3	2	3	4	5
Pin	417 004 309	←	←	←	←	←
Engagement RPM ± 100	2900	←	3300	←	←	←
Maximum RPM ± 100	7000	←	←	←	←	←

### DRIVEN PULLEY

Altitude Clutching	Sea Level	600 m 2000 ft	1200 m 4000 ft	1800 m 6000 ft	2400 m 8000 ft	3000 m 10000 ft
Spring	Yellow 415 092 800	←	←	←	←	←
Spring tension	Kg ± 0.7 lb ± 1.5	0.0	Position 3	0.0	←	←
Cam angle	° (degrees)	47 - 44	417 124 700	←	←	←

### ELECTRONIC REVERSE

Altitude Clutching	Sea Level	600 m 2000 ft	1200 m 4000 ft	1800 m 6000 ft	2400 m 8000 ft	3000 m 10000 ft
Reverse connector	515 174 800	←	←	←	515 174 700	←

**NOTE:** Arrows in the charts indicate that the preceding information is repeated.

# 1999-TOURING LE

## ▼ CAUTION

These adjustments are guidelines only. Specific adjustments vary with temperature, altitude and snow conditions. Always observe spark plug condition for proper jetting.

### CARBURATION

Altitude		Sea Level	600 m 2000 ft	1200 m 4000 ft	1800 m 6000 ft	2400 m 8000 ft	3000 m 10000 ft	Qty
Calibration								
Main jet		205 195	195 185	185 175	175 165	165 155	155 145	PTO MAG
Jet needle		6DH2	←	←	←	←	←	2
Needle position		3	←	←	2	←	1	—
Slide cut-away		2.5	←	←	←	←	←	2
Pilot jet		35	←	←	←	←	←	2
Air screw		1.50	←	←	1.0	←	←	—
Valve seat		1.5	←	←	←	←	←	2
Needle jet		P-0(159)	←	←	←	←	←	2
Float level	mm	23.9	←	←	←	←	←	—
Idle	RPM ± 200	1650	←	←	←	←	←	—
Idle throttle valve position	mm	1.5	←	1.6	1.8	1.9	2.0	—

### MAIN JET CHART

Altitude		Sea Level	600 m 2000 ft	1200 m 4000 ft	1800 m 6000 ft	2400 m 8000 ft	3000 m 10000 ft	
Temperature								
- 40°C		215	205	195	185	180	170	PTO MAG
- 40°F		205	195	185	175	170	160	
- 30°C		210	200	190	180	170	160	PTO MAG
- 20°F		200	190	180	170	160	150	
- 20°C		205	195	185	175	165	155	<b>PTO MAG</b>
- 4°F		195	185	175	165	155	145	
- 10°C		200	190	180	170	160	150	PTO MAG
14°F		190	180	170	160	150	140	
0°C		195	185	175	165	155	145	PTO MAG
32°F		185	175	165	155	145	135	
10°C		185	175	165	155	145	140	PTO MAG
50°F		175	165	155	145	135	130	
20°C		180	170	160	150	140	135	PTO MAG
70°F		170	160	150	140	130	125	

**NOTE:** Arrows in the charts indicate that the preceding information is repeated.





 **WARNING**

For safety reasons, this kit must be installed by an authorized Bombardier snowmobile dealer. Should removal of a locking device be required when undergoing disassembly/assembly, always replace with a new one. This instruction sheet should be given to the purchaser. This kit is designed for specific models. It is not recommended for vehicles other than those for which it was sold.

 **CAUTION**

The following modifications and adjustments apply only for altitudes above 600 m (2 000 ft).

NOTE: Installation time is approximately 1.5 hours.

## MODIFICATIONS AND ADJUSTMENTS

The transmission and carburation charts list all parts as well as modifications and adjustments needed for altitude and/or temperature changes.

*High Altitude Technical Data* sheets (P/N 484 300 003) containing technical information pertaining to carburetor jetting, transmission calibration, conversion charts and more, are available. They cover all models for the last 5 years. A convenient binder (P/N 484 054 500) can be ordered to organize the set.

## CARBURETOR JETTING

Stock vehicle jetting and the main jets included in this kit are prescribed for a temperature of - 20°C (- 4°F), as indicated by **bold face type** on the main jet chart. Snowmobile utilization above or below this temperature requires a different jetting. In that case, find the required main jet size in "Carburation" chart and order it according to the Bombardier P/N (part numbers) given in "Main Jet" P/N chart that can be found in the previously mentioned *High Altitude Technical Data* sheets.

# PARTS TO BE INSTALLED

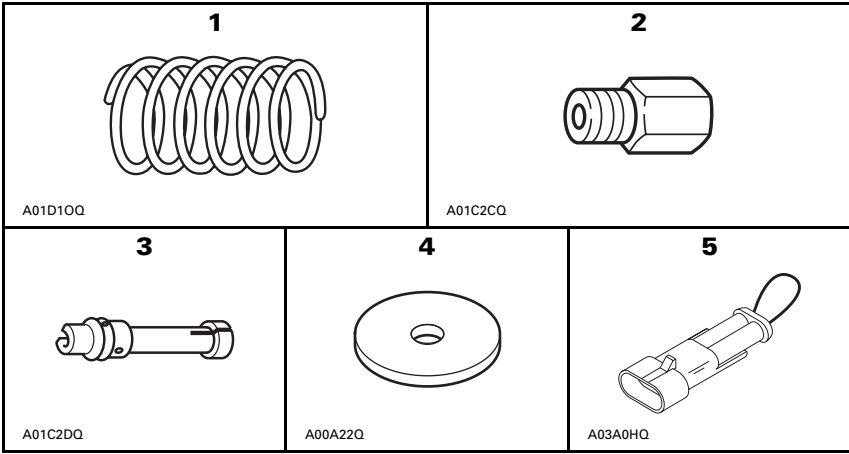

- |    |             |                   |                    |      |
|----|-------------|-------------------|--------------------|------|
| 1. | 417 118 400 | Spring            | Red/Blue on Violet | (1)  |
| 2. | 404 130 400 | Main jet          | 135                | (2)  |
|    | 404 124 900 | Main jet          | 130                | (2)  |
|    | 404 124 800 | Main jet          | 125                | (2)  |
|    | 404 124 000 | Main jet          | 115                | (2)  |
|    | 404 124 100 | Main jet          | 110                | (2)  |
| 3. | 404 116 900 | Needle jet        | O-8 (159)          | (2)  |
| 4. | 417 114 400 | Weight            |                    | (15) |
| 5. | 515 174 700 | Reverse connector |                    | (1)  |

# 1999-TOURING E/ SKANDIC 380

## HIGH ALTITUDE KIT (P/N 861 768 600)

### DRIVE PULLEY

Altitude Clutching	Sea Level	600 m 2000 ft	1200 m 4000 ft	1800 m 6000 ft	2400 m 8000 ft	3000 m 10000 ft
Spring	Green/Green on Violet 417 125 300	←	Red/Blue on Violet 417 118 400	←	←	←
Block	Qty 3 x 1 417 118 100	←	←	←	←	←
Weight	Qty 3 x 1 417 120 400	←	Qty 3 x 5 417 114 400	Qty 3 x 4 ←	Qty 3 x 3 ←	Qty 3 x 2 ←
Capsule	Qty 3 x 1 417 114 500	←	←	←	←	←
Engagement RPM ± 100	2500	←	3100	←	←	←
Maximum RPM ± 100	6900	←	←	←	←	←

### DRIVEN PULLEY

Altitude Clutching	Sea Level	600 m 2000 ft	1200 m 4000 ft	1800 m 6000 ft	2400 m 8000 ft	3000 m 10000 ft
Spring	Yellow 415 092 800	←	←	←	←	←
Spring tension	Kg ± 0.7 lb ± 1.5	0.0 Position 3 0.0	←	←	←	←
Cam angle	° (degrees)	47 - 44 417 124 700	←	←	←	←

### ELECTRONIC REVERSE

Sea Level	600 m 2000 ft	1200 m 4000 ft	1800 m 6000 ft	2400 m 8000 ft	3000 m 10000 ft	
Reverse connector	515 174 800	←	←	←	515 174 700	←

NOTE: Arrows in the charts indicate that the preceding information is repeated.

# 1999-TOURING E/ SKANDIC 380

## ▼ CAUTION

These adjustments are guidelines only. Specific adjustments vary with temperature, altitude and snow conditions. Always observe spark plug condition for proper jetting.

### CARBURATION

Altitude		Sea Level	600 m 2000 ft	1200 m 4000 ft	1800 m 6000 ft	2400 m 8000 ft	3000 m 10000 ft	Qty
Calibration								
Main jet		140	135	130	125	115	110	2
Jet needle		6DP9	←	←	←	←	←	2
Needle position		3	←	←	2	←	←	—
Slide cut-away		2.5	←	←	←	←	←	2
Pilot jet		40	←	←	←	←	←	2
Air screw		1.25	←	←	1.5 <sup>①</sup>	←	←	2
Valve seat		1.5	←	←	←	←	←	2
Needle jet		P-0 (159)	←	←	O-8 (159)	←	←	2
Float level	mm	23.9	←	←	←	←	←	—
Idle	RPM ± 200	1650	←	←	←	←	←	—
Idle throttle valve position	mm	1.3	←	←	1.7	←	←	—

① On Skandic 380, from 1800 m (4000 ft) and over, carburetor air screw must be positioned at 0.5 turn on PTO side and at 1.0 turn on MAG side.

### MAIN JET CHART

Altitude		Sea Level	600 m 2000 ft	1200 m 4000 ft	1800 m 6000 ft	2400 m 8000 ft	3000 m 10000 ft	Qty
Temperature								
- 40°C - 40°F		150	145	140	135	125	120	2
- 30°C - 20°F		145	140	135	130	120	115	2
<b>- 20°C - 4°F</b>		<b>140</b>	<b>135</b>	<b>130</b>	<b>125</b>	<b>115</b>	<b>110</b>	<b>2</b>
- 10°C 14°F		135	130	125	120	110	105	2
0°C 32°F		130	125	120	115	105	100	2
10°C 50°F		125	120	115	110	100	95	2
20°C 70°F		120	115	110	105	95	90	2

**NOTE:** Arrows in the charts indicate that the preceding information is repeated.



 **WARNING**

For safety reasons, this kit must be installed by an authorized Bombardier snowmobile dealer. Should removal of a locking device be required when undergoing disassembly/assembly, always replace with a new one. This instruction sheet should be given to the purchaser. This kit is designed for specific models. It is not recommended for vehicles other than those for which it was sold.

 **CAUTION**

The following modifications and adjustments apply only for altitudes above 600 m (2000 ft).

**NOTE:** Installation time is approximately 1.5 hours.

## MODIFICATIONS AND ADJUSTMENTS

The transmission and carburation charts list all parts as well as modifications and adjustments needed for altitude and/or temperature changes.

*High Altitude Technical Data* sheets (P/N 484 300 003) containing technical information pertaining to carburetor jetting, transmission calibration, conversion charts and more, are available. They cover all models for the last 5 years. A convenient binder (P/N 484 054 500) can be ordered to organize the set.

## CARBURETOR JETTING

Stock vehicle jetting and the main jets included in this kit are prescribed for a temperature of - 20°C (- 4°F), as indicated by **bold face type** on the main jet chart. Snowmobile utilization above or below this temperature requires a different jetting. In that case, find the required main jet size in "Carburation" chart and order it according to the Bombardier P/N (part numbers) given in "Main Jet" P/N chart that can be found in the previously mentioned *High Altitude Technical Data* sheets.

# PARTS TO BE INSTALLED

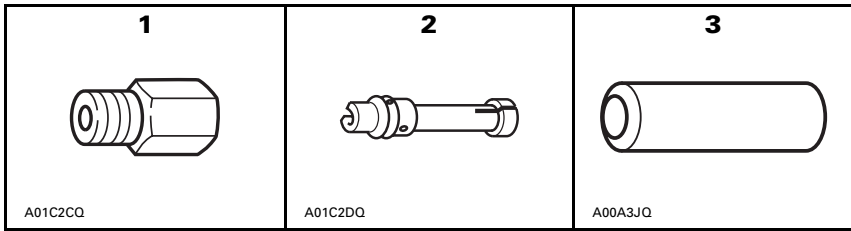

- |    |             |            |            |     |
|----|-------------|------------|------------|-----|
| 1. | 404 100 400 | Main jet   | 270        | (1) |
|    | 404 100 600 | Main jet   | 260        | (1) |
|    | 404 100 200 | Main jet   | 240        | (1) |
|    | 404 111 200 | Main jet   | 220        | (1) |
|    | 404 119 100 | Main jet   | 210        | (1) |
|    | 404 112 300 | Main jet   | 200        | (1) |
|    | 404 119 000 | Main jet   | 190        | (1) |
|    | 404 119 200 | Main jet   | 175        | (1) |
| 2. | 404 133 500 | Needle jet | AA-0 (224) | (2) |
|    | 404 155 400 | Needle jet | AA-1 (224) | (2) |
| 3. | 417 004 309 | Pin        |            | (3) |

# 1999-FORMULA Z 670/FORMULA DLX 670

## HIGH ALTITUDE KIT (P/N 861 767 100)

### DRIVE PULLEY

Altitude		Sea Level	600 m 2000 ft	1200 m 4000 ft	1800 m 6000 ft	2400 m 8000 ft	3000 m 10000 ft
Clutching							
Spring		Violet/Yellow 415 015 300	←	←	←	←	←
Ramp		417 005 286	←	←	←	←	←
Calibration screw position		3	4	5	4	5	6
Pin		Qty 3 x 1 417 004 308	←	←	Qty 3 x 1 417 004 309	←	←
Engagement RPM ± 100		3800	←	←	4500	←	←
Maximum RPM ± 100		7700	←	←	←	←	←

### DRIVEN PULLEY

Altitude		Sea Level	600 m 2000 ft	1200 m 4000 ft	1800 m 6000 ft	2000 m 8000 ft	3000 m 10000 ft
Clutching							
Spring		Beige 414 558 900	←	←	←	←	←
Spring tension	Kg ± 0.7 lb ± 1.5	7.0 15.4	←	←	←	←	←
Cam angle	° (degrees)	50 417 126 343	←	←	←	←	←

**NOTE:** Arrows in the charts indicate that the preceding information is repeated.

**Additional Information:** Unscrew Rave Valve adjuster screws approximately three (3) turns at and above 2400 m/8000 ft.

**Recommendation:** At and above 2400 m/8000 ft **or** in deep snow; chaincase ratio: 23/43 with 72 links chain, (P/N 412 106 700), sprocket 23 teeth, large, (P/N 504 085 400).

# 1999-FORMULA Z 670/FORMULA DLX 670

## ▼ CAUTION

These adjustments are guidelines only. Specific adjustments vary with temperature, altitude and snow conditions. Always observe spark plug condition for proper jetting.

### CARBURATION

Altitude		Sea Level	600 m 2000 ft	1200 m 4000 ft	1800 m 6000 ft	2400 m 8000 ft	3000 m 10000 ft	Qty
Calibration								
Main jet		310 290	290 270	260 240	240 220	210 200	190 175	PTO MAG
Jet needle		7EDY1	←	←	←	←	←	2
Needle position		3	←	←	2	←	←	—
Slide cut-away		2.5	←	←	←	←	←	2
Pilot jet		60	←	←	←	←	←	2
Air screw		2.25	←	2.00	1.75	1.50	1.25	—
Valve seat		1.5	←	←	←	←	←	2
Needle jet		AA-3 (224)	←	←	AA-1 (224)	←	AA-0 (224)	2
Float level	mm	18.1	←	←	←	←	←	—
Idle	RPM ± 200	1700	←	←	←	←	←	—
Idle throttle valve position	mm	2.10	2.15	2.25	2.40	2.55	2.65	—

### MAIN JET CHART

Altitude		Sea Level	600 m 2000 ft	1200 m 4000 ft	1800 m 6000 ft	2400 m 8000 ft	3000 m 10000 ft	
Temperature								
- 40°C - 40°F		330 310	310 290	280 260	260 240	230 210	210 190	PTO MAG
- 30°C - 20°F		320 300	300 280	270 250	250 230	220 200	200 180	PTO MAG
<b>- 20°C - 4°F</b>		<b>310 290</b>	<b>290 270</b>	<b>260 240</b>	<b>240 220</b>	<b>210 200</b>	<b>190 175</b>	<b>PTO MAG</b>
- 10°C 14°F		300 280	280 260	250 230	230 210	200 190	185 170	PTO MAG
0°C 32°F		290 270	270 250	240 220	220 200	195 185	175 160	PTO MAG
10°C 50°F		270 250	250 240	230 210	210 195	185 175	170 155	PTO MAG
20°C 70°F		260 240	240 230	220 200	200 185	185 170	160 150	PTO MAG

**NOTE:** Arrows in the charts indicate that the preceding information is repeated.





## **WARNING**

For safety reasons, this kit must be installed by an authorized Bombardier snowmobile dealer. Should removal of a locking device be required when undergoing disassembly/assembly, always replace with a new one. This instruction sheet should be given to the purchaser. This kit is designed for specific models. It is not recommended for vehicles other than those for which it was sold.



## **CAUTION**

The following modifications and adjustments apply only for altitudes above 600 m (2 000 ft).

**NOTE:** Installation time is approximately 1.5 hours.

## **MODIFICATIONS AND ADJUSTMENTS**

The transmission and carburation charts list all parts as well as modifications and adjustments needed for altitude and/or temperature changes.

*High Altitude Technical Data* sheets (P/N 484 300 003) containing technical information pertaining to carburetor jetting, transmission calibration, conversion charts and more, are available. They cover all models for the last 5 years. A convenient binder (P/N 484 054 500) can be ordered to organize the set.

## **CARBURETOR JETTING**

Stock vehicle jetting and the main jets included in this kit are prescribed for a temperature of - 20°C (- 4°F), as indicated by **bold face type** on the main jet chart. Snowmobile utilization above or below this temperature requires a different jetting. In that case, find the required main jet size in "Carburation" chart and order it according to the Bombardier P/N (part numbers) given in "Main Jet" P/N chart that can be found in the previously mentioned *High Altitude Technical Data* sheets.

# PARTS TO BE INSTALLED

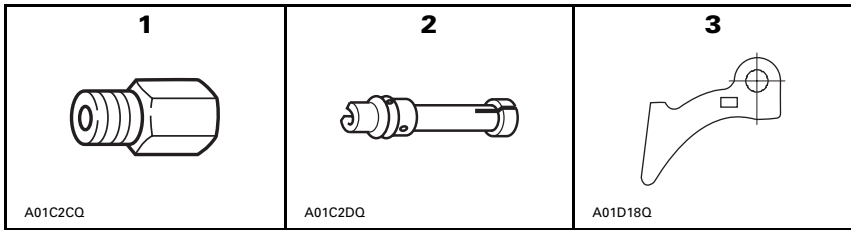

- |    |             |            |     |     |
|----|-------------|------------|-----|-----|
| 1. | 404 100 300 | Main jet   | 250 | (1) |
|    | 404 100 200 | Main jet   | 240 | (1) |
|    | 404 118 900 | Main jet   | 230 | (1) |
|    | 404 111 200 | Main jet   | 220 | (1) |
|    | 404 119 100 | Main jet   | 210 | (1) |
|    | 404 112 300 | Main jet   | 200 | (1) |
|    | 404 119 400 | Main jet   | 195 | (1) |
|    | 404 119 000 | Main jet   | 190 | (1) |
|    | 404 119 500 | Main jet   | 185 | (1) |
|    | 404 112 200 | Main jet   | 180 | (1) |
|    | 404 123 800 | Main jet   | 170 | (1) |
|    | 404 120 900 | Main jet   | 150 | (1) |
| 2. | 404 131 500 | Needle jet |     | (2) |
|    | 404 157 300 | Needle jet |     | (2) |
|    | 404 133 500 | Needle jet |     | (2) |
| 3. | 417 005 289 | Ramp       | 289 | (3) |

# 1999-FORMULA Z 583/FORMULA DLX 583

## HIGH ALTITUDE KIT (P/N 861 767 200)

### DRIVE PULLEY

Altitude Clutching	Sea Level	600 m 2000 ft	1200 m 4000 ft	1800 m 6000 ft	2400 m 8000 ft	3000 m 10000 ft
Spring	Violet/Blue 415 034 900	←	←	←	←	←
Ramp	Qty 3 x 1 417 005 286	←	←	Qty 3 x 1 417 005 289	←	←
Calibration screw position	3	4	5	3	4	5
Pin	417 004 309	←	←	←	←	←
Engagement RPM ± 100	4100	←	←	←	←	←
Maximum RPM ± 100	7900	←	←	←	←	←

### DRIVEN PULLEY

Altitude Clutching	Sea Level	600 m 2000 ft	1200 m 4000 ft	1800 m 6000 ft	2000 m 8000 ft	3000 m 10000 ft
Spring	Beige 414 558 900	←	←	←	←	←
Spring tension	Kg ± 0.7 lb ± 1.5	7.0 15.4	←	←	←	←
Cam angle	° (degrees)	50 417 126 343	←	←	←	←

**NOTE:** Arrows in the charts indicate that the preceding information is repeated.

**Additional Information:** Unscrew Rave Valve adjuster screws approximately three (3) turns at and above 2400 m/8000 ft.

**Recommendation:** (Formula Z 583) at and above 2400 m/8000 ft **or** in deep snow;  
chaincase ratio: 23/43 with 72 links chain, (P/N 412 106 700),  
sprocket 23 teeth, large, (P/N 504 085 400).

# 1999-FORMULA Z 583/FORMULA DLX 583

## ▼ CAUTION

These adjustments are guidelines only. Specific adjustments vary with temperature, altitude and snow conditions. Always observe spark plug condition for proper jetting.

### CARBURATION (Formula Z 583)

Altitude		Sea Level	600 m 2000 ft	1200 m 4000 ft	1800 m 6000 ft	2400 m 8000 ft	3000 m 10000 ft	Qty
Calibration								
Main jet		280 260	260 240	230 210	210 190	190 170	170 150	PTO MAG
Jet needle		7ECY1	←	←	←	←	←	2
Needle position		3	←	←	2	←	←	—
Slide cut-away		2.5	←	←	←	←	←	2
Pilot jet		60	←	←	←	←	←	2
Air screw		2.0	←	←	←	1.75	1.5	—
Valve seat		1.5	←	←	←	←	←	2
Needle jet		AA-2 (224)	←	←	AA-0 (224)	←	←	2
Float level	mm	18.1	←	←	←	←	←	—
Idle	RPM ± 200	1800	←	←	←	←	←	—
Idle throttle valve position	mm	2.0	2.10	2.20	2.60	2.70	2.80	—

### MAIN JET CHART (Formula Z 583)

Altitude		Sea Level	600 m 2000 ft	1200 m 4000 ft	1800 m 6000 ft	2400 m 8000 ft	3000 m 10000 ft	
Temperature								
- 40°C - 40°F		310 290	280 260	250 230	230 210	210 190	190 170	PTO MAG
- 30°C - 20°F		290 270	270 250	240 220	220 200	200 180	180 160	PTO MAG
<b>- 20°C - 4°F</b>		<b>280 260</b>	<b>260 240</b>	<b>230 210</b>	<b>210 190</b>	<b>190 170</b>	<b>170 150</b>	<b>PTO MAG</b>
- 10°C 14°F		270 250	250 230	220 200	200 180	180 165	165 145	PTO MAG
0°C 32°F		250 230	240 220	210 195	195 175	175 155	155 140	PTO MAG
10°C 50°F		240 220	230 210	200 185	185 165	170 150	155 135	PTO MAG
20°C 70°F		230 210	220 190	195 175	175 160	160 145	145 130	PTO MAG

## CARBURATION (Formula DLX 583)

Altitude		Sea Level	600 m 2000 ft	1200 m 4000 ft	1800 m 6000 ft	2400 m 8000 ft	3000 m 10000 ft	Qty
Calibration								
Main jet		270 260	250 240	230 220	210 200	195 185	180 170	PTO MAG
Jet needle		6DEY4	←	←	←	←	←	2
Needle position		2	←	←	1	←	←	—
Slide cut-away		2.5	←	←	←	←	←	2
Pilot jet		50	←	←	←	←	←	2
Air screw		2.0	1.75	1.5	←	←	←	—
Valve seat		1.5	←	←	←	←	←	2
Needle jet		P-7 (480)	←	←	P-5 (480)	←	P-4 (480)	2
Float level	mm	18.1	←	←	←	←	←	—
Idle	RPM ± 200	1800	←	←	←	←	←	—
Idle throttle valve position	mm	2.0	2.1	2.2	2.3	2.4	2.5	—

## MAIN JET CHART (Formula DLX 583)

Altitude		Sea Level	600 m 2000 ft	1200 m 4000 ft	1800 m 6000 ft	2400 m 8000 ft	3000 m 10000 ft	
Temperature								
- 40°C - 40°F		290 280	270 260	250 240	230 220	210 200	195 185	PTO MAG
- 30°C - 20°F		280 270	260 250	240 230	220 210	200 195	185 175	PTO MAG
<b>- 20°C - 4°F</b>		<b>270 260</b>	<b>250 240</b>	<b>230 220</b>	<b>210 200</b>	<b>195 185</b>	<b>175 170</b>	<b>PTO MAG</b>
- 10°C 14°F		260 250	240 230	220 210	200 195	180 170	155 150	PTO MAG
0°C 32°F		240 230	230 220	210 200	195 185	170 165	150 145	PTO MAG
10°C 50°F		230 220	220 210	200 195	185 180	165 160	145 140	PTO MAG
20°C 70°F		220 210	210 200	195 185	180 170	160 150	140 130	PTO MAG

**NOTE:** Arrows in the charts indicate that the preceding information is repeated.



 **WARNING**

For safety reasons, this kit must be installed by an authorized Bombardier snowmobile dealer. Should removal of a locking device be required when undergoing disassembly/assembly, always replace with a new one. This instruction sheet should be given to the purchaser. This kit is designed for specific models. It is not recommended for vehicles other than those for which it was sold.

 **CAUTION**

The following modifications and adjustments apply only for altitudes above 600 m (2000 ft).

NOTE: Installation time is approximately 1.5 hours.

## MODIFICATIONS AND ADJUSTMENTS

The transmission and carburation charts list all parts as well as modifications and adjustments needed for altitude and/or temperature changes.

*High Altitude Technical Data* sheets (P/N 484 300 003) containing technical information pertaining to carburetor jetting, transmission calibration, conversion charts and more, are available. They cover all models for the last 5 years. A convenient binder (P/N 484 054 500) can be ordered to organize the set.

## CARBURETOR JETTING

Stock vehicle jetting and the main jets included in this kit are prescribed for a temperature of - 20°C (- 4°F), as indicated by **bold face type** on the main jet chart. Snowmobile utilization above or below this temperature requires a different jetting. In that case, find the required main jet size in "Carburation" chart and order it according to the Bombardier P/N (part numbers) given in "Main Jet" P/N chart that can be found in the previously mentioned *High Altitude Technical Data* sheets.

# PARTS TO BE INSTALLED

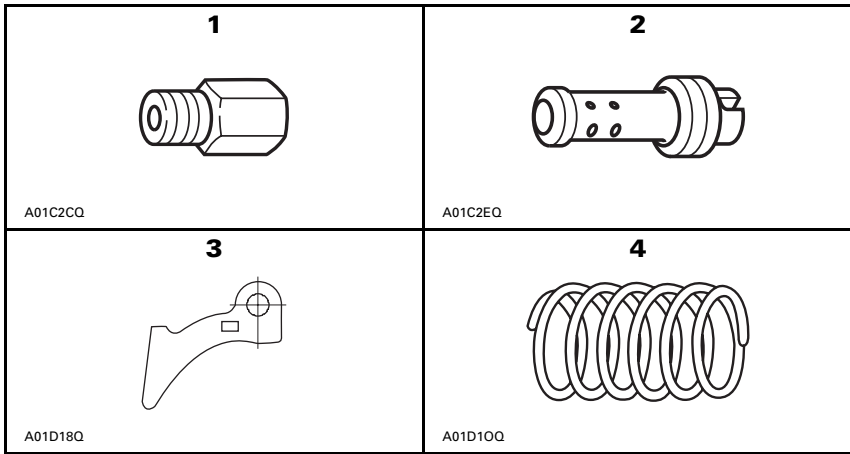

- |    |             |           |            |     |
|----|-------------|-----------|------------|-----|
| 1. | 404 100 600 | Main jet  | 260        | (1) |
|    | 404 100 200 | Main jet  | 240        | (1) |
|    | 404 111 200 | Main jet  | 220        | (1) |
|    | 404 119 100 | Main jet  | 210        | (1) |
|    | 404 112 300 | Main jet  | 200        | (1) |
|    | 404 112 200 | Main jet  | 180        | (1) |
| 2. | 404 113 900 | Pilot jet | 55         | (2) |
| 3. | 417 005 281 | Ramp      | 281        | (3) |
| 4. | 414 768 200 | Spring    | Green/Blue | (1) |

# 1999-FORMULA Z 500/DELUXE 500 LC

## HIGH ALTITUDE KIT (P/N 861 767 300)

### DRIVE PULLEY (Formula DLX 500 LC)

Altitude		Sea Level	600 m 2000 ft	1200 m 4000 ft	1800 m 6000 ft	2400 m 8000 ft	3000 m 10000 ft
Clutching							
Spring		Violet/Blue 415 034 900	←	←	←	←	←
Ramp		Qty 3 x 1 417 005 286	←	←	Qty 3 x 1 417 005 281	←	←
Calibration screw position		2	3	4	4	5	6
Pin		Qty 3 x 1 417 004 309	←	←	←	←	←
Engagement RPM ± 100		3800	←	←	←	←	←
Maximum RPM ± 100		7800	←	←	←	←	←

### DRIVE PULLEY (Formula Z 500)

Altitude		Sea Level	600 m 2000 ft	1200 m 4000 ft	1800 m 6000 ft	2400 m 8000 ft	3000 m 10000 ft
Clutching							
Spring		Violet/Yellow 415 015 300	←	←	Green/Blue 414 768 200	←	←
Ramp		Qty 3 x 1 417 005 281	←	←	←	←	←
Calibration screw position		2	3	4	4	5	6
Pin		Qty 3 x 1 417 004 309	←	←	←	←	←
Engagement RPM ± 100		4100	←	←	4300	←	←
Maximum RPM ± 100		7800	←	←	←	←	←

### DRIVEN PULLEY

Altitude		Sea Level	600 m 2000 ft	1200 m 4000 ft	1800 m 6000 ft	2000 m 8000 ft	3000 m 10000 ft
Clutching							
Spring		Beige 414 558 900	←	←	←	←	←
Spring tension	Kg ± 0.7 lb ± 1.5	7.0 15.4	←	←	←	←	←
Cam angle	° (degrees)	50° 417 126 343	←	←	←	←	←

**NOTE:** Arrows in the charts indicate that the preceding information is repeated.



# 1999-FORMULA Z 500/DELUXE 500 LC

## ▼ CAUTION

These adjustments are guidelines only. Specific adjustments vary with temperature, altitude and snow conditions. Always observe spark plug condition for proper jetting.

### CARBURATION

Altitude		Sea Level	600 m 2000 ft	1200 m 4000 ft	1800 m 6000 ft	2400 m 8000 ft	3000 m 10000 ft	Qty
Calibration								
Main jet		300 280	280 260	260 240	240 210	220 200	200 180	PTO MAG
Jet needle		6DGY9	←	←	←	←	←	2
Needle position		2	←	←	1	←	←	—
Slide cut-away		2.5	←	←	←	←	←	2
Pilot jet		50	←	←	55	←	←	2
Air screw		2.00	←	←	2.50	←	←	—
Valve seat		1.5	←	←	←	←	←	2
Needle jet		Q-3 (480)	←	←	←	←	←	2
Float level	mm	18.1	←	←	←	←	←	—
Idle	RPM ± 200	1800	←	←	←	←	←	—
Idle throttle valve position	mm	1.80	1.90	2.10	2.30	2.40	2.50	—

### MAIN JET CHART

Altitude		Sea Level	600 m 2000 ft	1200 m 4000 ft	1800 m 6000 ft	2400 m 8000 ft	3000 m 10000 ft	
Temperature								
- 40°C - 40°F		320 300	300 280	280 260	260 230	240 220	220 200	PTO MAG
- 30°C - 20°F		310 290	290 270	270 250	250 220	230 210	210 190	PTO MAG
<b>- 20°C - 4°F</b>		<b>300 280</b>	<b>280 260</b>	<b>260 240</b>	<b>240 210</b>	<b>220 200</b>	<b>200 180</b>	<b>PTO MAG</b>
- 10°C 14°F		290 270	270 250	250 230	230 200	210 190	190 170	PTO MAG
0°C 32°F		280 260	260 240	240 220	220 190	200 180	180 160	PTO MAG
10°C 50°F		270 250	250 230	230 210	210 180	190 170	170 150	PTO MAG
20°C 70°F		260 240	240 220	220 200	200 170	180 160	160 140	PTO MAG

NOTE: Arrows in the charts indicate that the preceding information is repeated.



## **WARNING**

For safety reasons, this kit must be installed by an authorized Bombardier snowmobile dealer. Should removal of a locking device be required when undergoing disassembly/assembly, always replace with a new one. This instruction sheet should be given to the purchaser. This kit is designed for specific models. It is not recommended for vehicles other than those for which it was sold.



## **CAUTION**

The following modifications and adjustments apply only for altitudes above 600 m (2000 ft).

**NOTE:** Installation time is approximately 1.5 hours.

## **MODIFICATIONS AND ADJUSTMENTS**

The transmission and carburation charts list all parts as well as modifications and adjustments needed for altitude and/or temperature changes.

*High Altitude Technical Data* sheets (P/N 484 300 003) containing technical information pertaining to carburetor jetting, transmission calibration, conversion charts and more, are available. They cover all models for the last 5 years. A convenient binder (P/N 484 054 500) can be ordered to organize the set.

## **CARBURETOR JETTING**

Stock vehicle jetting and the main jets included in this kit are prescribed for a temperature of - 20°C (- 4°F), as indicated by **bold face type** on the main jet chart. Snowmobile utilization above or below this temperature requires a different jetting. In that case, find the required main jet size in "Carburation" chart and order it according to the Bombardier P/N (part numbers) given in "Main Jet" P/N chart that can be found in the previously mentioned *High Altitude Technical Data* sheets.

# PARTS TO BE INSTALLED

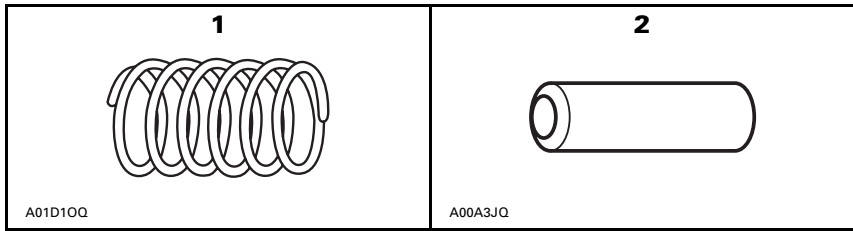

- |    |             |        |            |     |
|----|-------------|--------|------------|-----|
| 1. | 414 756 900 | Spring | Green/Pink | (1) |
| 2. | 417 004 309 | Pin    |            | (3) |

# 1999-MX Z 670 HO/HO T.H.

## HIGH ALTITUDE KIT (P/N 861 767 600)

### DRIVE PULLEY

Altitude Clutching		Sea Level	600 m 2000 ft	1200 m 4000 ft	1800 m 6000 ft	2400 m 8000 ft	3000 m 10000 ft
Spring		Green/Blue 414 768 200	←	←	← Green/Pink 414 756 900	←	←
Ramp		415 005 297	←	←	←	←	←
Calibration screw position		2	3	4	4	5	6
Pin		Qty 3 x 1 417 004 308	←	←	Qty 3 x 1 417 004 309	←	←
Engagement RPM ± 100		4200	←	←	4500	←	←
Maximum RPM ± 100		8000	←	←	←	←	←

### DRIVEN PULLEY

Altitude Clutching		Sea Level	600 m 2000 ft	1200 m 4000 ft	1800 m 6000 ft	2000 m 8000 ft	3000 m 10000 ft
Spring		Beige 414 558 900	←	←	←	←	←
Spring tension	Kg ± 0.7 lb ± 1.5	7.0 15.4	←	←	←	←	←
Cam angle	° (degrees)	53 - 47 417 126 380	←	←	←	←	←

**NOTE:** Arrows in the charts indicate that the preceding information is repeated.

**Recommendation:** At and above 2400 m/8000 ft **or** in deep snow; chaincase ratio: 23/43 with 72 links chain, (P/N 412 106 700), sprocket 23 teeth, large, (P/N 504 085 400).

# 1999-MX Z 670 HO/HO T.H.

## ▼ CAUTION

These adjustments are guidelines only. Specific adjustments vary with temperature, altitude and snow conditions. Always observe spark plug condition for proper jetting.

### CARBURATION

Altitude		Sea Level	600 m 2000 ft	1200 m 4000 ft	1800 m 6000 ft	2400 m 8000 ft	3000 m 10000 ft	Qty
Calibration								
Main jet		340 310	←	←	←	←	←	PTO MAG
Jet needle		7ECY1	←	←	←	←	←	2
Needle position		3	←	←	←	←	←	—
Slide cut-away		2.5	←	←	←	←	←	2
Pilot jet		55	←	←	←	←	←	2
Air screw		1.75	←	←	←	←	←	—
Valve seat		1.5	←	←	←	←	←	—
Needle jet		AA-4 (224)	←	←	←	←	←	2
Float level	mm	22.9	←	←	←	←	←	—
Idle	RPM ± 200	1700	←	←	←	←	←	—
Idle throttle valve position	mm	1.9	2.1	2.2	2.3	2.4	2.5	—

### MAIN JET CHART

Altitude		Sea Level	600 m 2000 ft	1200 m 4000 ft	1800 m 6000 ft	2400 m 8000 ft	3000 m 10000 ft	
Temperature								
- 40°C - 40°F		360 330	←	←	←	←	←	PTO MAG
- 30°C - 20°F		350 320	←	←	←	←	←	PTO MAG
<b>- 20°C - 4°F</b>		<b>340 310</b>	←	←	←	←	←	<b>PTO MAG</b>
- 10°C 14°F		340 310	←	←	←	←	←	PTO MAG
0°C 32°F		340 310	←	←	←	←	←	PTO MAG
10°C 50°F		340 310	←	←	←	←	←	PTO MAG
20°C 70°F		340 310	←	←	←	←	←	PTO MAG

**NOTE:** Arrows in the charts indicate that the preceding information is repeated.



## **WARNING**

For safety reasons, this kit must be installed by an authorized Bombardier snowmobile dealer. Should removal of a locking device be required when undergoing disassembly/assembly, always replace with a new one. This instruction sheet should be given to the purchaser. This kit is designed for specific models. It is not recommended for vehicles other than those for which it was sold.



## **CAUTION**

The following modifications and adjustments apply only for altitudes above 600 m (2 000 ft).

**NOTE:** Installation time is approximately 1.5 hours.

## **MODIFICATIONS AND ADJUSTMENTS**

The transmission and carburation charts list all parts as well as modifications and adjustments needed for altitude and/or temperature changes.

*High Altitude Technical Data* sheets (P/N 484 300 003) containing technical information pertaining to carburetor jetting, transmission calibration, conversion charts and more, are available. They cover all models for the last 5 years. A convenient binder (P/N 484 054 500) can be ordered to organize the set.

## **CARBURETOR JETTING**

Stock vehicle jetting and the main jets included in this kit are prescribed for a temperature of - 20°C (- 4°F), as indicated by **bold face type** on the main jet chart. Snowmobile utilization above or below this temperature requires a different jetting. In that case, find the required main jet size in "Carburation" chart and order it according to the Bombardier P/N (part numbers) given in "Main Jet" P/N chart that can be found in the previously mentioned *High Altitude Technical Data* sheets.

# PARTS TO BE INSTALLED

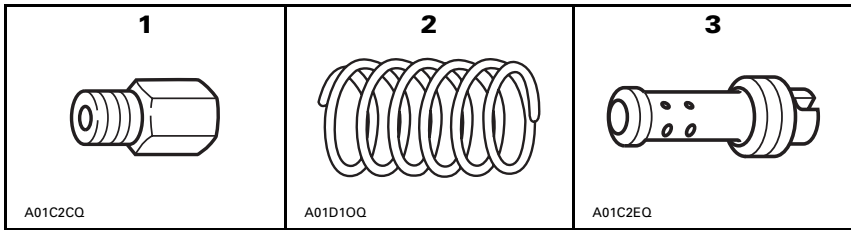

- |    |             |           |            |     |     |
|----|-------------|-----------|------------|-----|-----|
| 1. | 404 100 600 | Main jet  | 260        | (1) |     |
|    | 404 100 200 | Main jet  | 240        | (1) |     |
|    | 404 111 200 | Main jet  | 220        | (1) |     |
|    | 404 119 100 | Main jet  | 210        | (1) |     |
|    | 404 112 300 | Main jet  | 200        | (1) |     |
|    | 404 112 200 | Main jet  | 180        | (1) |     |
| 2. | 414 768 200 | Spring    | Green/Blue |     | (1) |
| 3. | 404 109 400 | Pilot jet | 45         |     | (2) |

# 1999-MX-Z 500

## HIGH ALTITUDE KIT (P/N 861 767 800)

### DRIVE PULLEY

Altitude Clutching		Sea Level	600 m 2000 ft	1200 m 4000 ft	1800 m 6000 ft	2400 m 8000 ft	3000 m 10000 ft
Spring		Violet/Yellow 415 015 300	←	←	Green/Blue 414 768 200	←	←
Ramp		417 005 281	←	←	←	←	←
Calibration screw position		2	3	4	4	5	6
Pin		417 004 309	←	←	←	←	←
Engagement RPM ± 100		4100	←	←	4300	←	←
Maximum RPM ± 100		7800	←	←	←	←	←

### DRIVEN PULLEY

Altitude Clutching		Sea Level	600 m 2000 ft	1200 m 4000 ft	1800 m 6000 ft	2000 m 8000 ft	3000 m 10000 ft
Spring		Beige 415 558 900	←	←	←	←	←
Spring tension	Kg ± 0.7 lb ± 1.5	7.0 15.4	←	←	←	←	←
Cam angle	° (degrees)	50° 417 126 343	←	←	←	←	←

**NOTE:** Arrows in the charts indicate that the preceding information is repeated.



# 1999-MX-Z 500

## ▼ CAUTION

These adjustments are guidelines only. Specific adjustments vary with temperature, altitude and snow conditions. Always observe spark plug condition for proper jetting.

### CARBURATION

Altitude		Sea Level	600 m 2000 ft	1200 m 4000 ft	1800 m 6000 ft	2400 m 8000 ft	3000 m 10000 ft	Qty
Calibration								
Main jet		300 280	280 260	260 240	240 210	220 200	200 180	PTO MAG
Jet needle		6DGY9	←	←	←	←	←	2
Needle position		3	←	←	2	←	←	—
Slide cut-away		2.5	←	←	←	←	←	2
Pilot jet		50	←	←	45	←	←	2
Air screw		2.5	←	←	3.0	←	←	—
Valve seat		1.5	←	←	←	←	←	2
Needle jet		Q-4 (480)	←	←	←	←	←	2
Float level	mm	18.1	←	←	←	←	←	—
Idle	RPM ± 200	1800	←	←	←	←	←	—
Idle throttle valve position	mm	1.8	←	2.1	2.2	2.3	2.4	—

### MAIN JET CHART

Altitude		Sea Level	600 m 2000 ft	1200 m 4000 ft	1800 m 6000 ft	2400 m 8000 ft	3000 m 10000 ft	
Temperature								
- 40°C		320	300	280	260	240	220	PTO MAG
- 40°F		300	280	260	230	220	200	
- 30°C		310	290	270	250	230	210	PTO MAG
- 20°F		290	270	250	220	210	190	
<b>- 20°C</b>		<b>300</b>	<b>280</b>	<b>260</b>	<b>240</b>	<b>220</b>	<b>200</b>	<b>PTO MAG</b>
<b>- 4°F</b>		<b>280</b>	<b>260</b>	<b>240</b>	<b>210</b>	<b>200</b>	<b>180</b>	
- 10°C		290	270	250	230	210	190	PTO MAG
14°F		270	250	230	200	190	170	
0°C		280	260	240	220	200	180	PTO MAG
32°F		260	240	220	190	180	160	
10°C		270	250	230	210	190	170	PTO MAG
50°F		250	230	210	180	170	150	
20°C		260	240	220	200	180	160	PTO MAG
70°F		240	220	200	170	160	140	

**NOTE:** Arrows in the charts indicate that the preceding information is repeated.



## **WARNING**

For safety reasons, this kit must be installed by an authorized Bombardier snowmobile dealer. Should removal of a locking device be required when undergoing disassembly/assembly, always replace with a new one. This instruction sheet should be given to the purchaser. This kit is designed for specific models. It is not recommended for vehicles other than those for which it was sold.



## **CAUTION**

The following modifications and adjustments apply only for altitudes above 600 m (2 000 ft).

**NOTE:** Installation time is approximately 1.5 hours.

## **MODIFICATIONS AND ADJUSTMENTS**

The transmission and carburation charts list all parts as well as modifications and adjustments needed for altitude and/or temperature changes.

*High Altitude Technical Data* sheets (P/N 484 300 003) containing technical information pertaining to carburetor jetting, transmission calibration, conversion charts and more, are available. They cover all models for the last 5 years. A convenient binder (P/N 484 054 500) can be ordered to organize the set.

## **CARBURETOR JETTING**

Stock vehicle jetting and the main jets included in this kit are prescribed for a temperature of -20°C (-4°F), as indicated by **bold face type** on the main jet chart. Snowmobile utilization above or below this temperature requires a different jetting. In that case, find the required main jet size in "Carburation" chart and order it according to the Bombardier P/N (part numbers) given in "Main Jet" P/N chart that can be found in the previously mentioned *High Altitude Technical Data* sheets.

# PARTS TO BE INSTALLED

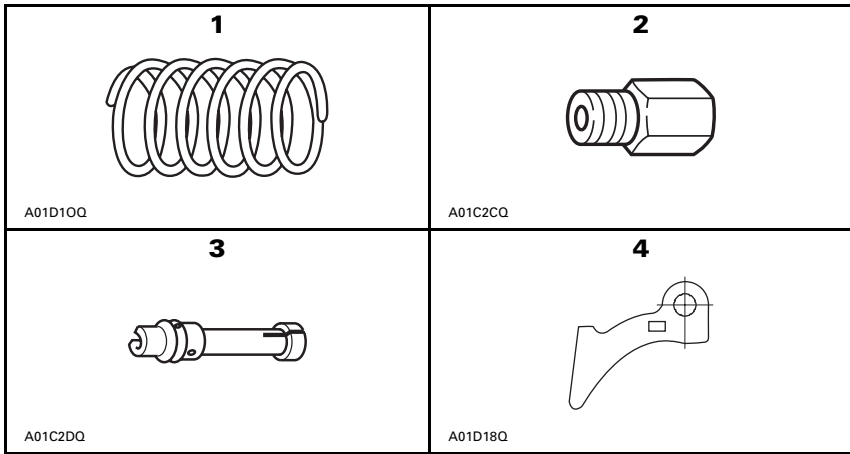

- |    |             |            |             |     |
|----|-------------|------------|-------------|-----|
| 1. | 415 034 900 | Spring     | Violet/Blue | (1) |
| 2. | 404 100 300 | Main jet   | 250         | (1) |
|    | 404 100 200 | Main jet   | 240         | (1) |
|    | 404 118 900 | Main jet   | 230         | (1) |
|    | 404 111 200 | Main jet   | 220         | (1) |
|    | 404 119 100 | Main jet   | 210         | (1) |
|    | 404 112 300 | Main jet   | 200         | (1) |
|    | 404 119 400 | Main jet   | 195         | (1) |
|    | 404 119 500 | Main jet   | 185         | (1) |
|    | 404 112 200 | Main jet   | 180         | (1) |
|    | 404 123 800 | Main jet   | 170         | (1) |
| 3. | 404 157 300 | Needle jet | P-5 (480)   | (2) |
|    | 404 131 500 | Needle jet | P-4 (480)   | (2) |
| 4. | 417 005 289 | Ramp       | 289         | (3) |

# 1999-GRAND TOURING 583

## HIGH ALTITUDE KIT (P/N 861 768 200)

### DRIVE PULLEY

Altitude Clutching		Sea Level	600 m 2000 ft	1200 m 4000 ft	1800 m 6000 ft	2400 m 8000 ft	3000 m 10000 ft	Qty
Spring		Red/Orange 415 015 200	←	←	Violet/Blue 415 034 900	←	←	1
Ramp		Qty 3 x 1 417 005 285	←	←	Qty 3 x 1 417 005 289	←	←	3
Calibration screw position		3	4	5	4	5	6	—
Pin		417 004 309	←	←	←	←	←	3
Engagement RPM ± 100		3100	←	←	4200	←	←	—
Maximum RPM ± 100		7900	←	←	←	←	←	—

### DRIVEN PULLEY

Altitude Clutching		Sea Level	600 m 2000 ft	1200 m 4000 ft	1800 m 6000 ft	2000 m 8000 ft	3000 m 10000 ft
Spring		Beige 414 558 900	←	←	←	←	←
Spring tension	Kg ± 0.7 lb ± 1.5	7.0 15.4	←	←	←	←	←
Cam angle	° (degrees)	47 417 126 337	←	←	←	←	←

**NOTE:** Arrows in the charts indicate that the preceding information is repeated.

**Additional Information:** Unscrew Rave Valve adjuster screws approximately three (3) turns at 2400 m/8000 ft.

# 1999-GRAND TOURING 583



## CAUTION

These adjustments are guidelines only. Specific adjustments vary with temperature, altitude and snow conditions. Always observe spark plug condition for proper jetting.

### CARBURATION

Altitude		Sea Level	600 m 2000 ft	1200 m 4000 ft	1800 m 6000 ft	2400 m 8000 ft	3000 m 10000 ft	Qty
Calibration		270 260	250 240	230 220	210 200	195 185	180 170	PTO MAG
Main jet		270 260	250 240	230 220	210 200	195 185	180 170	PTO MAG
Jet needle		6DEY4	←	←	←	←	←	2
Needle position		2	←	←	1	←	←	—
Slide cut-away		2.5	←	←	←	←	←	2
Pilot jet		50	←	←	←	←	←	2
Air screw		2.0	1.75	1.5	←	←	←	—
Valve seat		1.5	←	←	←	←	←	2
Needle jet		P-7 (480)	←	←	P-5 (480)	←	P-4 (480)	2
Float level	mm	18.1	←	←	←	←	←	—
Idle	RPM ± 200	1800	←	←	←	←	←	—
Idle throttle valve position	mm	2.00	2.10	2.20	2.30	2.40	2.50	—

### MAIN JET CHART

Altitude		Sea Level	600 m 2000 ft	1200 m 4000 ft	1800 m 6000 ft	2400 m 8000 ft	3000 m 10000 ft	
Temperature								
- 40°C		290	270	250	230	210	195	PTO
- 40°F		280	260	240	220	200	185	MAG
- 30°C		280	260	240	220	200	185	PTO
- 20°F		270	250	230	210	195	175	MAG
- 20°C		<b>270</b>	<b>250</b>	<b>230</b>	<b>210</b>	<b>195</b>	<b>175</b>	<b>PTO</b>
- 4°F		<b>260</b>	<b>240</b>	<b>220</b>	<b>200</b>	<b>185</b>	<b>170</b>	<b>MAG</b>
- 10°C		260	240	220	200	180	155	PTO
14°F		250	230	210	195	170	150	MAG
0°C		250	230	210	195	170	150	PTO
32°F		240	220	200	185	165	145	MAG
10°C		240	220	200	185	165	145	PTO
50°F		230	210	195	180	160	140	MAG
20°C		230	210	195	180	160	140	PTO
70°F		220	200	185	170	150	130	MAG

NOTE: Arrows in the charts indicate that the preceding information is repeated.



## **WARNING**

For safety reasons, this kit must be installed by an authorized Bombardier snowmobile dealer. Should removal of a locking device be required when undergoing disassembly/assembly, always replace with a new one. This instruction sheet should be given to the purchaser. This kit is designed for specific models. It is not recommended for vehicles other than those for which it was sold.



## **CAUTION**

The following modifications and adjustments apply only for altitudes above 600 m (2 000 ft).

**NOTE:** Installation time is approximately 1.5 hours.

## **MODIFICATIONS AND ADJUSTMENTS**

The transmission and carburation charts list all parts as well as modifications and adjustments needed for altitude and/or temperature changes.

*High Altitude Technical Data* sheets (P/N 484 300 003) containing technical information pertaining to carburetor jetting, transmission calibration, conversion charts and more, are available. They cover all models for the last 5 years. A convenient binder (P/N 484 054 500) can be ordered to organize the set.

## **CARBURETOR JETTING**

Stock vehicle jetting and the main jets included in this kit are prescribed for a temperature of -20°C (-4°F), as indicated by **bold face type** on the main jet chart. Snowmobile utilization above or below this temperature requires a different jetting. In that case, find the required main jet size in "Carburation" chart and order it according to the Bombardier P/N (part numbers) given in "Main Jet" P/N chart that can be found in the previously mentioned *High Altitude Technical Data* sheets.

# PARTS TO BE INSTALLED

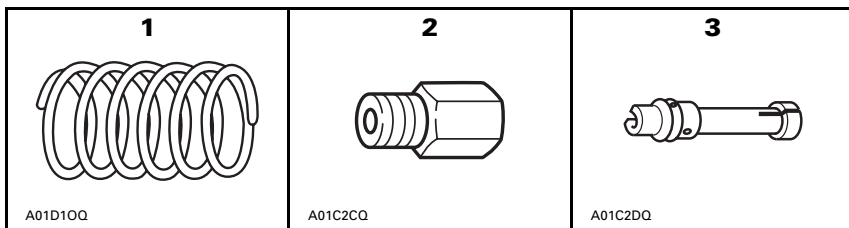

- |    |             |            |           |     |
|----|-------------|------------|-----------|-----|
| 1. | 414 689 400 | Spring     | Blue/Blue | (1) |
| 2. | 404 100 600 | Main Jet   | 260       | (1) |
|    | 404 100 200 | Main Jet   | 240       | (1) |
|    | 404 111 200 | Main Jet   | 220       | (1) |
|    | 404 119 100 | Main Jet   | 210       | (1) |
|    | 404 112 300 | Main Jet   | 200       | (1) |
|    | 404 112 200 | Main Jet   | 180       | (1) |
| 3. | 404 113 900 | Needle Jet | Q-3 (480) | (2) |

# 1999-GRAND TOURING 500

## HIGH ALTITUDE KIT (P/N 861 768 300)

### DRIVE PULLEY

Altitude Clutching		Sea Level	600 m 2000 ft	1200 m 4000 ft	1800 m 6000 ft	2400 m 8000 ft	3000 m 10000 ft
Spring		Blue/Green 414 817 700	←	←	Blue/Blue 414 689 400	←	←
Ramp		417 005 228	←	←	←	←	←
Calibration screw position		2	3	4	4	5	6
Pin		417 004 309	←	←	←	←	←
Engagement RPM ± 100		3600	←	←	←	←	←
Maximum RPM ± 100		7800	←	←	←	←	←

### DRIVEN PULLEY

Altitude Clutching		Sea Level	600 m 2000 ft	1200 m 4000 ft	1800 m 6000 ft	2000 m 8000 ft	3000 m 10000 ft
Spring		Beige 414 558 900	←	←	←	←	←
Spring tension	Kg ± 0.7 lb ± 1.5	7.0 15.4	←	←	←	←	←
Cam angle	° (degrees)	44 417 126 333	←	←	←	←	←

**NOTE:** Arrows in the charts indicate that the preceding information is repeated.



# 1999-GRAND TOURING 500

## ▼ CAUTION

These adjustments are guidelines only. Specific adjustments vary with temperature, altitude and snow conditions. Always observe spark plug condition for proper jetting.

### CARBURATION

Altitude		Sea Level	600 m 2000 ft	1200 m 4000 ft	1800 m 6000 ft	2400 m 8000 ft	3000 m 10000 ft	Qty
Calibration								
Main jet		300 280	280 260	260 240	240 210	220 200	200 180	PTO MAG
Jet needle		6DGY9	←	←	←	←	←	2
Needle position		2	←	←	1	←	←	—
Slide cut-away		2.5	←	←	←	←	←	2
Pilot jet		50	←	←	55	←	←	2
Air screw		2.0	←	←	2.50	←	←	—
Valve seat		1.5	←	←	←	←	←	2
Needle jet		Q-3 (480)	←	←	←	←	←	2
Float level	mm	18.1	←	←	←	←	←	—
Idle	RPM ± 200	1800	←	←	←	←	←	—
Idle throttle valve position	mm	1.80	1.90	2.10	2.30	2.40	2.50	—

### MAIN JET CHART

Altitude		Sea Level	600 m 2000 ft	1200 m 4000 ft	1800 m 6000 ft	2400 m 8000 ft	3000 m 10000 ft	
Temperature								
- 40°C		320	300	280	260	240	220	PTO MAG
- 40°F		300	280	260	230	220	200	
- 30°C		310	290	270	250	230	210	PTO MAG
- 20°F		290	270	250	220	210	190	
- 20°C		300	280	260	<b>240</b>	<b>220</b>	<b>200</b>	<b>PTO MAG</b>
- 4°F		280	260	240	<b>210</b>	<b>200</b>	<b>180</b>	
- 10°C		290	270	250	230	210	190	PTO MAG
14°F		270	250	230	200	190	170	
0°C		280	260	240	220	200	180	PTO MAG
32°F		260	240	220	190	180	160	
10°C		270	250	230	210	190	170	PTO MAG
50°F		250	230	210	180	170	150	
20°C		260	240	220	200	180	160	PTO MAG
70°F		240	220	200	170	160	140	

**NOTE:** Arrows in the charts indicate that the preceding information is repeated.



 **WARNING**

For safety reasons, this kit must be installed by an authorized Bombardier snowmobile dealer. Should removal of a locking device be required when undergoing disassembly/assembly, always replace with a new one. This instruction sheet should be given to the purchaser. This kit is designed for specific models. It is not recommended for vehicles other than those for which it was sold.

 **CAUTION**

The following modifications and adjustments apply only for altitudes above 600 m (2000 ft).

NOTE: Installation time is approximately 1.5 hours.

## MODIFICATIONS AND ADJUSTMENTS

The transmission and carburation charts list all parts as well as modifications and adjustments needed for altitude and/or temperature changes.

*High Altitude Technical Data* sheets (P/N 484 300 003) containing technical information pertaining to carburetor jetting, transmission calibration, conversion charts and more, are available. They cover all models for the last 5 years. A convenient binder (P/N 484 054 500) can be ordered to organize the set.

## CARBURETOR JETTING

Stock vehicle jetting and the main jets included in this kit are prescribed for a temperature of - 20°C (- 4°F), as indicated by **bold face type** on the main jet chart. Snowmobile utilization above or below this temperature requires a different jetting. In that case, find the required main jet size in "Carburation" chart and order it according to the Bombardier P/N (part numbers) given in "Main Jet" P/N chart that can be found in the previously mentioned *High Altitude Technical Data* sheets.

# PARTS TO BE INSTALLED

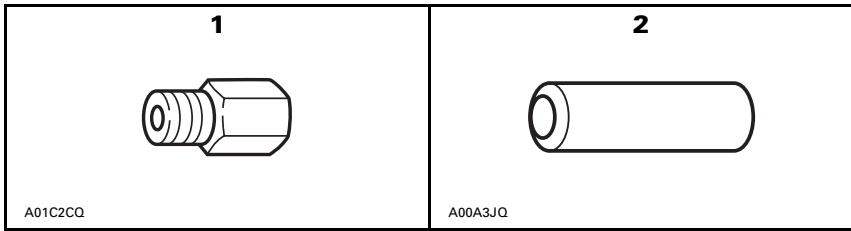

- |    |             |          |     |  |     |
|----|-------------|----------|-----|--|-----|
| 1. | 404 100 500 | Main jet | 280 |  | (3) |
|    | 404 100 600 | Main jet | 260 |  | (3) |
|    | 404 100 200 | Main jet | 240 |  | (3) |
|    | 404 111 200 | Main jet | 220 |  | (3) |
|    | 404 112 300 | Main jet | 200 |  | (3) |
| 2. | 417 004 309 | Pin      |     |  | (3) |

# 1999-MACH 1/1 R

## HIGH ALTITUDE KIT (P/N 861 766 700)

### DRIVE PULLEY

Altitude Clutching	Sea Level	600 m 2000 ft	1200 m 4000 ft	1800 m 6000 ft	2400 m 8000 ft	3000 m 10000 ft
Spring	Green/Violet 414 762 800	←	←	←	←	←
Ramp	Qty 3 x 1 417 005 286	←	←	←	←	←
Calibration screw position	3	3	4	4	5	6
Pin	Qty 3 x 1 417 004 308	←	←	Qty 3 x 1 417 004 309	←	←
Engagement RPM ± 100	4200	←	←	4500	←	←
Maximum RPM ± 100	8300	←	←	←	←	←

### DRIVEN PULLEY (MACH 1)

Altitude Clutching	Sea Level	600 m 2000 ft	1200 m 4000 ft	1800 m 6000 ft	2000 m 8000 ft	3000 m 10000 ft
Spring	Beige 414 558 900	←	←	←	←	←
Spring tension	Kg ± 0.7 lb ± 1.5	7.0 15.4	←	←	←	←
Cam angle	° (degrees)	53-44 417 126 387	←	←	←	←

### DRIVEN PULLEY (MACH 1 R)

Altitude Clutching	Sea Level	600 m 2000 ft	1200 m 4000 ft	1800 m 6000 ft	2000 m 8000 ft	3000 m 10000 ft
Spring	Violet 414 978 300	←	←	←	←	←
Spring tension	Kg ± 0.7 lb ± 1.5	0.00 Position 0	←	←	←	←
Cam angle	° (degrees)	47-44 417 126 385	←	←	←	←

**NOTE:** Arrows in the charts indicate that the preceding information is repeated.

**Recommendation:** At and above 2400 m/8000 ft **or** in deep snow; chaincase ratio: 23/43, sprocket 23 teeth, large, (P/N 504 085 400).

# 1999-MACH 1/1 R



## CAUTION

These adjustments are guidelines only. Specific adjustments vary with temperature, altitude and snow conditions. Always observe spark plug condition for proper jetting.

### CARBURATION

Altitude		Sea Level	600 m 2000 ft	1200 m 4000 ft	1800 m 6000 ft	2400 m 8000 ft	3000 m 10000 ft	Qty
Main jet		300	280	260	240	220	200	3
Jet needle		8AGY1/41	←	←	←	←	←	3
Needle position		4	←	3	←	2	←	—
Slide cut-away		2.0	←	←	←	←	←	3
Pilot jet		50	←	←	←	←	←	3
Air screw		4.00	←	←	←	←	←	—
Valve seat		1.5	←	←	←	←	←	3
Needle jet		N-7 (327)	←	←	←	←	←	3
Float level	mm	21.0	←	←	←	←	←	—
Idle	RPM ± 200	1800	←	←	←	←	←	—
Idle throttle valve position	mm	1.3	1.5	←	1.4	←	1.5	—

### MAIN JET CHART

Altitude		Sea Level	600 m 2000 ft	1200 m 4000 ft	1800 m 6000 ft	2400 m 8000 ft	3000 m 10000 ft	Qty
- 40°C - 40°F		320	300	280	260	240	220	3
- 30°C - 20°F		310	290	270	250	230	210	3
<b>- 20°C - 4°F</b>		<b>300</b>	<b>280</b>	<b>260</b>	<b>240</b>	<b>220</b>	<b>200</b>	<b>3</b>
- 10°C 14°F		290	270	250	230	210	190	3
0°C 32°F		280	260	240	220	200	190	3
10°C 50°F		270	250	230	220	200	180	3
20°C 70°F		260	240	230	210	190	170	3

**NOTE:** Arrows in the charts indicate that the preceding information is repeated.



 **WARNING**

For safety reasons, this kit must be installed by an authorized Bombardier snowmobile dealer. Should removal of a locking device be required when undergoing disassembly/assembly, always replace with a new one. This instruction sheet should be given to the purchaser. This kit is designed for specific models. It is not recommended for vehicles other than those for which it was sold.

 **CAUTION**

The following modifications and adjustments apply only for altitudes above 600 m (2000 ft).

NOTE: Installation time is approximately 1.5 hours.

## MODIFICATIONS AND ADJUSTMENTS

The transmission and carburation charts list all parts as well as modifications and adjustments needed for altitude and/or temperature changes.

*High Altitude Technical Data* sheets (P/N 484 300 003) containing technical information pertaining to carburetor jetting, transmission calibration, conversion charts and more, are available. They cover all models for the last 5 years. A convenient binder (P/N 484 054 500) can be ordered to organize the set.

## CARBURETOR JETTING

Stock vehicle jetting and the main jets included in this kit are prescribed for a temperature of - 20°C (- 4°F), as indicated by **bold face type** on the main jet chart. Snowmobile utilization above or below this temperature requires a different jetting. In that case, find the required main jet size in "Carburation" chart and order it according to the Bombardier P/N (part numbers) given in "Main Jet" P/N chart that can be found in the previously mentioned *High Altitude Technical Data* sheets.

# PARTS TO BE INSTALLED

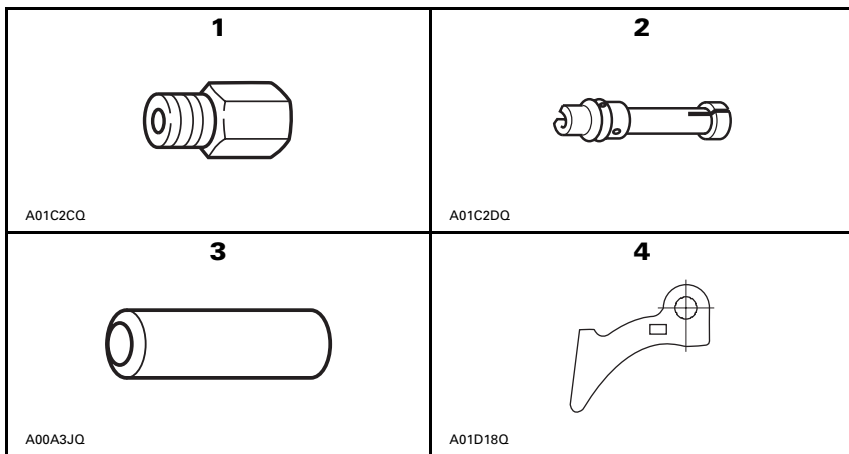

- |    |             |            |           |     |
|----|-------------|------------|-----------|-----|
| 1. | 404 100 300 | Main jet   | 250       | (3) |
|    | 404 118 900 | Main jet   | 230       | (3) |
|    | 404 119 100 | Main jet   | 210       | (3) |
|    | 404 119 000 | Main jet   | 190       | (3) |
|    | 404 123 800 | Main jet   | 170       | (3) |
| 2. | 404 161 858 | Needle jet | O-8 (286) | (3) |
| 3. | 417 004 309 | Pin        |           | (3) |
| 4. | 417 005 281 | Ramp       | 281       | (3) |

# 1999-FORMULA III 600

## HIGH ALTITUDE KIT (P/N 861 767 000)

### DRIVE PULLEY

Altitude		Sea Level	600 m 2000 ft	1200 m 4000 ft	1800 m 6000 ft	2400 m 8000 ft	3000 m 10000 ft
Clutching							
Spring		Green/Blue 414 768 200	←	←	←	←	←
Ramp		Qty 3 x 1 417 005 297	←	←	Qty 3 x 1 417 005 281	←	←
Calibration screw position		3	4	5	4	5	6
Pin		Qty 3 x 1 417 334 308	←	←	Qty 3 x 1 417 004 309	←	←
Engagement RPM ± 100		4200	←	←	4500	←	←
Maximum RPM ± 100		8400	←	←	←	←	←

### DRIVEN PULLEY

Altitude		Sea Level	600 m 2000 ft	1200 m 4000 ft	1800 m 6000 ft	2000 m 8000 ft	3000 m 10000 ft
Clutching							
Spring		Beige 414 558 900	←	←	←	←	←
Spring tension	Kg ± 0.7 lb ± 1.5	7.0 15.4	←	←	←	←	←
Cam angle	° (degrees)	50-47 417 126 339	←	←	←	←	←

**NOTE:** Arrows in the charts indicate that the preceding information is repeated.

**Recommendation:** For use at and above 2400m/8000 ft **or** in deep snow;  
chaincase ratio: 22/43 with 70 links chain, (P/N 412 106 800),  
sprocket 22 teeth, large, (P/N 504 083 500).



# 1999-FORMULA III 600

## ▼ CAUTION

These adjustments are guidelines only. Specific adjustments vary with temperature, altitude and snow conditions. Always observe spark plug condition for proper jetting.

### CARBURATION

Altitude		Sea Level	600 m 2000 ft	1200 m 4000 ft	1800 m 6000 ft	2400 m 8000 ft	3000 m 10000 ft	Qty
Calibration								
Main jet		270	250	230	210	190	170	3
Jet needle		6DEY2	←	←	←	←	←	3
Needle position		2	←	1	←	←	←	—
Slide cut-away		2.5	←	←	←	←	←	—
Pilot jet		50	←	←	←	←	←	3
Air screw		2.00	←	←	←	←	←	—
Valve seat		1.5	←	←	←	←	←	3
Needle jet		P-0 (286)	←	←	←	O-8 (286)	←	3
Float level	mm	18.1	←	←	←	←	←	—
Idle	RPM ± 200	1800	←	←	←	←	←	—
Idle throttle valve position	mm	1.30	←	1.40	←	1.50	1.60	—

### MAIN JET CHART

Altitude		Sea Level	600 m 2000 ft	1200 m 4000 ft	1800 m 6000 ft	2400 m 8000 ft	3000 m 10000 ft	Qty
Temperature								
- 40°C - 40°F		290	270	250	230	210	190	3
- 30°C - 20°F		280	260	240	220	200	180	3
<b>- 20°C - 4°F</b>		<b>270</b>	<b>250</b>	<b>230</b>	<b>210</b>	<b>190</b>	<b>170</b>	<b>3</b>
- 10°C 14°F		260	240	220	200	180	160	3
0°C 32°F		250	230	210	190	170	150	3
10°C 50°F		240	220	200	180	160	140	3
20°C 70°F		230	210	190	170	150	130	3

**NOTE:** Arrows in the charts indicate that the preceding information is repeated.



 **WARNING**

For safety reasons, this kit must be installed by an authorized Bombardier snowmobile dealer. Should removal of a locking device be required when undergoing disassembly/assembly, always replace with a new one. This instruction sheet should be given to the purchaser. This kit is designed for specific models. It is not recommended for vehicles other than those for which it was sold.

 **CAUTION**

The following modifications and adjustments apply only for altitudes above 600 m (2000 ft).

NOTE: Installation time is approximately 1.5 hours.

## MODIFICATIONS AND ADJUSTMENTS

The transmission and carburation charts list all parts as well as modifications and adjustments needed for altitude and/or temperature changes.

*High Altitude Technical Data* sheets (P/N 484 300 003) containing technical information pertaining to carburetor jetting, transmission calibration, conversion charts and more, are available. They cover all models for the last 5 years. A convenient binder (P/N 484 054 500) can be ordered to organize the set.

## CARBURETOR JETTING

Stock vehicle jetting and the main jets included in this kit are prescribed for a temperature of - 20°C (- 4°F), as indicated by **bold face type** on the main jet chart. Snowmobile utilization above or below this temperature requires a different jetting. In that case, find the required main jet size in "Carburation" chart and order it according to the Bombardier P/N (part numbers) given in "Main Jet" P/N chart that can be found in the previously mentioned *High Altitude Technical Data* sheets.

# PARTS TO BE INSTALLED

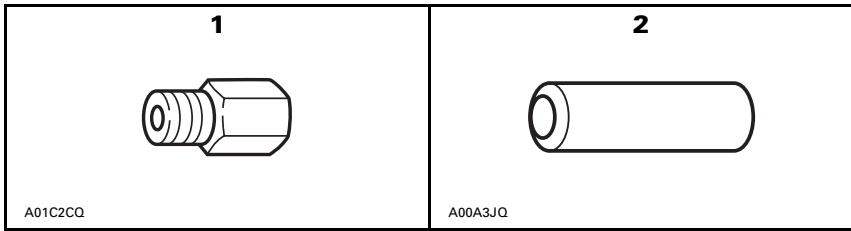

- |    |             |          |     |     |
|----|-------------|----------|-----|-----|
| 1. | 404 101 100 | Main jet | 290 | (3) |
|    | 404 100 400 | Main jet | 270 | (3) |
|    | 404 100 300 | Main jet | 250 | (3) |
|    | 404 118 900 | Main jet | 230 | (3) |
|    | 404 119 100 | Main jet | 210 | (3) |
| 2. | 417 004 309 | Pin      |     | (3) |

# 1999-MACH Z/Z R/Z LT/Z LT R MACH Z M.H. R

## HIGH ALTITUDE KIT (P/N 861 766 600)

### DRIVE PULLEY

Altitude		Sea Level	600 m 2000 ft	1200 m 4000 ft	1800 m 6000 ft	2400 m 8000 ft	3000 m 10000 ft
Clutching	Spring	Green/Blue 414 768 200	←	←	←	←	←
	Ramp	Qty 3 x 1 417 005 295	←	←	←	←	←
	Calibration screw position	3	4	4	4	5	6
	Pin	Qty 3 x 1 417 004 308	←	←	Qty 3 x 1 417 004 309	←	←
	Engagement RPM ± 100	4200	←	←	4500	←	←
	Maximum RPM ± 100	8300	←	←	←	←	←

### DRIVEN PULLEY (Mach Z/Z LT)

Altitude		Sea Level	600 m 2000 ft	1200 m 4000 ft	1800 m 6000 ft	2000 m 8000 ft	3000 m 10000 ft
Clutching	Spring	Beige 414 558 900	←	←	←	←	←
Spring tension	Kg ± 0.7 lb ± 1.5	7.0 15.4	←	←	←	←	←
Cam angle	° (degrees)	53-44 417 126 387	←	←	←	←	←

### DRIVEN PULLEY (Mach Z R/Z M.H. R/Z LT R)

Altitude		Sea Level	600 m 2000 ft	1200 m 4000 ft	1800 m 6000 ft	2000 m 8000 ft	3000 m 10000 ft
Clutching	Spring	Violet 414 978 300	←	←	←	←	←
Spring tension	Kg ± 0.7 lb ± 1.5	0.00	←	←	←	←	←
Cam angle	° (degrees)	47-44 417 126 385	←	←	←	←	←

**NOTE:** Arrows in the charts indicate that the preceding information is repeated.

**Recommendation (Mach Z/Z R/Z M.H. R):** For use at and above 2400m/8000 ft **or** in deep snow; chaincase ratio: 24/43, sprocket 24 teeth, large, (P/N 504 090 900).

**Recommendation (Mach Z LT/Z LT R):** For use at and above 2400m/8000 ft **or** in deep snow; chaincase ratio: 23/43, sprocket 23 teeth, large, (P/N 504 085 400).

# 1999-MACH Z/Z R/Z LT/Z LT R MACH Z M.H. R

## ▼ CAUTION

These adjustments are guidelines only. Specific adjustments vary with temperature, altitude and snow conditions. Always observe spark plug condition for proper jetting.

### CARBURATION

Altitude		Sea Level	600 m 2000 ft	1200 m 4000 ft	1800 m 6000 ft	2400 m 8000 ft	3000 m 10000 ft	Qty
Calibration	Main jet	310 310 310	290 290 290	270 270 270	250 250 250	230 230 230	210 210 210	PTO CTR MAG
	Jet needle	8ADY1-41	←	←	←	←	←	3
Needle position	3	←	2	←	1	←	—	—
Slide cut-away	2.0	←	←	←	←	←	←	3
Pilot jet	50	←	←	←	←	←	←	3
Air screw	4.50	←	←	←	←	←	←	—
Valve seat	1.5	←	←	←	←	←	←	3
Needle jet	O-2 (327)	←	←	←	←	←	←	3
Float level	mm	21.0	←	←	←	←	←	—
Idle	RPM ± 200	1800	←	←	←	←	←	—
Idle throttle valve position	mm	1.30	←	1.40	←	1.50	←	—

### MAIN JET CHART

Altitude		Sea Level	600 m 2000 ft	1200 m 4000 ft	1800 m 6000 ft	2400 m 8000 ft	3000 m 10000 ft	
Temperature	- 40°C - 40°F	330	310	290	270	240	220	PTO/ CTR/MAG
Temperature	- 30°C - 20°F	320	300	280	260	230	210	PTO/ CTR/MAG
Temperature	<b>- 20°C - 4°F</b>	<b>310</b>	<b>290</b>	<b>270</b>	<b>250</b>	<b>230</b>	<b>210</b>	<b>PTO/ CTR/MAG</b>
Temperature	- 10°C 14°F	300	280	260	240	220	200	PTO/ CTR/MAG
Temperature	0°C 32°F	290	270	250	230	210	190	PTO/ CTR/MAG
Temperature	10°C 50°F	280	260	240	220	200	190	PTO/ CTR/MAG
Temperature	20°C 70°F	270	250	230	210	200	180	PTO/ CTR/MAG

**NOTE:** Arrows in the charts indicate that the preceding information is repeated.



 **WARNING**

For safety reasons, this kit must be installed by an authorized Bombardier snowmobile dealer. Should removal of a locking device be required when undergoing disassembly/assembly, always replace with a new one. This instruction sheet should be given to the purchaser. This kit is designed for specific models. It is not recommended for vehicles other than those for which it was sold.

 **CAUTION**

The following modifications and adjustments apply only for altitudes above 600 m (2000 ft).

NOTE: Installation time is approximately 1.5 hours.

## MODIFICATIONS AND ADJUSTMENTS

The transmission and carburation charts list all parts as well as modifications and adjustments needed for altitude and/or temperature changes.

*High Altitude Technical Data* sheets (P/N 484 300 003) containing technical information pertaining to carburetor jetting, transmission calibration, conversion charts and more, are available. They cover all models for the last 5 years. A convenient binder (P/N 484 054 500) can be ordered to organize the set.

## CARBURETOR JETTING

Stock vehicle jetting and the main jets included in this kit are prescribed for a temperature of  $-20^{\circ}\text{C}$  ( $-4^{\circ}\text{F}$ ), as indicated by **bold face type** on the main jet chart. Snowmobile utilization above or below this temperature requires a different jetting. In that case, find the required main jet size in "Carburation" chart and order it according to the Bombardier P/N (part numbers) given in "Main Jet" P/N chart that can be found in the previously mentioned *High Altitude Technical Data* sheets.

# PARTS TO BE INSTALLED

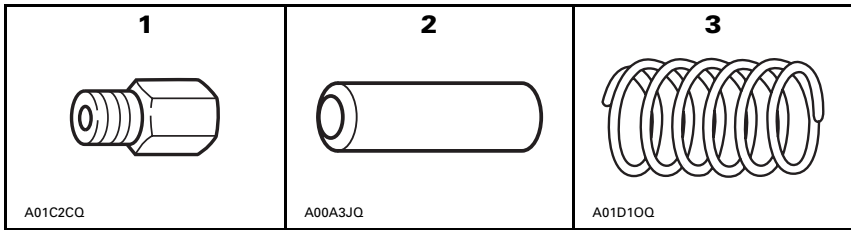

- |    |             |          |            |     |
|----|-------------|----------|------------|-----|
| 1. | 404 100 600 | Main jet | 260        | (1) |
|    | 404 100 300 | Main jet | 250        | (1) |
|    | 404 100 200 | Main jet | 240        | (1) |
|    | 404 118 900 | Main jet | 230        | (1) |
|    | 404 111 200 | Main jet | 220        | (2) |
|    | 404 119 100 | Main jet | 210        | (1) |
|    | 404 112 300 | Main jet | 200        | (2) |
|    | 404 119 000 | Main jet | 190        | (1) |
|    | 404 112 200 | Main jet | 180        | (2) |
| 2. | 417 004 309 | Pin      |            | (3) |
| 3. | 414 768 200 | Spring   | Green/Blue | (1) |

# 1999-FORMULA III 800

## HIGH ALTITUDE KIT (P/N 861 766 800)

### DRIVE PULLEY

Altitude Clutching		Sea Level	600 m 2000 ft	1200 m 4000 ft	1800 m 6000 ft	2400 m 8000 ft	3000 m 10000 ft
Spring		Violet/Blue 415 034 900	←	←	Green/Blue 414 768 200	←	←
Ramp		Qty 3 x 1 417 005 295	←	←	←	←	←
Calibration screw position		3	3	4	4	5	6
Pin		Qty 3 x 1 417 004 308	←	←	Qty 3 x 1 417 004 309	←	←
Engagement RPM ± 100		3800	←	←	4500	←	←
Maximum RPM ± 100		8000	←	←	←	←	←

### DRIVEN PULLEY

Altitude Clutching		Sea Level	600 m 2000 ft	1200 m 4000 ft	1800 m 6000 ft	2000 m 8000 ft	3000 m 10000 ft
Spring		Beige 414 558 900	←	←	←	←	←
Spring tension	Kg ± 0.7 lb ± 1.5	7.0 15.4	←	←	←	←	←
Cam angle	° (degrees)	50-47 417 126 339	←	←	←	←	←

**NOTE:** Arrows in the charts indicate that the preceding information is repeated.

**Recommendation:** For use at and above 2400m/8000 ft **or** in deep snow;  
chaincase ratio: 24/43, sprocket 24 teeth, large, (P/N 504 090 900).



# 1999-FORMULA III 800



## CAUTION

These adjustments are guidelines only. Specific adjustments vary with temperature, altitude and snow conditions. Always observe spark plug condition for proper jetting.

### CARBURATION

Altitude		Sea Level	600 m 2000 ft	1200 m 4000 ft	1800 m 6000 ft	2400 m 8000 ft	3000 m 10000 ft	Qty	
Calibration	Main jet	270 290 280	250 270 260	230 250 240	220 230 220	200 210 200	180 190 180	PTO CTR MAG	
	Jet needle	8ADY1-41	←	←	←	←	←	3	
	Needle position	3	←	2	←	1	←	—	
	Slide cut-away	2.0	←	←	←	←	←	—	
	Pilot jet	50	←	←	←	←	←	3	
	Air screw	4.50	←	←	←	←	←	3	
	Valve seat	1.5	←	←	←	←	←	3	
	Needle jet	O-2 (327)	←	←	←	←	←	3	
	Float level	mm	210	←	←	←	←	←	—
	Idle	RPM ± 200	1800	←	←	←	←	←	—
	Idle throttle valve position	mm	1.30	←	1.40	←	1.50	←	—

### MAIN JET CHART

Altitude		Sea Level	600 m 2000 ft	1200 m 4000 ft	1800 m 6000 ft	2400 m 8000 ft	3000 m 10000 ft	
Temperature	-40°C -40°F	290/ 310/300	270/ 290/280	250/ 270/260	240/ 250/240	220/ 230/220	200/ 210/200	PTO/ CTR/MAG
	-30°C -20°F	280/ 300/290	260 280/270	240/ 260/250	230/ 240/230	210/ 220/210	190/ 200/190	PTO/ CTR/MAG
	<b>-20°C -4°F</b>	<b>270/ 290/280</b>	<b>250/ 270/260</b>	<b>230/ 250/240</b>	<b>220/ 230/220</b>	<b>200/ 210/200</b>	<b>180/ 190/180</b>	<b>PTO/ CTR/MAG</b>
	-10°C 14°F	260/ 280/270	240/ 260/250	220/ 240/230	210/ 220/210	190/ 200/190	170/ 180/170	PTO/ CTR/MAG
	0°C 32°F	250/ 270/260	230/ 250/240	220/ 230/220	200/ 210/200	180/ 190/180	170/ 180/170	PTO/ CTR/MAG
	10°C 50°F	240/ 260/250	220/ 240/230	210/ 220/210	200/ 210/200	180/ 190/180	160/ 170/160	PTO/ CTR/MAG
	20°C 70°F	230/ 250/240	220/ 230/220	210/ 220/210	190/ 200/190	170/ 180/170	150/ 160/150	PTO/ CTR/MAG

**NOTE:** Arrows in the charts indicate that the preceding information is repeated.



 **WARNING**

For safety reasons, this kit must be installed by an authorized Bombardier snowmobile dealer. Should removal of a locking device be required when undergoing disassembly/assembly, always replace with a new one. This instruction sheet should be given to the purchaser. This kit is designed for specific models. It is not recommended for vehicles other than those for which it was sold.

 **CAUTION**

The following modifications and adjustments apply only for altitudes above 600 m (2000 ft).

NOTE: Installation time is approximately 1.5 hours.

## MODIFICATIONS AND ADJUSTMENTS

The transmission and carburation charts list all parts as well as modifications and adjustments needed for altitude and/or temperature changes.

*High Altitude Technical Data* sheets (P/N 484 300 003) containing technical information pertaining to carburetor jetting, transmission calibration, conversion charts and more, are available. They cover all models for the last 5 years. A convenient binder (P/N 484 054 500) can be ordered to organize the set.

## CARBURETOR JETTING

Stock vehicle jetting and the main jets included in this kit are prescribed for a temperature of - 20°C (- 4°F), as indicated by **bold face type** on the main jet chart. Snowmobile utilization above or below this temperature requires a different jetting. In that case, find the required main jet size in "Carburation" chart and order it according to the Bombardier P/N (part numbers) given in "Main Jet" P/N chart that can be found in the previously mentioned *High Altitude Technical Data* sheets.

# PARTS TO BE INSTALLED

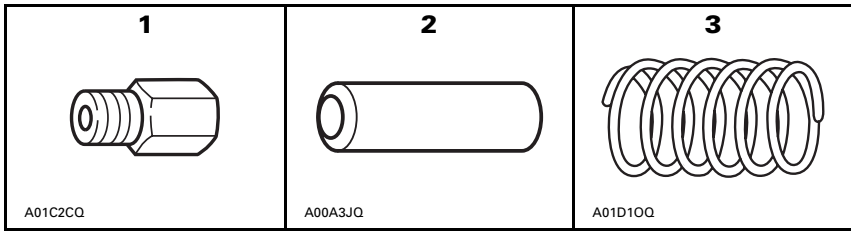

- |    |             |          |            |     |
|----|-------------|----------|------------|-----|
| 1. | 404 100 400 | Main jet | 270        | (3) |
|    | 404 100 300 | Main jet | 250        | (3) |
|    | 404 118 900 | Main jet | 230        | (3) |
|    | 404 119 100 | Main jet | 210        | (3) |
|    | 404 119 000 | Main jet | 190        | (3) |
| 2. | 417 004 309 | Pin      |            | (3) |
| 3. | 414 768 200 | Spring   | Green/Blue | (1) |

# 1999-FORMULA III 700

## HIGH ALTITUDE KIT (P/N 861 766 900)

### DRIVE PULLEY

Altitude		Sea Level	600 m 2000 ft	1200 m 4000 ft	1800 m 6000 ft	2400 m 8000 ft	3000 m 10000 ft
Clutching							
Spring		Violet/Blue 415 034 900	←	←	Green/Blue 414 768 200	←	←
Ramp		Qty 3 x 1 417 005 297	←	←	←	←	←
Calibration screw position		3	3	4	3	4	5
Pin		Qty 3 x 1 417 004 308	←	←	Qty 3 x 1 417 004 309	←	←
Engagement RPM ± 100		3800	←	←	4500	←	←
Maximum RPM ± 100		8000	←	←	←	←	←

### DRIVEN PULLEY

Altitude		Sea Level	600 m 2000 ft	1200 m 4000 ft	1800 m 6000 ft	2000 m 8000 ft	3000 m 10000 ft
Clutching							
Spring		Beige 414 558 900	←	←	←	←	←
Spring tension	Kg ± 0.7 lb ± 1.5	7.0 15.4	←	←	←	←	←
Cam angle	° (degrees)	50-47 417 126 339	←	←	←	←	←

**NOTE:** Arrows in the charts indicate that the preceding information is repeated.

**Recommendation:** For use at and above 2400m/8000 ft **or** in deep snow;  
chaincase ratio: 23/43, sprocket 23 teeth, large, (P/N 504 085 400).

# 1999-FORMULA III 700

## ▼ CAUTION

These adjustments are guidelines only. Specific adjustments vary with temperature, altitude and snow conditions. Always observe spark plug condition for proper jetting.

### CARBURATION

Altitude		Sea Level	600 m 2000 ft	1200 m 4000 ft	1800 m 6000 ft	2400 m 8000 ft	3000 m 10000 ft	Qty
Calibration								
Main jet		290	270	250	230	210	190	PTO CTR MAG
Jet needle		6DEH5	←	←	←	←	←	3
Needle position		3	←	2	←	1	←	—
Slide cut-away		2.5	←	←	←	←	←	—
Pilot jet		50	←	←	←	←	←	3
Air screw		2.50	←	←	←	←	←	3
Valve seat		1.5	←	←	←	←	←	3
Needle jet		P-1 (480)	←	←	←	←	←	3
Float level	mm	18.1	←	←	←	←	←	—
Idle	RPM ± 200	1800	←	←	←	←	←	—
Idle throttle valve position	mm	1.20	←	1.30	1.40	←	1.50	—

### MAIN JET CHART

Altitude		Sea Level	600 m 2000 ft	1200 m 4000 ft	1800 m 6000 ft	2400 m 8000 ft	3000 m 10000 ft	
Temperature								
- 40°C - 40°F		310	290	270	250	230	210	PTO/ CTR/MAG
- 30°C - 20°F		300	280	260	240	220	200	PTO/ CTR/MAG
<b>- 20°C - 4°F</b>		<b>290</b>	<b>270</b>	<b>250</b>	<b>230</b>	<b>210</b>	<b>190</b>	<b>PTO/ CTR/MAG</b>
- 10°C 14°F		280	260	240	220	200	180	PTO/ CTR/MAG
0°C 32°F		270	250	230	210	190	180	PTO/ CTR/MAG
10°C 50°F		260	240	220	210	190	170	PTO/ CTR/MAG
20°C 70°F		250	230	210	200	180	160	PTO/ CTR/MAG

**NOTE:** Arrows in the charts indicate that the preceding information is repeated.



 **WARNING**

For safety reasons, this kit must be installed by an authorized Bombardier snowmobile dealer. Should removal of a locking device be required when undergoing disassembly/assembly, always replace with a new one. This instruction sheet should be given to the purchaser. This kit is designed for specific models. It is not recommended for vehicles other than those for which it was sold.

 **CAUTION**

The following modifications and adjustments apply only for altitudes above 600 m (2000 ft).

**NOTE:** Installation time is approximately 1.5 hours.

## MODIFICATIONS AND ADJUSTMENTS

The transmission and carburation charts list all parts as well as modifications and adjustments needed for altitude and/or temperature changes.

*High Altitude Technical Data* sheets (P/N 484 300 003) containing technical information pertaining to carburetor jetting, transmission calibration, conversion charts and more, are available. They cover all models for the last 5 years. A convenient binder (P/N 484 054 500) can be ordered to organize the set.

## CARBURETOR JETTING

Stock vehicle jetting and the main jets included in this kit are prescribed for a temperature of - 20°C (- 4°F), as indicated by **bold face type** on the main jet chart. Snowmobile utilization above or below this temperature requires a different jetting. In that case, find the required main jet size in "Carburation" chart and order it according to the Bombardier P/N (part numbers) given in "Main Jet" P/N chart that can be found in the previously mentioned *High Altitude Technical Data* sheets.

## PARTS TO BE INSTALLED

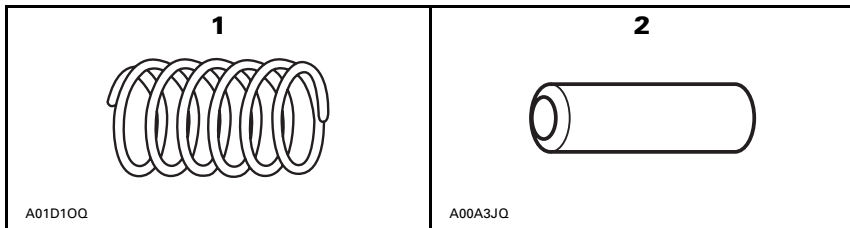

- |    |             |        |               |     |
|----|-------------|--------|---------------|-----|
| 1. | 415 015 300 | Spring | Violet/Yellow | (1) |
| 2. | 417 004 309 | Pin    |               | (3) |

# 1999-GRAND TOURING SE

## HIGH ALTITUDE KIT (P/N 861 768 000)

### DRIVE PULLEY

Altitude Clutching	Sea Level	600 m 2000 ft	1200 m 4000 ft	1800 m 6000 ft	2400 m 8000 ft	3000 m 10000 ft
	Spring	Yellow/ Orange 414 689 700	←	←	Violet/ Yellow 415 015 300	←
Ramp	Qty 3 x 1 417 005 297	←	←	←	←	←
Calibration screw position	3	4	5	4	5	6
Pin	Qty 3 x 1 417 004 308	←	←	Qty 3 x 1 417 004 309	←	←
Engagement RPM ± 100	3300	←	←	4200	←	←
Maximum RPM ± 100	8000	←	←	←	←	←

### DRIVEN PULLEY

Altitude Clutching	Sea Level	600 m 2000 ft	1200 m 4000 ft	1800 m 6000 ft	2000 m 8000 ft	3000 m 10000 ft
	Spring	Violet 414 978 300	←	←	←	←
Spring tension	Kg ± 0.7 lb ± 1.5	0.00	←	←	←	←
Cam angle	° (degrees)	47-44 417 126 385	←	←	←	←

**NOTE:** Arrows in the charts indicate that the preceding information is repeated.

**Recommendation:** At and above 2400 m/8000 ft **or** in deep snow; chaincase ratio: 22/43 with 70 links chain, (P/N 412 106 800), sprocket 22 teeth, large, (P/N 504 083 500).



# 1999-GRAND TOURING SE

## ▼ CAUTION

These adjustments are guidelines only. Specific adjustments vary with temperature, altitude and snow conditions. Always observe spark plug condition for proper jetting.

### CARBURATION

Altitude		Sea Level	600 m 2000 ft	1200 m 4000 ft	1800 m 6000 ft	2400 m 8000 ft	3000 m 10000 ft	Qty
Calibration								
Main jet		270 290 280	←	←	←	←	←	PTO CTR MAG
Jet needle		8ADY1-41	←	←	←	←	←	3
Needle position		3	←	←	←	←	←	—
Slide cut-away		2.0	←	←	←	←	←	3
Pilot jet		50	←	←	←	←	←	3
Air screw		4.50	←	←	←	←	←	3
Valve seat		1.5	←	←	←	←	←	3
Needle jet		O-2 (327)	←	←	←	←	←	3
Float level	mm	21.0	←	←	←	←	←	—
Idle	RPM ± 200	1800	←	←	←	←	←	—
Idle throttle valve position	mm	1.30	←	←	1.40	←	1.50	—

### MAIN JET CHART

Altitude		Sea Level	600 m 2000 ft	1200 m 4000 ft	1800 m 6000 ft	2400 m 8000 ft	3000 m 10000 ft	Qty
Temperature								
- 40°C - 40°F		290 310 300	←	←	←	←	←	PTO CTR MAG
- 30°C - 20°F		280 300 290	←	←	←	←	←	PTO CTR MAG
- 20°C - 4°F		<b>270</b> <b>290</b> <b>280</b>	←	←	←	←	←	<b>PTO</b> <b>CTR</b> <b>MAG</b>
- 10°C 14°F		270 290 280	←	←	←	←	←	PTO CTR MAG
0°C 32°F		270 290 280	←	←	←	←	←	PTO CTR MAG
10°C 50°F		270 290 280	←	←	←	←	←	PTO CTR MAG
20°C 70°F		270 290 280	←	←	←	←	←	PTO CTR MAG

**NOTE:** Arrows in the charts indicate that the preceding information is repeated.



 **WARNING**

For safety reasons, this kit must be installed by an authorized Bombardier snowmobile dealer. Should removal of a locking device be required when undergoing disassembly/assembly, always replace with a new one. This instruction sheet should be given to the purchaser. This kit is designed for specific models. It is not recommended for vehicles other than those for which it was sold.

 **CAUTION**

The following modifications and adjustments apply only for altitudes above 600 m (2000 ft).

**NOTE:** Installation time is approximately 1.5 hours.

## MODIFICATIONS AND ADJUSTMENTS

The transmission and carburation charts list all parts as well as modifications and adjustments needed for altitude and/or temperature changes.

*High Altitude Technical Data* sheets (P/N 484 300 003) containing technical information pertaining to carburetor jetting, transmission calibration, conversion charts and more, are available. They cover all models for the last 5 years. A convenient binder (P/N 484 054 500) can be ordered to organize the set.

## CARBURETOR JETTING

Stock vehicle jetting and the main jets included in this kit are prescribed for a temperature of - 20°C (- 4°F), as indicated by **bold face type** on the main jet chart. Snowmobile utilization above or below this temperature requires a different jetting. In that case, find the required main jet size in "Carburation" chart and order it according to the Bombardier P/N (part numbers) given in "Main Jet" P/N chart that can be found in the previously mentioned *High Altitude Technical Data* sheets.

## PARTS TO BE INSTALLED

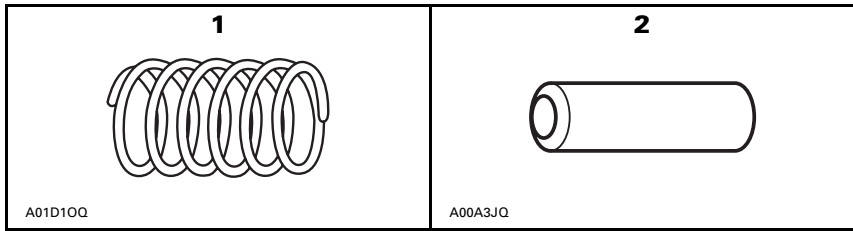

- |    |             |        |               |     |
|----|-------------|--------|---------------|-----|
| 1. | 415 015 300 | Spring | Violet/Yellow | (1) |
| 2. | 417 004 309 | Pin    |               | (3) |

# 1999-GRAND TOURING 700

## HIGH ALTITUDE KIT (P/N 861 768 100)

### DRIVE PULLEY

Altitude Clutching		Sea Level	600 m 2000 ft	1200 m 4000 ft	1800 m 6000 ft	2400 m 8000 ft	3000 m 10000 ft
Spring		Yellow/Red 414 993 000	←	←	Violet/Yellow 415 015 300	←	←
Ramp		Qty 3 x 1 417 005 285	←	←	←	←	←
Calibration screw position		4	5	6	4	5	6
Pin		Qty 3 x 1 417 004 308	←	←	Qty 3 x 1 417 004 309	←	←
Engagement RPM ± 100		3300	←	←	4200	←	←
Maximum RPM ± 100		8000	←	←	←	←	←

### DRIVEN PULLEY

Altitude Clutching		Sea Level	600 m 2000 ft	1200 m 4000 ft	1800 m 6000 ft	2000 m 8000 ft	3000 m 10000 ft
Spring		Violet 414 978 300	←	←	←	←	←
Spring tension	Kg ± 0.7 lb ± 1.5	0.00	←	←	←	←	←
Cam angle	° (degrees)	47-44 417 126 385	←	←	←	←	←

**NOTE:** Arrows in the charts indicate that the preceding information is repeated.

**Recommendation:** At and above 2400 m/8000 ft **or** in deep snow; chaincase ratio: 22/43 with 70 links chain, (P/N 412 106 800), sprocket 22 teeth, large, (P/N 504 083 500).

# 1999-GRAND TOURING 700

## ▼ CAUTION

These adjustments are guidelines only. Specific adjustments vary with temperature, altitude and snow conditions. Always observe spark plug condition for proper jetting.

### CARBURATION

Altitude		Sea Level	600 m 2000 ft	1200 m 4000 ft	1800 m 6000 ft	2400 m 8000 ft	3000 m 10000 ft	
Calibration								
Main jet		290	290	290	290	290	290	PTO CTR MAG
Jet needle		6DEH5	←	←	←	←	←	—
Needle position		3	←	←	←	←	←	—
Slide cut-away		2.5	←	←	←	←	←	—
Pilot jet		50	←	←	←	←	←	—
Air screw		2.50	←	←	←	←	←	—
Valve seat		1.5	←	←	←	←	←	—
Needle jet		P-1 (480)	←	←	←	←	←	—
Float level	mm	18.1	←	←	←	←	←	—
Idle	RPM ± 200	1800	←	←	←	←	←	—
Idle throttle valve position	mm	1.20	←	1.30	1.40	←	1.50	—

### MAIN JET CHART

Altitude		Sea Level	600 m 2000 ft	1200 m 4000 ft	1800 m 6000 ft	2400 m 8000 ft	3000 m 10000 ft	
Temperature								
- 40°C - 40°F		310	←	←	←	←	←	PTO CTR MAG
- 30°C - 20°F		300	←	←	←	←	←	PTO CTR MAG
- 20°C - 4°F		290	←	←	←	←	←	PTO CTR MAG
- 10°C 14°F		290	←	←	←	←	←	PTO CTR MAG
0°C 32°F		290	←	←	←	←	←	PTO CTR MAG
10°C 50°F		290	←	←	←	←	←	PTO CTR MAG
20°C 70°F		290	←	←	←	←	←	PTO CTR MAG

NOTE: Arrows in the charts indicate that the preceding information is repeated.



## **WARNING**

For safety reasons, this kit must be installed by an authorized Bombardier snowmobile dealer. Should removal of a locking device be required when undergoing disassembly/assembly, always replace with a new one. This instruction sheet should be given to the purchaser. This kit is designed for specific models. It is not recommended for vehicles other than those for which it was sold.



## **CAUTION**

The following modifications and adjustments apply only for altitudes above 600 m (2000 ft).

**NOTE:** Installation time is approximately 1.5 hours.

## **MODIFICATIONS AND ADJUSTMENTS**

The transmission and carburation charts list all parts as well as modifications and adjustments needed for altitude and/or temperature changes.

*High Altitude Technical Data* sheets (P/N 484 300 003) containing technical information pertaining to carburetor jetting, transmission calibration, conversion charts and more, are available. They cover all models for the last 5 years. A convenient binder (P/N 484 054 500) can be ordered to organize the set.

## **CARBURETOR JETTING**

Stock vehicle jetting and the main jets included in this kit are prescribed for a temperature of - 20°C (- 4°F), as indicated by **bold face type** on the main jet chart. Snowmobile utilization above or below this temperature requires a different jetting. In that case, find the required main jet size in "Carburation" chart and order it according to the Bombardier P/N (part numbers) given in "Main Jet" P/N chart that can be found in the previously mentioned *High Altitude Technical Data* sheets.

# PARTS TO BE INSTALLED

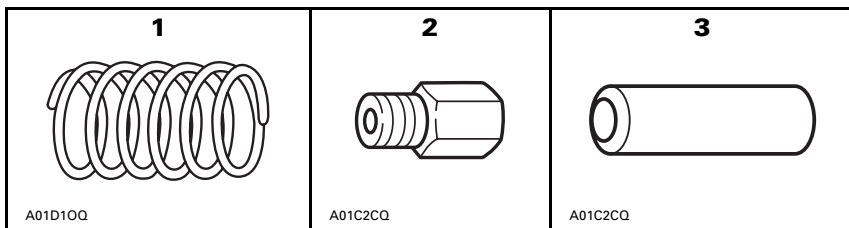

- |    |             |          |         |     |
|----|-------------|----------|---------|-----|
| 1. | 414 689 800 | Spring   | Red/Red | (1) |
| 2. | 404 118 900 | Main jet | 230     | (1) |
|    | 404 111 200 | Main jet | 220     | (1) |
|    | 404 119 100 | Main jet | 210     | (1) |
|    | 404 112 300 | Main jet | 200     | (2) |
|    | 404 119 000 | Main jet | 190     | (2) |
| 3. | 417 004 309 | Pin      |         | (3) |

# 1999-SKANDIC WT LC

## HIGH ALTITUDE KIT (P/N 861 769 000)

### DRIVE PULLEY

Altitude Clutching		Sea Level	600 m 2000 ft	1200 m 4000 ft	1800 m 6000 ft	2400 m 8000 ft	3000 m 10000 ft
Spring		Yellow/Blue 414 818 000	←	Red/Red 414 689 800	←	←	←
Ramp		Qty 3 x 1 417 005 290	←	←	←	←	←
Calibration screw position		4	5	1	2	3	4
Pin		Qty 3 x 1 417 004 308	←	Qty 3 x 1 417 004 309	←	←	←
Engagement RPM ± 100		2500	←	←	←	←	←
Maximum RPM ± 100		7000	←	←	←	←	←

### DRIVEN PULLEY

Altitude Clutching		Sea Level	600 m 2000 ft	1200 m 4000 ft	1800 m 6000 ft	2000 m 8000 ft	3000 m 10000 ft
Spring		Blue A C S 3 - 188	←	←	←	←	←
Spring tension	Kg ± 0.7 lb ± 1.5	7.0 15.4	←	←	←	←	←
Cam angle	° (degrees)	40	←	←	←	←	←

**NOTE:** Arrows in the charts indicate that the preceding information is repeated.



# 1999-SKANDIC WT LC

## ▼ CAUTION

These adjustments are guidelines only. Specific adjustments vary with temperature, altitude and snow conditions. Always observe spark plug condition for proper jetting.

### CARBURATION

Altitude		Sea Level	600 m 2000 ft	1200 m 4000 ft	1800 m 6000 ft	2400 m 8000 ft	3000 m 10000 ft	Qty
Calibration								
Main jet		250 240	240 230	230 220	220 210	200 200	190 190	PTO MAG
Jet needle		6DH4	←	←	←	←	←	2
Needle position		2	←	←	←	←	←	—
Slide cut-away		2.5	←	←	←	←	←	2
Pilot jet		40	←	←	←	←	←	2
Air screw		1.0	←	←	0.5	←	←	—
Valve seat		1.5	←	←	←	←	←	2
Needle jet		P-2 (159)	←	←	←	←	←	2
Float level	mm	36.5	←	←	←	←	←	—
Idle	RPM ± 200	1900	←	←	←	←	←	—
Idle throttle valve position	mm	1.5	1.6	1.7	1.8	1.9	2.0	—

### MAIN JET CHART

Altitude		Sea Level	600 m 2000 ft	1200 m 4000 ft	1800 m 6000 ft	2400 m 8000 ft	3000 m 10000 ft	
Temperature								
- 40°C - 40°F		270 260	260 250	250 240	240 230	230 220	220 210	PTO MAG
- 30°C - 20°F		260 250	250 240	240 230	230 220	220 210	210 200	PTO MAG
<b>- 20°C - 4°F</b>		<b>250 240</b>	<b>240 230</b>	<b>230 220</b>	<b>220 210</b>	<b>210 200</b>	<b>200 190</b>	<b>PTO MAG</b>
- 10°C 14°F		240 230	230 220	220 210	210 200	200 190	190 180	PTO MAG
0°C 32°F		230 220	220 210	210 200	200 190	190 180	180 170	PTO MAG
10°C 50°F		220 210	210 200	200 190	190 180	180 170	170 160	PTO MAG
20°C 70°F		210 200	200 190	190 180	170 170	160 160	150 150	PTO MAG

**NOTE:** Arrows in the charts indicate that the preceding information is repeated.



## **WARNING**

For safety reasons, this kit must be installed by an authorized Bombardier snowmobile dealer. Should removal of a locking device be required when undergoing disassembly/assembly, always replace with a new one. This instruction sheet should be given to the purchaser. This kit is designed for specific models. It is not recommended for vehicles other than those for which it was sold.



## **CAUTION**

The following modifications and adjustments apply only for altitudes above 600 m (2000 ft).

**NOTE:** Installation time is approximately 1.5 hours.

## **MODIFICATIONS AND ADJUSTMENTS**

The transmission and carburation charts list all parts as well as modifications and adjustments needed for altitude and/or temperature changes.

*High Altitude Technical Data* sheets (P/N 484 300 003) containing technical information pertaining to carburetor jetting, transmission calibration, conversion charts and more, are available. They cover all models for the last 5 years. A convenient binder (P/N 484 054 500) can be ordered to organize the set.

## **CARBURETOR JETTING**

Stock vehicle jetting and the main jets included in this kit are prescribed for a temperature of - 20°C (- 4°F), as indicated by **bold face type** on the main jet chart. Snowmobile utilization above or below this temperature requires a different jetting. In that case, find the required main jet size in "Carburation" chart and order it according to the Bombardier P/N (part numbers) given in "Main Jet" P/N chart that can be found in the previously mentioned *High Altitude Technical Data* sheets.

# PARTS TO BE INSTALLED

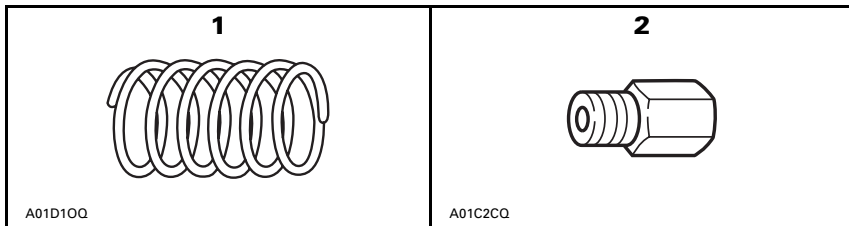

- |    |             |          |            |     |
|----|-------------|----------|------------|-----|
| 1. | 414 817 700 | Spring   | Blue/Green | (1) |
| 2. | 404 112 300 | Main jet | 200        | (2) |
|    | 404 119 000 | Main jet | 190        | (2) |
|    | 404 112 200 | Main jet | 180        | (2) |
|    | 404 123 800 | Main jet | 170        | (2) |
|    | 404 118 200 | Main jet | 160        | (2) |

# 1999-SKANDIC WT

## HIGH ALTITUDE KIT (P/N 861 769 100)

### DRIVE PULLEY

Altitude		Sea Level	600 m 2000 ft	1200 m 4000 ft	1800 m 6000 ft	2400 m 8000 ft	3000 m 10000 ft
Clutching							
Spring		Yellow/Orange 414 689 700	←	←	Blue/Green 414 817 700	←	←
Ramp		Qty 3 x 1 417 005 290	←	←	←	←	←
Calibration screw position		4	5	6	2	3	4
Pin		Qty 3 x 1 417 004 309	←	←	←	←	←
Engagement RPM ± 100		3000	←	←	3300	←	←
Maximum RPM ± 100		6800	←	←	←	←	←

### DRIVEN PULLEY

Altitude		Sea Level	600 m 2000 ft	1200 m 4000 ft	1800 m 6000 ft	2000 m 8000 ft	3000 m 10000 ft
Clutching							
Spring		Blue A C S 3 - 188	←	←	←	←	←
Spring tension	Kg ± 0.7 lb ± 1.5	7.0 15.4	←	←	←	←	←
Cam angle	° (degrees)	40	←	←	←	←	←

**NOTE:** Arrows in the charts indicate that the preceding information is repeated.

# 1999-SKANDIC WT



## CAUTION

These adjustments are guidelines only. Specific adjustments vary with temperature, altitude and snow conditions. Always observe spark plug condition for proper jetting.

### CARBURATION

Altitude		Sea Level	600 m 2000 ft	1200 m 4000 ft	1800 m 6000 ft	2400 m 8000 ft	3000 m 10000 ft	Qty
Calibration								
Main jet		210	200	190	180	170	160	2
Jet needle		6DH2	←	←	←	←	←	2
Needle position		3	←	←	←	←	←	—
Slide cut-away		2.5	←	←	←	←	←	2
Pilot jet		40	←	←	←	←	←	2
Air screw		1.0	←	←	0.75	←	←	—
Valve seat		1.5	←	←	←	←	←	2
Needle jet		P-2 (159)	←	←	←	←	←	2
Float level	mm	36.5	←	←	←	←	←	—
Idle	RPM ± 200	1650	←	←	←	←	←	—
Idle throttle valve position	mm	1.5	←	1.6	1.7	1.8	1.9	—

### MAIN JET CHART

Altitude		Sea Level	600 m 2000 ft	1200 m 4000 ft	1800 m 6000 ft	2400 m 8000 ft	3000 m 10000 ft	Qty
Temperature								
- 40°C - 40°F		230	220	210	200	190	180	2
- 30°C - 20°F		220	210	200	190	180	170	2
- 20°C - 4°F		<b>210</b>	<b>200</b>	<b>190</b>	<b>180</b>	<b>170</b>	<b>160</b>	<b>2</b>
- 10°C 14°F		205	190	180	170	160	150	2
0°C 32°F		200	190	180	165	155	145	2
10°C 50°F		190	180	170	160	150	140	2
20°C 70°F		180	170	160	150	140	130	2

NOTE: Arrows in the charts indicate that the preceding information is repeated.



## **WARNING**

For safety reasons, this kit must be installed by an authorized Bombardier snowmobile dealer. Should removal of a locking device be required when undergoing disassembly/assembly, always replace with a new one. This instruction sheet should be given to the purchaser. This kit is designed for specific models. It is not recommended for vehicles other than those for which it was sold.



## **CAUTION**

The following modifications and adjustments apply only for altitudes above 600 m (2000 ft).

**NOTE:** Installation time is approximately 1.5 hours.

## **MODIFICATIONS AND ADJUSTMENTS**

The transmission and carburation charts list all parts as well as modifications and adjustments needed for altitude and/or temperature changes.

*High Altitude Technical Data* sheets (P/N 484 300 003) containing technical information pertaining to carburetor jetting, transmission calibration, conversion charts and more, are available. They cover all models for the last 5 years. A convenient binder (P/N 484 054 500) can be ordered to organize the set.

## **CARBURETOR JETTING**

Stock vehicle jetting and the main jets included in this kit are prescribed for a temperature of - 20°C (- 4°F), as indicated by **bold face type** on the main jet chart. Snowmobile utilization above or below this temperature requires a different jetting. In that case, find the required main jet size in "Carburation" chart and order it according to the Bombardier P/N (part numbers) given in "Main Jet" P/N chart that can be found in the previously mentioned *High Altitude Technical Data* sheets.

# PARTS TO BE INSTALLED

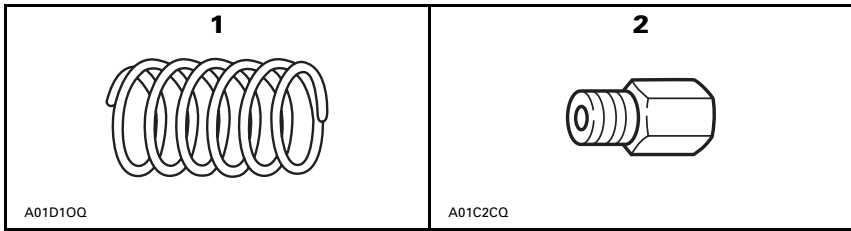

- |    |             |          |             |     |
|----|-------------|----------|-------------|-----|
| 1. | 414 689 500 | Spring   | Blue/Yellow | (1) |
| 2. | 404 112 200 | Main jet | 180         | (1) |
|    | 404 119 200 | Main jet | 175         | (1) |
|    | 404 123 800 | Main jet | 170         | (1) |
|    | 404 119 300 | Main jet | 165         | (1) |
|    | 404 118 200 | Main jet | 160         | (1) |
|    | 404 128 700 | Main jet | 155         | (1) |

# 1999-SKANDIC SWT

## HIGH ALTITUDE KIT (P/N 861 769 200)

### DRIVE PULLEY

Altitude		Sea Level	600 m 2000 ft	1200 m 4000 ft	1800 m 6000 ft	2400 m 8000 ft	3000 m 10000 ft
Clutching							
Spring		Yellow/Orange 414 689 700	←	←	←	←	Blue/Yellow 414 689 500
Ramp		Qty 3 x 1 417 005 290	←	←	←	←	←
Calibration screw position		2	3	4	5	6	3
Pin		Qty 3 x 1 417 004 309	←	←	←	←	←
Engagement RPM ± 100		3000	←	←	←	←	3300
Maximum RPM ± 100		6800	←	←	←	←	←

### DRIVEN PULLEY

Altitude		Sea Level	600 m 2000 ft	1200 m 4000 ft	1800 m 6000 ft	2000 m 8000 ft	3000 m 10000 ft
Clutching							
Spring		Blue A C S 3 - 188	←	←	←	←	←
Spring tension	Kg ± 0.7 lb ± 1.5	7.0 15.4	←	←	←	←	←
Cam angle	° (degrees)	40	←	←	←	←	←

**NOTE:** Arrows in the charts indicate that the preceding information is repeated.



# 1999-SKANDIC SWT

## ▼ CAUTION

These adjustments are guidelines only. Specific adjustments vary with temperature, altitude and snow conditions. Always observe spark plug condition for proper jetting.

### CARBURATION

Altitude		Sea Level	600 m 2000 ft	1200 m 4000 ft	1800 m 6000 ft	2400 m 8000 ft	3000 m 10000 ft	Qty
Calibration								
Main jet		185 185	180 175	175 170	170 165	165 160	160 155	PTO MAG
Jet needle		6DH2	←	←	←	←	←	1
Needle position		3	←	←	←	←	←	—
Slide cut-away		2.5	←	←	←	←	←	1
Pilot jet		40	←	←	←	←	←	1
Air screw		1.25	←	←	←	←	←	—
Valve seat		1.5	←	←	←	←	←	2
Needle jet		P-1 (159)	←	←	←	←	←	1
Float level	mm	36.5	←	←	←	←	←	—
Idle	RPM ± 200	1650	←	←	←	←	←	—
Idle throttle valve position	mm	1.5	←	←	←	←	←	—

### MAIN JET CHART

Altitude		Sea Level	600 m 2000 ft	1200 m 4000 ft	1800 m 6000 ft	2400 m 8000 ft	3000 m 10000 ft	Qty
Temperature								
- 40°C		205	200	195	190	185	180	PTO MAG
- 40°F		205	195	190	185	180	175	
- 30°C		195	190	185	180	175	170	PTO MAG
- 20°F		195	185	180	175	170	165	
- 20°C		<b>185</b>	<b>180</b>	<b>175</b>	<b>170</b>	<b>165</b>	<b>160</b>	PTO MAG
- 4°F		<b>185</b>	<b>175</b>	<b>170</b>	<b>165</b>	<b>160</b>	<b>155</b>	
- 10°C		180	175	170	165	160	155	PTO MAG
14°F		180	170	165	160	155	150	
0°C		175	170	165	160	155	150	PTO MAG
32°F		175	165	160	155	150	145	
10°C		170	165	160	155	150	145	PTO MAG
50°F		170	160	155	150	145	140	
20°C		170	165	155	155	150	145	PTO MAG
70°F		170	160	150	150	145	140	

**NOTE:** Arrows in the charts indicate that the preceding information is repeated.



 **WARNING**

For safety reasons, this kit must be installed by an authorized Bombardier snowmobile dealer. Should removal of a locking device be required when undergoing disassembly/assembly, always replace with a new one. This instruction sheet should be given to the purchaser. This kit is designed for specific models. It is not recommended for vehicles other than those for which it was sold.

 **CAUTION**

The following modifications and adjustments apply only for altitudes from and below 1800 m (6000 ft).

**Failure to comply with this kit requirements at altitudes from and below 1800 m (6 000 ft) may cause serious engine damage.**

NOTE: Installation time is approximately 1.5 hours.

## MODIFICATIONS AND ADJUSTMENTS

The transmission and carburation charts list all parts as well as modifications and adjustments needed for altitude and/or temperature changes.

*High Altitude and Sea Level Technical Data* sheets (P/N 484 300 003) containing technical information pertaining to carburetor jetting, transmission calibration, conversion charts and more, are available. They cover all models for the last 5 years. A convenient binder (P/N 484 054 500) can be ordered to organize the set.

## CARBURETOR JETTING

Stock vehicle jetting and the main jets included in this kit are prescribed for a temperature of - 20°C (- 4°F), as indicated by **bold face type** on the main jet chart. Snowmobile utilization above or below this temperature requires a different jetting. In that case, find the required main jet size in "Carburation" chart and order it according to the Bombardier P/N (part numbers) given in "Main Jet" P/N chart that can be found in the previously mentioned *High Altitude Technical Data* sheets.

## PARTS TO BE INSTALLED

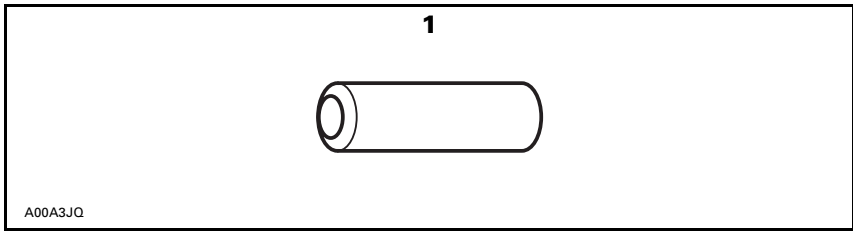

1. 417 004 308 Pin (3)

# 1999-SUMMIT 700

## SEA LEVEL KIT (P/N 861 771 500)

### DRIVE PULLEY

Altitude Clutching	Sea Level	600 m 2000 ft	1200 m 4000 ft	1800 m 6000 ft	2400 m 8000 ft	3000 m 10000 ft
Spring	←	←	←	←	Violet/ Yellow 415 015 300	←
Ramp	←	←	←	←	297 417 005 297	←
Calibration screw position	3	4	2	3	4	5
Pin	←	Qty 3 x 1 417 004 308	←	←	Qty 3 x 1 417 004 309	←
Engagement RPM ± 100	←	←	←	←	4100←	←
Maximum RPM ± 100	←	←	←	←	8000	←

### DRIVEN PULLEY (Both Models)

Altitude Clutching	Sea Level	600 m 2000 ft	1200 m 4000 ft	1800 m 6000 ft	2000 m 8000 ft	3000 m 10000 ft
Spring	←	←	←	←	Beige 414 558 900	←
Spring tension	Kg ± 0.7 lb ± 1.5	←	←	←	7.0 15.4	←
Cam angle	° (degrees)				47 417 126 337	

**NOTE:** Arrows in the charts indicate that the preceding information is repeated.

**Additional Information:** Use a large 24 teeth sprocket (P/N 504 090 900) at sea level to obtain a chain case ratio of 24/43.

# 1999-SUMMIT 700

## ▼ CAUTION

These adjustments are guidelines only. Specific adjustments vary with temperature, altitude and snow conditions. Always observe spark plug condition for proper jetting.

### CARBURATION

Altitude		Sea Level	600 m 2000 ft	1200 m 4000 ft	1800 m 6000 ft	2400 m 8000 ft	3000 m 10000 ft	Qty
Calibration								
Main jet		←	←	←	←	310	←	2
Jet needle		←	←	←	←	7DHY1	←	2
Needle position		←	←	←	←	4	←	—
Slide cut-away		←	←	←	←	2.5	←	2
Pilot jet		←	←	←	←	40	←	2
Air screw		←	←	←	←	1.0	←	2
Valve seat		←	←	←	←	1.5 (V)	←	2
Needle jet		←	←	←	←	Z-5 (224)	←	2
Float level	mm	←	←	←	←	22.9	←	—
Idle	RPM ± 200	←	←	←	←	1600	←	—
Idle throttle valve position	mm	←	←	←	←	1.9	←	—

### MAIN JET CHART

Altitude		Sea Level	600 m 2000 ft	1200 m 4000 ft	1800 m 6000 ft	2400 m 8000 ft	3000 m 10000 ft	Qty
Temperature								
- 40°C - 40°F		←	←	←	←	←	←	PTO MAG
- 30°C - 20°F		←	←	←	←	←	←	PTO MAG
- 20°C - 4°F		310	310	310	310	310	310	PTO MAG
- 10°C 14°F		←	←	←	←	←	←	PTO MAG
0°C 32°F		←	←	←	←	←	←	PTO MAG
10°C 50°F		←	←	←	←	←	←	PTO MAG
20°C 70°F		←	←	←	←	←	←	PTO MAG

**NOTE:** Arrows in the charts indicate that the preceding information is repeated.



## **WARNING**

For safety reasons, this kit must be installed by an authorized Bombardier snowmobile dealer. Should removal of a locking device be required when undergoing disassembly/assembly, always replace with a new one. This instruction sheet should be given to the purchaser. This kit is designed for specific models. It is not recommended for vehicles other than those for which it was sold.



## **CAUTION**

The following modifications and adjustments apply only for altitudes above 600 m (2000 ft).

**NOTE:** Installation time is approximately 1.5 hours.

**IMPORTANT:** Do not use the informations received previously.

## **MODIFICATIONS AND ADJUSTMENTS**

The transmission and carburation charts list all parts as well as modifications and adjustments needed for altitude and/or temperature changes.

*High Altitude Technical Data* sheets (P/N 484 300 003) containing technical information pertaining to carburetor jetting, transmission calibration, conversion charts and more, are available. They cover all models for the last 5 years. A convenient binder (P/N 484 054 500) can be ordered to organize the set.

## **CARBURETOR JETTING**

Stock vehicle jetting and the main jets included in this kit are prescribed for a temperature of - 20°C (- 4°F), as indicated by **bold face type** on the main jet chart. Snowmobile utilization above or below this temperature requires a different jetting. In that case, find the required main jet size in "Carburation" chart and order it according to the Bombardier P/N (part numbers) given in "Main Jet" P/N chart that can be found in the previously mentioned *High Altitude Technical Data* sheets.

# PARTS TO BE INSTALLED

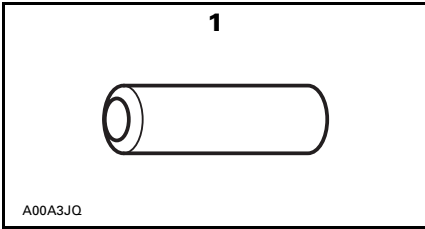

1. 417 004 309 Pin

(3)

# 1999-MX Z 700

## HIGH ALTITUDE KIT (P/N 861 771 600)

### DRIVE PULLEY

Altitude		Sea Level	600 m 2000 ft	1200 m 4000 ft	1800 m 6000 ft	2400 m 8000 ft	3000 m 10000 ft
Clutching							
Spring		Violet/Yellow 415 015 300	←	←	←	←	←
Ramp		Qty 3 x 1 417 005 297	←	←	←	←	←
Calibration screw position		3	4	2	3	4	5
Pin		Qty 3 x 1 417 004 308	←	Qty 3 x 1 417 004 309	←	←	←
Engagement RPM ± 100		3800	←	4100	←	←	←
Maximum RPM ± 100		8000	←	←	←	←	←

### DRIVEN PULLEY

Altitude		Sea Level	600 m 2000 ft	1200 m 4000 ft	1800 m 6000 ft	2000 m 8000 ft	3000 m 10000 ft
Clutching							
Spring		Beige 414 558 900	←	←	←	←	←
Spring tension	Kg ± 0.7 lb ± 1.5	7.0 15.4	←	←	←	←	←
Cam angle	° (degrees)	47° 417 126 337	←	←	←	←	←

**NOTE:** Arrows in the charts indicate that the preceding information is repeated.

**Additional Information:** From 2400 m (8000 ft) and above, or in deep snow, install a large 23 teeth sprocket (P/N 504 085 400) to set chain case ratio to 23/43.



# 1999-MX Z 700

## ▼ CAUTION

These adjustments are guidelines only. Specific adjustments vary with temperature, altitude and snow conditions. Always observe spark plug condition for proper jetting.

### CARBURATION

Altitude		Sea Level	600 m 2000 ft	1200 m 4000 ft	1800 m 6000 ft	2400 m 8000 ft	3000 m 10000 ft	Qty
Calibration								
Main jet		310 310	310 310	310 310	310 310	310 310	310 310	PTO MAG
Jet needle		7DHY6	←	←	←	←	←	2
Needle position		4	←	←	←	←	←	—
Slide cut-away		2.5	←	←	←	←	←	2
Pilot jet		40	←	←	←	←	←	2
Air screw		1.0	←	←	←	←	←	—
Valve seat		1.5 (V)	←	←	←	←	←	2
Needle jet		Z-5 (224)	←	←	←	←	←	2
Float level	mm	22.9	←	←	←	←	←	—
Idle	RPM ± 200	1600	←	←	←	←	←	—
Idle throttle valve position	mm	1.5	1.6	1.7	1.8	1.9	2.0	—

### MAIN JET CHART

Altitude		Sea Level	600 m 2000 ft	1200 m 4000 ft	1800 m 6000 ft	2400 m 8000 ft	3000 m 10000 ft	
Temperature								
- 40°C - 40°F		←	←	←	←	←	←	PTO MAG
- 30°C - 20°F		←	←	←	←	←	←	PTO MAG
- 20°C - 4°F		310 310	310 310	310 310	310 310	310 310	310 310	PTO MAG
- 10°C 14°F		←	←	←	←	←	←	PTO MAG
0°C 32°F		←	←	←	←	←	←	PTO MAG
10°C 50°F		←	←	←	←	←	←	PTO MAG
20°C 70°F		←	←	←	←	←	←	PTO MAG

**NOTE:** Arrows in the charts indicate that the preceding information is repeated.



 **WARNING**

For safety reasons, this kit must be installed by an authorized Bombardier snowmobile dealer. Should removal of a locking device be required when undergoing disassembly/assembly, always replace with a new one. This instruction sheet should be given to the purchaser. This kit is designed for specific models. It is not recommended for vehicles other than those for which it was sold.

 **CAUTION**

The following modifications and adjustments apply only for altitudes above 600 m (2000 ft).

**NOTE:** Installation time is approximately 1.5 hours.

**IMPORTANT:** Do not use the informations received previously.

## MODIFICATIONS AND ADJUSTMENTS

The transmission and carburation charts list all parts as well as modifications and adjustments needed for altitude and/or temperature changes.

*High Altitude Technical Data* sheets (P/N 484 300 003) containing technical information pertaining to carburetor jetting, transmission calibration, conversion charts and more, are available. They cover all models for the last 5 years. A convenient binder (P/N 484 054 500) can be ordered to organize the set.

## CARBURETOR JETTING

Stock vehicle jetting and the main jets included in this kit are prescribed for a temperature of - 20°C (- 4°F), as indicated by **bold face type** on the main jet chart. Snowmobile utilization above or below this temperature requires a different jetting. In that case, find the required main jet size in "Carburation" chart and order it according to the Bombardier P/N (part numbers) given in "Main Jet" P/N chart that can be found in the previously mentioned *High Altitude Technical Data* sheets.

# PARTS TO BE INSTALLED

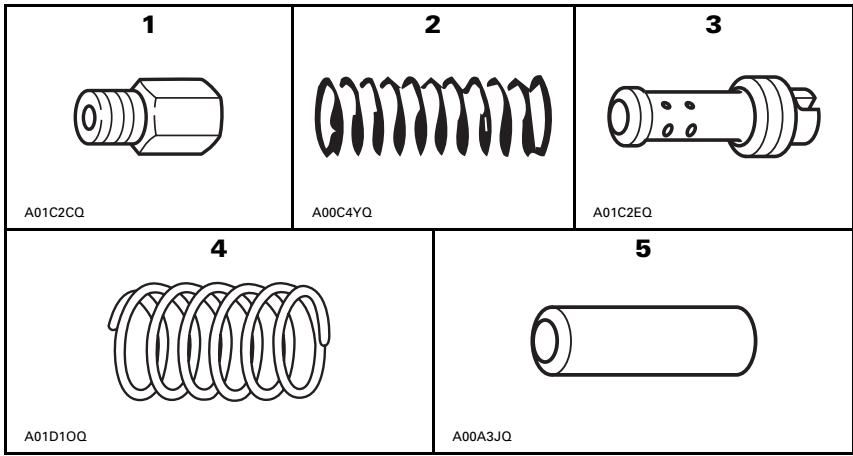

- |    |             |                    |     |     |
|----|-------------|--------------------|-----|-----|
| 1. | 404 100 400 | Main Jet           | 270 | (2) |
|    | 404 100 300 | Main Jet           | 250 | (2) |
|    | 404 118 900 | Main Jet           | 230 | (2) |
|    | 404 111 200 | Main Jet           | 220 | (2) |
|    | 404 119 100 | Main Jet           | 210 | (2) |
| 2. | 420 239 944 | Rave Valve Springs |     | (2) |
| 3. | 404 109 400 | Pilot Jet          | 45  | (2) |
| 4. | 414 639 000 | Spring             |     | (1) |
| 5. | 417 004 309 | Pin                |     | (3) |

# 1999-MX Z 600

## HIGH ALTITUDE KIT (P/N 861 767 700)

### DRIVE PULLEY

Altitude Clutching		Sea Level	600 m 2000 ft	1200 m 4000 ft	1800 m 6000 ft	2400 m 8000 ft	3000 m 10000 ft
Spring		Violet/Yellow 415 015 300	←	←	Blue/Orange 414 639 000	←	←
Ramp		Qty 3 x 1 417 005 281	←	←	←	←	←
Calibration screw position		3	4	5	3	4	5
Pin		Qty 3 x 1 417 004 308	←	←	Qty 3 x 1 417 004 309	←	←
Engagement RPM ± 100		3800	←	←	←	←	←
Maximum RPM ± 100		8000	←	←	←	←	←

### DRIVEN PULLEY

Altitude Clutching		Sea Level	600 m 2000 ft	1200 m 4000 ft	1800 m 6000 ft	2000 m 8000 ft	3000 m 10000 ft
Spring		Beige 414 558 900	←	←	←	←	←
Spring tension	Kg ± 0.7 lb ± 1.5	7.0 15.4	←	←	←	←	←
Cam angle	° (degrees)	50° 417 126 343	←	←	←	←	←

**NOTE:** Arrows in the charts indicate that the preceding information is repeated.

**Recommendation:** From 2400 m (8000 ft) and above, or in deep snow, install a large 22 teeth sprocket (P/N 504 083 500) to set chain case ratio to 23/43 whit 70 links chain.

# 1999-MX Z 600

## ▼ CAUTION

These adjustments are guidelines only. Specific adjustments vary with temperature, altitude and snow conditions. Always observe spark plug condition for proper jetting.

### CARBURATION

Altitude		Sea Level	600 m 2000 ft	1200 m 4000 ft	1800 m 6000 ft	2400 m 8000 ft	3000 m 10000 ft	Qty
Calibration								
Main jet		280 280	270 270	250 250	230 230	220 220	210 210	PTO MAG
Jet needle		7DfY1	←	←	←	←	←	2
Needle position		3	←	←	2	←	←	—
Slide cut-away		2.5	←	←	←	←	←	2
Pilot jet		37.5	←	←	45	←	←	2
Air screw		0.5	←	←	←	←	←	—
Valve seat		1.5 (V)	←	←	←	←	←	2
Needle jet		Z-9 (224)	←	←	←	←	←	2
Float level	mm	22.9	←	←	←	←	←	—
Idle	RPM ± 200	1600	←	←	←	←	←	—
Idle throttle valve position	mm	1.3	1.4	1.5	1.7	1.8	1.9	—

### MAIN JET CHART

Altitude		Sea Level	600 m 2000 ft	1200 m 4000 ft	1800 m 6000 ft	2400 m 8000 ft	3000 m 10000 ft	
Temperature								
- 40°C - 40°F		300 300	290 290	270 270	250 250	240 240	230 230	PTO MAG
- 30°C - 20°F		290 290	280 280	260 260	240 240	230 230	220 220	PTO MAG
<b>- 20°C - 4°F</b>		<b>280 280</b>	<b>270 270</b>	<b>250 250</b>	<b>230 230</b>	<b>220 220</b>	<b>210 210</b>	<b>PTO MAG</b>
- 10°C 14°F		270 270	260 260	240 240	220 220	210 210	205 205	PTO MAG
0°C 32°F		260 260	250 250	230 230	210 210	205 205	200 200	PTO MAG
10°C 50°F		250 250	240 240	220 220	205 205	200 200	195 195	PTO MAG
20°C 70°F		240 240	230 230	210 210	200 200	195 195	190 190	PTO MAG

**NOTE:** Arrows in the charts indicate that the preceding information is repeated.



 **WARNING**

For safety reasons, this kit must be installed by an authorized Bombardier snowmobile dealer. Should removal of a locking device be required when undergoing disassembly/assembly, always replace with a new one. This instruction sheet should be given to the purchaser. This kit is designed for specific models. It is not recommended for vehicles other than those for which it was sold.

 **CAUTION**

The following modifications and adjustments apply only for altitudes above 600 m (2000 ft).

NOTE: Installation time is approximately 1.5 hours.

## MODIFICATIONS AND ADJUSTMENTS

The transmission and carburation charts list all parts as well as modifications and adjustments needed for altitude and/or temperature changes.

*High Altitude Technical Data* sheets (P/N 484 300 003) containing technical information pertaining to carburetor jetting, transmission calibration, conversion charts and more, are available. They cover all models for the last 5 years. A convenient binder (P/N 484 054 500) can be ordered to organize the set.

## CARBURETOR JETTING

Stock vehicle jetting and the main jets included in this kit are prescribed for a temperature of - 20°C (- 4°F), as indicated by **bold face type** on the main jet chart. Snowmobile utilization above or below this temperature requires a different jetting. In that case, find the required main jet size in "Carburation" chart and order it according to the Bombardier P/N (part numbers) given in "Main Jet" P/N chart that can be found in the previously mentioned *High Altitude Technical Data* sheets.

# PARTS TO BE INSTALLED

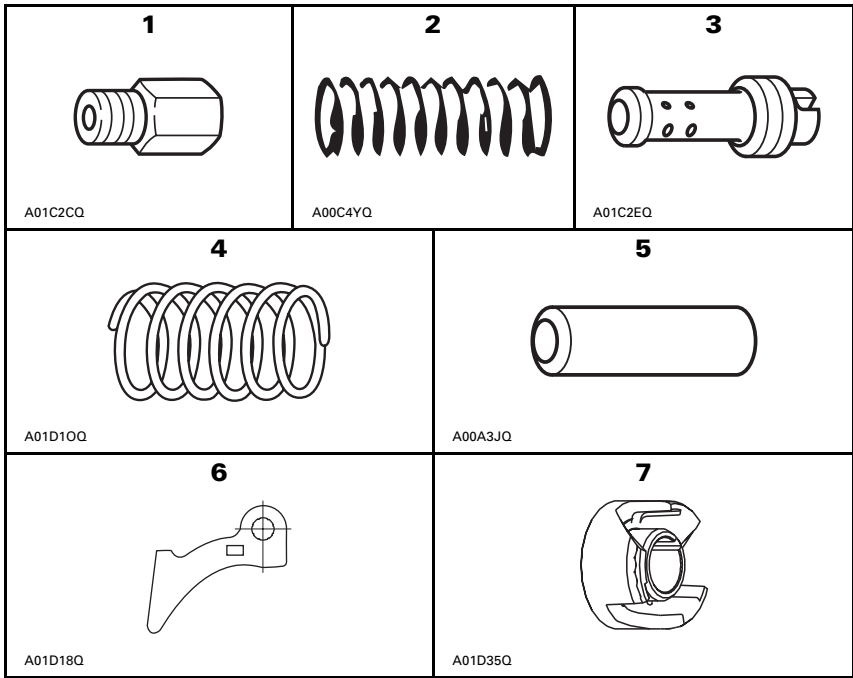

- |    |             |                    |     |     |
|----|-------------|--------------------|-----|-----|
| 1. | 404 100 400 | Main Jet           | 270 | (2) |
|    | 404 100 300 | Main Jet           | 250 | (2) |
|    | 404 118 900 | Main Jet           | 230 | (2) |
|    | 404 111 200 | Main Jet           | 220 | (2) |
|    | 404 119 100 | Main Jet           | 210 | (2) |
| 2. | 420 239 944 | Rave Valve Springs |     | (2) |
| 3. | 404 109 400 | Pilot Jet          | 45  | (2) |
| 4. | 414 768 200 | Spring             |     | (1) |
| 5. | 417 004 309 | Pin                |     | (3) |
| 6. | 417 005 294 | Ramp               |     | (3) |
| 7. | 417 126 337 | Cam 47°            |     | (1) |

# 1999-MX Z 600

## HIGH ALTITUDE KIT (High Performance)

(P/N 861 772 900)

### DRIVE PULLEY

Altitude Clutching		Sea Level	600 m 2000 ft	1200 m 4000 ft	1800 m 6000 ft	2400 m 8000 ft	3000 m 10000 ft
Spring		Violet/Yellow 415 015 300	←	Green/Blue 414 768 200	←	←	←
Ramp		Qty 3 x 1 417 005 281	←	Qty 3 x 1 417 005 294	←	←	←
Calibration screw position		3	4	3	<u>4</u>	<u>5</u>	<u>6</u>
Pin		Qty 3 x 1 417 004 308	←	Qty 3 x 1 417 004 309	←	←	←
Engagement RPM ± 100		3800	←	<u>4200</u>	←	←	←
Maximum RPM ± 100		8000	←	←	←	←	←

### DRIVEN PULLEY

Altitude Clutching		Sea Level	600 m 2000 ft	1200 m 4000 ft	1800 m 6000 ft	2000 m 8000 ft	3000 m 10000 ft
Spring		Beige 414 558 900	←	←	←	←	←
Spring tension	Kg ± 0.7 lb ± 1.5	7.0 15.4	←	←	←	←	←
Cam angle	° (degrees)	50° 417 126 343	←	47° 417 126 337	←	←	←

**NOTE:** Arrows in the charts indicate that the preceding information is repeated.

**Recommendation:** From 2400 m (8000 ft) and above, or in deep snow, install a large 23 teeth sprocket (P/N 504 085 400) to set chain case ratio to 23/43.



# 1999-MX Z 600

## ▼ CAUTION

These adjustments are guidelines only. Specific adjustments vary with temperature, altitude and snow conditions. Always observe spark plug condition for proper jetting.

### CARBURATION

Altitude		Sea Level	600 m 2000 ft	1200 m 4000 ft	1800 m 6000 ft	2400 m 8000 ft	3000 m 10000 ft	Qty
Calibration								
Main jet		280 280	270 270	250 250	230 230	220 220	210 210	PTO MAG
Jet needle		7DfY1	←	←	←	←	←	2
Needle position		3	←	←	2	←	←	—
Slide cut-away		2.5	←	←	←	←	←	2
Pilot jet		37.5	←	←	45	←	←	2
Air screw		0.5	←	←	←	←	←	—
Valve seat		1.5 (V)	←	←	←	←	←	2
Needle jet		Z-9 (224)	←	←	←	←	←	2
Float level	mm	22.9	←	←	←	←	←	—
Idle	RPM ± 200	1600	←	←	←	←	←	—
Idle throttle valve position	mm	1.3	1.4	1.5	1.7	1.8	1.9	—

### MAIN JET CHART

Altitude		Sea Level	600 m 2000 ft	1200 m 4000 ft	1800 m 6000 ft	2400 m 8000 ft	3000 m 10000 ft	
Temperature								
- 40°C - 40°F		300 300	290 290	270 270	250 250	240 240	230 230	PTO MAG
- 30°C - 20°F		290 290	280 280	260 260	240 240	230 230	220 220	PTO MAG
<b>- 20°C - 4°F</b>		<b>280 280</b>	<b>270 270</b>	<b>250 250</b>	<b>230 230</b>	<b>220 220</b>	<b>210 210</b>	<b>PTO MAG</b>
- 10°C 14°F		270 270	260 260	240 240	220 220	210 210	205 205	PTO MAG
0°C 32°F		260 260	250 250	230 230	210 210	205 205	200 200	PTO MAG
10°C 50°F		250 250	240 240	220 220	205 205	200 200	195 195	PTO MAG
20°C 70°F		240 240	230 230	210 210	200 200	195 195	190 190	PTO MAG

**NOTE:** Arrows in the charts indicate that the preceding information is repeated.



 **WARNING**

For safety reasons, this kit must be installed by an authorized Bombardier snowmobile dealer. Should removal of a locking device be required when undergoing disassembly/assembly, always replace with a new one. This instruction sheet should be given to the purchaser. This kit is designed for specific models. It is not recommended for vehicles other than those for which it was sold.

 **CAUTION**

The following modifications and adjustments apply only for altitudes from and below 1800 m (6 000 ft).

**Failure to comply with this kit requirements at altitudes from and below 1800 m (6 000 ft) may cause serious engine damage.**

NOTE: Installation time is approximately 1.5 hours.

## MODIFICATIONS AND ADJUSTMENTS

The transmission and carburation charts list all parts as well as modifications and adjustments needed for altitude and/or temperature changes.

*High Altitude and Sea Level Technical Data* sheets (P/N 484 300 003) containing technical information pertaining to carburetor jetting, transmission calibration, conversion charts and more, are available. They cover all models for the last 5 years. A convenient binder (P/N 484 054 500) can be ordered to organize the set.

## CARBURETOR JETTING

Stock vehicle jetting and the main jets included in this kit are prescribed for a temperature of -20°C (-4°F), as indicated by **bold face type** on the main jet chart. Snowmobile utilization above or below this temperature requires a different jetting. In that case, find the required main jet size in "Carburation" chart and order it according to the Bombardier P/N (part numbers) given in "Main Jet" P/N chart that can be found in the previously mentioned *High Altitude Technical Data* sheets.

# PARTS TO BE INSTALLED

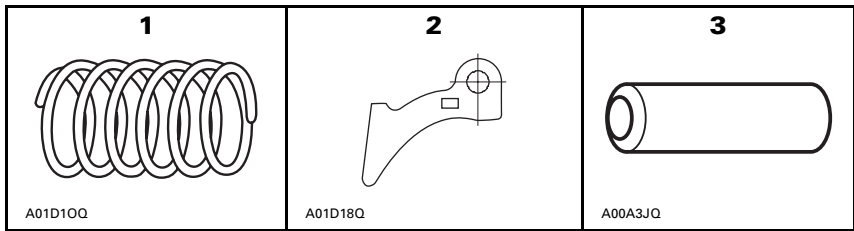

- |    |             |        |               |     |
|----|-------------|--------|---------------|-----|
| 1. | 414 817 900 | Spring | Violet/Violet | (1) |
| 2. | 417 005 286 | Ramp   |               | (3) |
| 3. | 417 004 308 | Pin    |               | (3) |

# 1999-SUMMIT X 670

## SEA LEVEL KIT (P/N 861 770 800)

### DRIVE PULLEY

Altitude Clutching		Sea Level	600 m 2000 ft	1200 m 4000 ft	1800 m 6000 ft	2400 m 8000 ft	3000 m 10000 ft
Spring		←	Violet/Violet 414 817 900	←	←	Violet/Yellow 415 015 300	←
Ramp		←	417 005 286	←	←	417 005 287	←
Calibration screw position		3	4	3	4	5	6
Pin		←	417 004 308	←	←	417 004 309	←
Engagement RPM ± 100		←	3800	←	←	4100	←
Maximum RPM ± 100		←	←	←	←	8000	←

### DRIVEN PULLEY

Altitude Clutching		Sea Level	600 m 2000 ft	1200 m 4000 ft	1800 m 6000 ft	2000 m 8000 ft	3000 m 10000 ft
Spring		←	←	←	←	Beige 414 558 900	←
Spring tension	Kg ± 0.7 lb ± 1.5	←	←	←	←	7.0 15.4	←
Cam angle	° (degrees)	←	←	←	←	47 417 126 337	←

**Recommendation:** At sea level, chaincase ratio: 23/43, sprocket 23 teeth, large, (P/N 504 085 400).

# 1999-SUMMIT X 670

## ▼ CAUTION

These adjustments are guidelines only. Specific adjustments vary with temperature, altitude and snow conditions. Always observe spark plug condition for proper jetting.

### CARBURATION

Altitude		Sea Level	600 m 2000 ft	1200 m 4000 ft	1800 m 6000 ft	2400 m 8000 ft	3000 m 10000 ft	Qty
Calibration								
Main jet		350 340	350 340	350 340	350 340	350 340	350 340	PTO MAG
Jet needle		←	←	←	←	7ECY1		2
Needle position		←	←	←	←	2	←	—
Slide cut-away		←	←	←	←	2.5	←	2
Pilot jet		←	←	←	←	55	←	2
Air screw		←	←	←	←	1.75	←	—
Valve seat		←	←	←	←	1.5	←	2
Needle jet		←	←	←	←	AA-8 (224)	←	2
Float level	mm	←	←	←	←	22.9	←	—
Idle	RPM ± 200	←	←	←	←	1700	←	—
Idle throttle valve position	mm	1.90	2.10	2.20	2.30	2.40	2.50	—

### MAIN JET CHART

Altitude		Sea Level	600 m 2000 ft	1200 m 4000 ft	1800 m 6000 ft	2400 m 8000 ft	3000 m 10000 ft	
Temperature								
- 40°C - 40°F		370 360	←	←	←	←	←	PTO MAG
- 30°C - 20°F		360 350	←	←	←	←	←	PTO MAG
- 20°C - 4°F		350 340	←	←	←	←	←	<b>PTO MAG</b>
- 10°C 14°F		350 340	←	←	←	←	←	PTO MAG
0°C 32°F		350 340	←	←	←	←	←	PTO MAG
10°C 50°F		350 340	←	←	←	←	←	PTO MAG
20°C 70°F		350 340	←	←	←	←	←	PTO MAG



 **WARNING**

For safety reasons, this kit must be installed by an authorized Bombardier snowmobile dealer. Should removal of a locking device be required when undergoing disassembly/assembly, always replace with a new one. This instruction sheet should be given to the purchaser. This kit is designed for specific models. It is not recommended for vehicles other than those for which it was sold.

 **CAUTION**

The following modifications and adjustments apply only for altitudes from and below 1800 m (6 000 ft).

**Failure to comply with this kit requirements at altitudes from and below 1800 m (6 000 ft) may cause serious engine damage.**

NOTE: Installation time is approximately 1.5 hours.

## MODIFICATIONS AND ADJUSTMENTS

The transmission and carburation charts list all parts as well as modifications and adjustments needed for altitude and/or temperature changes.

*High Altitude and Sea Level Technical Data* sheets (P/N 484 300 003) containing technical information pertaining to carburetor jetting, transmission calibration, conversion charts and more, are available. They cover all models for the last 5 years. A convenient binder (P/N 484 054 500) can be ordered to organize the set.

## CARBURETOR JETTING

Stock vehicle jetting and the main jets included in this kit are prescribed for a temperature of - 20°C (- 4°F), as indicated by **bold face type** on the main jet chart. Snowmobile utilization above or below this temperature requires a different jetting. In that case, find the required main jet size in "Carburation" chart and order it according to the Bombardier P/N (part numbers) given in "Main Jet" P/N chart that can be found in the previously mentioned *High Altitude Technical Data* sheets.

# PARTS TO BE INSTALLED

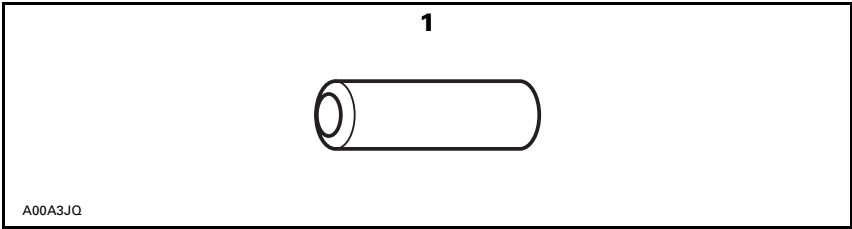

1. 417 004 308 Pin (3)

# 1999-SUMMIT 600/SUMMIT 500

## SEA LEVEL KIT (P/N 861 770 900)

### DRIVE PULLEY (Both Models)

Altitude Clutching	Sea Level	600 m 2000 ft	1200 m 4000 ft	1800 m 6000 ft	2400 m 8000 ft	3000 m 10000 ft
	Spring	←	←	←	←	Green/Blue 414 768 200
Ramp	←	←	←	←	417 005 294	←
Pin	←	Qty 3 x 1 417 004 308	←	←	Qty 3 x 1 417 004 309	←
Engagement RPM ± 100	←	4000	←	←	4200	←

### Summit 600 only

Calibration screw position	4	5	3	4	5	6
Maximum RPM ± 100	←	←	←	←	8000	←

### Summit 500 only

Calibration screw position	3	4	2	3	4	5
Maximum RPM ± 100	←	←	←	←	7800	←

### DRIVEN PULLEY (Both Models)

Altitude Clutching	Sea Level	600 m 2000 ft	1200 m 4000 ft	1800 m 6000 ft	2000 m 8000 ft	3000 m 10000 ft
	Spring	←	←	←	←	Beige 414 558 900
Spring tension	Kg ± 0.7 lb ± 1.5	←	←	←	7.0 15.4	←

### Summit 600 only

Cam angle	° (degrees)	←	←	←	←	47 417 126 337	←
--------------	----------------	---	---	---	---	-------------------	---

### Summit 500 only

Cam angle	° (degrees)	←	←	←	←	44 417 126 333	←
--------------	----------------	---	---	---	---	-------------------	---

**NOTE:** Arrows in the charts indicate that the preceding information is repeated.

**Additional Information:** On Summit 600, use a 23 teeth sprocket (P/N 504 085 400) at sea level to obtain a chain case ratio of 23/43.



# 1999-SUMMIT 600/SUMMIT 500

## ▼ CAUTION

These adjustments are guidelines only. Specific adjustments vary with temperature, altitude and snow conditions. Always observe spark plug condition for proper jetting.

### CARBURATION (Summit 600)

Altitude		Sea Level	600 m 2000 ft	1200 m 4000 ft	1800 m 6000 ft	2400 m 8000 ft	3000 m 10000 ft	Qty
Calibration								
Main jet		←	←	←	←	280	←	2
Jet needle		←	←	←	←	7DFY1	←	2
Needle position		←	←	←	←	3	←	—
Slide cut-away		←	←	←	←	2.5	←	2
Pilot jet		←	←	←	←	37.5	←	2
Air screw		←	←	←	←	0.5	←	2
Valve seat		←	←	←	←	1.5 (V)	←	2
Needle jet		←	←	←	←	Z-9 (224)	←	2
Float level	mm	←	←	←	←	22.9	←	—
Idle	RPM ± 200	←	←	←	←	1600	←	—
Idle throttle valve position	mm	←	←	←	←	1.7	←	—

### CARBURATION (Summit 500)

Altitude		Sea Level	600 m 2000 ft	1200 m 4000 ft	1800 m 6000 ft	2400 m 8000 ft	3000 m 10000 ft	Qty
Calibration								
Main jet		←	←	←	←	PTO 350 MAG 330	←	2
Jet needle		←	←	←	←	6DHY48	←	2
Needle position		←	←	←	←	4	←	—
Slide cut-away		←	←	←	←	2.5	←	2
Pilot jet		←	←	←	←	75	←	2
Air screw		←	←	←	←	2.00	←	2
Valve seat		←	←	←	←	1.5 (V)	←	2
Needle jet		←	←	←	←	Q-6 (480)	←	2
Float level	mm	←	←	←	←	18.1	←	—
Idle	RPM ± 200	←	←	←	←	1800	←	—
Idle throttle valve position	mm	←	←	←	←	2.2	←	—

# 1999-SUMMIT 600/SUMMIT 500

## MAIN JET CHART (Summit 600)

Altitude Temperature	Sea Level	600 m 2000 ft	1200 m 4000 ft	1800 m 6000 ft	2400 m 8000 ft	3000 m 10000 ft	Qty
- 40°C - 40°F	←	←	←	←	300	←	PTO MAG
- 30°C - 20°F	←	←	←	←	290	←	PTO MAG
- 20°C - 4°F	←	←	←	←	<b>280</b>	←	PTO MAG
- 10°C 14°F	←	←	←	←	280	←	PTO MAG
0°C 32°F	←	←	←	←	280	←	PTO MAG
10°C 50°F	←	←	←	←	280	←	PTO MAG
20°C 70°F	←	←	←	←	280	←	PTO MAG

## MAIN JET CHART (Summit 500)

Altitude Temperature	Sea Level	600 m 2000 ft	1200 m 4000 ft	1800 m 6000 ft	2400 m 8000 ft	3000 m 10000 ft	Qty
- 40°C - 40°F	←	←	←	←	350 330	←	PTO MAG
- 30°C - 20°F	←	←	←	←	350 330	←	PTO MAG
- 20°C - 4°F	←	←	←	←	<b>350</b> <b>330</b>	←	PTO MAG
- 10°C 14°F	←	←	←	←	350 330	←	PTO MAG
0°C 32°F	←	←	←	←	350 330	←	PTO MAG
10°C 50°F	←	←	←	←	350 330	←	PTO MAG
20°C 70°F	←	←	←	←	350 330	←	PTO MAG

**NOTE:** Arrows in the charts indicate that the preceding information is repeated.