

ski-doo®

FLAT RATE Time Schedule BARÈME DE TEMPS à taux fixe 2003

Volume 1

MINI Z
TUNDRA R
GRAND TOURING
380 F
LEGEND/MX Z
380 F
550 F
SKANDIC
440 F LT
SUMMIT
550 F
GRAND TOURING
550 F
SKANDIC WT/SWT
500 F Sport

Effective November 22th, 2002
En vigueur le 22 novembre 2002

™&® ARE TRADEMARKS AND ® ARE REGISTERED TRADEMARKS OF BOMBARDIER INC. OR ITS SUBSIDIARIES.
© 2002 BOMBARDIER INC. ALL RIGHTS RESERVED.
PRINTED IN CANADA

™&® SONT DES MARQUES DE COMMERCE ET ® SONT DES MARQUES DÉPOSÉES DE BOMBARDIER INC. OU SES FILIALES.
© 2002 BOMBARDIER INC. TOUS DROITS RÉSERVÉS.
IMPRIMÉ AU CANADA



INTRODUCTION

This publication governs all warranty labor allowances for 2003 Bombardier Snowmobiles.

1. HOW DOES IT WORK

We follow the procedures detailed in the Bombardier *Snowmobiles Shop Manual*. The flat rate time is the maximum time allowed for a repair involving any given part. **FLAT RATE TIME IS NOT CUMULATIVE.** You must use the flat rate time given for the longest lasting operation.

NOTE: The *Flat Rate Time Schedule* was prepared by skilled mechanics using the hand tool usually found in workshops and all the special tools mentioned in the *Shop Manual*.

2. COMPILATION

The *Flat Rate Time Schedule* is compiled as follows:

The actual required time to perform the repair plus (+) 30% correction factor up to 3.0 hours or (+) 15% over 3.0 hours time to take into account, among others:

- vehicle handling
- obtaining the parts
- diagnosis
- cleaning
- special compensation (rusted bolts).

3. HOW TO USE IT

Refer to the system you need, locate part of series of parts replaced. List JOB CODE in the appropriate column on claim.

SYSTEM		PAGE
01	ENGINE	4
02	CARBURETOR AND OIL INJECTION SYSTEM	12
03	IGNITION SYSTEM	16
04	STARTER	20
05	TRANSMISSION SYSTEM	22

SYSTEM		PAGE
06	BRAKE SYSTEM	32
07	STEERING SYSTEM AND FRONT SUSPENSION	36
08	REAR SUSPENSION AND TRACK	43
09	BODY	52
10	ELECTRICAL SYSTEM	55

NOTE: Unless otherwise specified, dismantling order is: top to bottom, exterior to interior, front to rear.

All fractions of hours are in tenths:

- 0.1 = 6 minutes
- 0.2 = 12 minutes, and so on

LEGEND:

- * REQUIRES PRIOR AUTHORIZATION BY DISTRIBUTOR.
- ** INDICATE LABOUR TIME ON LINE "LABOUR ONLY" OF CLAIM.
- *** INDICATE \$\$\$ AMOUNT ON "SUB-CONTRACTED LABOUR" OF CLAIM.

IMPORTANT: Always use the longest flat rate time applicable to the repair performed.

4. JOB REQUIREMENTS

All the flat rate times mentioned in the following pages include the required operations such as: engine timing (rotary valve and ignition), connecting rod(s) alignment, cylinder head(s) torque or use of parallel bar, use of ignition tester, piston clearance/ring end gap measurement, crankshaft to crankcase measurement, cylinder honing, engine leak test.

5. ILLUSTRATIONS

The illustrations contained in this manual do not necessarily show every components of a given system as *Parts Catalog* do. Their purpose is to facilitate recognition of parts related to a flat rate time. **Item numbers on illustrations correspond to the four digit Job Code.**

6. SUGGESTION (form request)

INTRODUCTION

Cette publication détermine le temps de main d'oeuvre couvert par la garantie pour les motoneiges Bombardier 2003.

1. UTILISATION DU MANUEL

En procédant de la façon indiquée dans le *Manuel de réparation motoneiges* Bombardier, chaque temps donné représente le maximum permis pour une réparation portant sur cette pièce. **LES TEMPS NE SONT PAS CUMULATIFS.** On doit inscrire le temps donné pour l'opération qui prend le plus de temps.

REMARQUE: Le *Barème de temps à taux fixe* a été préparé par des mécaniciens compétents utilisant les outils que l'on retrouve normalement dans les ateliers de réparation, en plus de tous les outils spéciaux mentionnés dans le *Manuel de réparation*.

2. COMPILATION

Le *Barème de temps à taux fixe* a été établi en compilant le temps nécessaire pour faire la réparation plus (+) un facteur de correction de 30% lorsqu'un travail dure 3.0 heures et moins, ou (+) 15% lorsqu'un travail dure plus de 3.0 heures. Cette compilation comprends, entre autres les étapes suivantes:

- manutention du véhicule
- nettoyage
- aller chercher les pièces, essais physique
- compensation spéciale (boulons rouillés)
- diagnostic.

3. UTILISATION DU BARÈME

Se reporter à la section désirée, repérer la pièce ou l'ensemble de pièces remplacées et inscrire le CODE DE TRAVAIL dans la colonne appropriée sur la formule de réclamation.

SYSTÈME		PAGE
01	MOTEUR	4
02	CARBURATEUR ET SYSTÈME D'INJECTION D'HUILE	12
03	SYSTÈME D'ALLUMAGE	16
04	DÉMARREUR	20
05	SYSTÈME DE TRANSMISSION	22

SYSTÈME		PAGE
06	SYSTÈME DE FREIN	32
07	SYSTÈME DE DIRECTION ET SUSPENSION AVANT	36
08	SUSPENSION ARRIÈRE ET CHENILLE	43
09	CARROSSERIE	52
10	SYSTÈME ÉLECTRIQUE	55

REMARQUE: Sauf indication contraire, le démontage doit s'effectuer de haut en bas, de l'extérieur vers l'intérieur, de l'avant vers l'arrière.

Toutes les fractions d'heures sont exprimées en dixièmes:

0.1 = 6 minutes

0.2 = 12 minutes, et ainsi de suite

LÉGENDE:

* AUTORISATION REQUISE AVANT LE REMPLACEMENT.

** INSCRIRE LE TEMPS À LA LIGNE «MAIN D'OEUVRE SEULEMENT».

*** INSCRIRE LE MONTANT \$\$\$ À LA LIGNE «OUVRAGE SOUS-CONTRACTÉE».

IMPORTANT: Toujours utiliser le temps donné à l'opération qui nécessite le plus de temps.

4. TRAVAUX REQUIS

Tous les temps mentionnés dans les pages suivantes incluent les opérations telles que: réglage du moteur (valve rotative et allumage), alignement de la ou des bielles, couple de serrage de la ou des culasses ou l'utilisation de barres parallèles, utilisation du vérificateur d'allumage, mesure du jet des pistons/jeu en bout des segments, mesure de l'écart entre le vilebrequin et le carter, rectification du cylindre, vérification de fuite du moteur.

5. ILLUSTRATIONS

Contrairement aux *Catalogues de pièces*, les illustrations de ce manuel ne montrent pas nécessairement chacune des pièces qu'elles représentent, leur raison d'être étant plutôt de faciliter la reconnaissance des pièces reliées à un barème de temps à taux fixe. **Les numéros d'items sur les illustrations correspondent aux quatre derniers chiffres du code de travail.**

6. SUGGESTION DE CHANGEMENT (formulaire)

2003

FAN COOLED MODELS/MODÈLES REFROIDIS PAR AIR

TABLE	DESCRIPTION	MODEL/MODÈLE	ENGINE/MOTEUR	CHASSIS TYPE/ TYPE DE CHÂSSIS	REVERSE/ MARCHE ARRIÈRE	REAR SUSPENSION/ SUSPENSION ARR.	ELECT. STARTER/ DÉMARREUR ÉLECT.	DRIVE PULLEY/ POULIE MOTRICE	DRIVEN PULLEY/ POULIE MÈNÉE
1	Mini Z (CDN/US)	2647	120	MINI Z	-	-	-	-	-
2	Tundra R (CDN/US)	3279/3280	277	Tundra	R.E.R	Torque Reaction	-	Bomb Lite	Tundra
3	Grand Touring 380F (CDN/US)	2445/2446	377	ZX	R.E.R	SC-10 LT	Std	Bomb Lite	Formula RER
	Grand Touring 380F (EUR)	2628							
4	Legend 380F (CDN/US)	2370/2371	377	ZX	R.E.R	SC-10 Sport	Std	Bomb Lite	Formula RER
	MX Z 380F (CDN/US)	2366/2367	377	ZX	R.E.R	SC-10 Sport	Opt	Bomb Lite	Formula RER
	MX Z 380F (EUR)	2618							
5	Skandic 440F LT (CDN/US)	2573/2574 2634/2635	443	LT	R.E.R	Articul Slide	Opt	Comet 102c	Formula RER
6	Summit 550F (CDN/US)	2449/2450 2454/2455	552	ZX	R.E.R	Sc-10 Mountain	Opt	C.D T.R.A.C.	Formula RER
	Summit 550F (EUR)	2640							
7	Grand Touring 550F (CDN/US)	2443/2444 4046	552	ZX	R.E.R	SC-10 LT	Std	C.D T.R.A.C.	Formula RER
	Grand Touring 550F (EUR)	2627							
8	Legend 550F (CDN/US)	2368/2369	552	ZX	R.E.R	SC-10 Sport	Std	C.D T.R.A.C.	Formula RER
	MX Z 550F (CDN/US)	2364/2639	552	ZX	R.E.R	SC-10 Sport	Opt	C.D T.R.A.C.	Formula RER
	MX Z 550F (EUR)	2617							
9	Skandic 500F SWT (CDN/US)	2567/2568	503	SWT	MEC	Articul Slide	Std	C.D T.R.A.C.	T-Bushing
	Skandic 500F WT (CDN/US)	2571/2572	503	WT	MEC	Articul Slide	Std	C.D T.R.A.C.	T-Bushing
10	Skandic 500F Sport (CDN/US)	2447/2448	503	SWT	MEC	Articul Slide	Std	C.D T.R.A.C.	T-Bushing

01 ENGINE MOTEUR

SYSTEM/SYSTÈME

SYSTEM SYSTÈME	CODE	DESCRIPTION	MINI Z	TUNDRA R	GRAND TOURING 380 F	LEGEND 380 F MX Z 380 F	SKANDIC 440 FLT	SUMMIT 550 F	GRAND TOURING 550 F	LEGEND 500 F MX Z 550 F	SKANDIC 500 F WT/SWT	SKANDIC 500 F SPORT
			1	2	3	4	5	6	7	8	9	10

01	00	NO LABOR INVOLVED AUCUNE MAIN D'OEUVRE IMPLIQUÉE	0	0	0	0	0	0	0	0	0	0
01	01	REMOVE AND REPLACE ENGINE ASS'Y REPLACEMENT MOTEUR COMPLET	1.5	1.6	1.3	1.3	1.3	1.3	1.3	1.3	1.3	1.3
01	02	CYLINDER COWL (top) DÉFLECTEUR DE CYLINDRE (supérieur)		0.3	0.3	0.3	0.3	0.3	0.3	0.3	0.3	0.3
01	05	CYLINDER COWLS (bottom) DÉFLECTEURS DE CYLINDRE (inférieur)			0.9	0.9	0.9	0.9	0.9	0.9	0.9	0.9
01	06	FAN COWL HOUSING LOGEMENT DE VENTILATEUR		0.7	1.2	1.2	1.2	1.2	1.2	1.2	1.2	1.2
01	07	AIR DUCT AND/OR DEFLECTOR CONDUIT D'AIR ET/OU DÉFLECTEUR			0.3	0.3	0.3	0.3	0.3	0.3	0.3	0.3
01	08	FAN VENTILATEUR		0.3	0.3	0.3	0.3	0.3	0.3	0.3	0.3	0.3
01	09	FAN BEARING AND/OR SHAFT ROULEMENT ET/OU ARBRE DE VENTILATEUR		1.6	1.2	1.2	1.2	1.2	1.2	1.2	1.2	1.2
01	10	FAN BELT AND/OR PULLEY HALVES COURROIE ET/OU DEMI-POULIES VENTILATEUR		0.3	0.3	0.3	0.3	0.3	0.3	0.3	0.3	0.3
01	11	V-BELT PULLEY (cup) COURROIE EN V DE POULIE (cuvette)		0.3	0.3	0.3	0.3	0.3	0.3	0.3	0.3	0.3
01	12	CYLINDER HEAD COVER AND/OR GASKET COUVERCLE DE CULASSE ET/OU JOINT	1.8									
01	13	CYLINDER HEAD AND/OR GASKET (1) CULASSE ET/OU JOINT (1)		0.4	0.4	0.4	0.4	0.4	0.4	0.4	0.4	0.4
01	14	CYLINDER HEADS AND/OR GASKETS (2) CULASSES ET/OU JOINTS (2)			0.7	0.7	0.7	0.7	0.7	0.7	0.7	0.7
01	15	CYLINDER AND/OR GASKET (MAG) CYLINDRE ET/OU JOINT (MAG)			1.7	1.7	1.7	1.7	1.7	1.7	1.7	1.7
01	16	CYLINDER AND/OR GASKET (PTO) CYLINDRE ET/OU JOINT (PDM)			1.7	1.7	1.7	1.7	1.7	1.7	1.7	1.7
01	17	CYLINDERS AND/OR GASKETS (all) CYLINDRES ET/OU JOINTS (tous)		2.0	2.1	2.1	2.1	2.1	2.1	2.1	2.1	2.1
***		CYLINDER RESLEEVE CYLINDRE RÉUSINÉ										
01	25	PISTON, PIN, CIRCLIP, RING (MAG) PISTON, AXE, FREIN D'AXE, SEGMENTS (MAG)			2.5	2.5	2.5	2.5	2.5	2.5	2.5	2.5
01	26	PISTON, PIN, CIRCLIP, RING (PTO) PISTON, AXE, FREIN D'AXE, SEGMENTS (PDM)			2.5	2.5	2.5	2.5	2.5	2.5	2.5	2.5
01	27	PISTONS, PINS, CIRCLIPS, RINGS (MAG and PTO) PISTONS, AXES, FREINS, SEGMENTS (MAG et PDM)	1.9	2.3	2.7	2.7	2.7	2.7	2.7	2.7	2.7	2.7
01	28	INTAKE MANIFOLD AND/OR GASKET (1) TUBULURE D'ADMISSION ET/OU JOINT (1)		0.3	0.3	0.3	0.3				0.3	0.3

SYSTEM SYSTEME	CODE	DESCRIPTION	MINI Z	TUNDRA R	GRAND TOURING 380 F	LEGEND 380 F MX Z 380 F	SKANDIC 440 F LT	SUMMIT 550 F	GRAND TOURING 550 F	LEGEND 500 F MX Z 550 F	SKANDIC 500 F WT/SWT	SKANDIC 500 F SPORT
			1	2	3	4	5	6	7	8	9	10
01	29	INTAKE MANIFOLDS AND/OR GASKETS (2) TUBULURES D'ADMISSION ET/OU JOINTS (2)			0.4	0.4					0.4	0.4
01	31	CYLINDER STUD (MAG or PTO) (1) GOUJON DE CYLINDRE (MAG ou PDM) (1)			0.6	0.6	0.6	0.6	0.6	0.6	0.6	0.6
01	32	CYLINDER STUDS (MAG or PTO) (2) GOUJONS DE CYLINDRE (MAG ou PDM) (2)			0.7	0.7	0.7	0.7	0.7	0.7	0.7	0.7
01	33	CYLINDER STUDS (single cylinder) GOUJONS DE CYLINDRE (moteur monocylindre)		2.0								
01	39	FOUR STROKE OIL RESERVOIR RÉSERVOIR D'HUILE 4 TEMPS	3.2									
01	42	ENGINE BASE STUD (1) GOUJON DE BASE DE MOTEUR (1)			1.6	1.6	1.6	1.6	1.6	1.6	1.6	1.6
01	43	ENGINE BASE STUDS (2) GOUJONS DE BASE DE MOTEUR (2)			1.7	1.7	1.7	1.7	1.7	1.7	1.7	1.7
01	44	ENGINE RUBBER MOUNTS (3 or 4) TAMPONS D'ANCRAGE DE CAOUTCHOUC (3 ou 4)		0.4	0.4	0.4	0.4	0.4	0.4	0.4	1.5	0.4
01	45	ENGINE RUBBER MOUNTS SUPPORT (3 or 4) SUPPORTS DE TAMPONS D'ANCRAGE (3 ou 4)									1.6	
01	47	ENGINE SUPPORT SUPPORT DE MOTEUR		1.0	1.0	1.0	1.0	1.0	1.0	1.0	1.6	1.0
01	48	CRANKCASE REPLACE REPLACEMENT DU CARTER		3.5	5.3	5.3	5.3	5.3	5.3	5.3	5.3	5.3
01	49	CRANKCASE RESEAL AND/OR GASKET RECELLEMENT DU CARTER ET/OU JOINT		3.6	4.6	4.6	4.6	4.6	4.6	4.6	4.6	4.6
01	50	CRANKSHAFT AND/OR BEARINGS VILLEBREQUIN ET/OU ROULEMENT		4.0	5.3	5.3	5.3	5.3	5.3	5.3	5.3	5.3
01	51	CYLINDER HEAD GASKET JOINT DE CULASSE	2.2									
01	52	CYLINDER HEAD CULASSE	2.4									
01	53	ROCKER ARM OR VALVE ROCKER OR PUSH ROD (1) CULBUTEUR OU CULBUTEUR DE SOUPAPE OU TIGE DE CULBUTEUR (1)	1.6									
01	54	ROCKER ARMS OR VALVE ROCKER OR PUSH RODS (2) CULBUTEUR OU BRAS CULBUTEUR OU TIGE DE CULBUTEUR (2)	1.8									
01	55	CYLINDER/CRANKSHAFT ASS'Y ENSEMBLE CYLINDRE/VILEBREQUIN	3.3									

01 ENGINE MOTEUR

SYSTEM/SYSTÈME

SYSTEM SYSTÈME	CODE	DESCRIPTION	MINI Z	TUNDRA R	GRAND TOURING 380 F	LEGEND 380 F MX Z 380 F	SKANDIC 440 F LT	SUMMIT 550 F	GRAND TOURING 550 F	LEGEND 500 F MX Z 550 F	SKANDIC 500 F WT/SWT	SKANDIC 500 F SPORT
			1	2	3	4	5	6	7	8	9	10

01	56	CRANKCASE COVER GASKET JOINT DE COUVERCLE DE CARTER	1.8									
01	57	CRANKCASE COVER COUVERCLE DE CARTER	2.0									
01	58	INTAKE OR EXHAUST VALVE GUIDE (1) GUIDE DE SOUPEPE D'ADMISSION OU D'ÉCHAPPEMENT (1)	3.3									
01	59	INTAKE OR EXHAUST VALVE GUIDES (2) GUIDES DE SOUPEPE D'ADMISSION OU D'ÉCHAPPEMENT (2)	3.7									
01	60	VALVE AND/OR SPRING AND/OR SEAL RETAINER (1) SOUPEPE ET/OU RESSORT ET/OU JOINT DE RETENU (1)	2.3									
01	61	VALVES AND/OR SPRINGS AND/OR SEAL RETAINERS (2) SOUPAPES ET/OU RESSORTS ET/OU JOINTS DE RETENU (2)	2.4									
01	62	CAMSHAFT OR LIFTERS ARBRE À CAME OU POUSSOIRS HYDRAULIQUES	2.2									
01	63	CRANKSHAFT BEARING OUTPUT SIDE ROULEMENT DE VILEBREQUIN, CÔTÉ PDM	2.0									
01	64	CRANKSHAFT BEARING FLYWHEEL SIDE ROULEMENT DE VILEBREQUIN, CÔTÉ ROUE VOLANT	3.2									
01	65	CRANKSHAFT BEARINGS BOTH SIDES ROULEMENTS DE VILEBREQUIN, 2 CÔTÉS	3.6									
01	66	CRANKSHAFT OIL SEAL OUTPUT SIDE JOINT D'ÉTANCHEITÉ, CÔTÉ PDM	1.8									
01	67	CRANKSHAFT OIL SEAL FLYWHEEL SIDE JOINT D'ÉTANCHEITÉ, CÔTÉ ROUE VOLANT	2.0									
01	68	CRANKSHAFT OIL SEAL BOTH SIDES JOINT D'ÉTANCHEITÉ, 2 CÔTÉS	2.2									
01	69	CRANKSHAFT VILEBREQUIN	1.8									
***		CRANKSHAFT REBUILT VILEBREQUIN RÉUSINÉ										
01	70	MUFFLER SILENCIEUX	0.3									
01	71	EXHAUST MANIFOLD COLLECTEUR D'ÉCHAPPEMENT			0.3	0.3	0.3	0.3	0.3	0.3	0.3	0.3
01	75	MUFFLER/EXHAUST GROMMET/SUPPORT SILENCIEUX ET/OU BAGUE D'ÉCHAPPEMENT		0.3	0.3	0.3	0.3	0.3	0.3	0.3	0.3	0.3
01	77	ENGINE RUBBER MOUNTS (1 or 2) TAMPONS D'ANCRAGE DU MOTEUR (1 ou 2)		0.3	0.3	0.3	0.3	0.3	0.3	0.3	0.3	0.3

SYSTEM SYSTEME	CODE	DESCRIPTION	MINI Z	TUNDRA R	GRAND TOURING 380 F	LEGEND 380 F MX Z 380 F	SKANDIC 440 FLT	SUMMIT 550 F	GRAND TOURING 550 F	LEGEND 500 F MX Z 550 F	SKANDIC 500 F WT/SWT	SKANDIC 500 F SPORT
			1	2	3	4	5	6	7	8	9	10

01	80	REED VALVE ASS'Y AND/OR CARBURETOR SOCKET (1) SOUPAPE DE CLAPET COMPLÈTE ET/OU TUBULURE DU CARBURATEUR (1)							0.3	0.3		
01	81	REED VALVE ASS'Y AND/OR CARBURETOR SOCKET (2) SOUPAPE DE CLAPET COMPLÈTE ET/OU TUBULURE DU CARBURATEUR (2)							0.4	0.4		
01	89	EXHAUST GROMMET RONDELLE D'ÉCHAPPEMENT	0.4									

4 Strokes Engine Mini Z/Moteur 4 temps Mini Z

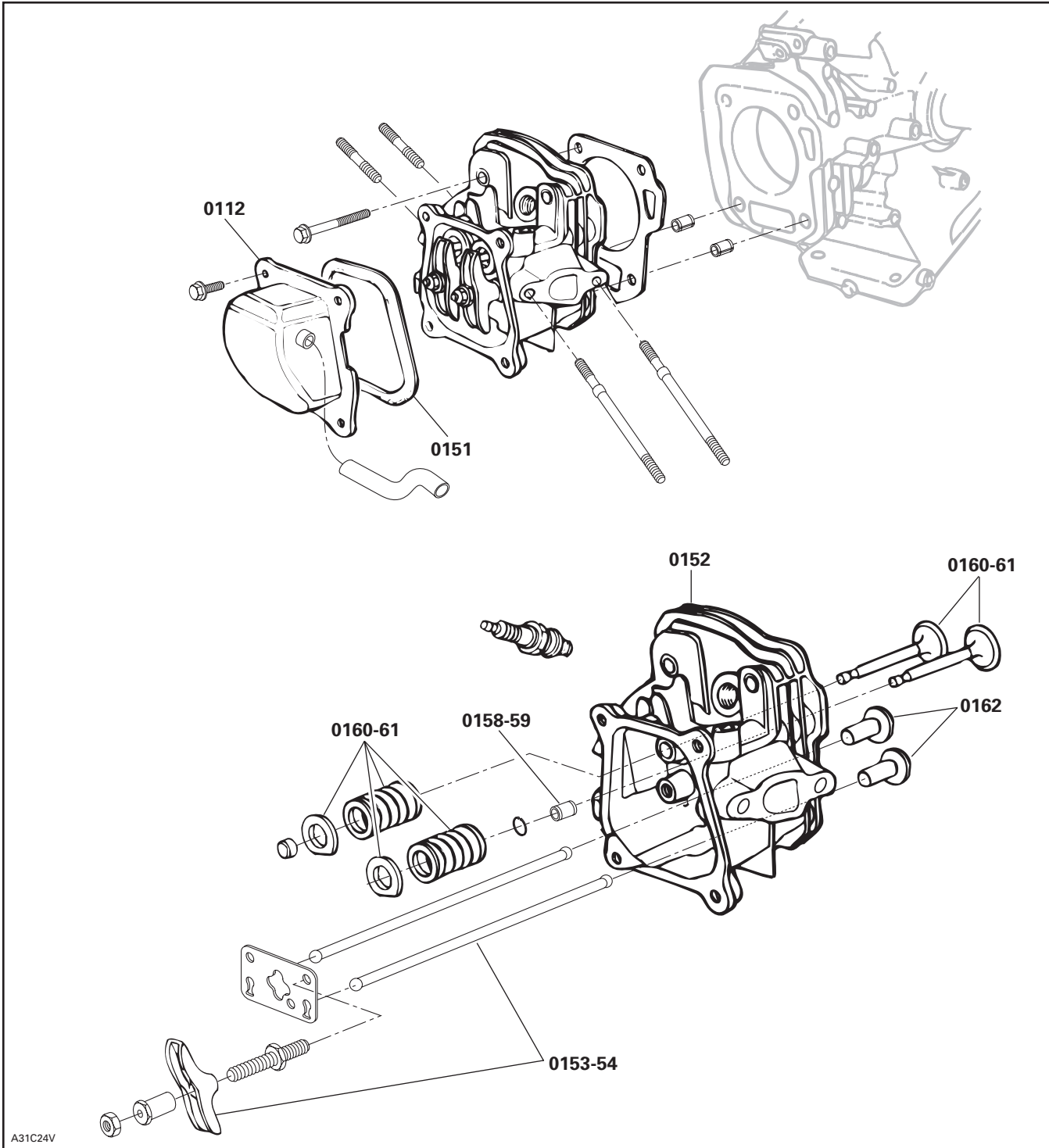

4 Strokes Engine Mini Z/Moteur 4 temps Mini Z

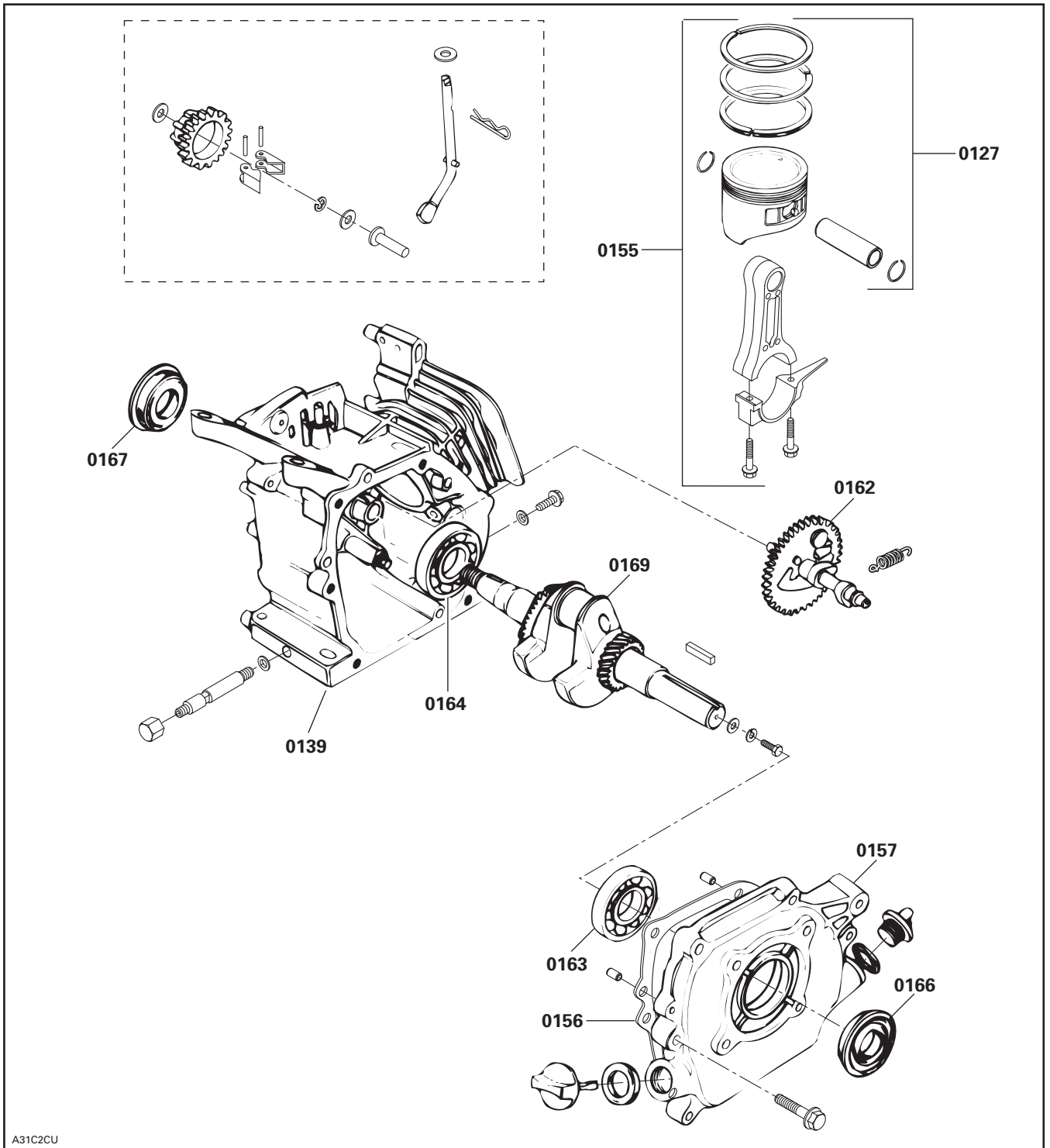

Tundra

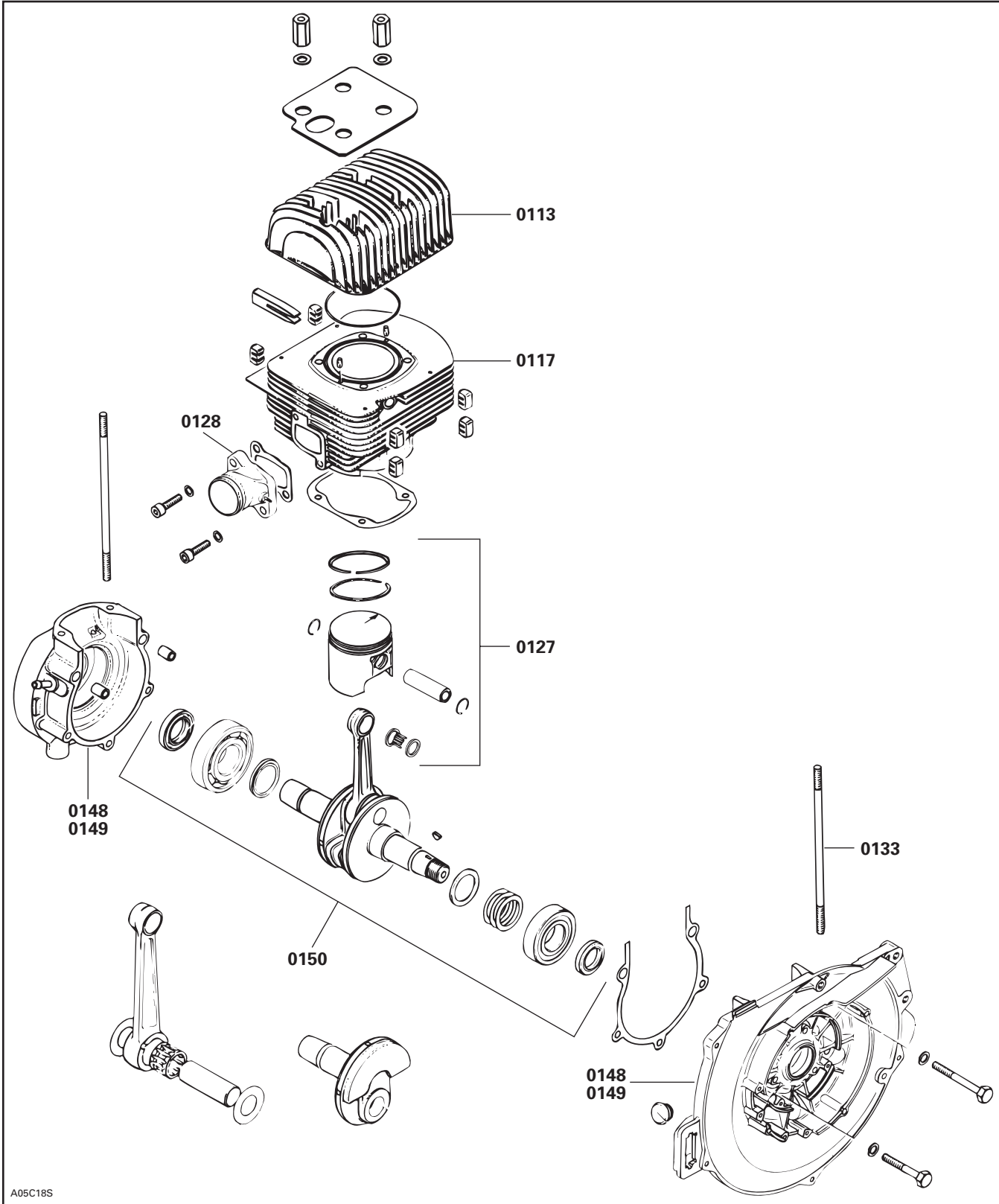

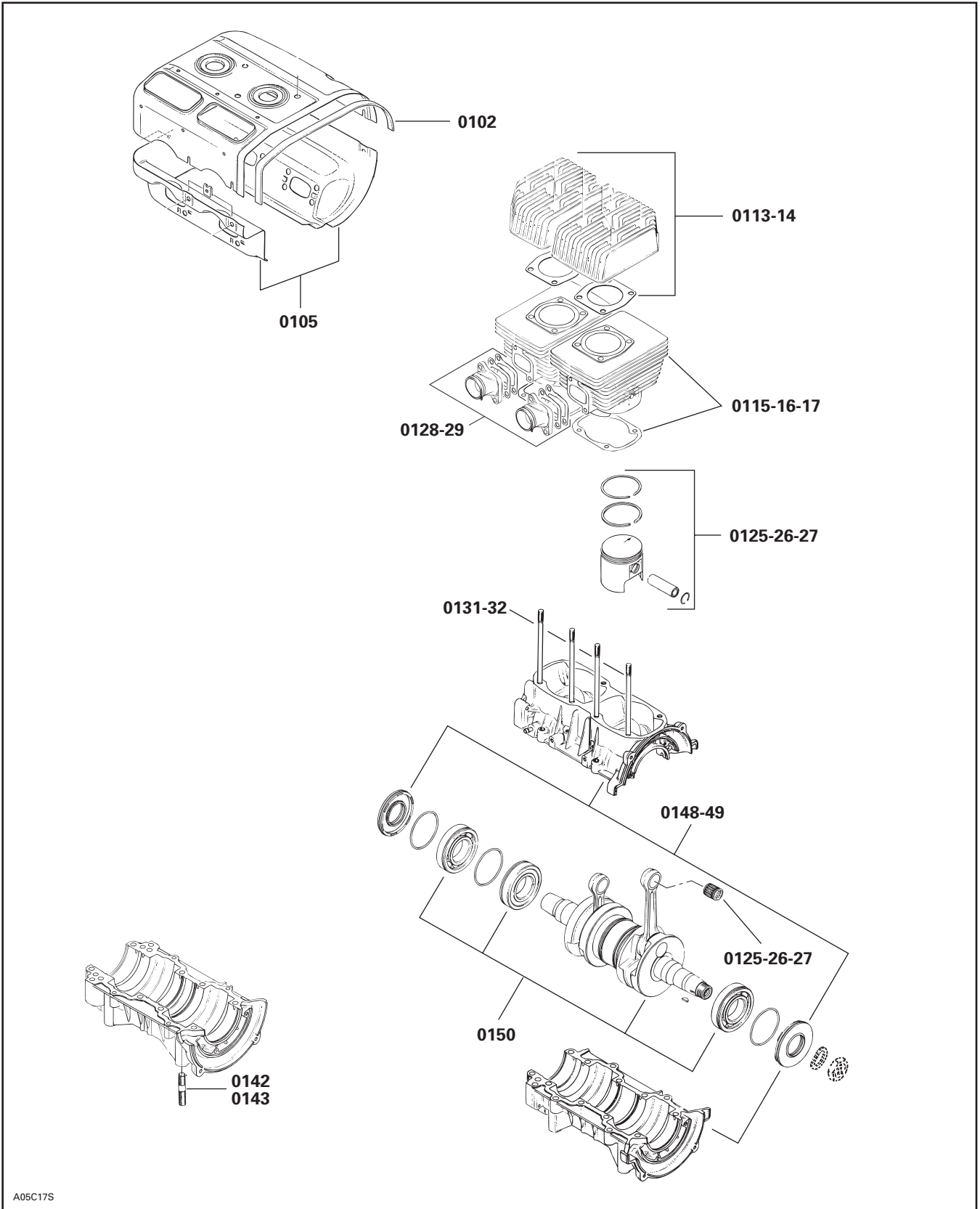

A05C17S

Engine Type 377-443-503/Type de moteur 377-443-503

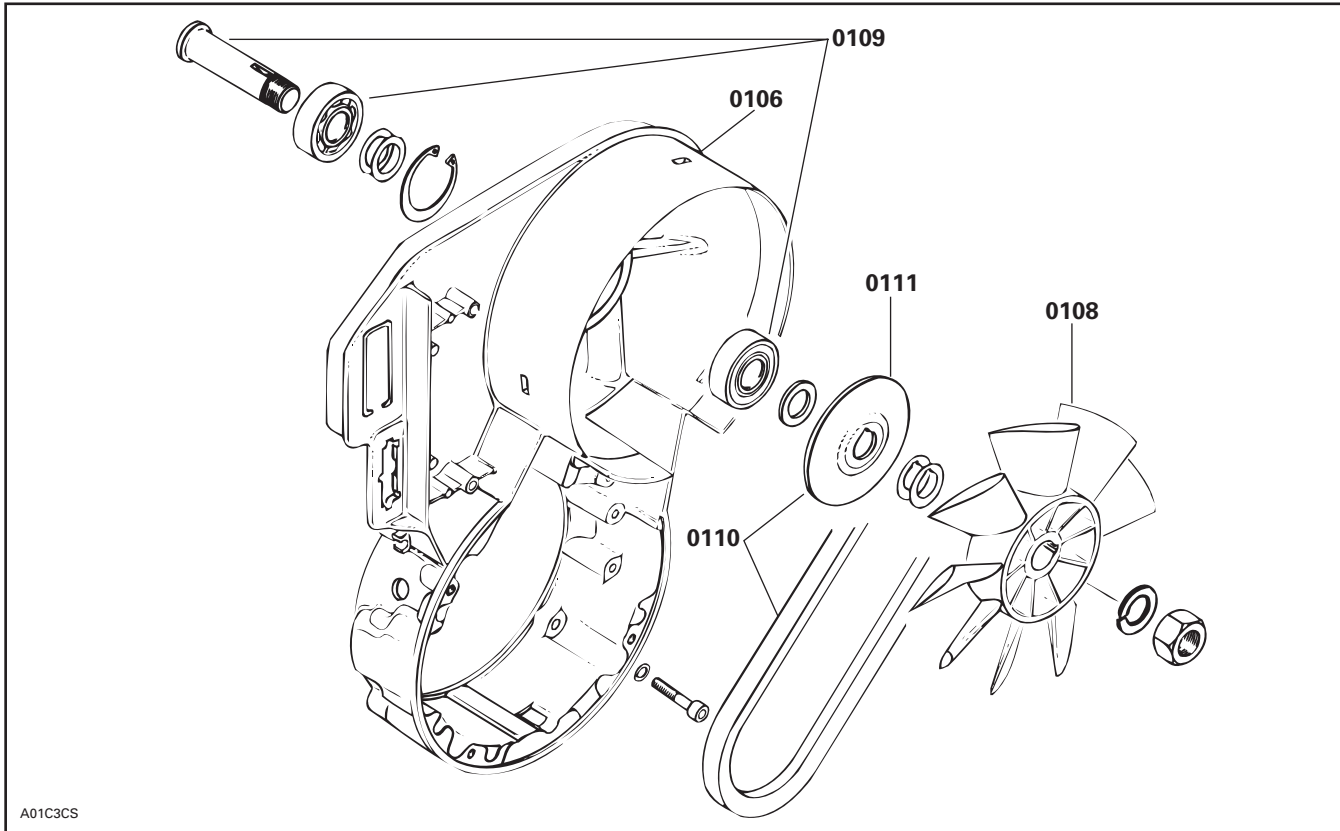

A01C3CS

CARBURETOR AND OIL INJECTION SYSTEM CARBURATEUR ET SYSTÈME D'INJECTION D'HUILE

SYSTEM SYSTÈME	CODE	DESCRIPTION	MINI Z	TUNDRA R	GRAND TOURING 380 F	LEGEND 380 F MX Z 380 F	SKANDIC 440 F LT	SUMMIT 550 F	GRAND TOURING 550 F	LEGEND 500 F MX Z 550 F	SKANDIC 500 F WT/SWT	SKANDIC 500 F SPORT
			1	2	3	4	5	6	7	8	9	10

02	00	NO LABOR INVOLVED AUCUNE MAIN-D'OEUVRE IMPLIQUÉE	0	0	0	0	0	0	0	0	0	0
02	01	AIR SILENCER ASS'Y (any/or all parts) SILENCIEUX D'ADMISSION (toutes pièces)		0.3	0.3	0.3	0.3	0.3	0.3	0.3	0.3	0.3
02	02	CARBURETOR ASS'Y (1) CARBURATEUR (1)	0.6	0.3	0.3	0.3	0.3	0.3	0.3	0.3	0.3	0.3
02	03	CARBURETORS ASS'Y (2) CARBURATEURS (2)			0.4	0.4		0.4	0.4	0.4	0.4	0.4
02	04	RUBBER FLANGE (1) BRIDE DE CAOUTCHOUC (1)		0.3	0.3	0.3	0.3	0.3	0.3	0.3	0.3	0.3
02	05	RUBBER FLANGES (2) BRIDES DE CAOUTCHOUC (2)			0.4	0.4		0.4	0.4	0.4		0.4
02	06	THROTTLE CABLE AND HOUSING CÂBLE DE GAINÉ D'ACCÉLÉRATEUR	0.3	0.3	0.3	0.3	0.3	0.3	0.3	0.3	0.3	0.3
02	08	OIL INJECTION PUMP POMPE À INJECTION D'HUILE		0.3	0.3	0.3	0.3	0.3	0.3	0.3	0.3	0.3
02	09	OIL INJECTION RESERVOIR RÉSERVOIR D'HUILE À INJECTION		0.3	0.3	0.3	0.3	0.3	0.3	0.3	0.3	0.3
02	10	FUEL PUMP POMPE À CARBURANT		0.3	0.3	0.3	0.3	0.3	0.3	0.3	0.3	0.3
02	11	FLOAT SYSTEM (any/or all parts) (1 carb) SYSTÈME DE FLOTTEUR (toutes pièces) (1 carb)		0.4	0.4	0.4	0.4	0.4	0.4	0.4	0.4	0.4
02	12	FLOAT SYSTEM (any/or all parts) (2 carbs) SYSTÈME DE FLOTTEUR (toutes pièces) (2 carbs)			0.7	0.7		0.7	0.7	0.7		0.7
02	13	JET NEEDLE, THROTTLE SLIDE (1) AIGUILLE DE GICLEUR, TIROIR D'ÉTRANGLEUR (1)		0.3	0.3	0.3	0.3	0.3	0.3	0.3	0.3	0.3
02	14	JET NEEDLES, THROTTLES SLIDES (2) AIGUILLES DE GICLEUR, TIROIRS (2)			0.4	0.4		0.4	0.4	0.4		0.4
**		CARBURETOR CLEANING AND REBUILDING (1) NETTOYAGE ET REMONTAGE DU CARBURATEUR (1)	0.8	0.5	0.5	0.5	0.5	0.5	0.5	0.5	0.5	0.5
**		CARBURETORS CLEANING AND REBUILDING (2) NETTOYAGE ET REMONTAGE DES CARBURATEURS (2)			0.9	0.9		0.9	0.9	0.9		0.9
02	17	MAIN JET, NEEDLE JET, PILOT JET (1) GICLEURS PRINCIPAL/AIGUILLE/RALENTI (1)	0.6	0.4	0.4	0.4	0.4	0.4	0.4	0.4	0.4	0.4
02	18	MAIN JETS, NEEDLE JETS, PILOT JETS (2) GICLEURS PRINCIPAUX/AIGUILLE/RALENTI (2)			0.6	0.6		0.6	0.6	0.6		0.6
02	24	OIL INJECTION FILTER FILTRE D'HUILE À INJECTION		0.3	0.3	0.3	0.3	0.3	0.3	0.3	0.3	0.3
02	25	OIL INJECTION LINE (1) BOYAU D'HUILE À INJECTION (1)		0.3	0.3	0.3	0.3	0.3	0.3	0.3	0.3	0.3

CARBURETOR AND OIL INJECTION SYSTEM CARBURATEUR ET SYSTÈME D'INJECTION D'HUILE

SYSTEM SYSTÈME	CODE	DESCRIPTION	MINI Z	TUNDRA R	GRAND TOURING 380 F	LEGEND 380 F MX Z 380 F	SKANDIC 440 F LT	SUMMIT 550 F	GRAND TOURING 550 F	LEGEND 500 F MX Z 550 F	SKANDIC 500 F WT/SWT	SKANDIC 500 F SPORT
			1	2	3	4	5	6	7	8	9	10

02	26	OIL INJECTION LINES (2) BOYAUX D'HUILE À INJECTION (2)			0.4	0.4	0.4	0.4	0.4	0.4	0.4	0.4
02	27	OIL LEVEL SENSOR CONTACTEUR DE NIVEAU D'HUILE			0.4	0.4	0.4	0.4	0.4	0.4	0.5	0.4
02	28	OIL INJECTION PUMP SUPPORT SUPPORT DE LA POMPE À INJECTION		0.3								
02	39	H.A.C. SYSTEM SYSTÈME H.A.C.						0.3				
02	40	CHOKE CABLE CÂBLE D'ÉTRANGLEUR	0.3		0.3	0.3	0.3	0.3	0.3	0.3	0.3	0.3

Carburetor Mini Z/Carburateur Mini Z

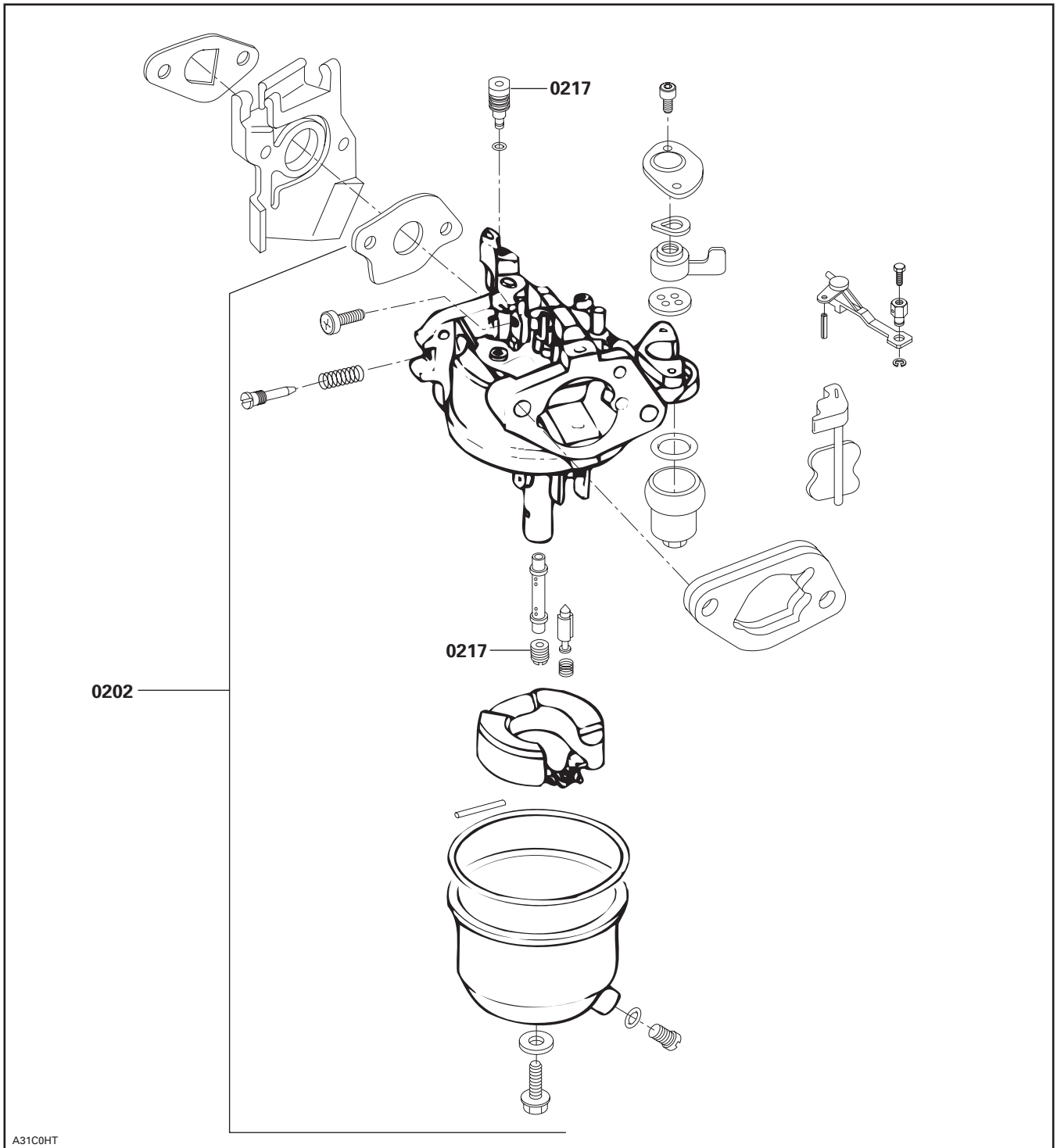

Carburetor VM Type/Carburateur type VM

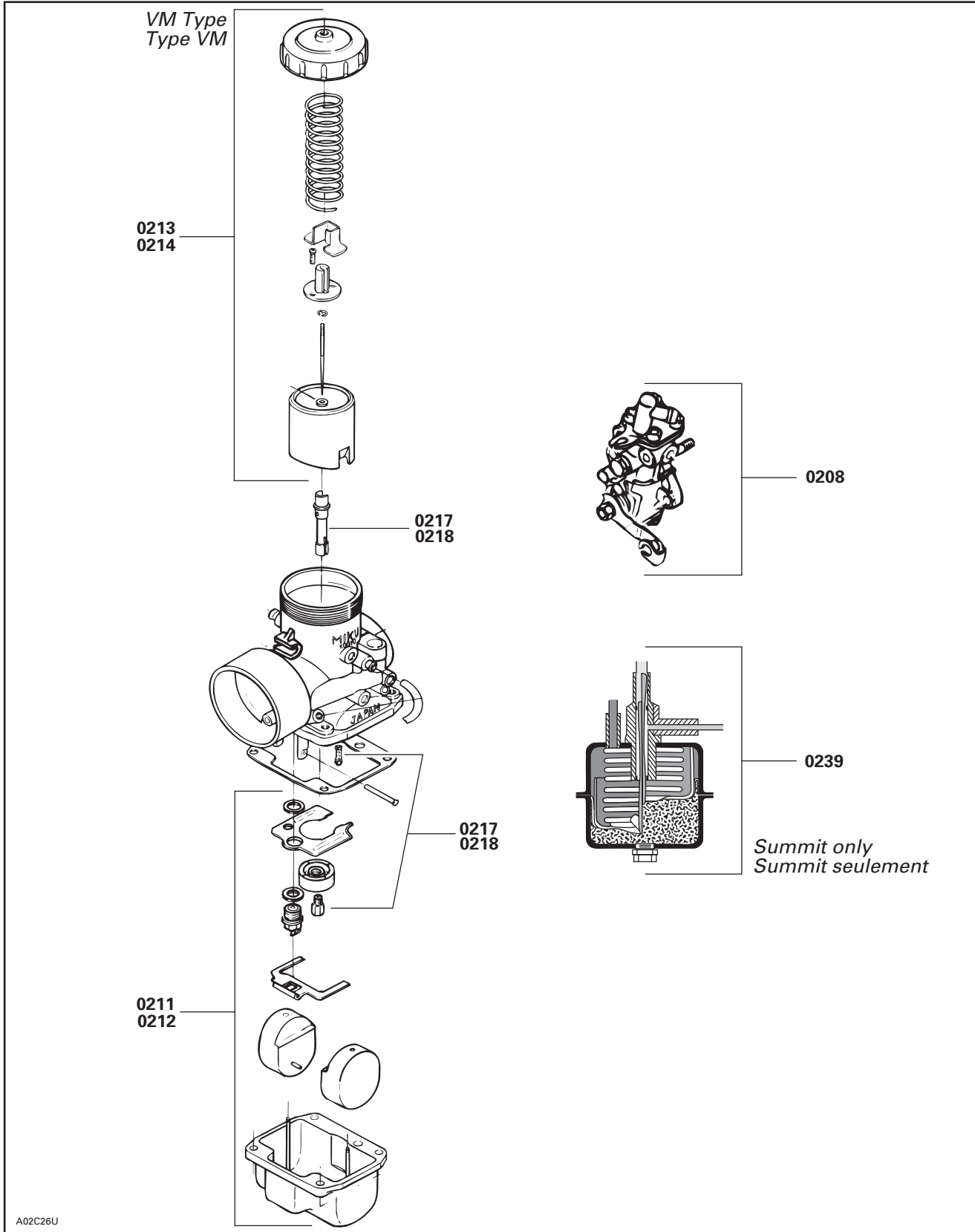

SYSTEM SYSTÈME	CODE	DESCRIPTION	MINI Z	TUNDRA R	GRAND TOURING 380 F	LEGEND 380 F MX Z 380 F	SKANDIC 440 F LT	SUMMIT 550 F	GRAND TOURING 550 F	LEGEND 500 F MX Z 550 F	SKANDIC 500 F WT/SWT	SKANDIC 500 F SPORT
			1	2	3	4	5	6	7	8	9	10

03	00	NO LABOR INVOLVED AUCUNE MAIN-D'OEUVRE IMPLIQUÉE	0	0	0	0	0	0	0	0	0	0
03	01	FLYWHEEL VOLANT MOTEUR		0.4	0.4	0.4	0.4	0.4	0.4	0.4	0.3	0.4
03	02	MAGNETO ASS'Y MAGNÉTO COMPLET		0.6	0.6	0.6	0.6	0.6	0.6	0.6	0.5	0.6
03	06	LIGHTING COIL BOBINE D'ÉCLAIRAGE	2.0									
03	08	IGNITION COIL BOBINE D'ALLUMAGE	1.8									
03	09	ARMATURE PLATE ALONE PLATEAU D'ARMATURE SEUL		1.3	1.4	1.4	1.4	1.4	1.4	1.4	1.4	1.4
03	10	IGNITION CABLE CÂBLE D'ALLUMAGE		0.3	0.3	0.3	0.3	0.3	0.3	0.3	0.3	0.3
**		TIMING RÉGLAGE DE L'ALLUMAGE		0.4	0.4	0.4	0.4	0.4	0.4	0.4	0.4	0.4
03	13	TRIGGER COIL (1) BOBINE DE DÉCLENCHEMENT (1)									0.9	
03	15	SPARK PLUG PROTECTOR PROTECTEUR DE BOUGIES	0.3	0.3	0.3	0.3	0.3	0.3	0.3	0.3	0.3	0.3
03	17	FLYWHEEL OR KEY VOLANT OU CLAVETTE	2.0									
03	18	FAN OR COVER VENTILATEUR OU COUVERCLE	1.8									
03	19	TRIGGER COIL (reverse) BOBINE DE DÉCLENCHEMENT (marche arrière)		0.6	0.6	0.6		0.6	0.6	0.6		0.6

4 Strokes Engine Mini Z/Moteur 4 temps Mini Z

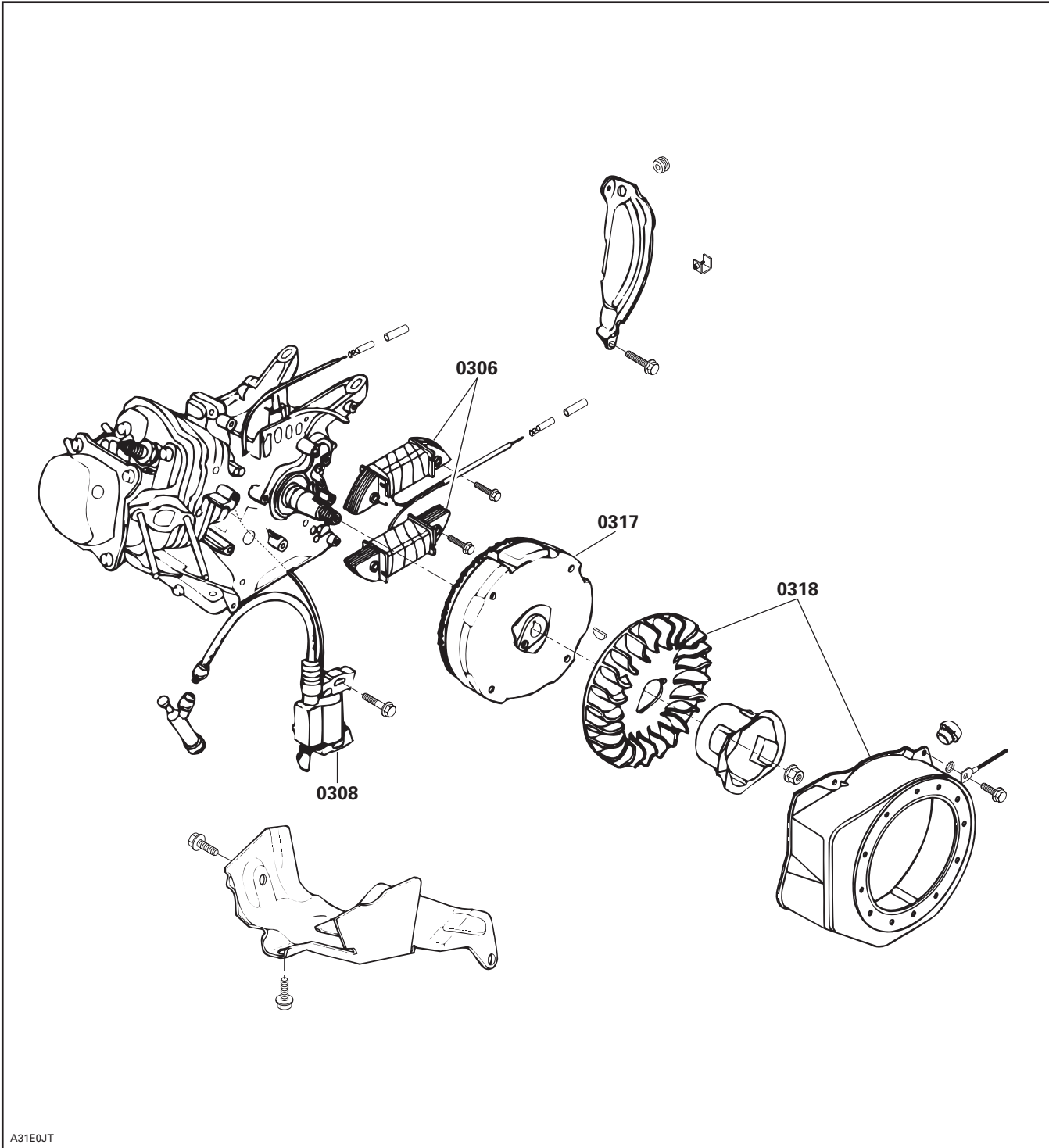

Tundra

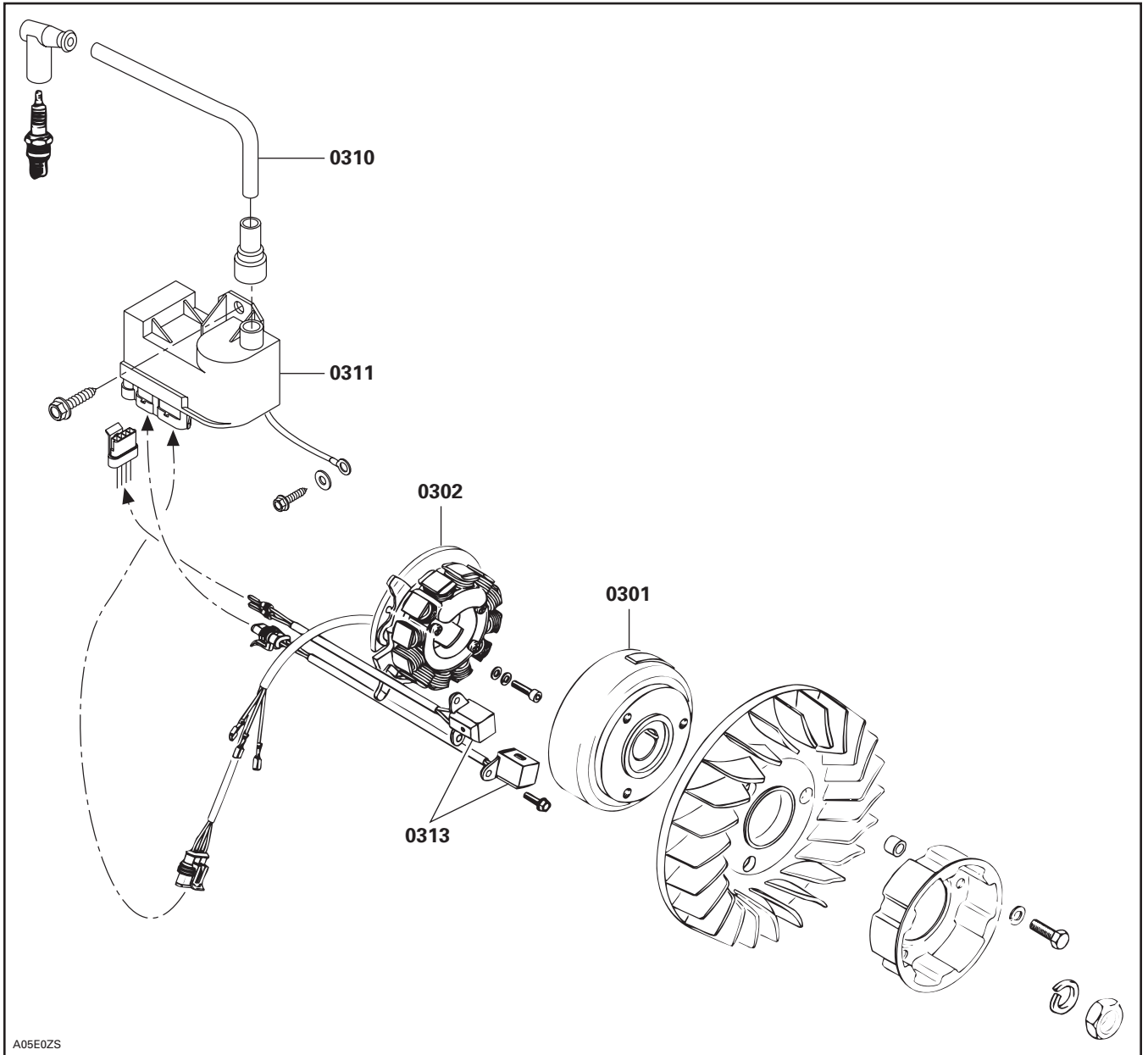

Engine Type 377-443-503/Type de moteur 377-443-503

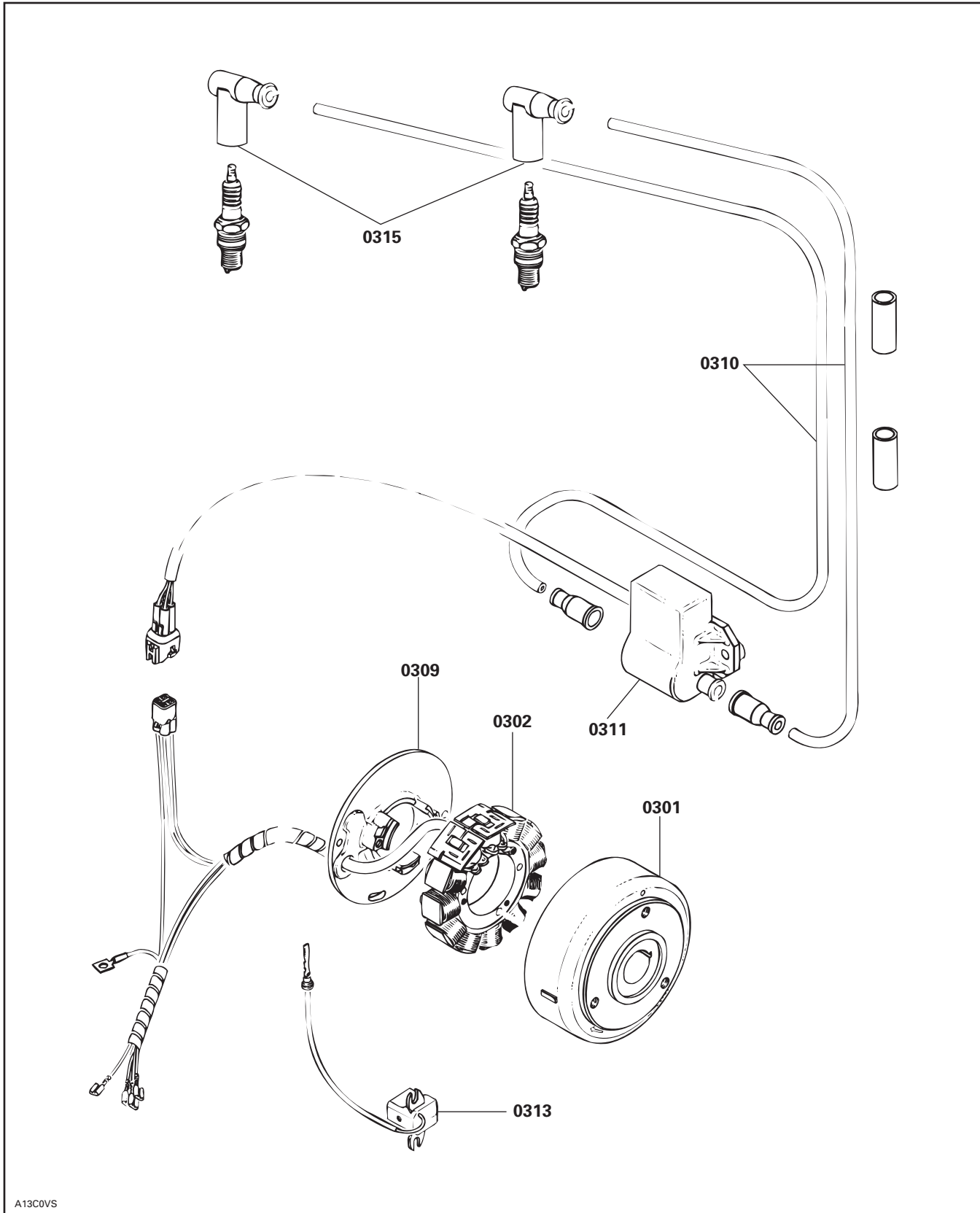

A13C0VS

SYSTEM SYSTÈME	CODE	DESCRIPTION	MINI Z	TUNDRA R	GRAND TOURING 380 F	LEGEND 380 F MX Z 380 F	SKANDIC 440 F LT	SUMMIT 550 F	GRAND TOURING 550 F	LEGEND 500 F MX Z 550 F	SKANDIC 500 F WT/SWT	SKANDIC 500 F SPORT
			1	2	3	4	5	6	7	8	9	10

04	00	NO LABOR INVOLVED AUCUNE MAIN-D'OEUVRE IMPLIQUÉE	0	0	0	0	0	0	0	0	0	0
04	01	REWIND STARTER (any/or all parts) EXCEPT HANDLE DÉMARREUR À RAPPEL (toutes pièces) SAUF POIGNÉE	1.8	0.7	0.5	0.5	0.5	0.5	0.5	0.5	0.4	0.5
04	02	ELECTRIC STARTER ASS'Y DÉMARREUR ÉLECTRIQUE COMPLET			0.4	0.4			0.4	0.4	0.3	0.4
04	03	SWITCH ASS'Y INTERRUPTEUR COMPLET			0.4	0.4			0.4	0.4	1.0	0.4
04	04	LEVER, CLUTCH, HOUSING, BUSHING (all parts) LEVIER, EMBRAYAGE, BOÎTIER, DOUILLE, (toutes pièces)			0.8	0.8		0.8	0.8	0.8	0.8	0.8
04	05	HOUSING, BUSHING, BRUSH, BRUSH HOLDER (all parts) BOÎTIER, DOUILLE, BALAI, PORTE-BALAI (toutes pièces)			0.8	0.8			0.8	0.8	0.8	0.8
04	06	STARTER BRACKET PLAQUE DE FIXATION DE DÉMARREUR			0.4	0.4			0.4	0.4	0.3	0.4
04	07	STARTER SUPPORT SUPPORT DE DÉMARREUR			0.5	0.5			0.5	0.5	0.6	0.5
04	08	STARTER GEAR SYSTÈME D'EMBAYAGE			0.9	0.8			0.8	0.8	0.8	0.8
04	09	REWIND STARTER HANDLE POIGNÉE DU DÉMARREUR À RAPPEL	0.3	0.3	0.3	0.3	0.3	0.3	0.3	0.3	0.3	0.3

04 STARTER DÉMARREUR

SYSTEM/SYSTEME

Starter/Démarreur

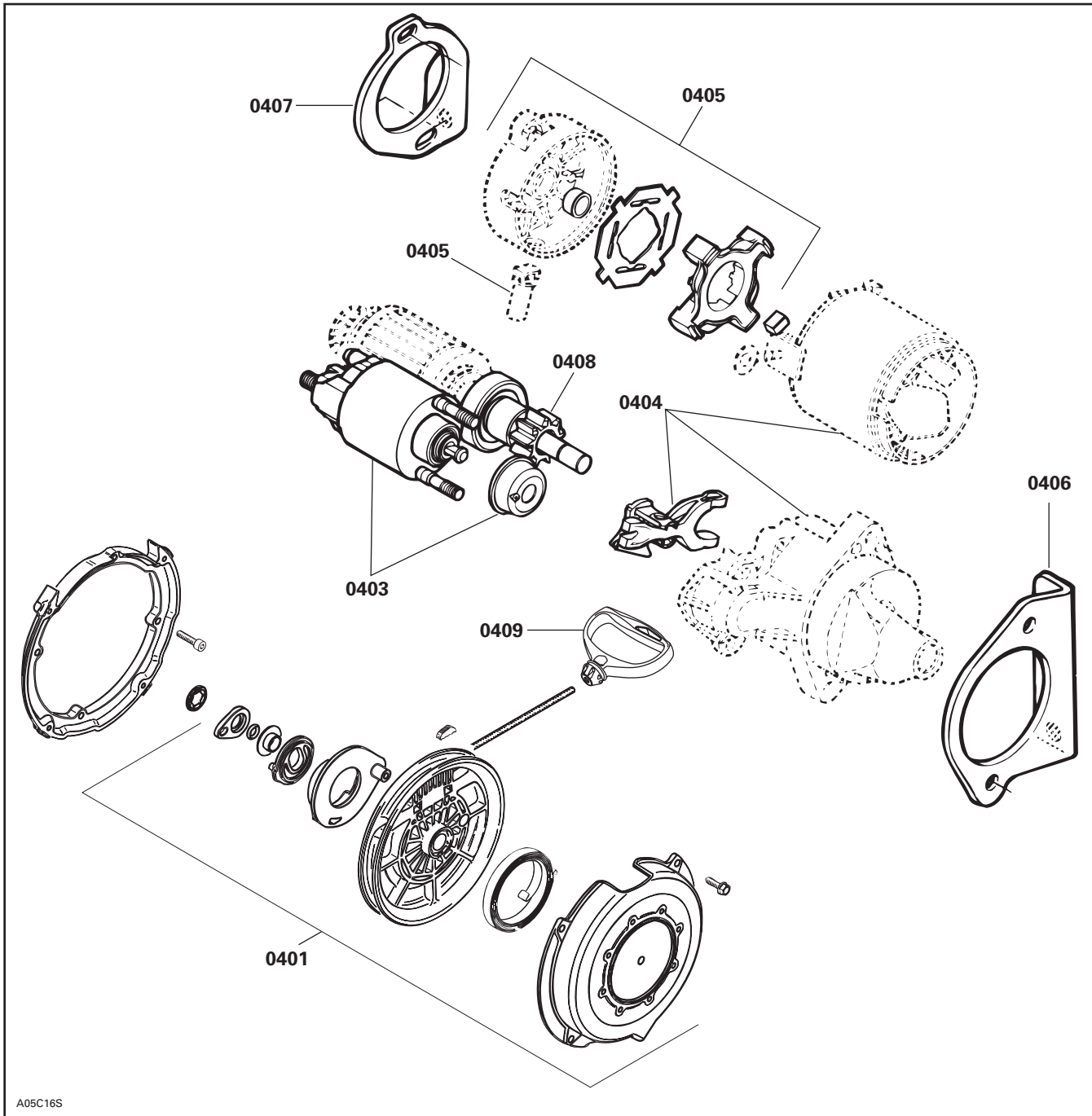

A05C16S

TRANSMISSION SYSTEM SYSTÈME DE TRANSMISSION

05

SYSTEM/SYSTEME

SYSTEM SYSTÈME	CODE	DESCRIPTION	MINI Z	TUNDRA R	GRAND TOURING 380 F	LEGEND 380 F MX Z 380 F	SKANDIC 440 F LT	SUMMIT 550 F	GRAND TOURING 550 F	LEGEND 500 F MX Z 550 F	SKANDIC 500 F WT/SWT	SKANDIC 500 F SPORT
			1	2	3	4	5	6	7	8	9	10

05	00	NO LABOR INVOLVED AUCUNE MAIN-D'ŒUVRE IMPLIQUÉE	0	0	0	0	0	0	0	0	0	0
05	01	DRIVE PULLEY ASS'Y OR SLIDING FLANGE POULIE MOTRICE OU FLASQUE COULISSANTE	0.3	0.3	0.3	0.3		0.3	0.3	0.3	0.3	0.3
05	02	DRIVE PULLEY GOVERNOR CUP AND/OR RAMPS CUVETTE DE RÉGULATEUR POULIE ET/OU RAMPES		0.3	0.3	0.3						
05	03	DRIVE PULLEY OUTER HALF AND/OR SEAT AND/OR SPRING DEMI-POULIE COULISSANTE ET/OU SIÈGE ET/OU RESSORT		0.4	0.3	0.3						
05	04	HUB PLUG AND/OR BUSHING AND/OR COUNTERWEIGHT CHAPEAU DE MOYEU ET/OU DOUILLE ET/OU CONTREPOID		0.3	0.5	0.5						
05	06	TRA GOVERNOR CUP AND/OR FIXED HALF CUVETTE DE RÉGULATEUR ET/OU PARTIE FIXE TRA						0.3	0.3	0.3	0.3	0.3
05	07	TRA RAMPS AND/OR ADJUSTMENT SCREW RAMPES ET/OU VIS DE RÉGLAGE DE POULIE TRA						0.3	0.3	0.3	0.3	0.3
05	08	TRA SPRING COVER AND/OR SPRING AND/OR BUSHING COUVERCLE ET/OU RESSORT ET/OU DOUILLE POULIE TRA						0.7	0.7	0.7	0.7	0.7
05	09	TRA SLIDER SHOES AND/OR SPRINGS GLISSIÈRE ET/OU RESSORT DE POULIE TRA						0.3	0.3	0.3	0.3	0.3
05	10	TRA SLIDING HALF, BUSHING AND/OR LEVER ASS'Y DEMI-POULIE COULISSANTE, DOUILLE ET/OU LEVIER COMPLET TRA						0.5	0.5	0.5	0.5	0.5
05	11	DRIVEN PULLEY FIXED HALF DEMI-POULIE MENÉE FIXE		1.2	0.3	0.3	0.3	0.3	0.3	0.3	0.3	0.3
05	12	DRIVEN PULLEY SLIDING HALF DEMI-POULIE MENÉE COULISSANTE		1.2	0.3	0.3	0.3	0.3	0.3	0.3	0.3	0.3
05	13	DRIVEN PULLEY CAM AND/OR SPRING CAME ET/OU RESSORT DE POULIE MENÉE		1.2	0.3	0.3	0.3	0.3	0.3	0.3	0.3	0.3
05	14	DRIVEN PULLEY SMALL BUSHING PETITE DOUILLE DE POULIE MENÉE		1.2	0.6	0.6	0.6	0.6	0.6	0.6	0.5	0.6
05	15	DRIVEN PULLEY LARGE BUSHING GROSSE DOUILLE DE POULIE MENÉE		1.2	0.6	0.6	0.6	0.6	0.6	0.6	0.4	0.6
05	16	DRIVEN PULLEY SUPPORT SUPPORT DE POULIE MENÉE		0.3								
05	17	COUNTERSHAFT BALL BEARING AND/OR FLANGE ROULEMENT BILLE DE L'ARBRE DE RENVOI ET/OU FLASQUE			0.4	0.4	0.4	0.4	0.4	0.4		0.4
05	18	COUNTERSHAFT ARBRE DE RENVOI			2.0	2.0	2.0	2.0	2.0	2.0		2.0
05	19	DRIVE BELT AND/OR BELT GUARD COURROIE D'ENTRAÎNEMENT ET/OU GARDE-COURROIE		0.3	0.3	0.3	0.3	0.3	0.3	0.3	0.3	0.3

SYSTEM SYSTÈME	CODE	DESCRIPTION	MINI Z	TUNDRA R	GRAND TOURING 380 F	LEGEND 380 F MX Z 380 F	SKANDIC 440 FLT	SUMMIT 550 F	GRAND TOURING 550 F	LEGEND 500 F MX Z 550 F	SKANDIC 500 F WT/SWT	SKANDIC 500 F SPORT
			1	2	3	4	5	6	7	8	9	10

05	20	CHAINCASE SEAL AND/OR BEARING ANNEAU D'ÉTANCHÉITÉ DE CARTER ET/OU ROULEMENT		1.6	1.4	1.4	1.2	1.2	1.4	1.4		1.4
05	21	CHAINCASE CARTER DE CHAÎNE		1.6	2.0	2.0	1.8	1.8	2.0	2.0	1.4	2.0
05	22	CHAINCASE COVER COUVERCLE DE CARTER DE CHAÎNE		0.3	0.3	0.3	0.3	0.5	0.5	0.5	0.3	0.5
05	23	CHAINCASE UPPER AND/OR CENTRAL SPROCKET PIGNON SUPÉRIEUR DE CARTER ET/OU PIGNON CENTRAL		0.3	0.6	0.5	0.5	0.5	0.6	0.6	3.8	0.6
05	24	CHAINCASE LOWER SPROCKET PIGNON INFÉRIEUR DE CARTER DE CHAÎNE		0.5	0.6	0.6	0.4	0.5	0.6	0.6	4.3	0.6
05	25	CHAINCASE DRIVE CHAIN CHAÎNE D'ENTRAÎNEMENT DE CARTER DE CHAÎNE		0.5	0.6	0.6	0.4	0.5	0.6	0.6		0.6
05	26	CHAINCASE TENSIONERS TENDEURS DE CARTER DE CHAÎNE		0.3	0.4	0.4	0.3	0.4	0.4	0.4		0.4
05	27	TENSIONER ADJUSTMENT SCREW VIS DE RÉGLAGE DE TENDEUR			2.0	2.0	1.8	1.8	2.0	2.0		2.0
05	30	CHAIN CHAÎNE	0.3									
05	31	CHAIN TENSIONER TENDEUR DE CHAÎNE	0.3									
05	32	LAY SHAFT GEAR ASS'Y (Rotax transmission) PIGNON D'ARBRE INTERMÉDIAIRE (transmission Rotax)	0.3								3.0	
05	34	SLIDING SLEEVE, FORK AND/OR FORK SHAFT CRABOT ET/OU FOURCHETTE ET/OU ARBRE DE FOURCHETTE									1.0	
05	39	SHIFT LEVER AND/OR SHIFT ROD LEVIER DE TRANSMISSION ET/OU TIGE									0.3	
05	44	RING GEAR COURONNE DE DÉMARRAGE			0.5	0.5			0.5	0.5	0.4	0.5
05	45	REVERSE GEARWHEEL AND SHAFT ENGRENAGE ET ARBRE DE MARCHE ARRIÈRE									2.5	
05	46	SIDE COVER COUVERCLE DE CÔTÉ									0.5	
05	47	COVER, LOWER SIDE COUVERCLE CÔTÉ INFÉRIEUR									0.4	
05	48	CENTER SHAFT AXE CENTRAL									3.5	
05	49	DRIVE PULLEY GUARD GARDE DE POULIE MOTRICE	0.3									
05	50	SPROCKET 48 TEETH ENGRENAGE 48 DENTS	0.3									
05	69	DRIVE PULLEY ASS'Y POULIE MOTRICE COMPLÈTE					0.3					

TRANSMISSION SYSTEM SYSTÈME DE TRANSMISSION

05

SYSTEM/SYSTEME

SYSTEM SYSTÈME	CODE	DESCRIPTION	MINI Z	TUNDRA R	GRAND TOURING 380 F	LEGEND 380 F MX Z 380 F	SKANDIC 440 FLT	SUMMIT 550 F	GRAND TOURING 550 F	LEGEND 500 F MX Z 550 F	SKANDIC 500 F WT/SWT	SKANDIC 500 F SPORT
			1	2	3	4	5	6	7	8	9	10
05	70	COVER AND/OR SPRING COUVERCLE ET/OU RESSORT					0.4					
05	71	SPIDER AND/OR THRUST BUTTONS AND/OR ROLLERS AND/OR FIXED HALF L'ARAIGNÉE ET/OU BOUTON DE GUIDAGE ET/OU ROULEAU ET/OU FLASQUE FIXE					0.6					
05	72	SLIDING HALF AND/OR CAM ARM FLASQUE COULISSANTE ET/OU RAMPE					0.6					

Clutch Mini Z/Embrayage Mini Z

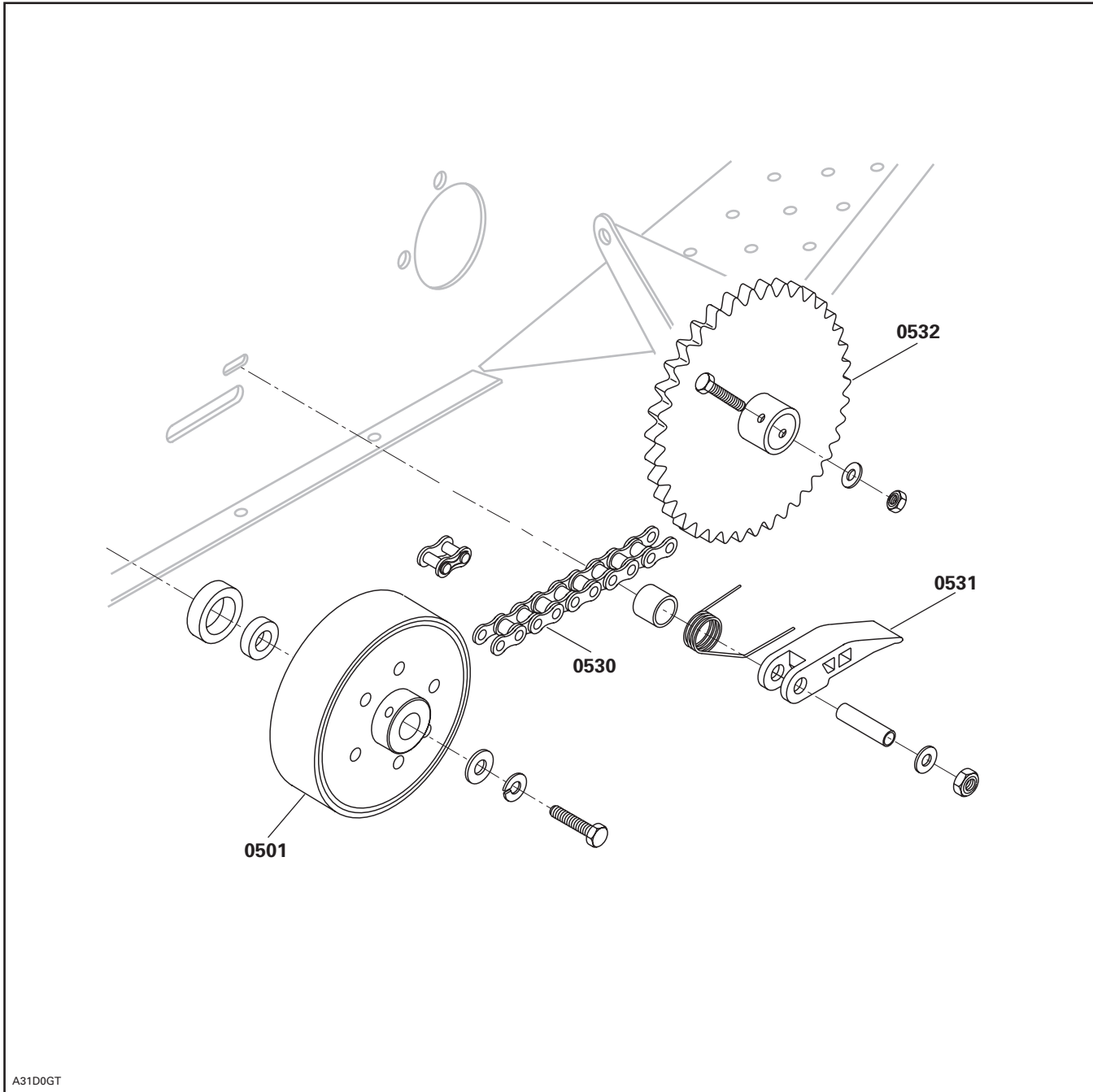

TRA Drive Pulley/Poulie motrice TRA

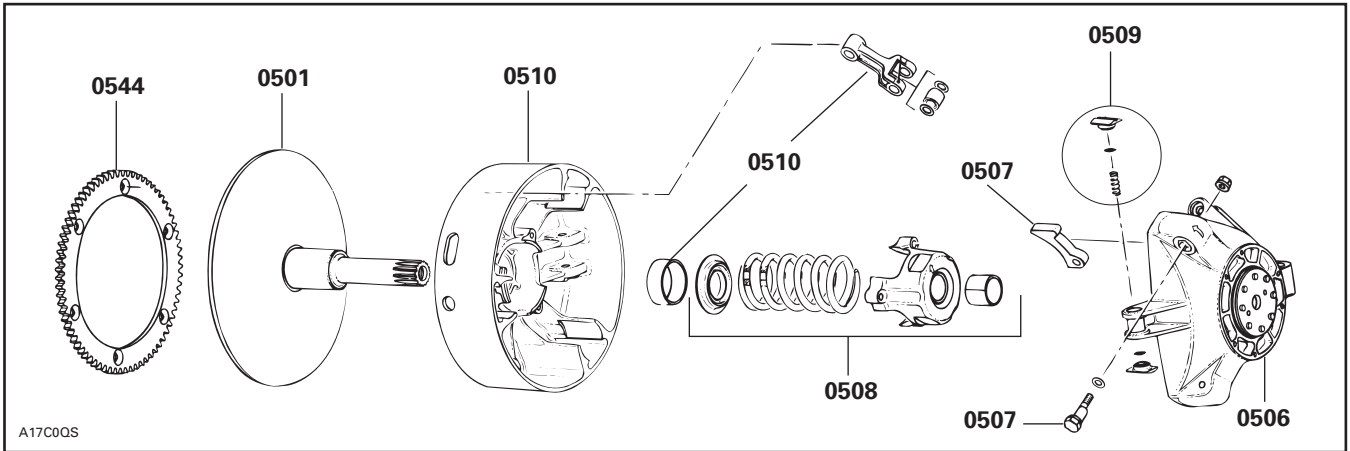

Driven Pulley on S-Series/Poulie menée série S

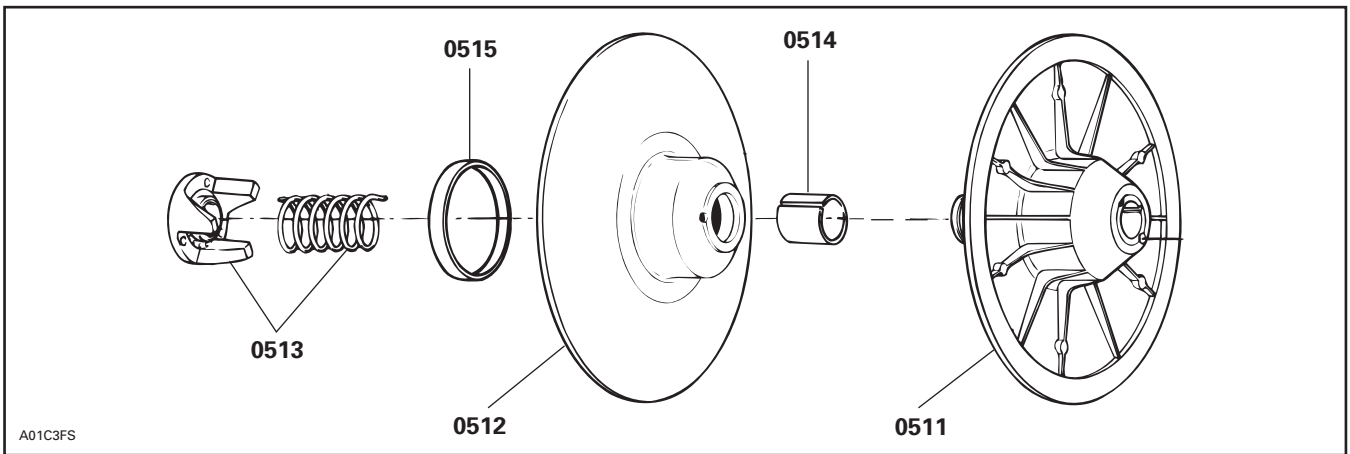

Driven Pulley on Skandic WT/SWT/WT LC/Poulie menée Skandic WT/SWT/WT LC

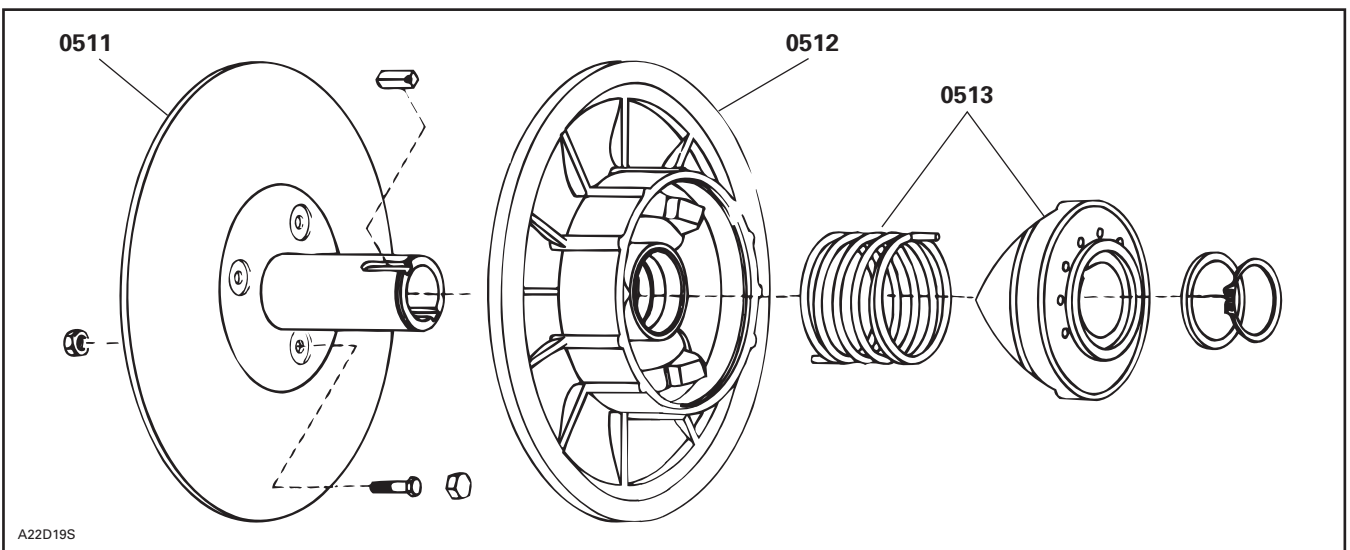

Comet 102 C

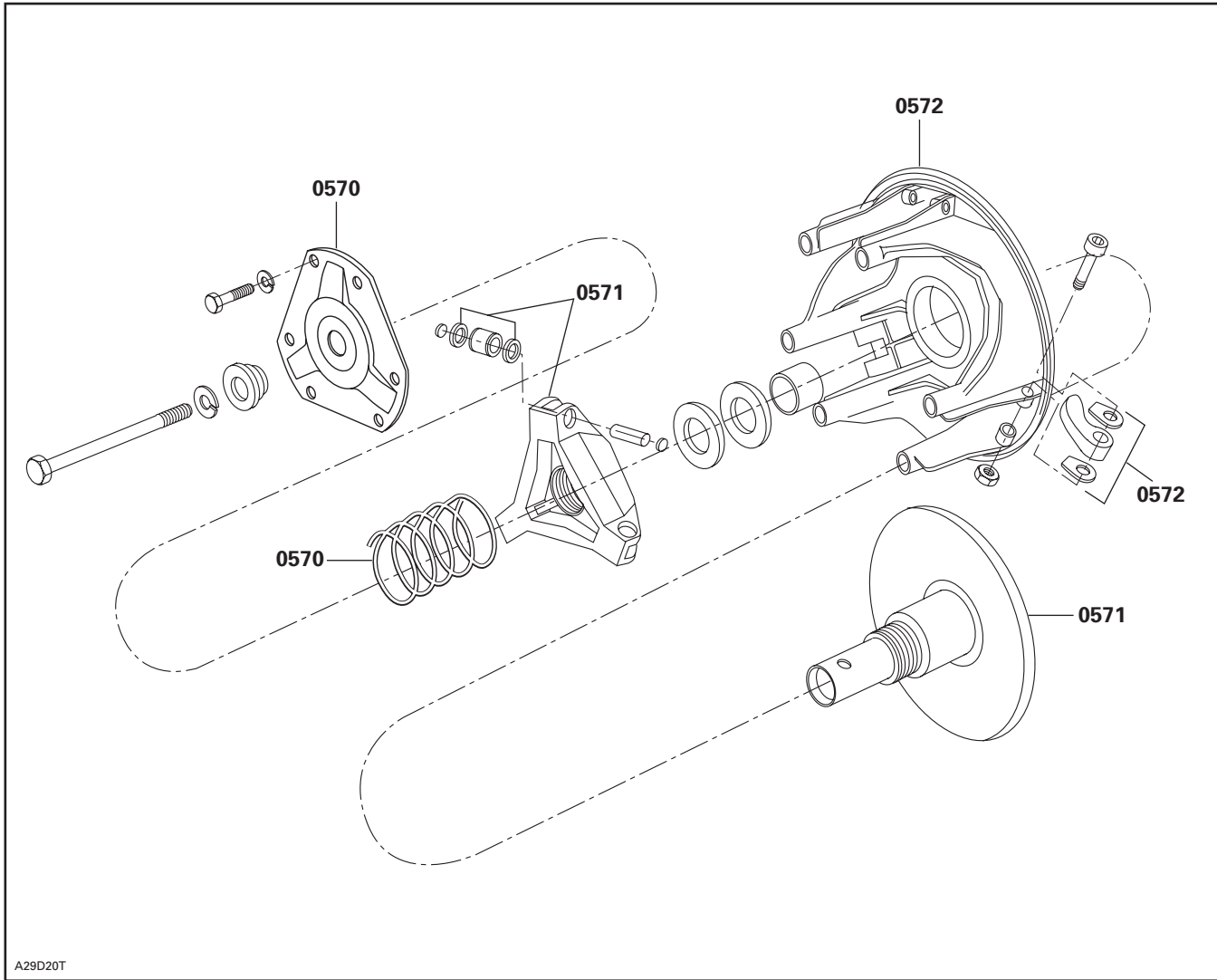

A29D20T

Tundra

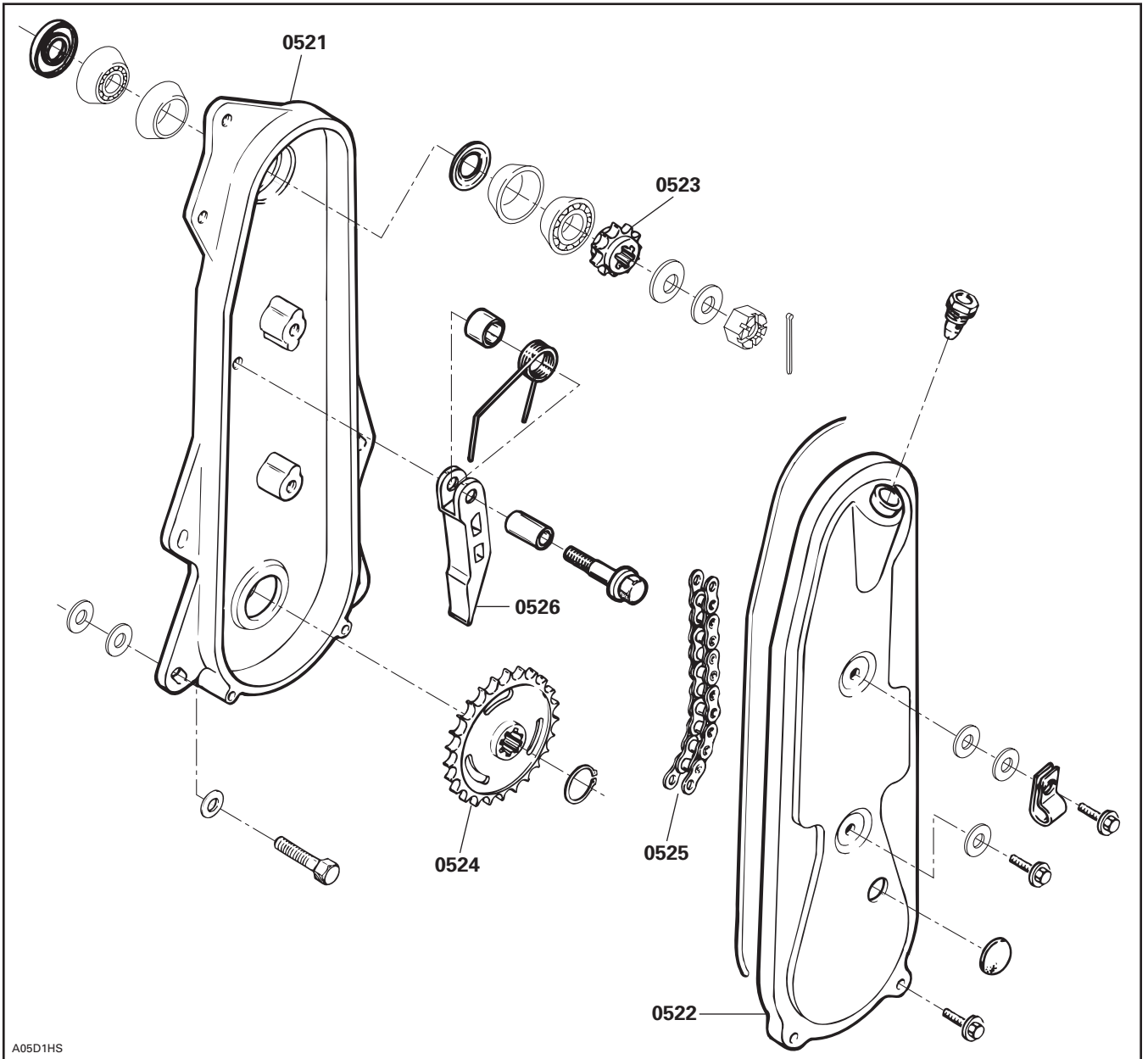

Chaincase/Carter de chaîne

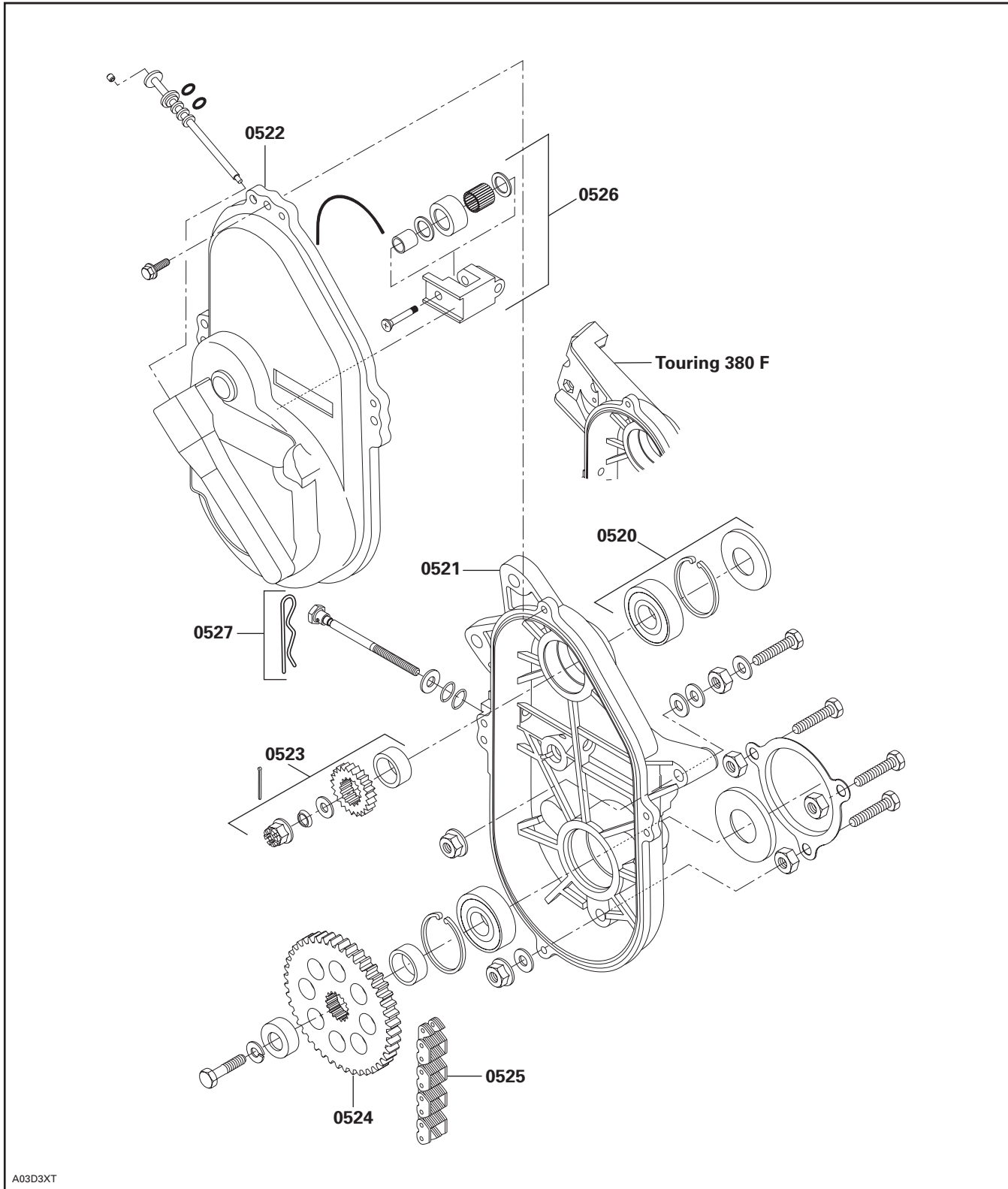

3 Speed Gear Box on Skandic WT/SWT/Boîte de vitesse à 3 rapports Skandic WT/SWT

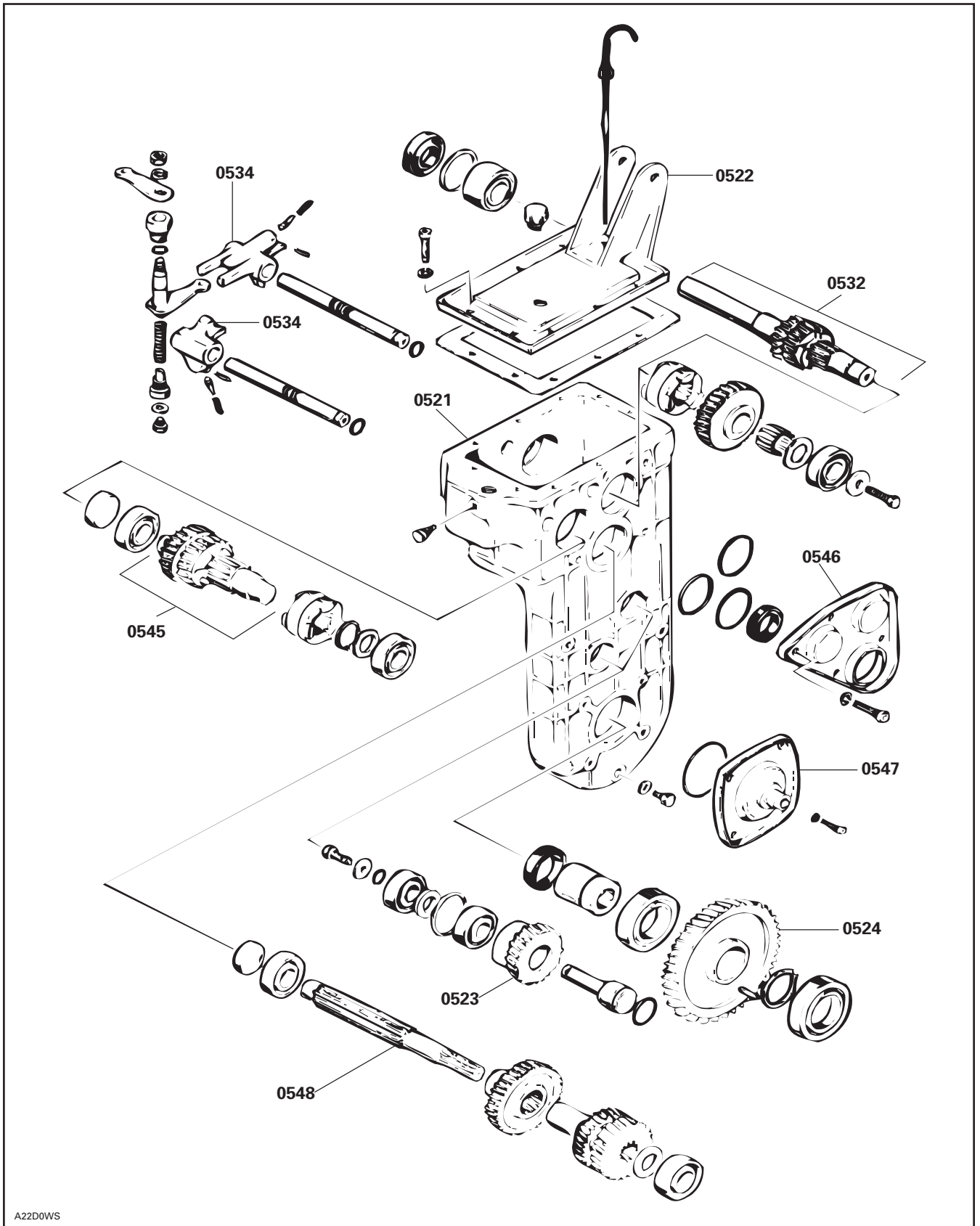

A22D0WS

SYSTEM SYSTÈME	CODE	DESCRIPTION	MINI Z	TUNDRA R	GRAND TOURING 380 F	LEGEND 380 F MX Z 380 F	SKANDIC 440 F LT	SUMMIT 550 F	GRAND TOURING 550 F	LEGEND 500 F MX Z 550 F	SKANDIC 500 F WT/SWT	SKANDIC 500 F SPORT
			1	2	3	4	5	6	7	8	9	10

06	00	NO LABOR INVOLVED AUCUNE MAIN-D'OEUVRE IMPLIQUÉE	0	0	0	0	0	0	0	0	0	0
06	01	BRAKE CABLE, LINE AND HOUSING CÂBLE, CONDUITE DE FREIN ET GAINÉ	0.3	0.3	0.6	0.7	0.6	0.7	0.7	0.7	0.7	0.7
06	02	BRACKET, CALIPER, BRAKE PAD, RELEASE SPRING SUPPORT, ÉTRIER, PLAQUETTE, CLIQUET, LEVIER		0.3	0.5	0.5	0.5	0.8	0.8	0.8	0.8	0.8
06	03	DISC DISQUE		1.2	1.2	1.2	1.2	1.2	1.2	1.2	1.2	1.2
06	04	SHOE, LEVER, SPRING SABOT DE FREIN, LEVIER, RESSORT	0.3									
06	05	BRAKE PADS PLAQUETTES DE FREIN			0.4	0.4	0.4	0.3	0.3	0.3	0.3	0.3
06	06	MASTER CYLINDER MAÎTRE CYLINDRE						1.2	1.2	1.2	1.2	1.2

Brake System Mini Z/Système de frein Mini Z

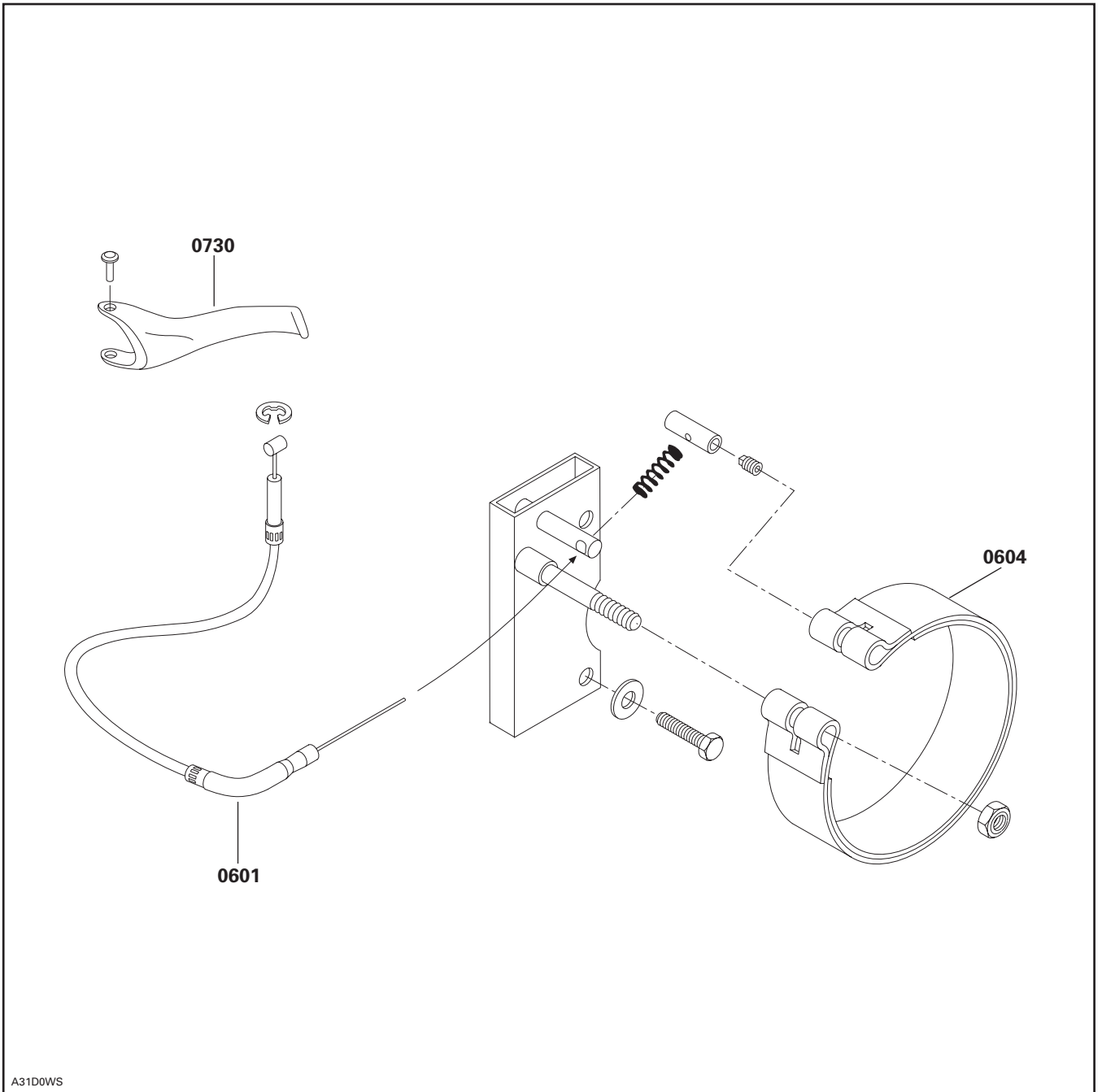

A31D0WS

Hydraulic Disc Brake/Frein à disque hydraulique

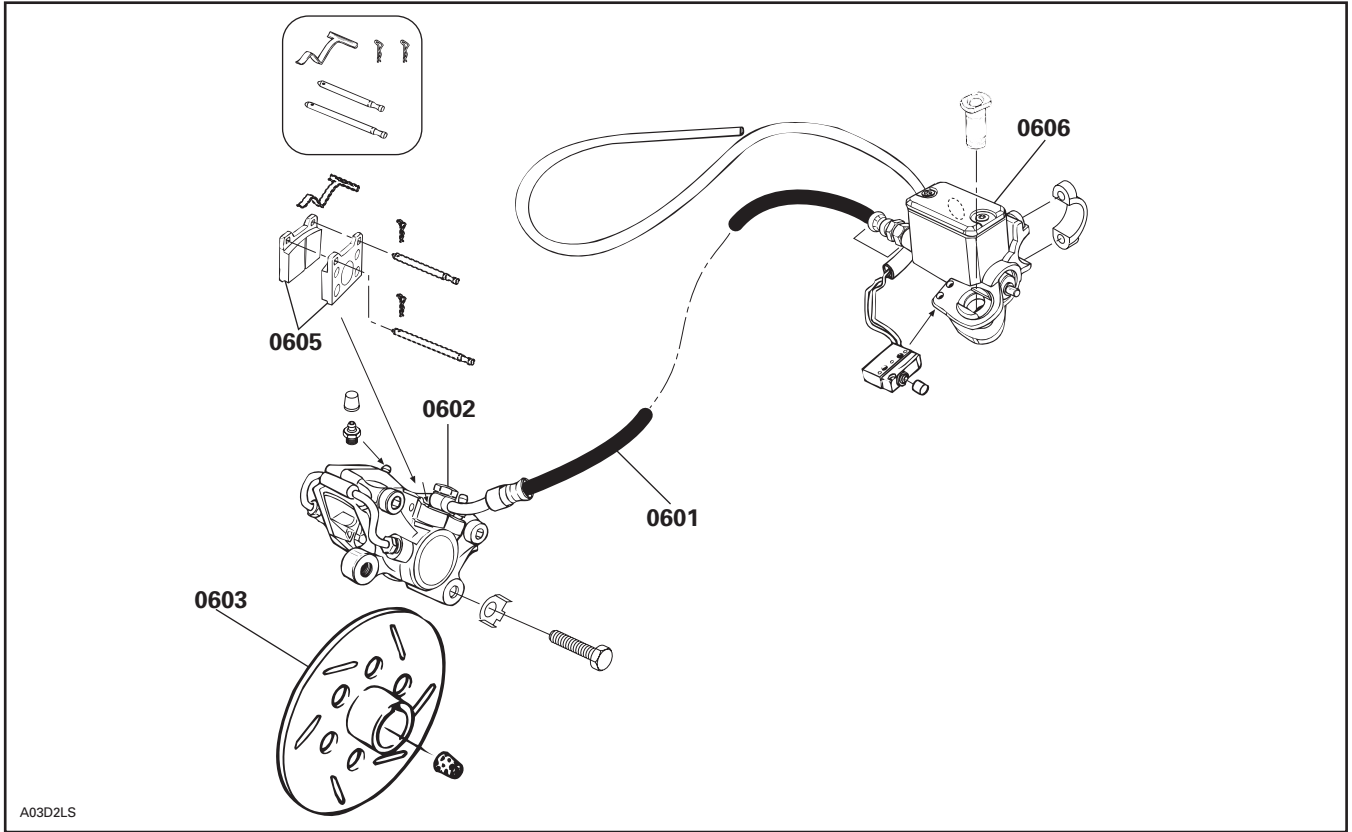

STEERING SYSTEM AND FRONT SUSPENSION SYSTÈME DE DIRECTION ET SUSPENSION AVANT

SYSTEM SYSTÈME	CODE	DESCRIPTION	MINI Z	TUNDRA R	GRAND TOURING 380 F	LEGEND 380 F MX Z 380 F	SKANDIC 440 F LT	SUMMIT 550 F	GRAND TOURING 550 F	LEGEND 500 F MX Z 550 F	SKANDIC 500 F WT/SWT	SKANDIC 500 F SPORT
			1	2	3	4	5	6	7	8	9	10

07	00	NO LABOR INVOLVED AUCUNE MAIN-D'OEUVRE IMPLIQUÉE	0	0	0	0	0	0	0	0	0	0
07	01	SKI (1) SKI (1)	0.3	0.3	0.3	0.3	0.3	0.3	0.3	0.3	0.3	0.3
07	02	SKIS (2) SKIS (2)	0.3	0.4	0.4	0.4	0.4	0.4	0.4	0.4	0.4	0.4
07	03	SKI RUNNER SHOES LISSES	0.3	0.3	0.3	0.3	0.3	0.3	0.3	0.3	0.3	0.3
07	08	SKI LEG (RH) AND/OR BUSHING JAMBE DE SKI (D) ET/OU DOUILLE	0.3	0.4	0.3	0.3	0.5	0.3	0.3	0.3	0.5	0.3
07	09	SKI LEG (LH) AND/OR BUSHING JAMBE DE SKI (G) ET/OU DOUILLE	0.3	0.3	0.3	0.3	0.4	0.3	0.3	0.3	0.4	0.3
07	10	STEERING ARM (RH) BRAS DE DIRECTION (D)		0.4	0.3	0.3	0.5	0.3	0.3	0.3	0.5	0.3
07	11	STEERING ARM (LH) BRAS DE DIRECTION (G)		0.3	0.3	0.3	0.4	0.3	0.3	0.3	0.4	0.3
07	12	RH STEERING ARM BALL JOINT JOINT À ROTULE DE BRAS DE DIRECTION (D)	0.3	0.3	0.3	0.3	0.8	0.3	0.3	0.3	0.8	0.3
07	13	LH STEERING ARM BALL JOINT JOINT À ROTULE DE BRAS DE DIRECTION (G)	0.3	0.3	0.3	0.3	0.3	0.3	0.3	0.3	0.3	0.3
07	14	TELESCOPIC TUBE, SPRING, BUSHING TUBE TÉLESCOPIQUE, RESSORT, DOUILLES		0.3			0.3				0.3	
07	15	SQUARE SHAFT, SHOCK AND/OR BUSHING ARBRE CARRÉ ET/OU AMORTISSEUR ET/OU DOUILLE		0.3			0.4				0.4	
07	17	TOP CAP CAPUCHON SUPÉRIEUR		0.3								
07	18	TIE ROD (main tube/steering arm) BARRE D'ACCOUPLMENT (colonne/bras direction)	0.3	0.3	0.6	0.6		0.6	0.6	0.6		0.6
07	19	TIE ROD (for RH and LH steering arm) BARRE D'ACCOUPLMENT (colonne/bras direction) (D ou G)	0.3	0.3	0.3	0.3		0.3	0.3	0.3		0.3
07	20	TIE ROD COVER (1) CAPUCHON DE TIMONERIE (1)			0.4	0.4		0.4	0.4	0.4		0.4
07	21	TIE ROD COVERS (2) CAPUCHONS DE TIMONERIE (2)			0.8	0.8		0.8	0.8	0.8		0.8
07	22	STEERING PIVOT ARM BRAS DE DIRECTION PIVOTANT			0.4	0.4		0.4	0.4	0.4		0.4
07	23	STEERING MAIN TUBE BALL JOINT JOINT À ROTULE DE COLONNE DE DIRECTION	0.3	0.5	0.7	0.7	0.5	0.7	0.7	0.7	0.5	0.7
07	24	STEERING MAIN TUBE COLONNE DE DIRECTION	0.6	0.9	1.7	1.7	2.0	1.7	1.7	1.7	2.0	1.7
07	25	HANDLE BAR GUIDON	0.6	0.4	0.4	0.4	0.6	0.4	0.6	0.4	0.6	0.6

STEERING SYSTEM AND FRONT SUSPENSION SYSTÈME DE DIRECTION ET SUSPENSION AVANT

07

SYSTEM/SYSTÈME

SYSTEM SYSTÈME	CODE	DESCRIPTION	MINI Z	TUNDRA R	GRAND TOURING 380 F	LEGEND 380 F MX Z 380 F	SKANDIC 440 F LT	SUMMIT 550 F	GRAND TOURING 550 F	LEGEND 500 F MX Z 550 F	SKANDIC 500 F WT/SWT	SKANDIC 500 F SPORT
			1	2	3	4	5	6	7	8	9	10

07	26	HANDLE BAR GRIP/HOUSING/PARK BRAKE POIGNÉE DE GUIDON/LOGEMENT/FREIN STATIONNEMENT	0.3	0.3	0.3	0.3	0.3	0.3	0.3	0.3	0.3	0.3
07	27	HANDLE BAR PADDING COUSSINET DE GUIDON	0.3	0.3	0.3	0.3	0.3	0.3	0.3	0.3	0.3	0.3
07	28	UPPER STEERING MAIN TUBE BUSHING DOUILLE SUPÉRIEURE DE COLONNE DE DIRECTION	0.3	0.3	0.5	0.5	0.3	0.5	0.5	0.5	0.3	0.3
07	29	LOWER STEERING MAIN TUBE BUSHING DOUILLE INFÉRIEURE DE COLONNE DE DIRECTION	0.3	0.3	1.1	1.1	0.3	1.1	1.1	1.1	0.3	1.1
07	30	BRAKE OR THROTTLE LEVER MANETTE D'ACCÉLÉRATEUR OU DE FREIN	0.3	0.3	0.3	0.3	0.3	0.3	0.3	0.3	0.3	0.3
07	31	SWING ARM (LH or RH) BRAS OSCILLANT (G ou D)			0.4	0.4		0.4	0.4	0.4		0.4
07	32	LOWER ARM (LH or RH) BRAS DE SUSPENSION INFÉRIEUR (G ou D)			0.5	0.5		0.5	0.5	0.5		0.5
07	33	UPPER ARM (LH or RH) BRAS DE SUSPENSION SUPÉRIEUR (G ou D)	0.3		0.3	0.3		0.3	0.3	0.3		0.3
07	34	UPPER ARM BALL JOINT (LH or RH) JOINT ROTULE DE SUPPORT SUPÉRIEUR (G ou D)			0.3	0.3		0.3	0.3	0.3		0.3
07	37	SHOCK AND/OR SPRING (1) AMORTISSEUR ET/OU RESSORT (1)	0.3		0.3	0.3	0.4	0.3	0.3	0.3	0.4	0.3
07	38	SHOCKS AND/OR SPRINGS (2) AMORTISSEURS ET/OU RESSORTS (2)	0.4		0.4	0.4	0.6	0.4	0.4	0.4	0.6	0.4
07	39	STABILIZER BAR BARRE STABILISATRICE			0.4	0.4		0.4	0.4	0.4		0.4
07	49	STABILIZER BAR BUSHING PLAQUETTE BARRE STABILISATRICE			0.3	0.3		0.3	0.3	0.3		0.3
07	51	STEERING MAIN TUBE BALL JOINT JOINT À ROTULE DE COLONNE DE DIRECTION					0.5			0.3	0.5	0.3
07	52	STEERING MAIN TUBE BALL JOINT (RH) JOINT À ROTULE DE COLONNE DE DIRECTION (D)					0.9				0.9	
07	55	FRONT SWING ARM DECAL (1 or 2) DÉCALQUE BRAS SUSPENSION AVANT (1 ou 2)			0.3	0.3		0.3	0.3	0.3		0.3
07	59	TIE ROD (main tube) BARRE D'ACCOUPLMENT (arbre de direction)					0.5				0.5	
07	60	RH TIE ROD (main tube) BARRE D'ACCOUPLMENT DROITE (arbre de direction)					0.9				0.9	
07	68	RUBBER MOUNT SUPPORT DE CAOUTCHOUC	0.3									
07	69	HANDLE POIGNÉE	0.3									

Steering System And Front Suspension/Système de direction et suspension avant

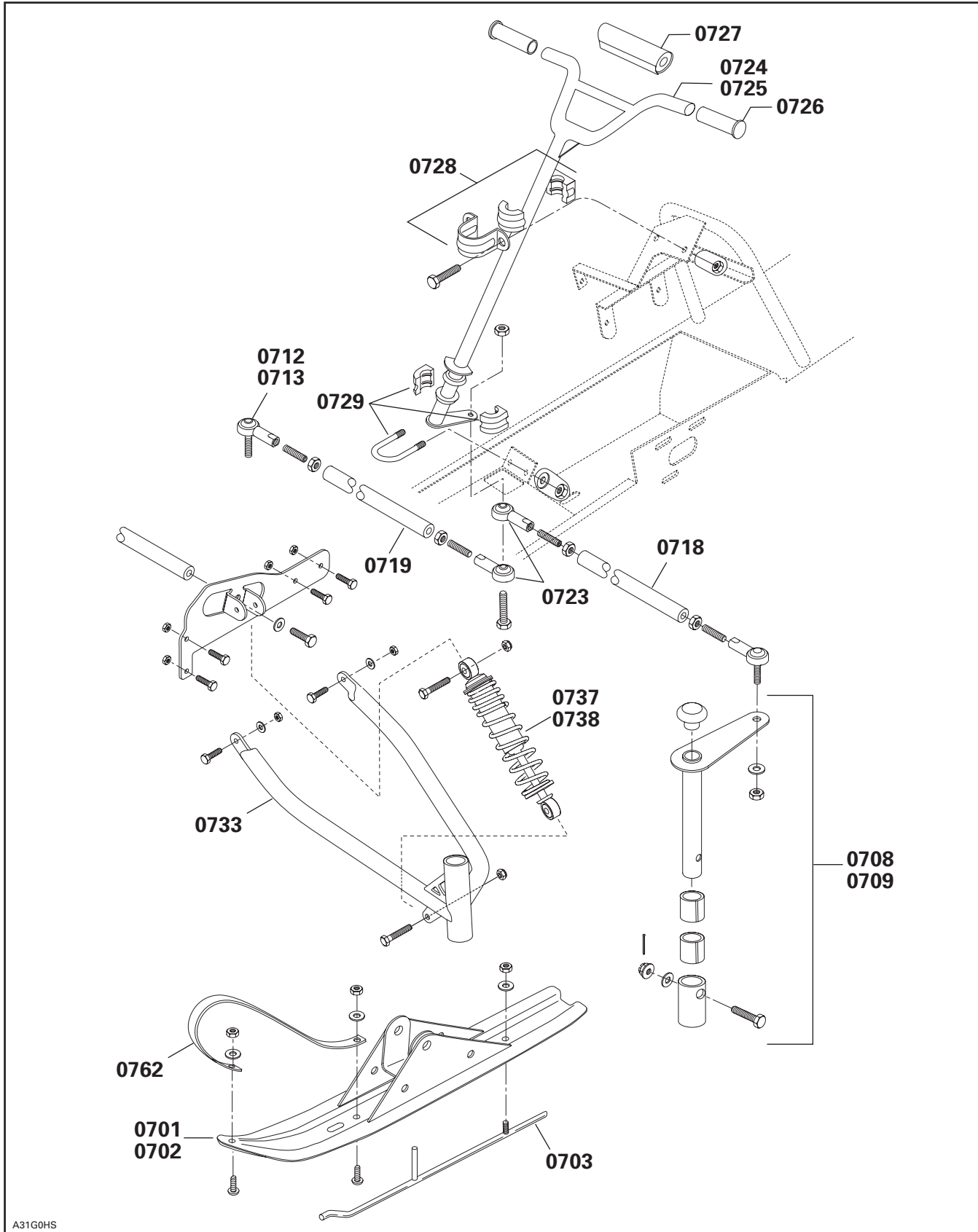

A31G0HS

STEERING SYSTEM AND FRONT SUSPENSION SYSTÈME DE DIRECTION ET SUSPENSION AVANT

07
SYSTEM/SYSTEME

Front Suspension S-Series/Suspension avant séries S

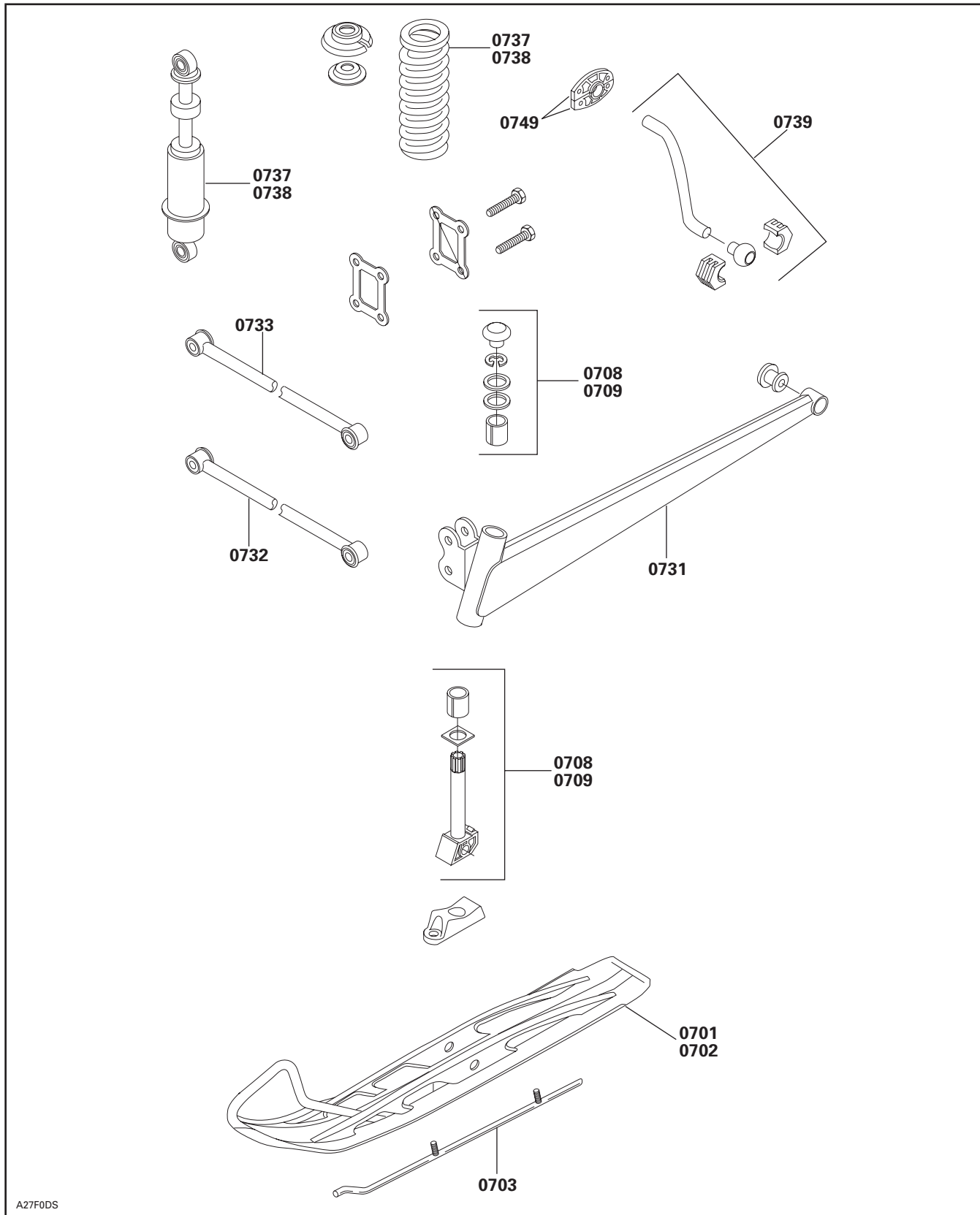

A27F0DS

Tundra

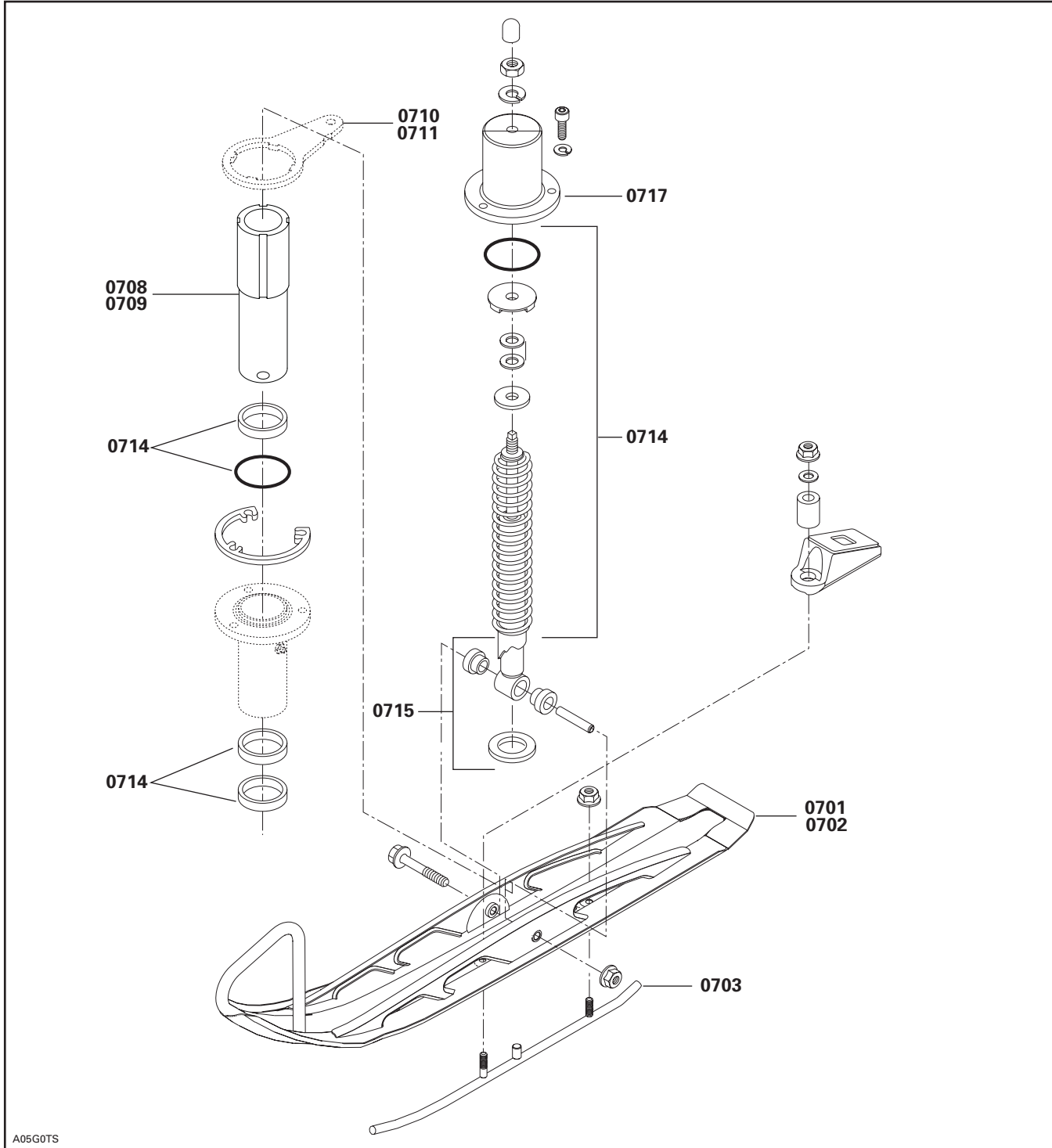

STEERING SYSTEM AND FRONT SUSPENSION SYSTÈME DE DIRECTION ET SUSPENSION AVANT

07
SYSTEM/SYSTEME

Tundra

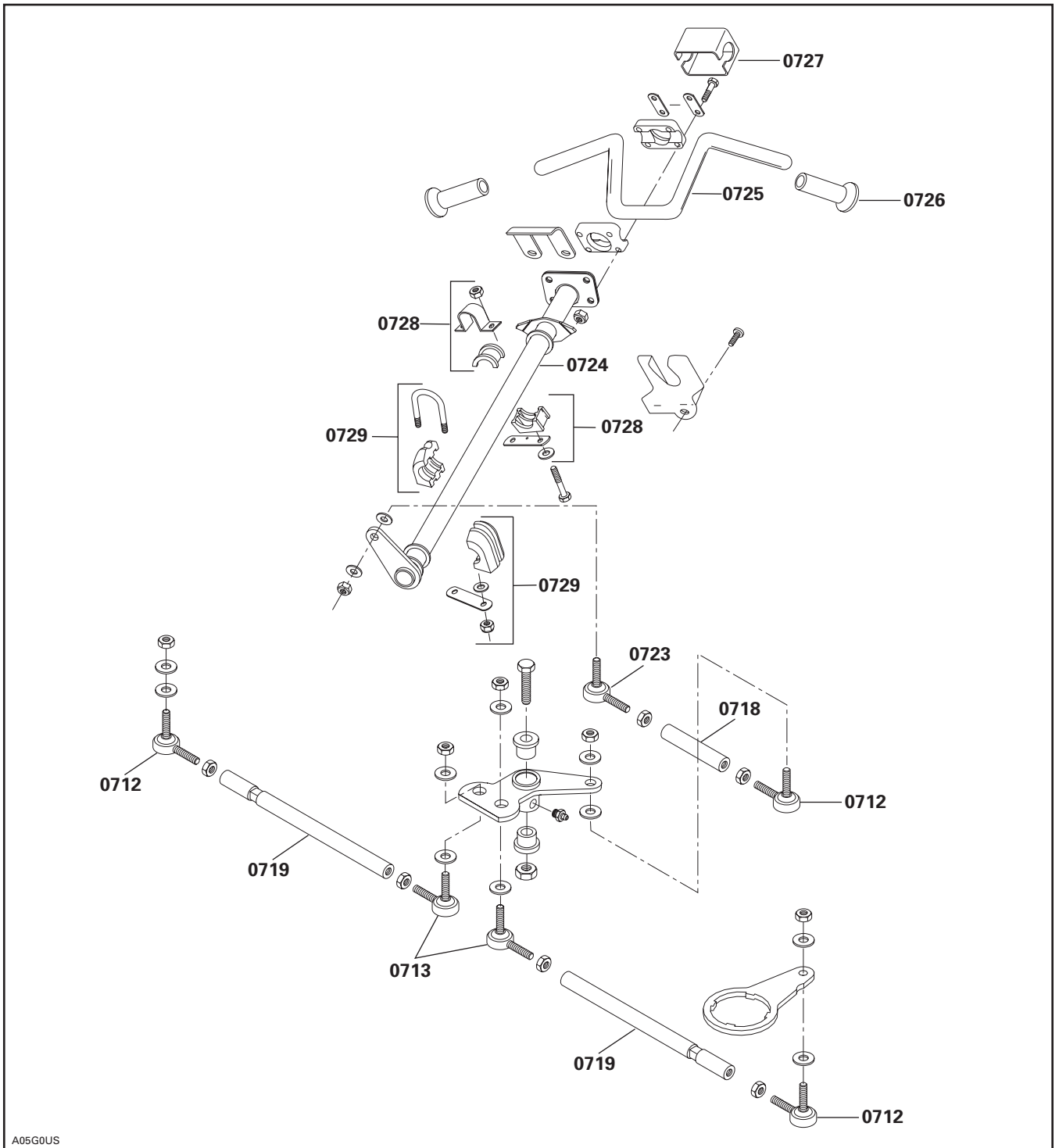

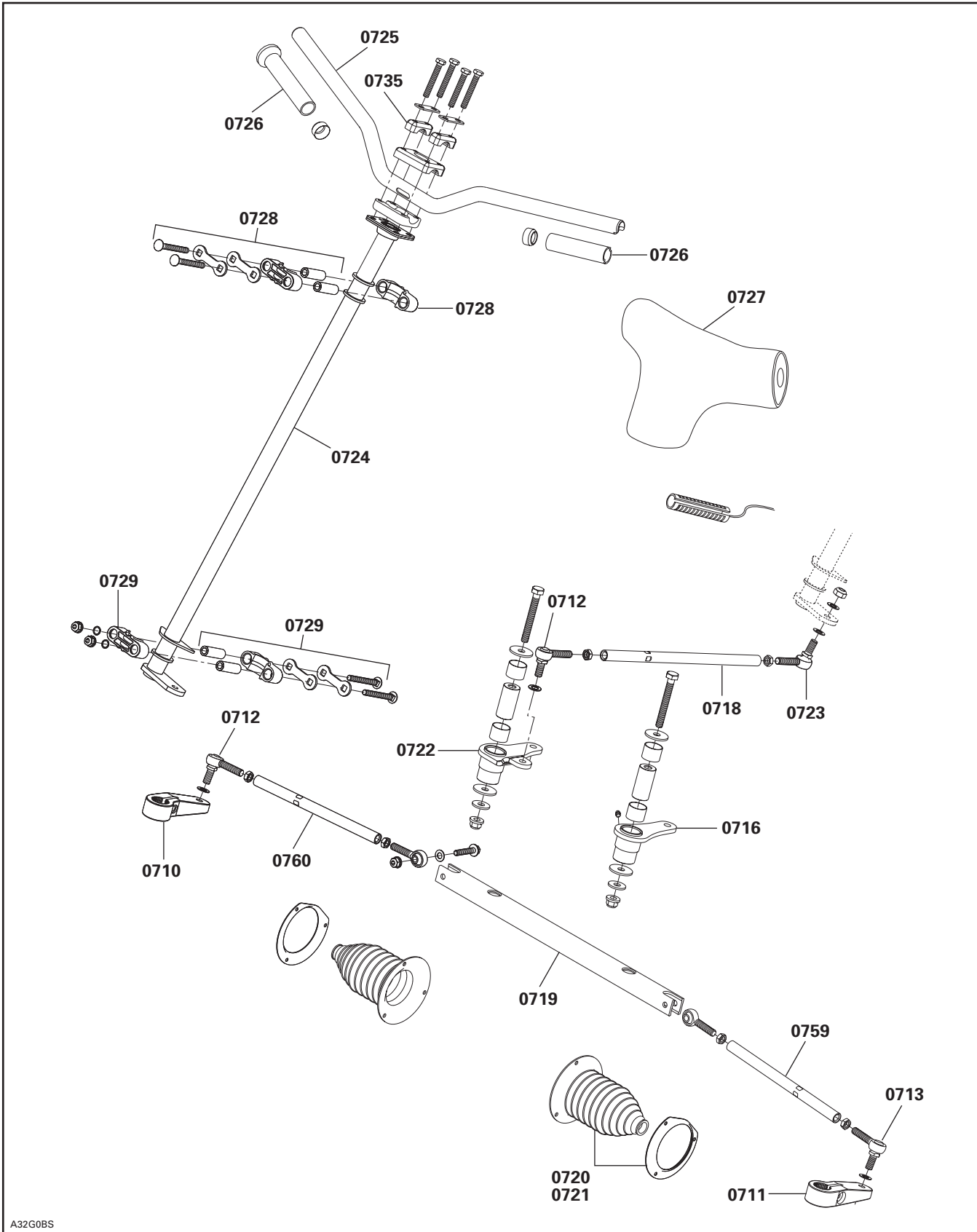

A32G0BS

REAR SUSPENSION AND TRACK SUSPENSION ARRIÈRE ET CHENILLE

08

SYSTEM/SYSTEME

SYSTEM SYSTÈME	CODE	DESCRIPTION	MINI Z	TUNDRA R	GRAND TOURING 380 F	LEGEND 380 F MX Z 380 F	SKANDIC 440 F LT	SUMMIT 550 F	GRAND TOURING 550 F	LEGEND 500 F MX Z 550 F	SKANDIC 500 F WT/SWT	SKANDIC 500 F SPORT
			1	2	3	4	5	6	7	8	9	10
08	00	NO LABOR INVOLVED AUCUNE MAIN-D'OEUVRE IMPLIQUÉE	0	0	0	0	0	0	0	0	0	0
08	01	SLIDER SHOE (1) GLISSIÈRE (1)	0.3	0.4	0.7	0.7	0.5	0.5	0.7	0.7	0.5	0.7
08	02	SLIDER SHOES (2) GLISSIÈRES (2)	0.4	0.6	1.0	1.0	0.7	0.7	1.0	1.0	0.7	1.0
08	03	RUNNER (1) PORTE-GLISSIÈRE (1)	0.4	1.2	1.2	1.2	0.9	1.2	1.2	1.2	0.9	1.2
08	04	RUNNERS (2) PORTE-GLISSIÈRES (2)	0.8	1.5	1.5	1.5	1.2	1.5	1.5	1.5	1.2	1.5
08	09	FRONT IDLER WHEEL AND/OR BEARING (1) ROUE DE SUPPORT AVANT ET/OU ROULEMENT (1)		0.3	0.3	0.3	0.3	0.3	0.3	0.3	0.3	0.3
08	10	FRONT IDLER WHEELS AND/OR BEARINGS AND/OR SHAFTS (2) ROUES DE SUPPORT AVANT ET/OU ROULEMENTS ET/OU ARBRES (2)		0.4	0.4	0.4	0.4	0.4	0.4	0.4	0.4	0.4
08	11	FRONT IDLER WHEEL SUPPORT (1) SUPPORT DE ROUE AVANT (1)			0.3	0.3		0.3	0.3	0.3		0.3
08	12	FRONT IDLER WHEELS SUPPORTS (2) SUPPORTS DE ROUE AVANT (2)			0.4	0.4		0.4	0.4	0.4		0.4
08	13	CENTER IDLER WHEEL AND/OR BEARING (1) ROUE DE SUPPORT CENTRALE ET/OU ROULEMENT (1)			0.3	0.3	0.3	0.3	0.3	0.3	0.3	0.3
08	14	CENTER IDLER WHEELS AND/OR BEARINGS AND/OR SHAFT (2) ROUES DE SUPPORT CENTRALES ET/OU ROULEMENTS ET/OU ARBRES (2)		0.4	0.4	0.4	0.3	0.4	0.4	0.4	0.3	0.4
08	15	CENTER IDLER WHEEL SUPPORT (1) SUPPORT DE ROUE CENTRALE (1)		1.2	0.3	0.3	0.3	0.3	0.3	0.3	0.3	0.3
08	16	CENTER IDLER WHEEL SUPPORTS (2) SUPPORTS DE ROUE CENTRALE (2)		1.4	0.4	0.4		0.4	0.4	0.4		0.4
08	17	REAR IDLER AND/OR BEARING (1) ROUE DE SUPPORT ARRIÈRE ET/OU ROULEMENT (1)	0.3	0.4	0.4	0.4	0.3	0.4	0.4	0.4	0.3	0.4
08	18	REAR IDLERS AND/OR BEARINGS (2) ROUES DE SUPPORT ARRIÈRE ET/OU ROULEMENTS (2)	0.3	0.5	0.5	0.5	0.4	0.5	0.5	0.5	0.4	0.5
08	19	REAR IDLER WHEELS AXLE ESSIEU DE ROUES DE SUPPORT ARRIÈRE	0.4	0.5	0.5	0.5	0.3	0.5	0.5	0.5	0.3	0.5
08	22	TAIL PIVOT IDLER WHEEL AND/OR BALL BEARING (1) (inside) ROUES DE SUPPORT PIVOT ARRIÈRE ET/OU ROULEMENT (1) (intérieur)					0.3				0.3	
08	23	TAIL PIVOT IDLER WHEELS, TWO OR AXEL ROUES DE SUPPORT PIVOT ARRIÈRE ET/OU ROULEMENTS (2) OU ESSIEUX					0.3				0.3	
08	29	AXEL (stopper strap) AXE (courroie d'arrêt)	0.3	0.3	0.3	0.3	0.3	0.3	0.3	0.3	0.3	0.3

REAR SUSPENSION AND TRACK SUSPENSION ARRIÈRE ET CHENILLE

SYSTEM SYSTÈME	CODE	DESCRIPTION	MINI Z	TUNDRA R	GRAND TOURING 380 F	LEGEND 380 F MX Z 380 F	SKANDIC 440 FLT	SUMMIT 550 F	GRAND TOURING 550 F	LEGEND 500 F MX Z 550 F	SKANDIC 500 F WT/SWT	SKANDIC 500 F SPORT
			1	2	3	4	5	6	7	8	9	10
08	30	REAR SHOCK SUPPORT SUPPORT DE L'AMORTISSEUR ARRIÈRE					0.3				0.3	
08	31	TRACK TENSION ADJUSTER (1) PLAQUE DE RÉGLAGE TENSION CHENILLE (1)		0.9	0.3	0.3		0.3	0.3	0.3		0.3
08	32	TRACK TENSION ADJUSTERS (2) PLAQUES DE RÉGLAGE TENSION CHENILLE (2)		1.3	0.4	0.4		0.4	0.4	0.4		0.4
08	33	RUNNER RUBBER STOPPER (1) BUTÉE DE CAOUTCHOUC DE PORTE-GLISSIÈRE (1)	0.3	0.3	0.3	0.3	0.3	0.3	0.3	0.3	0.3	0.3
08	34	RUNNER RUBBER STOPPERS (2) BUTÉES DE CAOUTCHOUC DE PORTE-GLISSIÈRE (2)	0.3	0.4	0.4	0.4	0.3	0.4	0.4	0.4	0.3	0.4
08	35	FRONT ARM AND/OR AXLE BRAS AVANT ET/OU ESSIEU	0.4	0.7	0.8	0.8	0.6	0.8	0.8	0.8	0.6	0.8
08	36	FRONT ARM STOPPER STRAP/STOPPER BOLT COURROIE D'ARRÊT BRAS AVANT/BOULON D'ARRÊT	0.3	0.3	0.3	0.3	0.3	0.3	0.3	0.3	0.3	0.3
08	37	FRONT ARM SUPPORT SUPPORT DE BRAS AVANT	0.4	1.5			0.6				0.6	
08	40	REAR ARM AND/OR AXLE BRAS ARRIÈRE ET/OU ESSIEU		0.4	0.7	0.7	0.5	0.7	0.7	0.7	0.5	0.7
08	41	REAR ARM IDLER WHEELS (1-2) AND/OR SHAFT-CROSS ROUES DE SUPPORT BRAS ARRIÈRE (1-2) ET/OU AXE TRANSVERSALE		0.4	0.3	0.3	0.3	0.3	0.3	0.3	0.3	0.3
08	42	REAR ARM SHACKLE JUMELLE DE BRAS ARRIÈRE		0.3	0.3	0.3	0.3	0.3	0.3	0.3	0.3	0.3
08	44	REAR AND FRONT ARMS BRAS ARRIÈRE ET AVANT		0.9	1.5	1.5	1.1	1.5	1.5	1.5	1.1	1.5
08	48	REAR TAIL PIVOT SUPPORT (1) SUPPORT DE PIVOT ARRIÈRE (1)					0.4				0.4	
08	49	REAR TAIL PIVOT SUPPORTS (2) SUPPORTS DE PIVOT ARRIÈRE (2)					0.8				0.8	
08	50	REAR TORSION SPRING AND/OR WHEEL (1) RESSORT DE TORSION ET/OU ROUE ARRIÈRE (1)		0.3	0.3	0.3	0.3	0.3	0.3	0.3	0.3	0.3
08	51	REAR TORSION SPRINGS AND/OR WHEELS (2) RESSORTS DE TORSION ET/OU ROUES (2)		0.4	0.4	0.4	0.4	0.4	0.4	0.4	0.4	0.4
08	52	TORSION SPRING SUPPORT SUPPORT DE RESSORT DE TORSION			0.3	0.3	0.3	0.3	0.3	0.3	0.3	0.3
08	53	SPRING ADJUSTMENT CAM (1) CAME DE RÉGLAGE DE RESSORT (1)		0.3	0.3	0.3	0.3	0.3	0.3	0.3	0.3	0.3
08	54	SPRING ADJUSTMENT CAMS (2) CAMES DE RÉGLAGE DE RESSORT (2)		0.4	0.4	0.4	0.4	0.4	0.4	0.4	0.4	0.4
08	55	SHOCK AND/OR SPRING AND/OR BUSHING AMORTISSEUR ET/OU RESSORT ET/OU DOUILLE		0.3	0.3	0.3	0.3	0.3	0.3	0.3	0.3	0.3

REAR SUSPENSION AND TRACK SUSPENSION ARRIÈRE ET CHENILLE

08

SYSTEM/SYSTEME

SYSTEM SYSTÈME	CODE	DESCRIPTION	MINI Z	TUNDRA R	GRAND TOURING 380 F	LEGEND 380 F MX Z 380 F	SKANDIC 440 F LT	SUMMIT 550 F	GRAND TOURING 550 F	LEGEND 500 F MX Z 550 F	SKANDIC 500 F WT/SWT	SKANDIC 500 F SPORT
			1	2	3	4	5	6	7	8	9	10

08	63	CENTER UPPER IDLER WHEELS AND/OR SHAFT (tunnel) (1 or 2) ROUES DE SUPPORT CENTRALES INTÉRIEURES ET/OU ARBRE (tunnel) (1 ou 2)	0.3	0.3	0.3	0.3		0.3	0.3	0.3		0.3
08	65	DRIVE AXLE END BEARING HOUSING LOGEMENT ROULEMENT D'EXTÉRIEUR ESSIEU MOTEUR		0.3	0.3	0.3	0.3	0.3	0.3	0.3	0.3	0.3
08	66	DRIVE AXLE BEARING AND/OR SEAL ROULEMENT D'ESSIEU MOTEUR ET/OU JOINT	0.3	1.6	1.6	1.6	0.3	1.6	1.6	1.6	0.3	1.6
08	67	DRIVE AXLE SPROCKET AND/OR FLANGE (1) ROUE DENTÉE ESSIEU MOTEUR ET/OU FLASQUE (1)	1.4	1.7	1.7	1.7	2.0	1.7	1.7	1.7	2.0	1.7
08	68	DRIVE AXLES, SPROCKETS, FLANGES (2 or more) ESSIEUX MOTEUR, ROUES DENTÉES, FLASQUES (2 ou plus)	1.5	1.9	1.9	1.9	2.4	1.9	1.9	1.9	2.4	1.9
08	69	TRACK (1) CHENILLE (1)	1.3	1.3	1.4	1.4	1.6	1.4	1.4	1.4	1.6	1.4
08	71	CLEAT AND/OR GUIDE (0-9) SEGMENT GUIDE ET/OU GUIDE (0-9)		0.3	0.3	0.3	0.3	0.3	0.3	0.3	0.3	0.3
08	72	CLEAT AND/OR GUIDE (10-14) SEGMENT GUIDE ET/OU GUIDE (10-14)		0.4	0.4	0.4	0.4	0.4	0.4	0.4	0.4	0.4
08	73	CLEAT AND/OR GUIDE (15-19) SEGMENT GUIDE ET/OU GUIDE (15-19)		0.5	0.5	0.5	0.5	0.5	0.5	0.5	0.5	0.5
08	74	CLEAT AND/OR GUIDE (20-24) SEGMENT GUIDE ET/OU GUIDE (20-24)		0.6	0.6	0.6	0.6	0.6	0.6	0.6	0.6	0.6
08	75	CLEAT AND/OR GUIDE (25-29) SEGMENT GUIDE ET/OU GUIDE (25-29)		0.7	0.7	0.7	0.7	0.7	0.7	0.7	0.7	0.7
08	76	CLEAT AND/OR GUIDE (30-34) SEGMENT GUIDE ET/OU GUIDE (30-34)		0.8	0.8	0.8	0.8	0.8	0.8	0.8	0.8	0.8
08	77	CLEAT AND/OR GUIDE (35-39) SEGMENT GUIDE ET/OU GUIDE (35-39)		0.9	0.9	0.9	0.9	0.9	0.9	0.9	0.9	0.9
08	78	CLEAT AND/OR GUIDE (40-44) SEGMENT GUIDE ET/OU GUIDE (40-44)		1.0	1.0	1.0	1.0	1.0	1.0	1.0	1.0	1.0
08	79	CLEAT AND/OR GUIDE (45-49) SEGMENT GUIDE ET/OU GUIDE (45-49)		1.1	1.1	1.1	1.1	1.1	1.1	1.1	1.1	1.1
08	80	CLEAT AND/OR GUIDE (50-54) SEGMENT GUIDE ET/OU GUIDE (50-54)		1.2	1.2	1.2	1.2	1.2	1.2	1.2	1.2	1.2
08	81	CLEAT AND/OR GUIDE (55-59) SEGMENT GUIDE ET/OU GUIDE (55-59)		1.3	1.3	1.3	1.3	1.3	1.3	1.3	1.3	1.3
08	82	CLEAT AND/OR GUIDE (60-64) SEGMENT GUIDE ET/OU GUIDE (60-64)		1.4	1.4	1.4	1.4	1.4	1.4	1.4	1.4	1.4
08	83	CLEAT AND/OR GUIDE (65-70) SEGMENT GUIDE ET/OU GUIDE (65-70)		1.5	1.5	1.5	1.5	1.5	1.5	1.5	1.5	1.5

REAR SUSPENSION AND TRACK SUSPENSION ARRIÈRE ET CHENILLE

SYSTEM SYSTÈME	CODE	DESCRIPTION	MINI Z	TUNDRA R	GRAND TOURING 380 F	LEGEND 380 F MX Z 380 F	SKANDIC 440 F LT	SUMMIT 550 F	GRAND TOURING 550 F	LEGEND 500 F MX Z 550 F	SKANDIC 500 F WT/SWT	SKANDIC 500 F SPORT
			1	2	3	4	5	6	7	8	9	10

**		DRIVE AXLE SPROCKET REPOSITION REPOSITION DE BARBOTIN D'ESSIEU		0.4	0.4	0.4	0.4	0.4	0.4	0.4	0.4	0.4
08	85	ADJUSTMENT SCREW (1) VIS D'AJUSTEMENT (1)	0.3	0.3	0.3	0.3	0.3	0.3	0.3	0.3	0.3	0.3
08	86	ADJUSTMENT SCREWS (2) VIS D'AJUSTEMENT (2)	0.3	0.4	0.4	0.4	0.4	0.4	0.4	0.4	0.4	0.4
08	87	SHOCK SUPPORT AND/OR AXLE SUPPORT D'AMORTISSEUR ET/OU AXE			0.4	0.4		0.4	0.4	0.4		0.4
08	88	FRONT SHOCK AND OR SPRING AMORTISSEUR AVANT ET OU RESSORT			0.5	0.5		0.5	0.5	0.5		0.5
08	89	FRONT IDLER WHEELS AND/OR BEARING (3/4) ROUE DE SUPPORT AVANT ET/OU ROULEMENT (3/4)		0.6	0.5	0.5	0.5	0.5	0.5	0.5	0.5	0.5
08	90	FRONT IDLER WHEELS AND/OR BEARING (5/16) ROUE DE SUPPORT AVANT ET/OU ROULEMENT (5/16)			0.7	0.7	0.7	0.7	0.7	0.7	0.7	0.7
08	91	REAR PIVOT ARM BRAS DE PIVOT ARRIÈRE					0.4				0.4	
08	92	FRONT TORSION SPRING (1) RESSORT DE TORSION AVANT (1)	0.3				0.3				0.3	
08	93	FRONT TORSION SPRINGS (2) RESSORTS DE TORSION AVANT (2)	0.3				0.4				0.4	
08	94	FRONT IDLER WHEELS (inside) ROUES DE SUPPORT AVANT (intérieur)		1.0	1.0	1.0		1.0	1.0	1.0		1.0
08	97	FRONT STOPPER STRAP COURROIE AVANT D'ARRÊT	0.3									
08	98	DRIVE AXEL (LH) BEARING ROULEMENT SUPPORT AVANT (G)	1.3									
08	99	SPEEDOMETER DRIVE INSERT PRISE D'INDICATEUR DE VITESSE			0.4	0.4	0.4	0.4	0.4	0.4	0.4	0.4

Rear Suspension Mini Z/Suspension arrière Mini Z

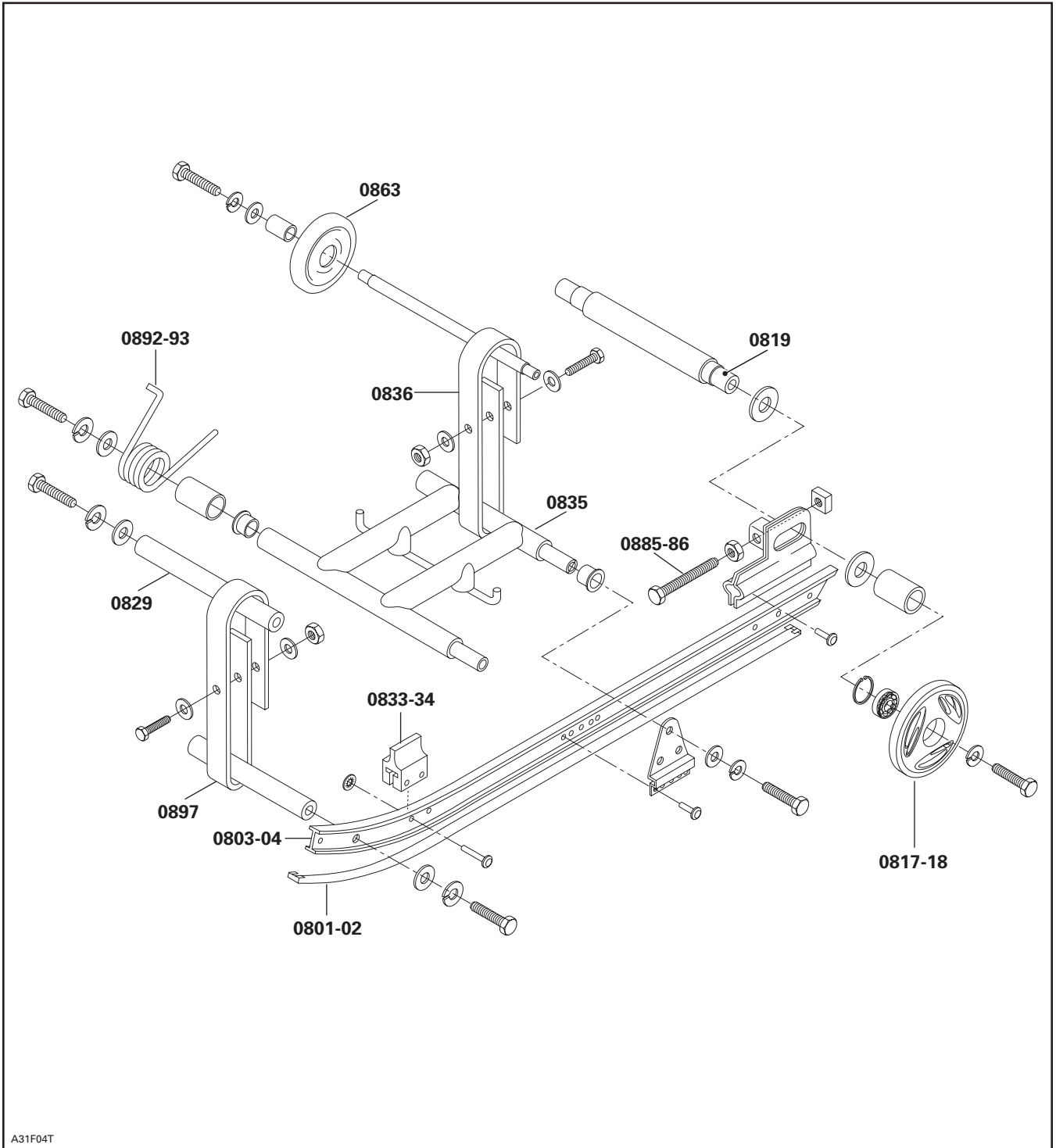

Rear Suspension Mini Z/Suspension arrière Mini Z

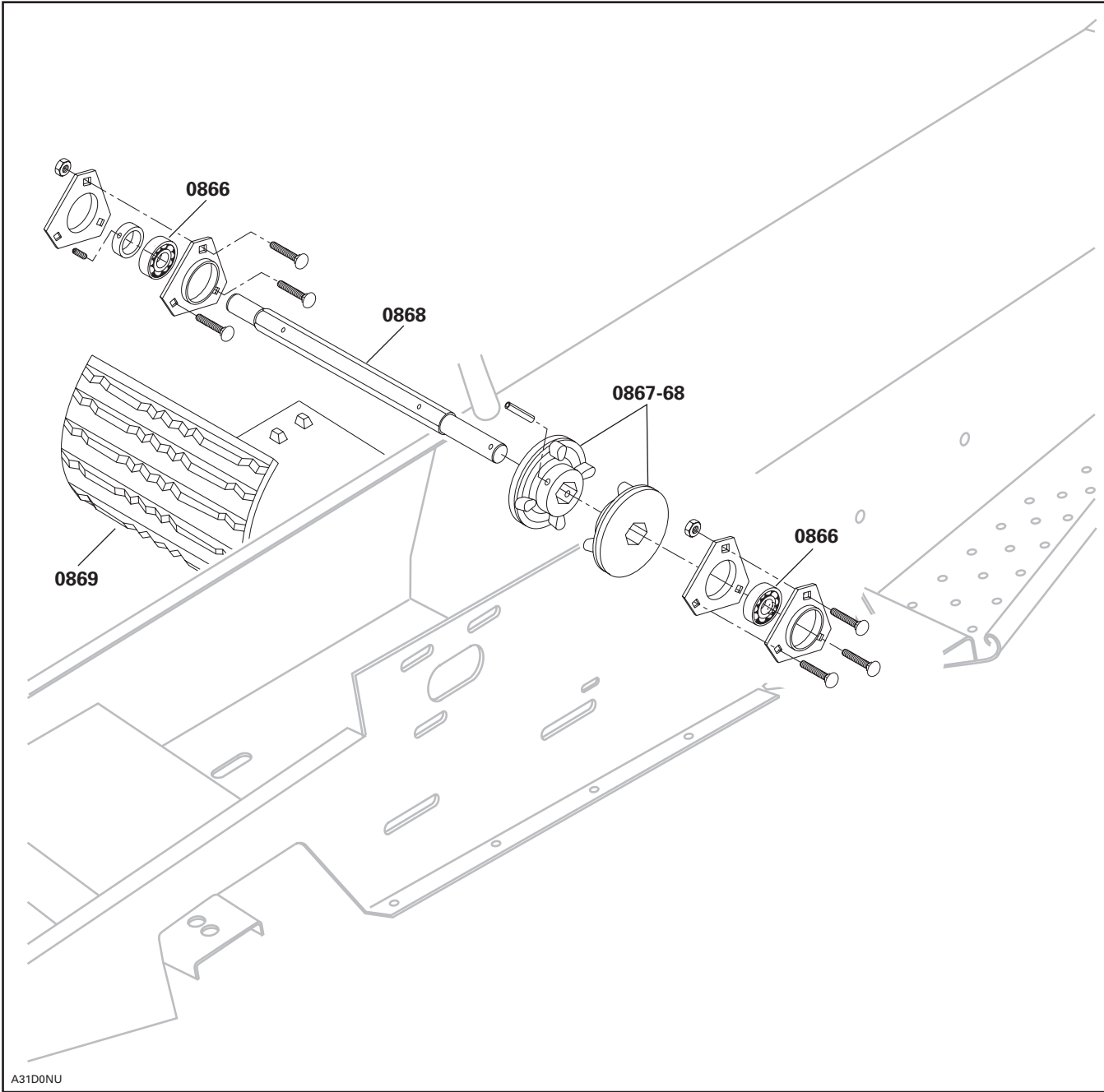

A31D0NU

REAR SUSPENSION AND TRACK SUSPENSION ARRIÈRE ET CHENILLE

08
SYSTEM/SYSTEME

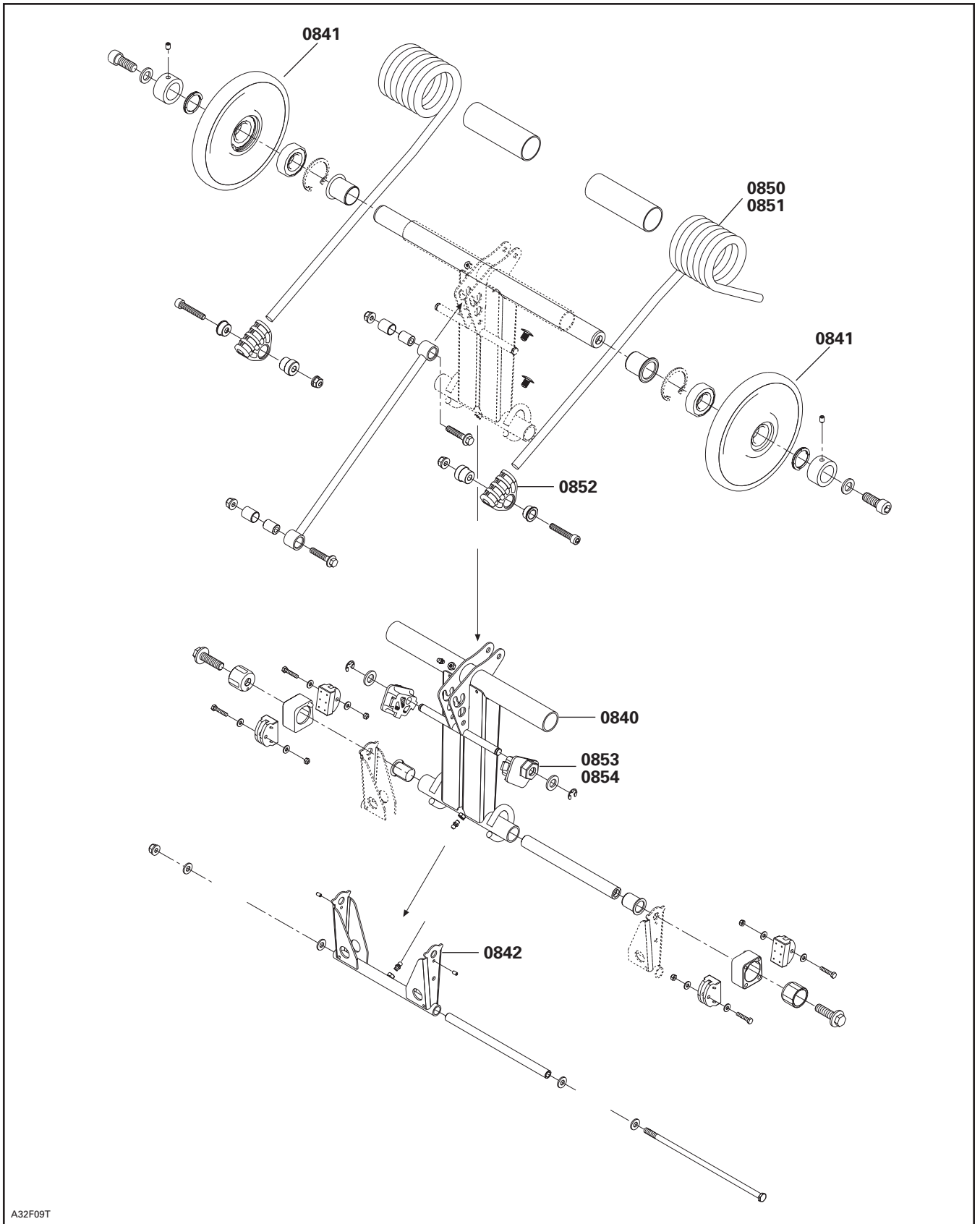

A32F09T

REAR SUSPENSION AND TRACK SUSPENSION ARRIÈRE ET CHENILLE

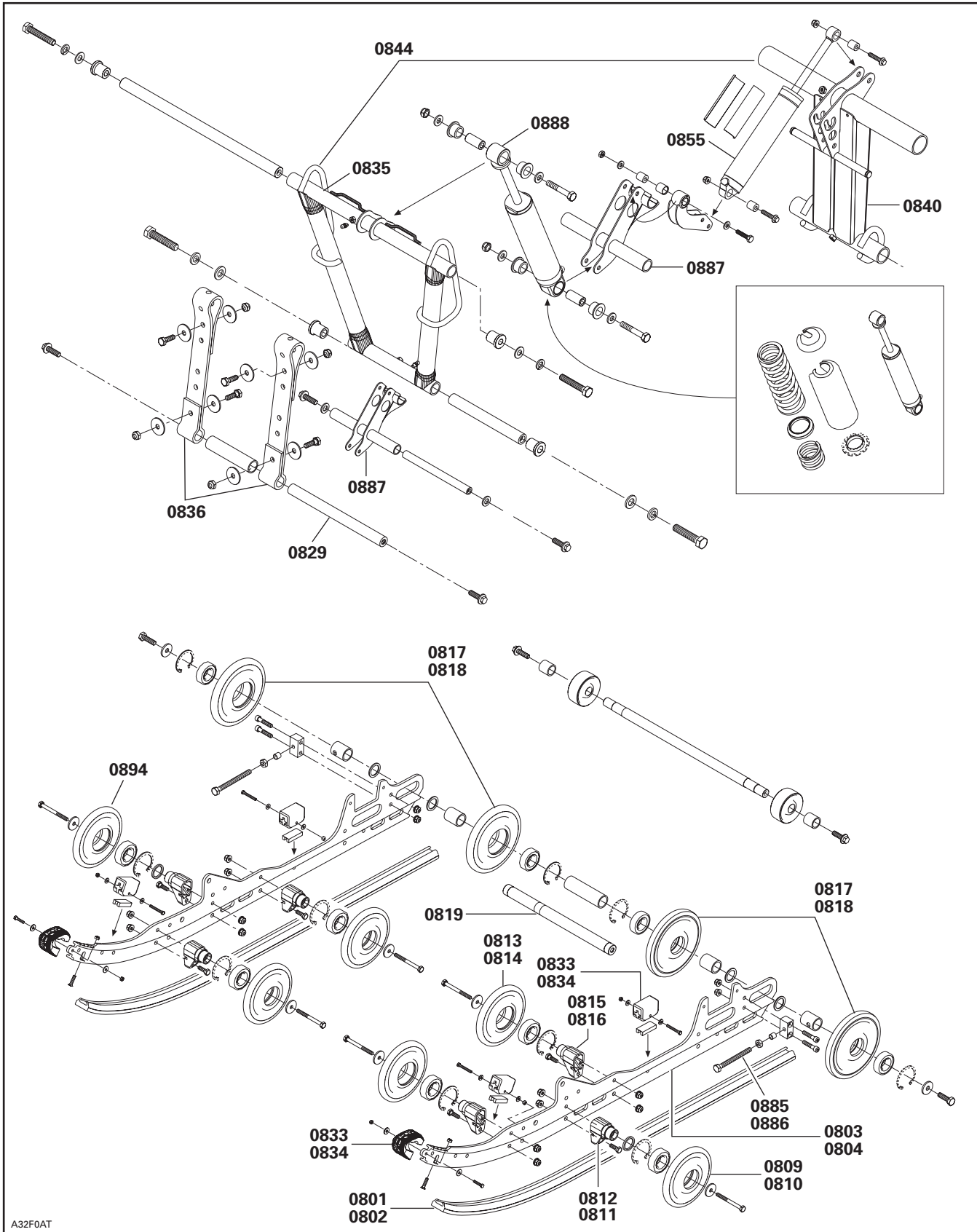

REAR SUSPENSION AND TRACK SUSPENSION ARRIÈRE ET CHENILLE

08
SYSTEM/SYSTEME

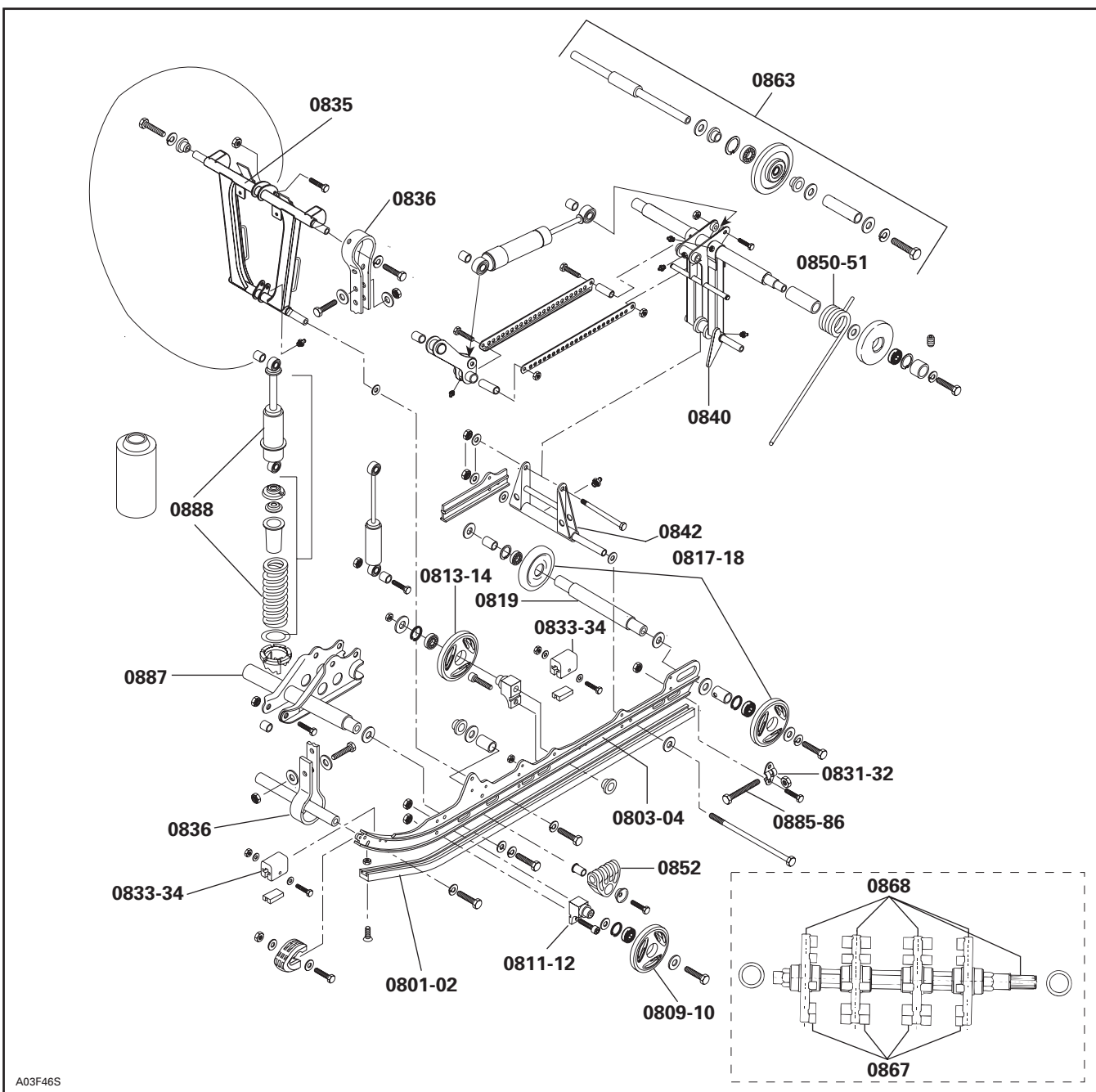

A03F46S

SYSTEM SYSTÈME	CODE	DESCRIPTION	MINI Z	TUNDRA R	GRAND TOURING 380 F	LEGEND 380 F MX Z 380 F	SKANDIC 440 F LT	SUMMIT 550 F	GRAND TOURING 550 F	LEGEND 500 F MX Z 550 F	SKANDIC 500 F WT/SWT	SKANDIC 500 F SPORT
			1	2	3	4	5	6	7	8	9	10
09	00	NO LABOR INVOLVED AUCUNE MAIN-D'OEUVRE IMPLIQUÉE	0	0	0	0	0	0	0	0	0	0
09	01	CAB OR HOOD CABINE OU CAPOT	0.9	1.0	3.0	3.0	2.5	3.0	3.0	3.0	3.0	3.0
09	03	CAB HINGE TRIM AND/OR HINGE GARNITURE CHARNIÈRE CABINE ET/OU CHARNIÈRE		0.7	0.3	0.3	0.3	0.3	0.3	0.3		0.3
09	05	CAB DECALS RH OR LH AUTOCOLLANTS GAUCHE/DROITE DE CABINE	0.3	0.3	0.3	0.3	0.3	0.3	0.3	0.3	0.3	0.3
09	06	CAB DECALS ALL TOUS LES AUTOCOLLANTS DE LA CABINE	0.7	0.5	0.9	0.9	0.9	0.9	0.9	0.9	0.7	0.9
09	07	CAB LATCH (1 or 2) ATTACHE DE LA CABINE (1 ou 2)	0.3	0.3	0.3	0.3	0.3	0.3	0.3	0.3	0.3	0.3
09	09	WINDSHIELD PARE-BRISE	0.3	0.3	0.3	0.3	0.3	0.3	0.3	0.3	0.3	0.3
09	10	SPEEDOMETER OR TACHOMETER (all parts) INDICATEUR VITESSE OU COMPTE-TOURS (toutes pièces)			0.3	0.3	0.3	0.3	0.3	0.3	0.3	0.3
09	12	SPEEDOMETER DRIVE INSERT PRISE D'INDICATEUR DE VITESSE			0.4	0.4	0.4	0.4	0.4	0.4	0.4	0.4
09	13	CARGO RACK SUPPORT À BAGAGES		0.3	0.4		0.4		0.4			0.4
09	14	FRONT BUMPER (OUTS CAB) AND/OR SEAL PARE-CHOCS AVANT (EXT. CAB) ET/OU JOINT ÉTANCHÉITÉ	0.3	0.3	0.4	0.4	0.4	0.4	0.4	0.4	0.6	0.4
09	16	FRONT BUMPER CAP (LH or RH) EXTRÉMITÉ DE PARE-CHOCS AVANT (G ou D)		0.3							0.3	
09	17	CONSOLE CONSOLE			1.2	1.2	1.2	1.2	1.2	1.2	1.2	1.2
09	18	FUEL TANK AND/OR SENDER RÉSERVOIR D'ESSENCE ET/OU SONDE	0.2	0.3	0.3	0.3	0.3	0.3	0.3	0.3	0.3	0.3
09	19	FUEL TANK CAP BOUCHON DU RÉSERVOIR D'ESSENCE	0.3	0.3	0.3	0.3	0.3	0.3	0.3	0.3	0.3	0.3
09	20	FUEL TANK GROMMET RONDELLE ISOLANTE DE RÉSERVOIR D'ESSENCE	0.3	0.3	0.3	0.3	0.3	0.3	0.3	0.3	0.3	0.3
09	21	SEAT ASS'Y OR BACKREST SIÈGE COMPLET OU DOSSIER	0.3	0.3	0.3	0.3	0.3	0.3	0.3	0.3	0.3	0.3
09	22	SEAT COVER HOUSSE DE SIÈGE	1.1	0.6	1.2	1.0	1.0	1.0	1.2	1.0	1.2	1.2
09	23	FOAM FOR SEAT CAOUTCHOUC MOUSSE DE SIÈGE	1.1	0.6	1.2	1.0	1.0	1.0	1.2	1.0	1.2	1.2
09	24	BOTTOM PAN COQUE		2.6	2.0	2.0	2.0	2.0	2.0	2.0	2.0	2.0
09	30	REAR FOOTREST REPOSE-PIED ARRIÈRE			0.3				0.3			

SYSTEM SYSTÈME	CODE	DESCRIPTION	MINI Z	TUNDRA R	GRAND TOURING 380 F	LEGEND 380 F MX Z 380 F	SKANDIC 440 F LT	SUMMIT 550 F	GRAND TOURING 550 F	LEGEND 500 F MX Z 550 F	SKANDIC 500 F WT/SWT	SKANDIC 500 F SPORT
			1	2	3	4	5	6	7	8	9	10

09	34	REAR BUMPER PARE-CHOC ARRIÈRE		0.3	0.3	0.3		0.3	0.3	0.3		0.3
09	35	HITCH SUPPORT (all parts) SUPPORT D'ATTELAGE (toutes les pièces)		0.3	0.3		0.3		0.3		0.3	0.3
09	37	HANDLE STEERING SUPPORT SUPPORT DE GUIDON			0.5	0.5	0.5	0.5	0.5	0.5		0.5
09	40	BUMPER DECALS OR MOULDING AUTOCOLLANTS OU MOULURE DU PARE-CHOC				0.3						
09	42	MOULDING (LH or RH) MOULURE (G ou D)			0.3	0.3		0.3	0.3	0.3		0.3
09	48	FRONT FOOTREST (LH or RH) REPOSE-PIED AVANT (G ou D)			0.4	0.4		0.4	0.4	0.4		0.4
09	49	FRAME ASS'Y OR FRONT MEMBER CHÂSSIS COMPLET OU CADRE AVANT	5.7	6.3	9.0	9.0	8.0	9.0	9.0	9.0	7.0	9.0
09 *	50	FRAME FORMING (tunnel) TUNNEL			10.6	10.6		10.6	10.6	10.6		10.6
09	51	REAR FRAME PARTIE ARRIÈRE DU CHÂSSIS			0.7	0.7		0.7	0.7	0.7		0.7
09	52	SIDE BRACKET (RH or LH) SUPPORT LATÉRAL (G ou D)			0.7	0.7		0.7	0.7	0.7		0.7
09	55	SNOW GUARD (1) GARDE-NEIGE (1)	0.3	0.3	0.3	0.3	0.3	0.3	0.3	0.3	0.3	0.3
09	58	BACKREST AND/OR COVER DOSSIER ET/OU HOUSSE			0.3				0.3		0.3	0.3
09	60	FUEL FILTER FILTRE DE CARBURANT		0.3	0.3	0.3	0.3	0.3	0.3	0.3	0.3	0.3
09	61	CAB HINGE SUPPORTS (2) SUPPORTS DE PENTURE DU CAPOT (2)			0.7	0.7	0.7	0.7	0.7	0.7		0.7
09	62	BOTTOM PAN REINFORCEMENT (RH) RENFORT DE COQUE (D)			0.4	0.4		0.4	0.4	0.4		0.4
09	63	BOTTOM PAN REINFORCEMENT (LH) RENFORT DE COQUE (G)			0.6	0.6		0.6	0.6	0.6		0.6
09	64	SEAT BELT COURROIE DE SIÈGE			0.3		0.3		0.3		0.3	0.3
09	65	MIRROR (1) RÉTROVISEUR (1)		0.3		0.3	0.3	0.3			0.3	0.3
09	66	MIRRORS (2) RÉTROVISEURS (2)		0.3		0.3	0.3	0.3			0.3	0.3

SYSTEM SYSTÈME	CODE	DESCRIPTION	MINI Z	TUNDRA R	GRAND TOURING 380 F	LEGEND 380 F MX Z 380 F	SKANDIC 440 F LT	SUMMIT 550 F	GRAND TOURING 550 F	LEGEND 500 F MX Z 550 F	SKANDIC 500 F WT/SWT	SKANDIC 500 F SPORT
			1	2	3	4	5	6	7	8	9	10

09	68	HOOD GUIDE (RH or LH) GUIDE DE CAPOT (G ou D)		0.3	0.3	0.3	0.3	0.3	0.3	0.3	0.3	0.3
09	69	CAB HINGE SUPPORT (1) SUPPORT DE CHARNIÈRE DE CABINE (1)					0.6				0.3	
09	70	HOOD LATCH (1 or 2) LOQUET DE CAPOT (1 ou 2)	0.3									
09	72	TUNNEL DECAL (1 or 2) DÉCALQUE DE TUNNEL (1 ou 2)					0.3				0.3	
09	77	BOTTOM PAN (RH) COQUE (D)	0.6									
09	78	BOTTOM PAN (LH) COQUE (G)	0.9									
09	79	CENTER BOTTOM PAN COQUE PARTIE CENTRALE	0.8									
09	80	FRONT GRILL (RH and/or LH) GRILLE AVANT (G et/ou D)	0.3		0.3	0.3	0.3	0.3	0.3	0.3	0.3	0.3
09	81	SIDE GRILL (RH and/or LH) GRILLE LATÉRAL (G et/ou D)	0.3		0.3	0.3	0.3	0.3	0.3	0.3	0.3	0.3

SYSTEM SYSTÈME	CODE	DESCRIPTION	MINI Z	TUNDRA R	GRAND TOURING 380 F	LEGEND 380 F MX Z 380 F	SKANDIC 440 F LT	SUMMIT 550 F	GRAND TOURING 550 F	LEGEND 500 F MX Z 550 F	SKANDIC 500 F WT/SWT	SKANDIC 500 F SPORT
			1	2	3	4	5	6	7	8	9	10

10	00	NO LABOR INVOLVED AUCUNE MAIN-D'OEUVRE IMPLIQUÉE	0	0	0	0	0	0	0	0	0	0
10	01	IGNITION SWITCH INTERRUPTEUR D'ALLUMAGE	0.3	0.3	0.3	0.3	0.3	0.3	0.3	0.3	0.3	0.3
10	02	DIMMER SWITCH COMMUTATEUR D'ÉCLAIRAGE		0.3	0.3	0.3	0.3	0.3	0.3	0.3	0.3	0.3
10	03	KILL SWITCH INTERRUPTEUR D'URGENCE		0.3	0.3	0.3	0.3	0.3	0.3	0.3	0.3	0.3
10	05	BRAKE LIGHT SWITCH INTERRUPTEUR DE FEU D'ARRÊT		0.3	0.3	0.3	0.3	0.3	0.3	0.3	0.3	0.3
10	06	TETHER CORD SWITCH CAPUCHON COUPE-CIRCUIT	0.3	0.3	0.3	0.3	0.3	0.3	0.3	0.3	0.3	0.3
10	07	IGNITION SWITCH BLOCK LOGEMENT DE RÉCEPTACLE (interrupteur)	0.3	0.3	0.3	0.3	0.3	0.3	0.3	0.3	0.3	0.3
10	08	CURRENT OR GROUND WIRE FIL DE BATTERIE OU DE MASSE			0.3	0.3		0.3	0.3	0.3	0.3	0.3
10	09	HEADLAMP ASS'Y (any/or all parts) PHARE (toutes les pièces)	0.3	0.3	0.3	0.3	0.3	0.3	0.3	0.3	0.3	0.3
10	10	VOLTAGE REGULATOR RÉGULATEUR DE TENSION		0.3	0.3	0.3	0.3	0.3	0.3	0.3	0.3	0.3
10	11	RECTIFIER REDRESSEUR			0.3	0.3		0.3	0.3	0.3	0.3	0.3
10	12	TAIL LIGHT ASS'Y (any/or all parts) FEU ARRIÈRE (toutes les pièces)	0.3	0.3	0.3	0.3		0.3	0.3	0.3	0.3	0.3
10	13	BATTERY RACK, RETAINER ROD AND/OR RETAINER BATTERIE SUPPORT, TIGE RETENUE ET/OU COUVERCLE RETENU			0.3	0.3		0.3	0.3	0.3	0.3	0.3
10	15	HEATED GRIPS POIGNÉES CHAUFFANTES			0.4	0.4	0.4	0.4	0.4	0.4	0.4	0.4
10	16	BULBS (any or all) AMPOULES (1 ou toutes)	0.3	0.3	0.3	0.3	0.3	0.3	0.3	0.3	0.3	0.3
10	17	HEATED THROTTLE LEVER MANETTE D'ACCÉLÉRATEUR CHAUFFANTE			0.3	0.3	0.3	0.3	0.3	0.3	0.3	0.3
10	18	HEAT GRIP SWITCH (1) INTERRUPTEUR (poignée/manette d'accélérateur chauffante) (1)			0.3	0.3	0.3	0.3	0.3	0.3	0.3	0.3
10	19	HEAT GRIP SWITCHES (2) INTERRUPTEURS (poignée/manette d'accélérateur chauffante) (2)			0.4	0.4		0.4	0.4	0.4		0.4
10	20	BACK UP BUZZER AVERTISSEUR DE MARCHE ARRIÈRE		0.3	0.3	0.3	0.3	0.3	0.3	0.3	0.3	0.3

SYSTEM SYSTÈME	CODE	DESCRIPTION	MINI Z	TUNDRA R	GRAND TOURING 380 F	LEGEND 380 F MX Z 380 F	SKANDIC 440 FLT	SUMMIT 550 F	GRAND TOURING 550 F	LEGEND 500 F MX Z 550 F	SKANDIC 500 F WT/SWT	SKANDIC 500 F SPORT
			1	2	3	4	5	6	7	8	9	10
10	27	REVERSE KNOB BOUTON DE MARCHE ARRIÈRE		0.3	0.3	0.3	0.3	0.3	0.3	0.3	0.3	0.3
10	34	ELECTRONIC MODULE MODULE ÉLECTRONIQUE		0.3	0.3	0.3	0.3	0.3	0.3	0.3	0.5	0.3

CLAIM TYPE 02
RÉCLAMATION DE TYPE 02

SYSTEM SYSTEME	CODE	DESCRIPTION	MINI Z	TUNDRA R	GRAND TOURING 380 F	LEGEND 380 F MX Z 380 F	SKANDIC 440 FLT	SUMMIT 550 F	GRAND TOURING 550 F	LEGEND 500 F MX Z 550 F	SKANDIC 500 F WT/SWT	SKANDIC 500 F SPORT
			1	2	3	4	5	6	7	8	9	10
11	00	NO LABOR INVOLVED AUCUNE MAIN-D'OEUVRE IMPLIQUÉE	0	0	0	0	0	0	0	0	0	

FLAT RATE TIME SUGGESTION

DEALER'S NO.: _____ DATE: _____

DEALER'S NAME: _____

FILE IDENTIFICATION NO.: _____

ADDRESS: _____

YEAR	MODEL DESCRIPTION	OPERATION	JOB CODE	PRESENT FLAT RATE	SUGGESTED FLAT RATE

Detailed procedure used:

Signature: _____

BOMBARDIER
RECREATIONAL PRODUCTS
WARRANTY DEPARTMENT
75, J.A. BOMBARDIER ST.
SHERBROOKE (QUEBEC)
CANADA, J1L 1W3

FAX NUMBER: 819-566-3590

**BARÈME DE TEMPS À TAUX FIXE
SUGGESTION**

N° DU CONCESSIONNAIRE: _____ DATE: _____

NOM DU CONCESSIONNAIRE: _____

N° D'IDENTIFICATION DU DOSSIER: _____

ADRESSE: _____

ANNÉE	DESCRIPTION DU MODÈLE	OPÉRATION	CODE DE TRAVAUX	TTP ACTUEL	TTP SUGGÉRÉ

Détails de la marche à suivre:

Signature: _____

BOMBARDIER
PRODUITS RÉCRÉATIF

SERVICE DE GARANTIE
75, RUE J.-A. BOMBARDIER
SHERBROOKE (QUÉBEC)
CANADA, J1L 1W3

N° DU TÉLÉCOPIEUR: 819-566-3590