

ski-doo®

FLAT RATE Time Schedule BARÈME DE TEMPS à taux fixe 2003

Volume 5

MX Z

800 X / R
800 Adrénaline R
800 Renegade R
800 Sport

LEGEND

800 SE / SDI

SUMMIT

800 HM X / R
800 HM / R
800 X / R

800 Adrénaline /R

GRAND TOURING

800 SE / SDI

Effective November 22th, 2002
En vigueur le 22 novembre 2002

™&® ARE TRADEMARKS AND ® ARE REGISTERED TRADEMARKS OF BOMBARDIER INC. OR ITS SUBSIDIARIES.
© 2002 BOMBARDIER INC. ALL RIGHTS RESERVED.
PRINTED IN CANADA

™&® SONT DES MARQUES DE COMMERCE ET ® SONT DES MARQUES DÉPOSÉES DE BOMBARDIER INC. OU SES FILIALES.
© 2002 BOMBARDIER INC. TOUS DROITS RÉSERVÉS.
IMPRIMÉ AU CANADA



INTRODUCTION

This publication governs all warranty labor allowances for 2003 Bombardier Snowmobiles.

1. HOW DOES IT WORK

We follow the procedures detailed in the Bombardier *Snowmobiles Shop Manual*. The flat rate time is the maximum time allowed for a repair involving any given part. **FLAT RATE TIME IS NOT CUMULATIVE.** You must use the flat rate time given for the longest lasting operation.

NOTE: The *Flat Rate Time Schedule* was prepared by skilled mechanics using the hand tool usually found in workshops and all the special tools mentioned in the *Shop Manual*.

2. COMPILATION

The *Flat Rate Time Schedule* is compiled as follows:

The actual required time to perform the repair plus (+) 30% correction factor up to 3.0 hours or (+) 15% over 3.0 hours time to take into account, among others:

- vehicle handling
- obtaining the parts
- diagnosis
- cleaning
- special compensation (rusted bolts).

3. HOW TO USE IT

Refer to the system you need, locate part of series of parts replaced. List JOB CODE in the appropriate column on claim.

SYSTEM		PAGE
01	ENGINE	5
02	CARBURETOR AND OIL INJECTION SYSTEM	10
03	IGNITION SYSTEM	19
04	STARTER	21
05	TRANSMISSION SYSTEM	23
06	BRAKE SYSTEM	28

SYSTEM		PAGE
07	STEERING SYSTEM AND FRONT SUSPENSION	30
08	REAR SUSPENSION AND TRACK	36
09	BODY	41
10	ELECTRICAL SYSTEM	47
11	CLAIM TYPE 02	48

NOTE: Unless otherwise specified, dismantling order is: top to bottom, exterior to interior, front to rear.

All fractions of hours are in tenths:

0.1 = 6 minutes

0.2 = 12 minutes, and so on

LEGEND:

- * REQUIRES PRIOR AUTHORIZATION BY DISTRIBUTOR.
- ** INDICATE LABOUR TIME ON LINE "LABOUR ONLY" OF CLAIM.
- *** INDICATE \$\$\$ AMOUNT ON "SUB-CONTRACTED LABOUR" OF CLAIM.

IMPORTANT: Always use the longest flat rate time applicable to the repair performed.

4. JOB REQUIREMENTS

All the flat rate times mentioned in the following pages include the required operations such as: engine timing (rotary valve and ignition), connecting rod(s) alignment, cylinder head(s) torque or use of parallel bar, use of ignition tester, piston clearance/ring end gap measurement, crankshaft to crankcase measurement, cylinder honing, engine leak test.

5. ILLUSTRATIONS

The illustrations contained in this manual do not necessarily show every components of a given system as *Parts Catalog* do. Their purpose is to facilitate recognition of parts related to a flat rate time. **Item numbers on illustrations correspond to the four digit Job Code.**

6. SUGGESTION (form request)

INTRODUCTION

Cette publication détermine le temps de main d'oeuvre couvert par la garantie pour les motoneiges Bombardier 2003.

1. UTILISATION DU MANUEL

En procédant de la façon indiquée dans le *Manuel de réparation motoneiges* Bombardier, chaque temps donné représente le maximum permis pour une réparation portant sur cette pièce. **LES TEMPS NE SONT PAS CUMULATIFS.** On doit inscrire le temps donné pour l'opération qui prend le plus de temps.

REMARQUE: Le *Barème de temps à taux fixe* a été préparé par des mécaniciens compétents utilisant les outils que l'on retrouve normalement dans les ateliers de réparation, en plus de tous les outils spéciaux mentionnés dans le *Manuel de réparation*.

2. COMPILATION

Le *Barème de temps à taux fixe* a été établi en compilant le temps nécessaire pour faire la réparation plus (+) un facteur de correction de 30% lorsqu'un travail dure 3.0 heures et moins, ou (+) 15% lorsqu'un travail dure plus de 3.0 heures. Cette compilation comprends, entre autres les étapes suivantes:

- manutention du véhicule
- nettoyage
- aller chercher les pièces, essais physique
- compensation spéciale (boulons rouillés)
- diagnostic.

3. UTILISATION DU BARÈME

Se reporter à la section désirée, repérer la pièce ou l'ensemble de pièces remplacées et inscrire le CODE DE TRAVAIL dans la colonne appropriée sur la formule de réclamation.

SYSTÈME		PAGE
01	MOTEUR	5
02	CARBURATEUR ET SYSTÈME D'INJECTION D'HUILE	10
03	SYSTÈME D'ALLUMAGE	19
04	DÉMARREUR	21
05	SYSTÈME DE TRANSMISSION	23
06	SYSTÈME DE FREIN	28

SYSTÈME		PAGE
07	SYSTÈME DE DIRECTION ET SUSPENSION AVANT	30
08	SUSPENSION ARRIÈRE ET CHENILLE	36
09	CARROSSERIE	41
10	SYSTÈME ÉLECTRIQUE	47
11	RÉCLAMATION DE TYPE 02	48

REMARQUE: Sauf indication contraire, le démontage doit s'effectuer de haut en bas, de l'extérieur vers l'intérieur, de l'avant vers l'arrière.

Toutes les fractions d'heures sont exprimées en dixièmes:

0.1 = 6 minutes

0.2 = 12 minutes, et ainsi de suite

LÉGENDE:

* AUTORISATION REQUISE AVANT LE REMPLACEMENT.

** INSCRIRE LE TEMPS À LA LIGNE «MAIN D'OEUVRE SEULEMENT».

*** INSCRIRE LE MONTANT \$\$\$ À LA LIGNE «OUVRAGE SOUS-CONTRACTÉE».

IMPORTANT: Toujours utiliser le temps donné à l'opération qui nécessite le plus de temps.

4. TRAVAUX REQUIS

Tous les temps mentionnés dans les pages suivantes incluent les opérations telles que: réglage du moteur (valve rotative et allumage), alignement de la ou des bielles, couple de serrage de la ou des culasses ou l'utilisation de barres parallèles, utilisation du vérificateur d'allumage, mesure du jet des pistons/jeu en bout des segments, mesure de l'écart entre le vilebrequin et le carter, rectification du cylindre, vérification de fuite du moteur.

5. ILLUSTRATIONS

Contrairement aux *Catalogues de pièces*, les illustrations de ce manuel ne montrent pas nécessairement chacune des pièces qu'elles représentent, leur raison d'être étant plutôt de faciliter la reconnaissance des pièces reliées à un barème de temps à taux fixe. **Les numéros d'items sur les illustrations correspondent aux quatre derniers chiffres du code de travail.**

6. SUGGESTION DE CHANGEMENT (formulaire)

2003

LIQUID COOLED TWIN CYLINDERS- 2 CYLINDRES REFROIDIS PAR LIQUIDE

TABLE	DESCRIPTION	MODEL/MODÈLE	ENGINE/MOTEUR	CHASSIS TYPE/ TYPE DE CHÂSSIS	REVERSE/ MARCHE ARRIÈRE	REAR SUSPENSION/ SUSPENSION ARR.	ELECT. STARTER/ DÉMARREUR ÉLECT.	DRIVE PULLEY/ POULIE MOTRICE	DRIVEN PULLEY/ POULIE MÈNÉE
28	MX Z 800 X R (CDN/US)	2228/2229 2230/2231 2611/2648 2650/2651 2652/2653 2654/2655 2656/2657 2674/2677	793	REV	R.E.R	SC10-III	OPT	TRA III	HPV27
	MX Z 800 Sport	2259/2260 2265/2266	793	REV	OPT	SC10-III	OPT	C.D T.R.A.C.	Formula
	MX Z 800 Sport R	2267/2268 2269/2270 2271/2272 2273/2274 2275/2276 2277/2278 2279/2280 2281/2282 2663/2664 2665/2668 2669	793	REV	R.E.R	SC10-III	OPT STD	C.D T.R.A.C.	HPV27
29	MX Z 800 Adrenaline	2306/2307	793	ZX-X	OPT	SC10-III	OPT	C.D T.R.A.C.	HPV27
	MX Z 800 Adrenaline R	2310/2311 2312/2314 2315/2316 2317/2577 2578/2579	793	ZX-X	R.E.R	SC10-III	OPT STD	C.D T.R.A.C.	HPV27
	MX Z 800 Renegade	2390/2391	793	ZX-X	OPT	SC10-III	OPT STD	C.D T.R.A.C.	HPV27
	MX Z 800 Renegade R	2394/2395 2396/2397 2398/2399 2400/2601 2602/2603 2604	793	ZX-X	R.E.R	SC10-II	OPT STD	C.D T.R.A.C.	HPV27
	MX Z 800 Renegade R (EUR)	2619							
30	Legend 800 SDI SE	2372/2373 2374/2375 2642/2643	793	ZX	R.E.R	SC10-II	STD	C.D T.R.A.C.	HPV27

TABLA	DESCRIPTION	MODEL/MODÈLE	ENGINE/MOTEUR	CHASSIS TYPE/ TYPE DE CHÂSSIS	REVERSE/ MARCHE ARRIÈRE	REAR SUSPENSION/ SUSPENSION ARR.	ELECT. STARTER/ DÉMARREUR ÉLECT.	DRIVE PULLEY/ POULIE MOTRICE	DRIVEN PULLEY/ POULIE MÈNÉE
31	Summit 800 HM X	2526/2527 2528/2538 2539/2540	793	ZX-X	OPT	SC10-M	OPT	C.D T.R.A.C.	Formula
	Summit 800 HM X R	2532/2533 2534/2535 2536/2537	793	ZX-X	R.E.R	SC10-M	OPT	C.D T.R.A.C.	HPV27
	Summit 800 HM	2541/2542	793	ZX-X	OPT	SC10-M	OPT	C.D T.R.A.C.	Formula
	Summit 800 HM R	2547/2548 2549/2550	793	ZX-X	R.E.R	SC10-M	OPT	C.D T.R.A.C.	HPV27
32	Summit 800 X	2456/2457 2458	793	ZX-X	OPT	SC10-M	OPT	C.D T.R.A.C.	Formula
	Summit 800 X R (EUR)	2629	793	ZX-X	OPT	SC10-M	OPT	C.D T.R.A.C.	Formula
	Summit 800 X R	2465/2466 2467/2468 2469/2470	793	ZX-X	R.E.R	SC10-M	OPT	C.D T.R.A.C.	HPV27
	Summit 800 Adrenaline	2483/2484	793	ZX-X	OPT	SC10-M	OPT	C.D T.R.A.C.	Formula
	Summit 800 Adrenaline R	2489/2490 2491/2494	793	ZX-X	R.E.R	SC10-M	OPT	C.D T.R.A.C.	HPV27
33	Grand Touring 800 SDI SE	2426/2428 2645/2646	793	ZX	R.E.R	SC10-II LT	STD	C.D T.R.A.C.	HPV27
	Grand Touring 800 SDI SE (EUR)	2621	793	ZX	R.E.R	SC10-II LT	STD	C.D T.R.A.C.	HPV27

SYSTEM SYSTÈME	CODE	DESCRIPTION	MX Z 800 X/SPORT	MX Z 800 ADRENALINE/ RENEGADE	LEGEND 800 SE SDI	SUMMIT 800 HM X/HM	SUMMIT 800 X ADRENALINE	GRAND TOURING 800 SE SDI
			28	29	30	31	32	33
01	00	NO LABOR INVOLVED AUCUNE MAIN D'OEUVRE IMPLIQUÉE	0	0	0	0	0	0
01	01	REMOVE AND REPLACE ENGINE ASS'Y REPLACEMENT MOTEUR COMPLET	3.0	3.0	3.0	3.0	3.0	3.0
01	12	CYLINDER HEAD COVER AND/OR GASKET COUVERCLE DE CULASSE ET/OU JOINT	0.7	0.7	0.7	0.7	0.7	0.7
01	17	CYLINDERS AND/OR GASKETS (all) CYLINDRES ET/OU JOINTS (tous)	1.8	1.6	1.6	1.6	1.6	1.6
01	18	COOLANT TEMPERATURE SENDER CAPTEUR DE TEMPÉRATURE LIQUIDE	0.3	0.3	0.3	0.3	0.3	0.3
01	19	THERMOSTAT THERMOSTAT	0.3	0.3	0.3	0.3	0.3	0.3
01	20	WATER OUTLET SOCKET TUBULURE DE SORTIE DE LIQUIDE	0.7	0.7	0.7	0.7	0.7	0.7
01	22	RAVE ADJUSTING SCREW AND/OR COVER AND/OR SPRING (1) VIS DE RÉGLAGE RAVE ET/OU COUVERCLE ET/OU RESSORT (1)	0.3	0.3	0.3	0.3	0.3	0.3
01	23	RAVE VALVE EXHAUST AND/OR HOUSING (1) SOUPAPE D'ÉCHAPPEMENT RAVE ET/OU BÔITIER (1)	0.3	0.3	0.3	0.3	0.3	0.3
01	25	PISTON, PIN, CIRCLIP, RING (MAG) PISTON, AXE, FREIN D'AXE, SEGMENTS (MAG)	2.0	1.8	1.9	1.8	1.8	1.9
01	26	PISTON, PIN, CIRCLIP, RING (PTO) PISTON, AXE, FREIN D'AXE, SEGMENT (PDM)	2.0	1.8	1.9	1.8	1.8	1.9
01	27	PISTONS, PINS, CIRCLIPS, RINGS (MAG and PTO) PISTONS, AXES, FREINS, SEGMENTS (MAG et PDM)	2.2	2.0	2.2	2.0	2.0	2.2
01	38	WATER PUMP SHAFT (all parts) L'ARBRE DE LA POMPE À EAU (toutes pièces)	5.0	5.0	5.0	5.0	5.0	5.0
01	40	OIL LINE TUBE OR CHECK VALVE CONDUIT D'HUILE OU SOUPAPE DE RETENUE	0.8	0.8	0.8	0.8	0.8	0.8
01	41	WATER PUMP, IMPELLER, COVER AND/OR GASKET POMPE À EAU, CARTER DE POMPE, COUVERCLE ET/OU JOINT D'ÉTANCHÉITÉ	0.9	0.9	0.9	0.9	0.9	0.9
01	44	ENGINE RUBBER MOUNTS (3 or 4) TAMPONS D'ANCRAGE DE CAOUTCHOUC DU MOTEUR (3 ou 4)	2.2	1.1	1.1	1.1	1.1	1.1
01	45	ENGINE RUBBER MOUNTS SUPPORT (3 or 4) SUPPORTS DE TAMPONS D'ANCRAGE DE CAOUTCHOUC DU MOTEUR (3 ou 4)	2.3	1.2	1.2	1.2	1.2	1.2
01	47	ENGINE SUPPORT SUPPORT DE MOTEUR	2.1	2.1	2.1	2.1	2.1	2.1
01	48	CRANKCASE REPLACEMENT REPLACEMENT DU CARTER	5.2	5.2	5.2	5.2	5.2	5.2

SYSTEM SYSTÈME	CODE	DESCRIPTION	MX Z 800 X/SPORT	MX Z 800 ADRENALINE/ RENEGADE	LEGEND 800 SE SDI	SUMMIT 800 HM X/HM	SUMMIT 800 X ADRENALINE	GRAND TOURING 800 SE SDI
			28	29	30	31	32	33
01	49	CRANKCASE RESEAL AND/OR GASKET RECELLEMENT DU CARTER ET/OU JOINT	5.0	5.0	5.0	5.0	5.0	5.0
01	50	CRANKSHAFT AND/OR BEARINGS VILEBREQUIN ET/OU ROULEMENTS	4.8	4.8	4.8	4.8	4.8	4.8
01	71	EXHAUST MANIFOLD COLLECTEUR D'ÉCHAPPEMENT	0.3	0.3	0.3	0.3	0.3	0.3
01	72	TUNED PIPE TUYAU D'ÉCHAPPEMENT CALIBRÉ	0.3	0.3	0.3	0.3	0.3	0.3
01	75	MUFFLER AND/OR EXHAUST GROMMET/SUPPORT SILENCIEUX ET/OU BAGUE D'ÉCHAPPEMENT/SUPPORT	0.3	0.3	0.3	0.3	0.3	0.3
01	77	ENGINE RUBBER MOUNTS (1 or 2) TAMPONS D'ANCRAGE DU MOTEUR (1 ou 2)	1.0	1.0	1.0	1.0	1.0	1.0
01	79	COOLANT HOSE (tank to engine head) BOYAU DU SYSTÈME DE REFROIDISSEMENT (réserve au moteur)	0.3	0.3	0.3	0.3	0.3	0.3
01	80	REED VALVE ASS'Y AND/OR CARBURETOR SOCKET (1) SOUPAPE CLAPET COMPLÈTE ET/OU TUBULURE CARBURATEUR (1)	0.7	0.3	0.4	0.3	0.3	0.4
01	81	REED VALVE ASS'Y AND/OR CARBURETOR SOCKET (2) SOUPAPE CLAPET COMPLÈTE ET/OU TUBULURE CARBURATEUR (2)	0.8	0.4	0.5	0.4	0.4	0.5
01	84	TUNED PIPE SHIELD (1) COQUILLE TUYAU D'ÉCHAPPEMENT (1)	0.3	0.3	0.3	0.3	0.3	0.3
01	98	COOLANT RESERVOIR RÉSERVOIR D'ANTIGEL	0.5	0.7	0.7	0.7	0.7	0.7
01	99	CRANKSHAFT REBUILT VILEBREQUIN RÉUSINÉ	4.8	4.8	4.8	4.8	4.8	4.8
01	104	SHORT BLOCK KIT ENSEMBLE CARTER CYLINDRE	3.5	3.5	3.7	3.5	3.5	3.7
01	169	RAVE ADJUSTING SCREW AND/OR COVER AND/OR SPRING (2) VIS DE RÉGLAGE ET/OU COUVERCLE ET/OU RESSORT (2)	0.4	0.4	0.4	0.4	0.4	0.4
01	170	RAVE VALVE AND/OR HOUSING (2) SOUPAPE D'ÉCHAPPEMENT RAVE ET/OU BÔÎTIER (2)	0.4	0.4	0.4	0.4	0.4	0.4

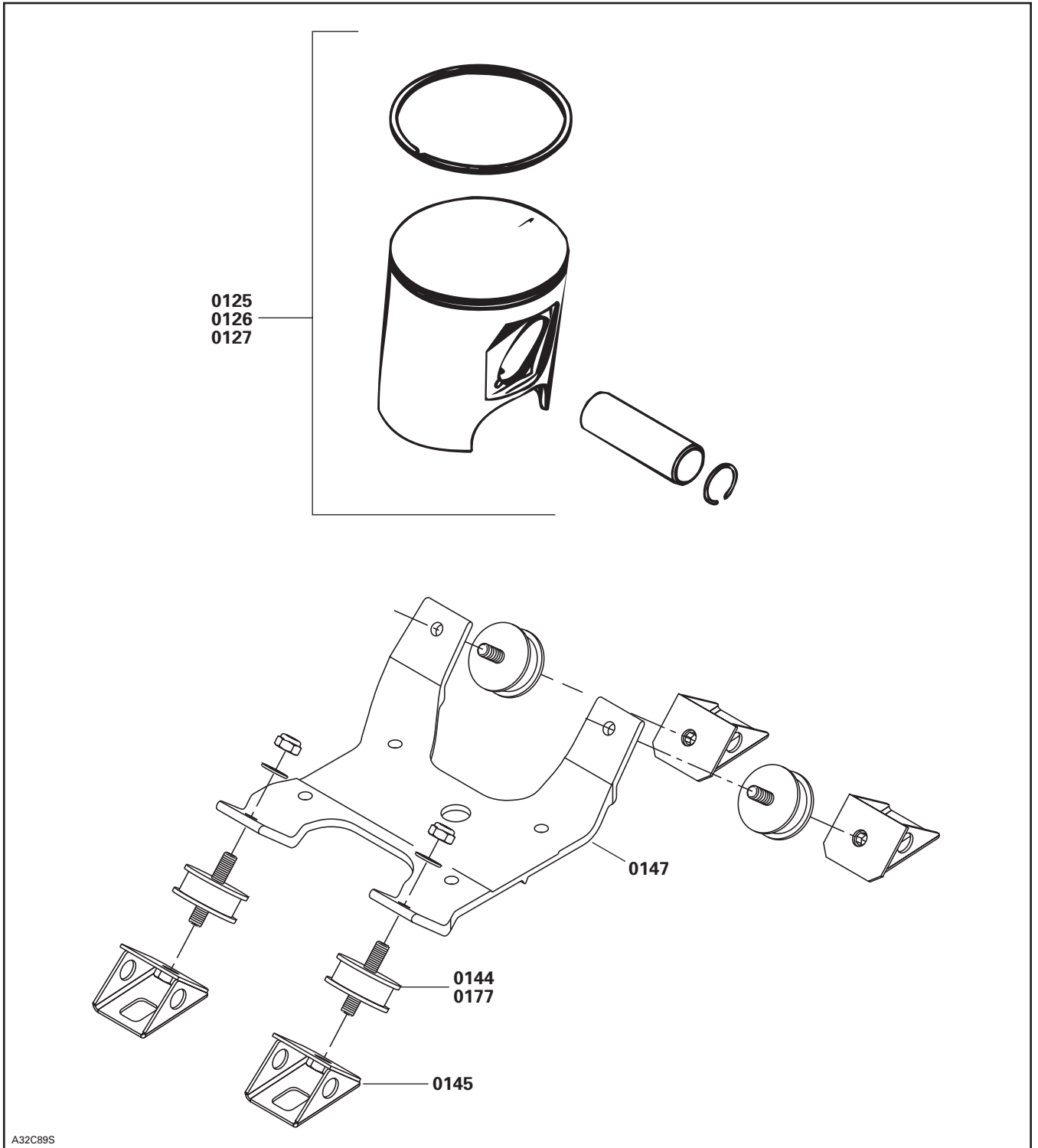

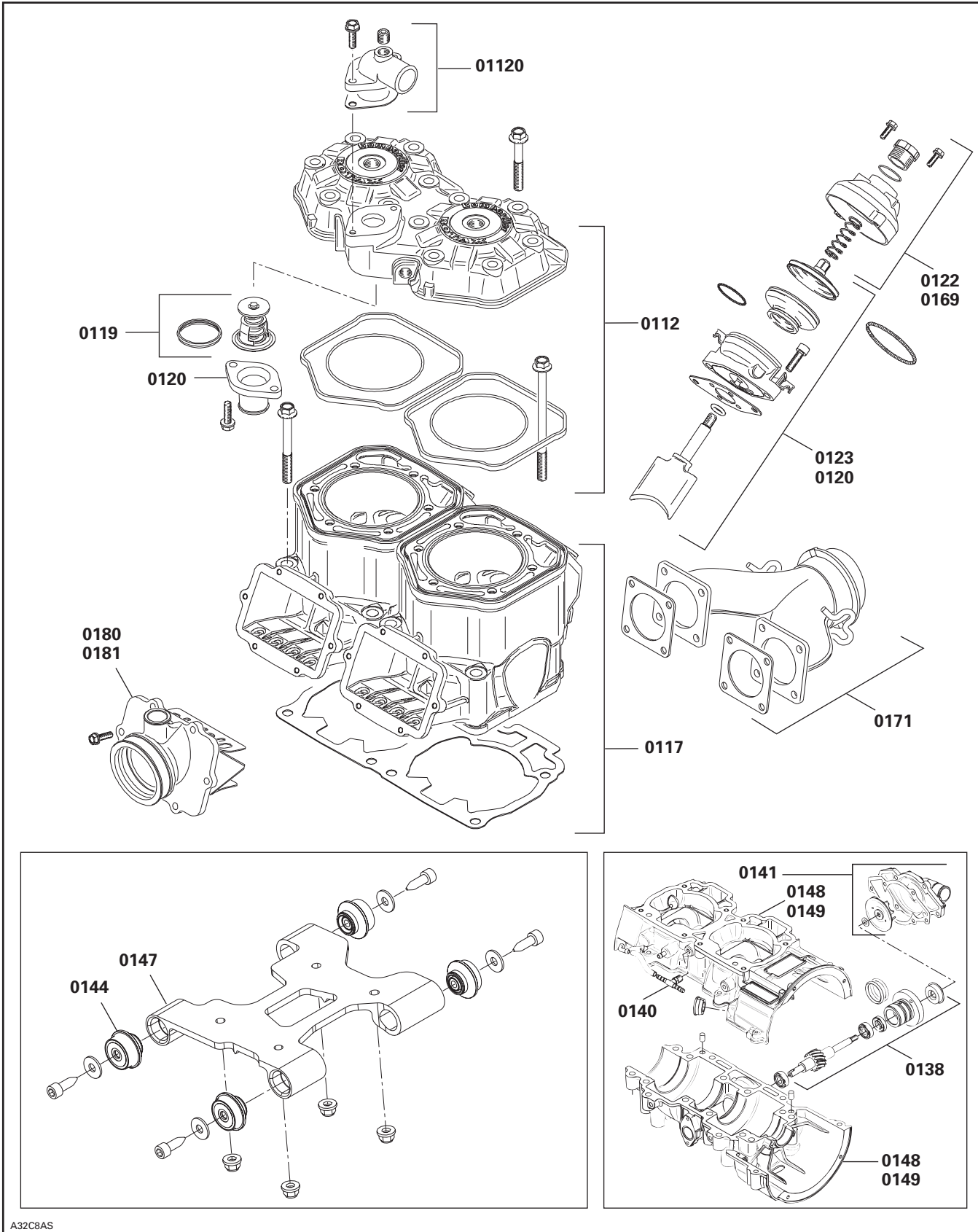

A32C8AS

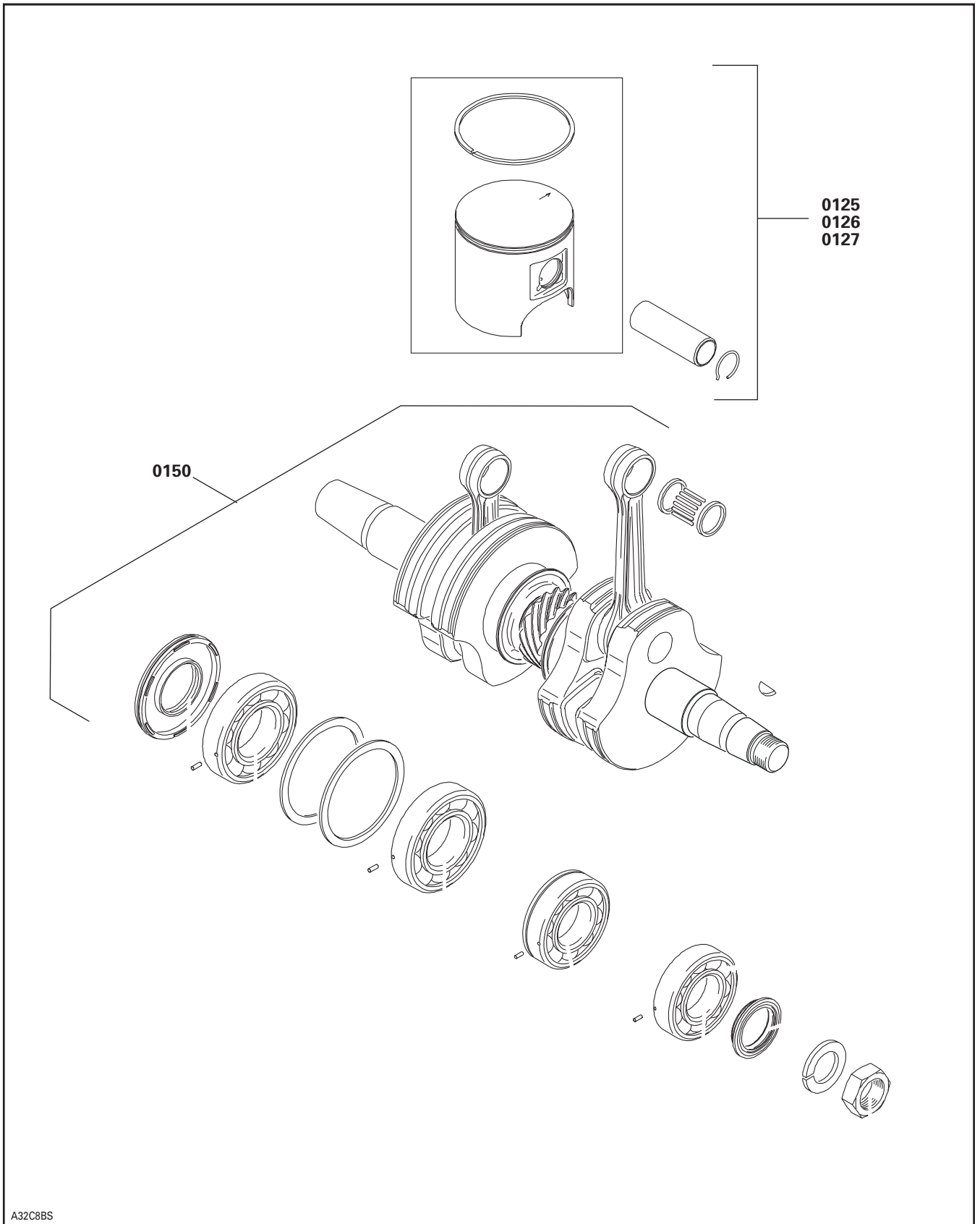

CARBURETOR AND OIL INJECTION SYSTEM CARBURATEUR ET SYSTÈME D'INJECTION D'HUILE

SYSTEM SYSTÈME	CODE	DESCRIPTION	MX Z 800 X/SPORT	MX Z 800 ADRENALINE/ RENEGADE	LEGEND 800 SE SDI	SUMMIT 800 HM X/HM	SUMMIT 800 X ADRENALINE	GRAND TOURING 800 SE SDI
			28	29	30	31	32	33

02	00	NO LABOR INVOLVED AUCUNE MAIN-D'OEUVRE IMPLIQUÉE	0	0	0	0	0	0
02	01	AIR INTAKE SILENCER ASS'Y (all parts) SILENCIEUX D'ADMISSION D'AIR COMPLET (toutes pièces)	0.3	0.3	0.3	0.3	0.3	0.3
02	03	CARBURETORS ASS'Y (2) CARBURATEURS COMPLET (2)	0.7	0.7		0.7	0.7	
02	04	RUBBER FLANGE (1) BRIDE DE CAOUTCHOUC (1)		0.3	0.3	0.3	0.3	0.3
02	06	THROTTLE CABLE CÂBLE D'ACCÉLÉRATEUR	0.3	0.3	0.3	0.3	0.3	0.3
02	08	OIL INJECTION PUMP POMPE À INJECTION D'HUILE	1.1	1.1	1.1	1.1	1.1	1.1
02	09	OIL INJECTION RESERVOIR RÉSERVOIR D'HUILE À INJECTION	0.5	0.5	0.5	0.5	0.5	0.5
02	10	FUEL PUMP POMPE À CARBURANT	0.6	0.4	0.6	0.4	0.4	0.6
02	11	FLOAT SYSTEM (all parts) (1 carburetor) SYSTÈME DE FLOTTEUR (toutes pièces) (1 carburateur)	0.6	0.6		0.6	0.6	
02	12	FLOAT SYSTEM (all parts) (2 carburetors) SYSTÈME DE FLOTTEUR (toutes pièces) (2 carburateurs)	0.7	0.7		0.7	0.7	
02	13	JET NEEDLE, THROTTLE SLIDE (1) AIGUILLE DE GICLEUR, TIROIR ACCÉLÉRATEUR (1)	0.6	0.6		0.6	0.6	
02	14	JET NEEDLES, THROTTLES SLIDES (2) AIGUILLES DE GICLEUR, TIROIRS ACCÉLÉRATEUR (2)	0.7	0.7		0.7	0.7	
**		CARBURETOR CLEANING AND REBUILDING (1) NETTOYAGE ET REMONTAGE DU CARBURATEUR (1)	0.7	0.7		0.7	0.7	
**		CARBURETORS CLEANING AND REBUILDING (2) NETTOYAGE ET REMONTAGE DES CARBURATEURS (2)	1.1	1.1		1.1	1.1	
02	17	MAIN JET, NEEDLE JET, PILOT JET (1) GICLEUR PRINCIPAL/AIGUILLE/RALENTI (1)	0.6	0.6		0.6	0.6	
02	18	MAIN JETS, NEEDLE JETS, PILOT JETS (2) GICLEURS PRINCIPAUX/AIGUILLE/RALENTI (2)	0.7	0.7		0.7	0.7	
02	24	OIL INJECTION FILTER FILTRE D'HUILE À INJECTION	0.4	0.3	0.3	0.3	0.3	0.3
02	25	OIL INJECTION LINE (1) BOYAU D'HUILE À INJECTION (1)	0.8	0.8	0.8	0.8	0.8	0.8
02	26	OIL INJECTION LINES (2) BOYAUX D'HUILE À INJECTION (2)	0.9	0.9	0.9	0.9	0.9	0.9

CARBURETOR AND OIL INJECTION SYSTEM CARBURATEUR ET SYSTÈME D'INJECTION D'HUILE

02

SYSTEM/SYSTEME

SYSTEM SYSTÈME	CODE	DESCRIPTION	MX Z 800 X/SPORT	MX Z 800 ADRENALINE/ RENEGADE	LEGEND 800 SE SDI	SUMMIT 800 HM X/HM	SUMMIT 800 X ADRENALINE	GRAND TOURING 800 SE SDI
			28	29	30	31	32	33
02	27	OIL LEVEL SENSOR CONTACTEUR DE NIVEAU D'HUILE	0.5	0.5	0.5	0.5	0.5	0.5
02	40	CHOKE CABLE CÂBLE D'ÉTRANGLEUR	0.3	0.3	0.3	0.3	0.3	0.3
02	43	PRESSURE MANIFOLD ASS'Y (D.P.M) COLLECTEUR DE PRESSION COMPLET (D.P.M)	0.4	0.4		0.4	0.4	
02	45	PRESSURE MANIFOLD HARNESS (D.P.M) CÂBLAGE COLLECTEUR DE PRESSION COMPLET (D.P.M)	0.3	0.3		0.3	0.3	
02	46	AIR TEMPERATURE SENSOR (air intake) CAPTEUR D'AIR DE TEMPÉRATURE (silencieux d'admission)	0.3	0.3	0.3	0.3	0.3	0.3
02	47	FUEL TANK RÉSERVOIR À ESSENCE	1.0	0.5	0.5	0.5	0.5	0.5
02	48	FUEL TANK CAP BOUCHON DU RÉSERVOIR À ESSENCE	0.3	0.3	0.3	0.3	0.3	0.3
02	49	FUEL TANK GROMMET RONDELLE ISOLANTE DU RÉSERVOIR À ESSENCE	0.3	0.5	0.5	0.5	0.5	0.5
02	50	THROTTLE HANDLE HOUSING LOGEMENT DE MANETTE D'ACCÉLÉRATEUR	0.4	0.4	0.4	0.4	0.4	0.4
02	51	HEATER THROTTLE LEVER MANETTE D'ACCÉLÉRATEUR CHAUFFANTE	0.3	0.3	0.3	0.3	0.3	0.3
02	52	FUEL FILTER FILTRE À CARBURANT	0.3	0.5	0.3	0.5	0.5	0.3
02	53	KILL SWITCH INTERRUPTEUR D'URGENCE	0.3	0.3	0.3	0.3	0.3	0.3
02	77	SOLENOID VALVE SOUPAPE SOLÉNOÏDE			0.3			0.3
02	78	HEATER PLATE (SOLENOID VALVE) PLAQUE CHAUFFANTE (SOUPAPE SOLÉNOÏDE)			0.3			0.3
02	79	FUEL RAIL RAMPE D'ESSENCE			0.3			0.3
02	80	INSPECTOR (1 OR 4) INSPECTEUR (1 OU 4)			0.4			0.4
02	81	THROTTLE BODY ASS'Y CARTER ACCÉLÉRATEUR COMPLET			0.5			0.5
02	82	THROTTLE SENSOR CAPTEUR POSITION ACCÉLÉRATEUR			0.4			0.4

CARBURETOR AND OIL INJECTION SYSTEM CARBURATEUR ET SYSTÈME D'INJECTION D'HUILE

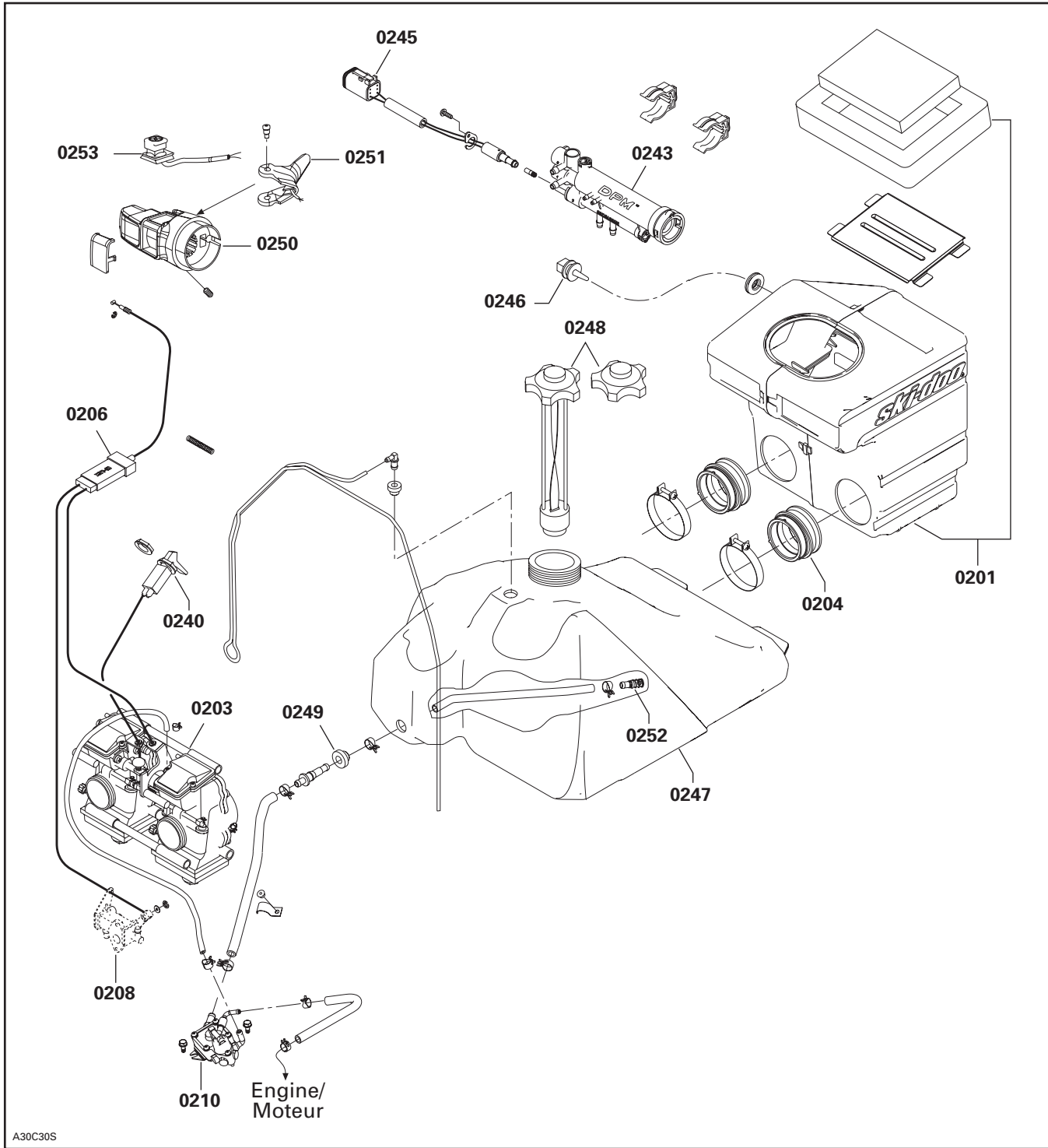

CARBURETOR AND OIL INJECTION SYSTEM CARBURATEUR ET SYSTÈME D'INJECTION D'HUILE

02
SYSTEM/SYSTEME

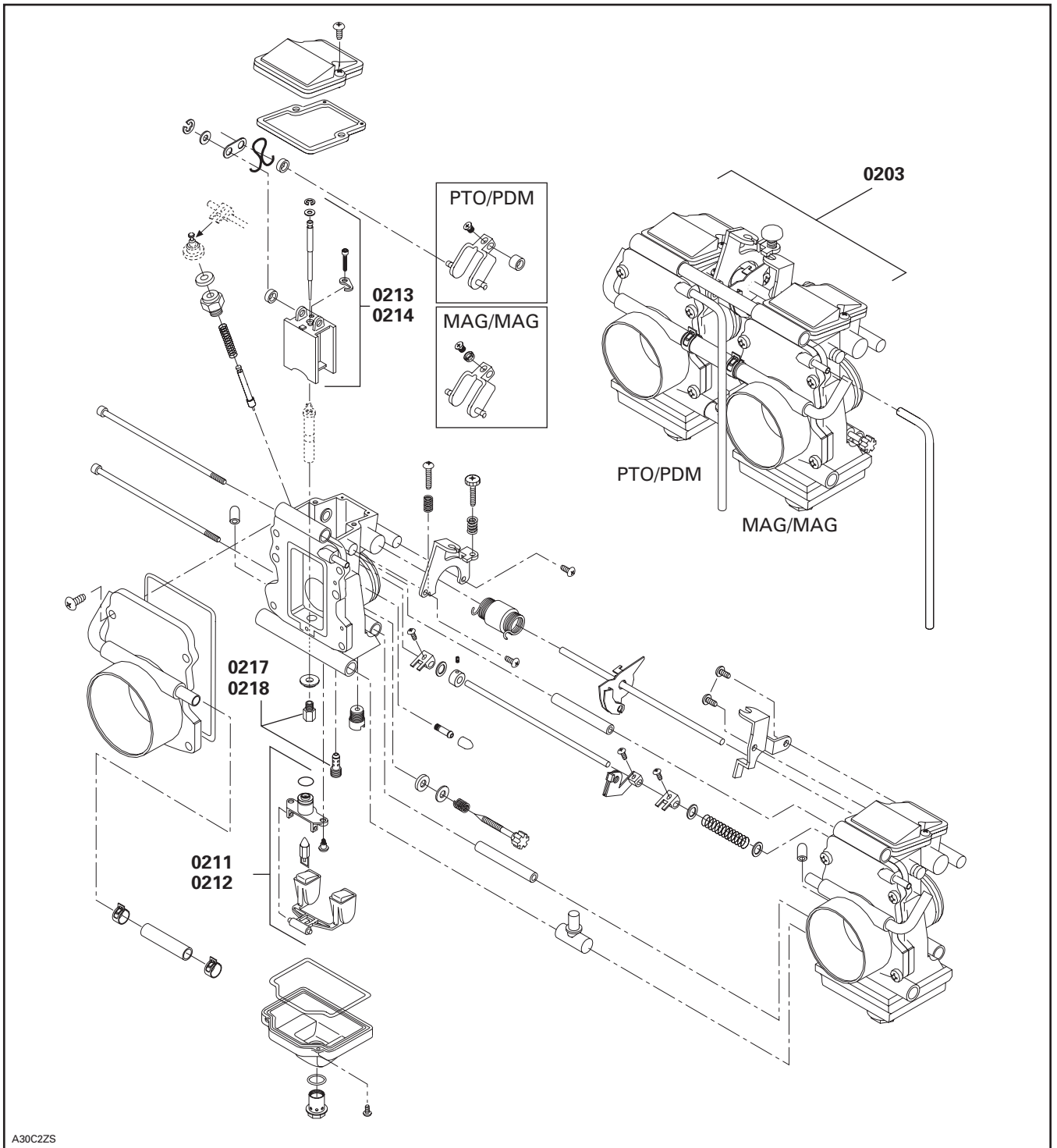

**CARBURETOR AND OIL INJECTION SYSTEM
CARBURATEUR ET SYSTÈME D'INJECTION D'HUILE**

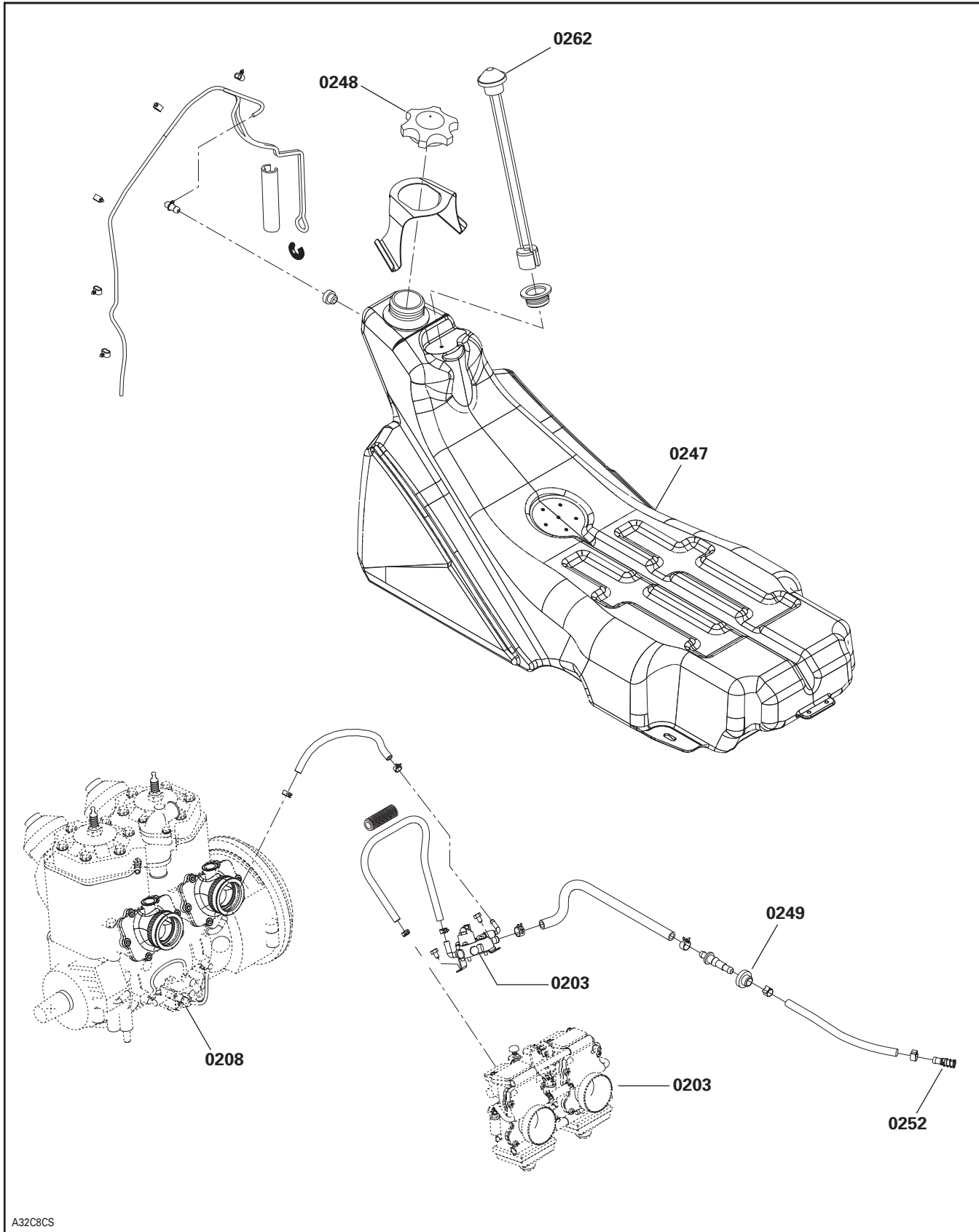

A32C8CS

CARBURETOR AND OIL INJECTION SYSTEM CARBURATEUR ET SYSTÈME D'INJECTION D'HUILE

02
SYSTEM/SYSTEME

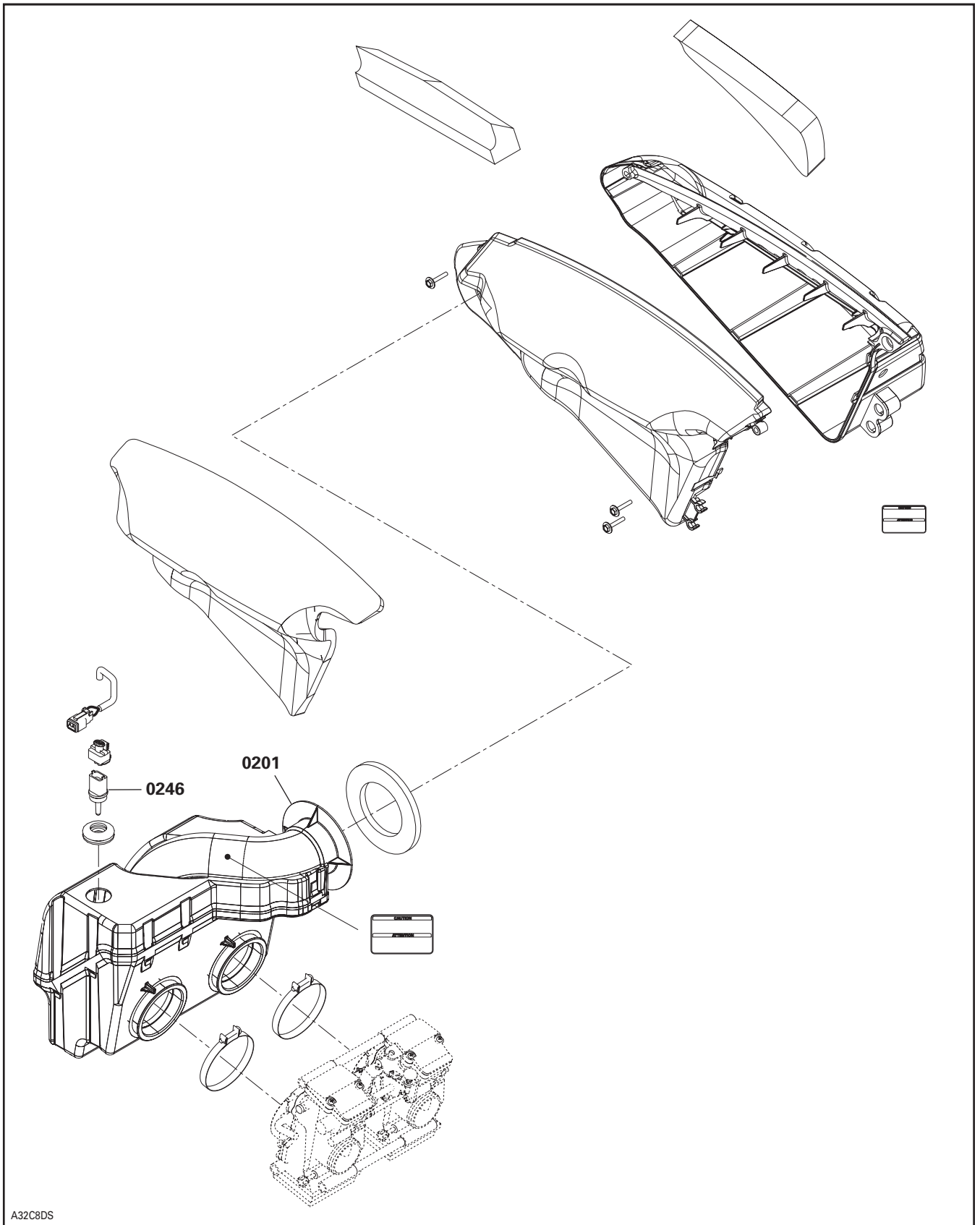

DPM

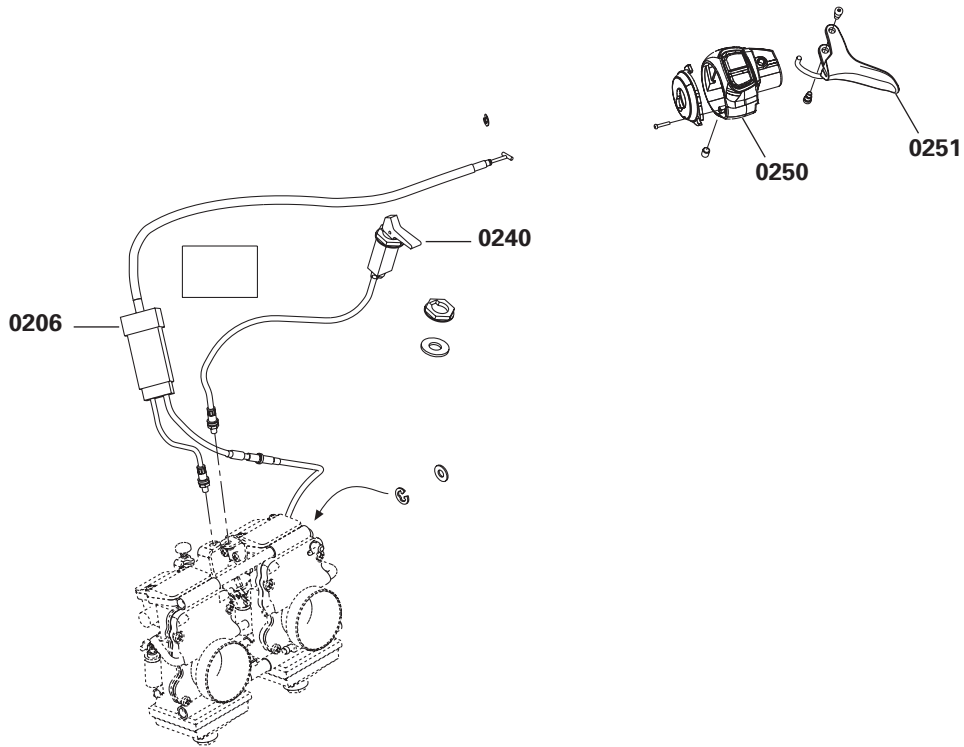
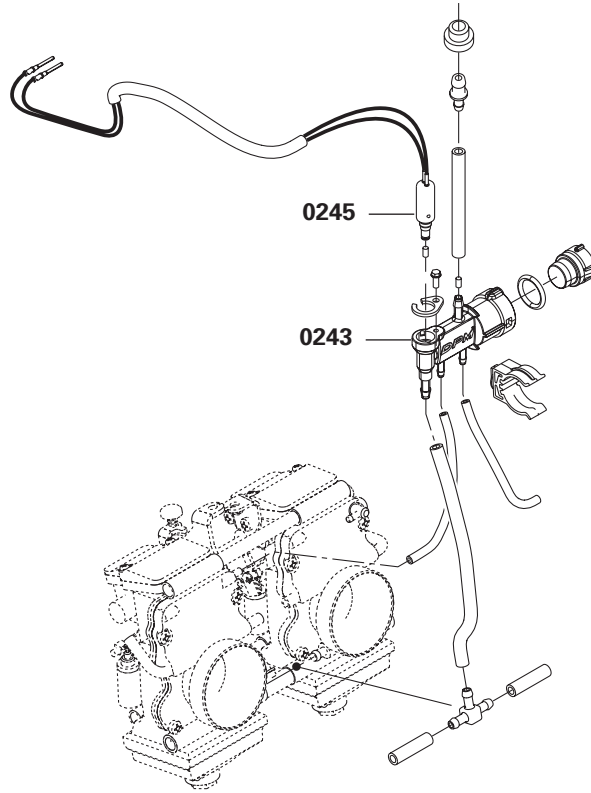

A32C8ES

CARBURETOR AND OIL INJECTION SYSTEM CARBURATEUR ET SYSTÈME D'INJECTION D'HUILE

02
SYSTEM/SYSTEME

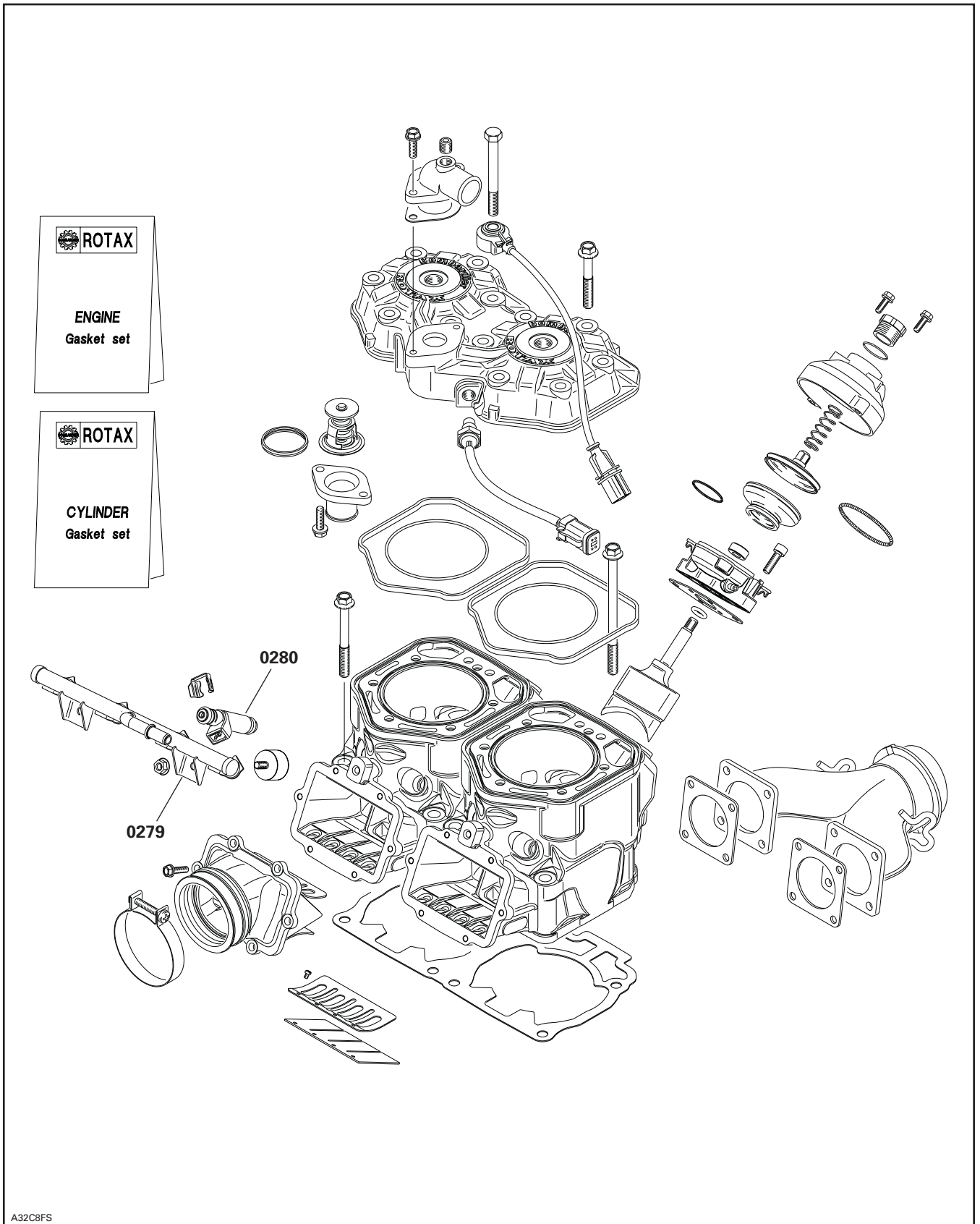

A32C8FS

SYSTEM SYSTÈME	CODE	DESCRIPTION	MX Z 800 X/SPORT	MX Z 800 ADRENALINE/ RENEGADE	LEGEND 800 SE SDI	SUMMIT 800 HM X/HM	SUMMIT 800 X ADRENALINE	GRAND TOURING 800 SE SDI
			28	29	30	31	32	33
03	00	NO LABOR INVOLVED AUCUNE MAIN-D'OEUVRE IMPLIQUÉE	0	0	0	0	0	0
03	01	FLYWHEEL VOLANT MOTEUR	0.4	0.3	0.3	0.3	0.3	0.3
03	02	MAGNETO ASS'Y MAGNÉTO COMPLET	0.6	0.6	0.6	0.6	0.6	0.6
03	08	IGNITION COIL BOBINE D'ALLUMAGE	0.3	0.3	0.3	0.3	0.3	0.3
03	10	IGNITION CABLE CÂBLE D'ALLUMAGE	0.3	0.3	0.3	0.3	0.3	0.3
**		TIMING RÉGLAGE DE L'ALLUMAGE	0.3	0.3	0.3	0.3	0.3	0.3
03	13	TRIGGER COIL (1) BOBINE DE DÉCLENCHEMENT (1)	0.6	0.6	0.6	0.6	0.6	0.6
03	15	SPARK PLUG PROTECTOR PROTECTEUR DE BOUGIES	0.3	0.3	0.3	0.3	0.3	0.3

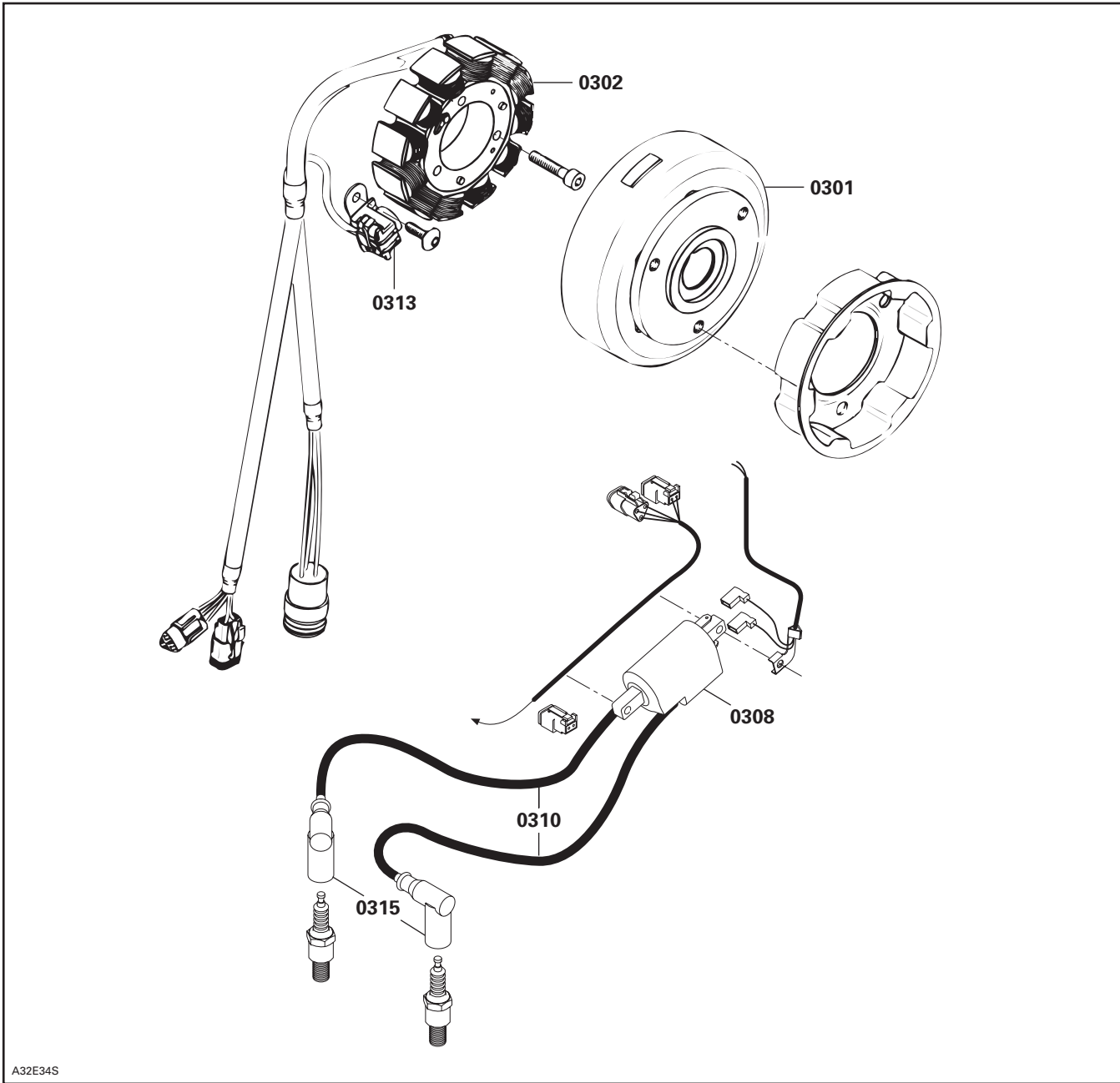

A32E34S

SYSTEM SYSTÈME	CODE	DESCRIPTION	MX Z 800 X/SPORT	MX Z 800 ADRENALINE/ RENEGADE	LEGEND 800 SE SDI	SUMMIT 800 HM X/HM	SUMMIT 800 X ADRENALINE	GRAND TOURING 800 SE SDI
			28	29	30	31	32	33

04	00	NO LABOR INVOLVED AUCUNE MAIN-D'OEUVRE IMPLIQUÉE	0	0	0	0	0	0
04	01	REWIND STARTER (all parts) EXCEPT HANDLE DÉMARREUR À RAPPEL (toutes pièces) SAUF POIGNÉE	0.3	0.3	0.3	0.3	0.3	0.3
04	02	ELECTRIC STARTER ASS'Y DÉMARREUR ÉLECTRIQUE COMPLET	0.4	0.4	0.4			0.4
04	03	STARTER RELAY SOLÉNOÏDE DE DÉMARRAGE	0.3	0.4	0.4			0.4
04	09	REWIND STARTER HANDLE POIGNÉE DU DÉMARREUR À RAPPEL	0.3	0.3	0.3	0.3	0.3	0.3
04	24	ELECTRIC STARTER (one or all parts) DÉMARREUR ÉLECTRIQUE (une ou toutes les pièces)	0.6	0.6	0.6			0.6

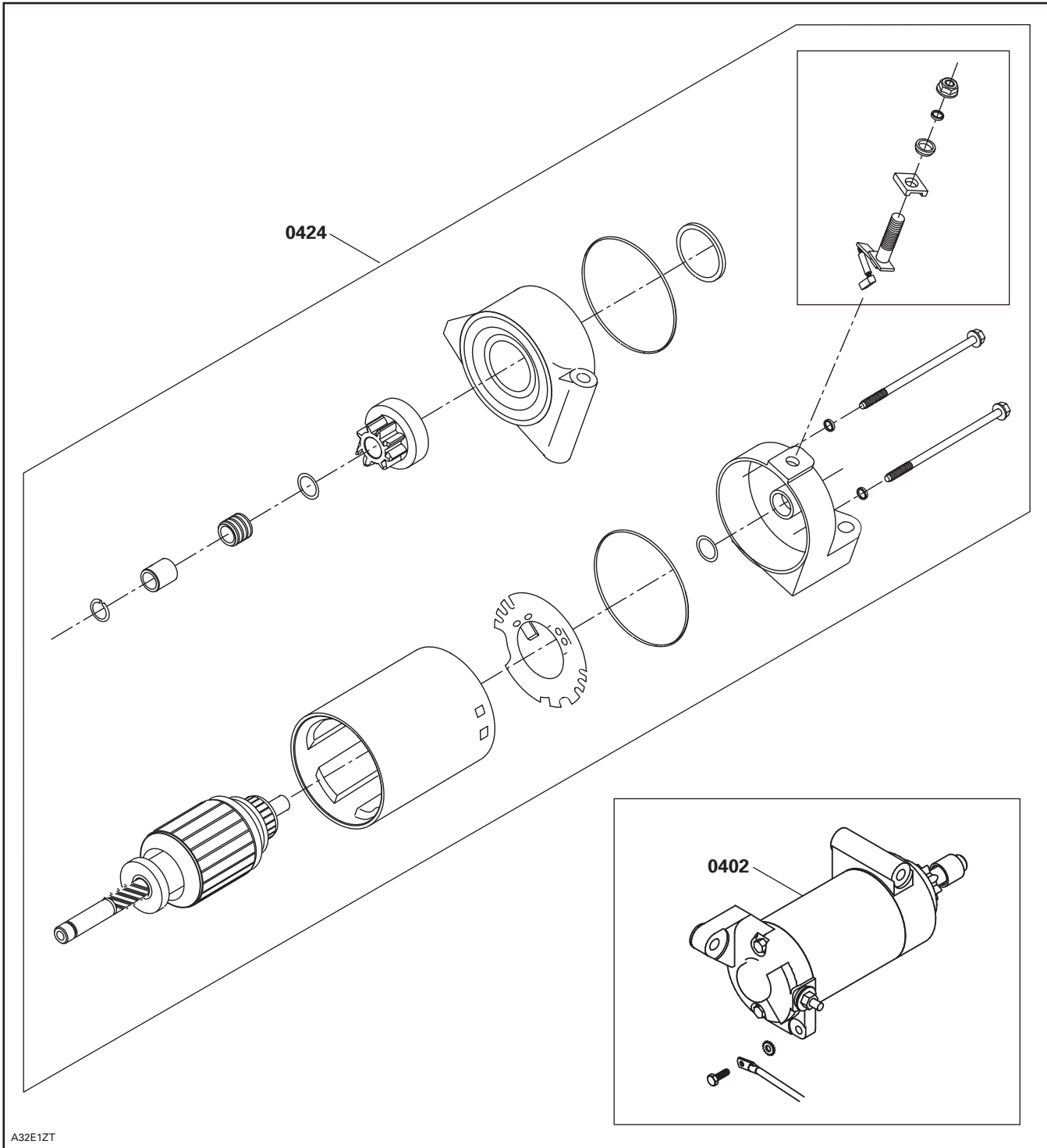

A32E1ZT

TRANSMISSION SYSTEM SYSTÈME DE TRANSMISSION

05

SYSTEM/SYSTEME

SYSTEM SYSTÈME	CODE	DESCRIPTION	MX Z 800 X/SPORT	MX Z 800 ADRENALINE/ RENEGADE	LEGEND 800 SE SDI	SUMMIT 800 HM X/HM	SUMMIT 800 X ADRENALINE	GRAND TOURING 800 SE SDI
			28	29	30	31	32	33
05	00	NO LABOR INVOLVED AUCUNE MAIN-D'OEUVRE IMPLIQUÉE	0	0	0	0	0	0
05	01	DRIVE PULLEY ASS'Y OR SLIDING FLANGE POULIE MOTRICE COMPLÈTE OU FLASQUE COULISSANTE	0.3	0.3	0.3	0.3	0.3	0.3
05	06	TRA GOVERNOR CUP AND/OR FIXED HALF CUVETTE DE RÉGULATEUR ET/OU PARTIE FIXE TRA	0.3	0.3	0.3	0.3	0.3	0.3
05	07	TRA RAMPS AND/OR ADJUSTMENT SCREW RAMPES TRA ET/OU VIS DE RÉGLAGE DE POULIE	0.3	0.3	0.3	0.3	0.3	0.3
05	08	TRA SPRING COVER AND/OR SPRING AND/OR BUSHING COUVERCLE DU RESSORT ET/OU RESSORT ET/OU DOUILLE TRA	0.7	0.7	0.7	0.7	0.7	0.7
05	09	TRA SLIDER SHOES AND/OR SPRINGS GLISSIÈRE ET/OU RESSORTS TRA	0.3	0.3	0.3	0.3	0.3	0.3
05	10	TRA SLIDING HALF, BUSHING AND/OR LEVER ASS'Y DEMI-POULIE COULISSANTE, DOUILLE ET/OU LEVIER COMPLET TRA	0.5	0.5	0.5	0.5	0.5	0.5
05	11	DRIVEN PULLEY FIXED HALF DEMI-POULIE MENÉE FIXE	0.3	0.3	0.3	0.3	0.3	0.3
05	12	DRIVEN PULLEY SLIDING HALF DEMI-POULIE MENÉE COULISSANTE	0.3	0.3	0.3	0.3	0.3	0.3
05	13	DRIVEN PULLEY CAM AND/OR SPRING CAME ET/OU RESSORT DE POULIE MENÉE	0.3	0.3	0.3	0.3	0.3	0.3
05	14	DRIVEN PULLEY SMALL BUSHING PETITE DOUILLE DE POULIE MENÉE	0.6	0.6	0.6	0.6	0.6	0.6
05	15	DRIVEN PULLEY LARGE BUSHING GROSSE DOUILLE DE POULIE MENÉE	0.6	0.6	0.6	0.6	0.6	0.6
05	17	COUNTERSHAFT BALL BEARING AND/OR FLANGE ROULEMENT À BILLE DE L'ARBRE DE RENVOI ET/OU FLASQUE	0.4	0.4	0.4	0.4	0.4	0.4
05	18	COUNTERSHAFT ARBRE DE RENVOI	1.0	1.0	1.0	1.0	1.0	1.0
05	19	DRIVE BELT AND/OR BELT GUARD COURROIE D'ENTRAÎNEMENT ET/OU GARDE-COURROIE	0.3	0.3	0.3	0.3	0.3	0.3
05	20	CHAINCASE SEAL AND/OR BEARING ANNEAU D'ÉTANCHÉITÉ DE CARTER ET/OU ROULEMENT	1.4	1.4	1.4	1.4	1.4	1.4
05	21	CHAINCASE CARTER DE CHAÎNE	1.8	1.8	2.0	1.8	1.8	2.0
05	22	CHAINCASE COVER COUVERCLE DE CARTER DE CHAÎNE	0.4	0.4	0.4	0.4	0.4	0.4
05	23	CHAINCASE UPPER SPROCKET AND/OR CENTRAL SPROCKET PIGNON SUPÉRIEUR DE CARTER ET/OU PIGNON CENTRAL	0.5	0.5	0.6	0.5	0.5	0.6
05	24	CHAINCASE LOWER SPROCKET PIGNON INFÉRIEUR DE CARTER DE CHAÎNE	0.5	0.5	0.6	0.5	0.5	0.6
05	25	CHAINCASE DRIVE CHAIN CHAÎNE D'ENTRAÎNEMENT DE CARTER DE CHAÎNE	0.4	0.4	0.6	0.4	0.4	0.6
05	26	CHAINCASE TENSIONERS TENDEURS DE CARTER DE CHAÎNE	0.3	0.3	0.6	0.3	0.3	0.6

SYSTEM SYSTÈME	CODE	DESCRIPTION	MX Z 800 X/SPORT	MX Z 800 ADRENALINE/ RENEGADE	LEGEND 800 SE SDI	SUMMIT 800 HM X/HM	SUMMIT 800 X ADRENALINE	GRAND TOURING 800 SE SDI
			28	29	30	31	32	33
05	27	TENSIONER ADJUSTING SCREW VIS DE RÉGLAGE DE TENDEUR	0.3	1.8	2.0	1.8	1.8	2.0
05	44	RING GEAR COURONNE DE DÉMARRAGE	0.4	0.4	0.4	0.4	0.4	0.4

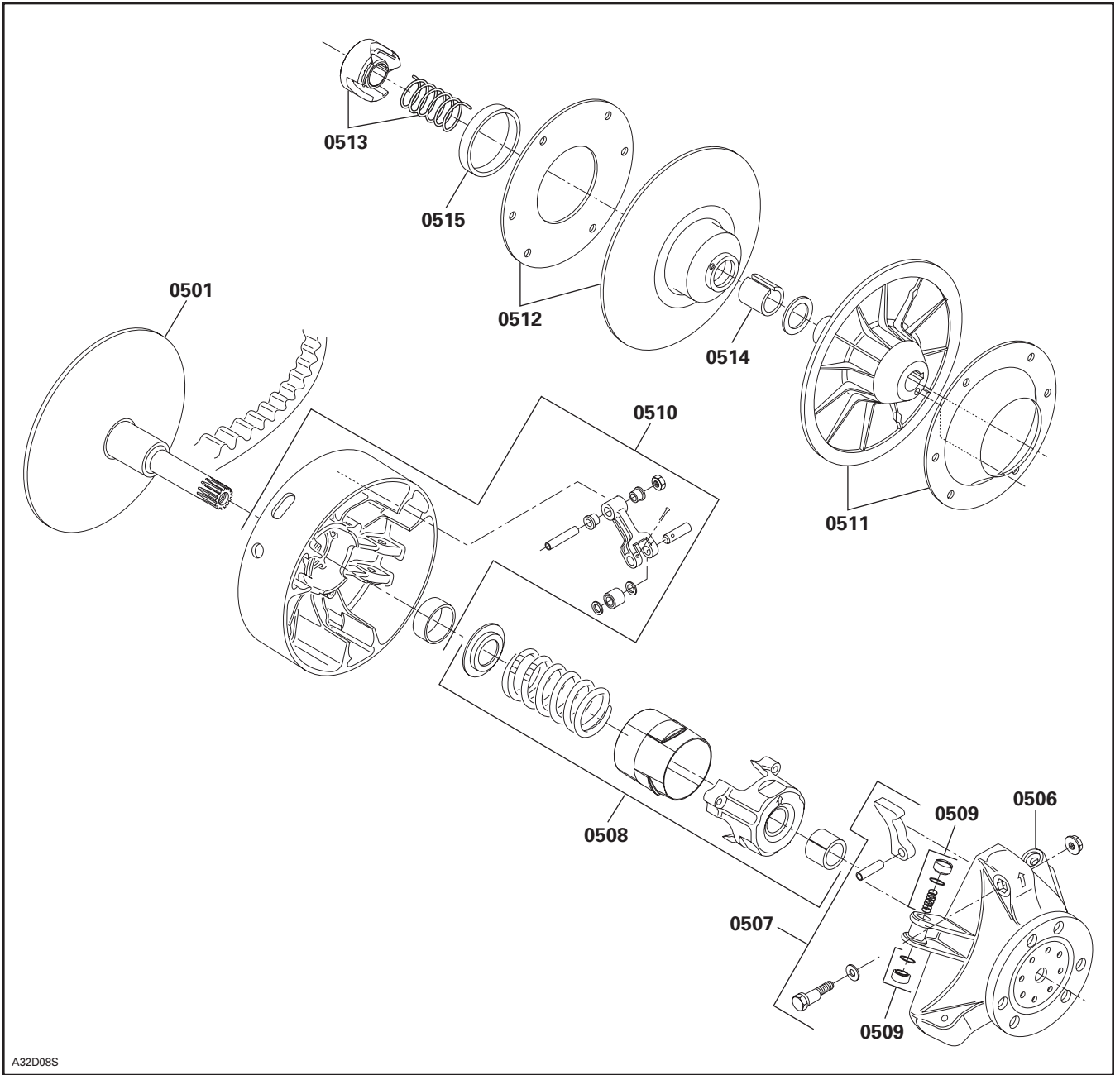

A32D08S

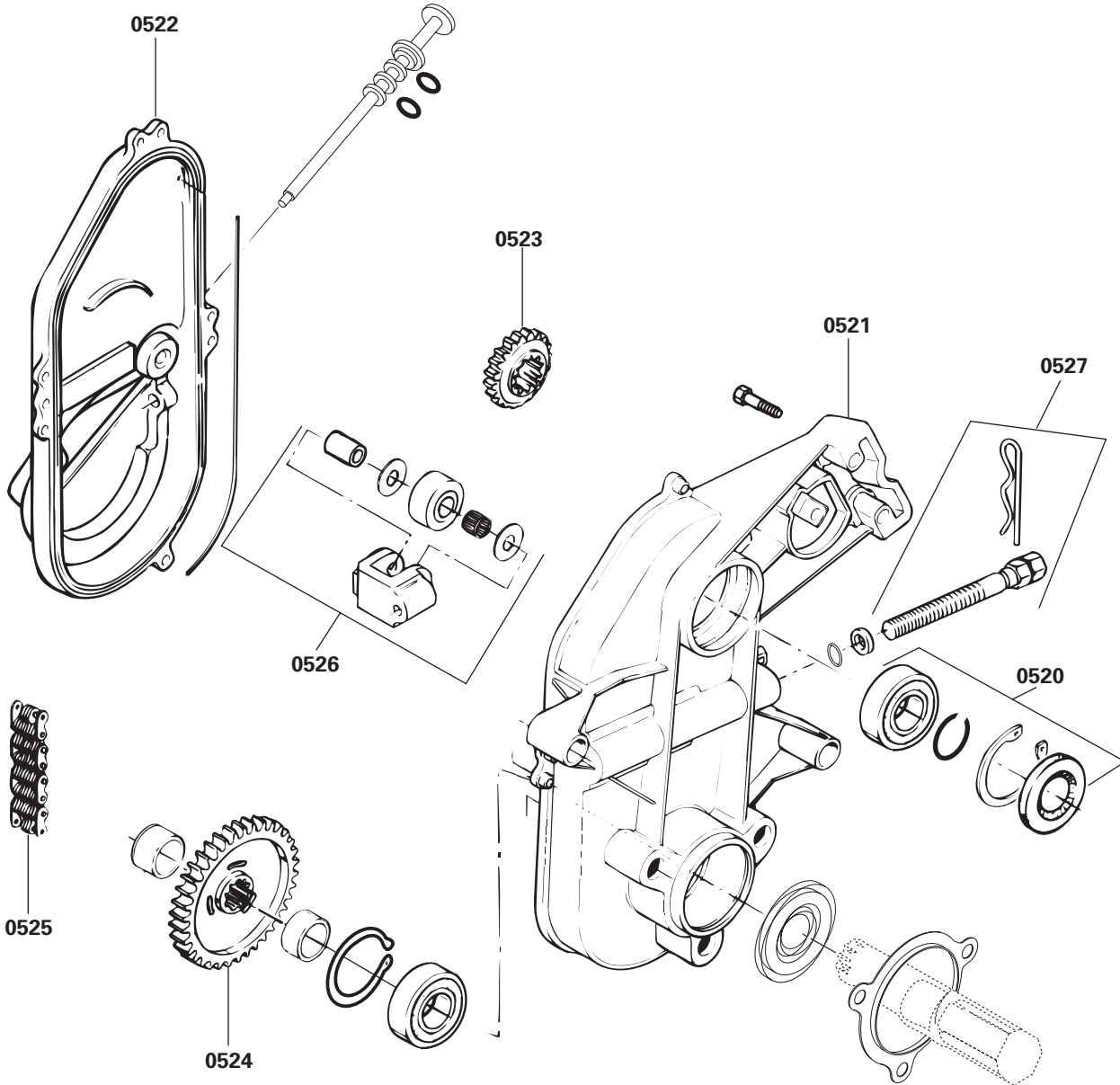

A06D26T

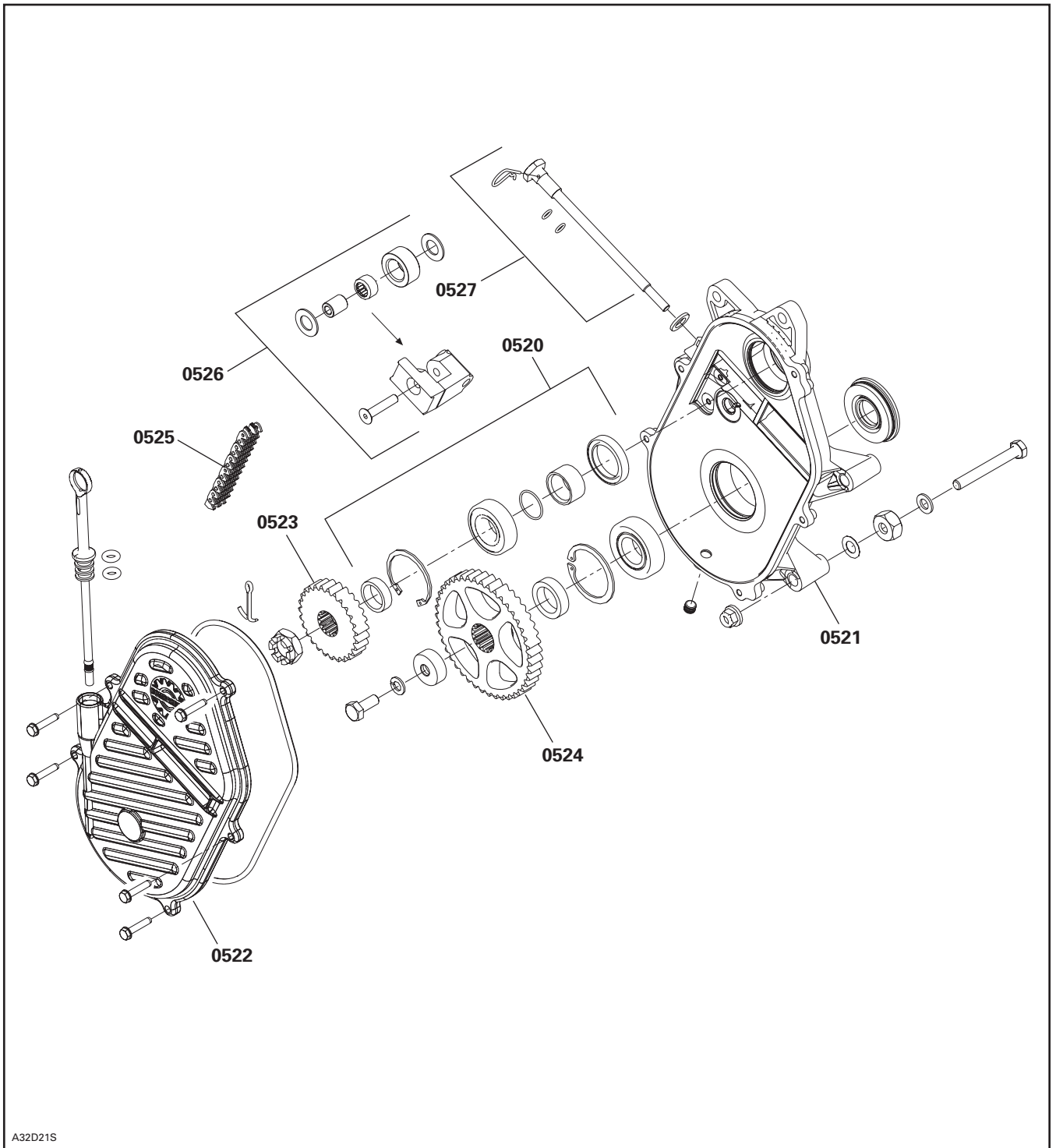

A32D21S

SYSTEM SYSTÈME	CODE	DESCRIPTION	MX Z 800 X/SPORT	MX Z 800 ADRENALINE/ RENEGADE	LEGEND 800 SE SDI	SUMMIT 800 HM X/HM	SUMMIT 800 X ADRENALINE	GRAND TOURING 800 SE SDI
			28	29	30	31	32	33

06	00	NO LABOR INVOLVED AUCUNE MAIN-D'OEUVRE IMPLIQUÉE	0	0	0	0	0	0
06	01	BRAKE OIL HOSE BOYAU À L'HUILE POUR FREIN	0.6	0.7	0.7	0.7	0.7	0.7
06	02	BRACKET, CALIPER, BRAKE PAD, RELEASE SPRING SUPPORT, ÉTRIER, PLAQUETTE, CLIQUET, LEVIER	0.4	0.8	0.8	0.8	0.8	0.8
06	03	DISC DISQUE	1.2	1.2	1.2	1.2	1.2	1.2
06	05	BRAKE PADS PLAQUETTES DE FREIN	0.3	0.3	0.3	0.3	0.3	0.3
06	06	MASTER CYLINDER MAÎTRE CYLINDRE	0.4	0.7	0.7	0.7	0.7	0.7
06	07	BRAKE LEVER ASS'Y LEVIER DE FREIN COMPLET	0.3	0.3	0.3	0.3	0.3	0.3
06	08	MICROSWITCH BRAKE ASS'Y INTERRUPTEUR MICRO-CONTACT DE FREIN COMPLET	0.3	0.3	0.3	0.3	0.3	0.3

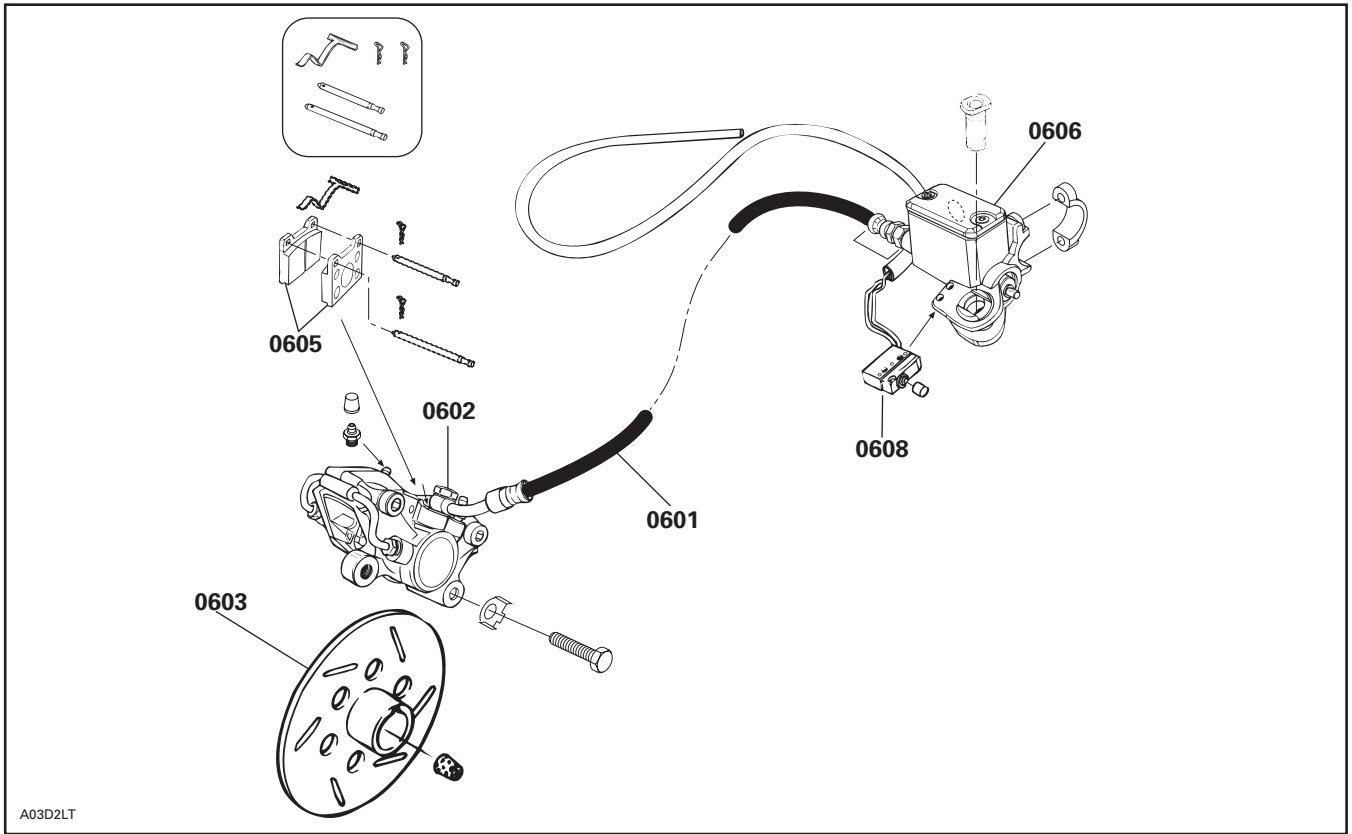

A03D2LT

STEERING SYSTEM AND FRONT SUSPENSION SYSTÈME DE DIRECTION ET SUSPENSION AVANT

SYSTEM SYSTÈME	CODE	DESCRIPTION	MX Z 800 X/SPORT	MX Z 800 ADRENALINE/ RENEGADE	LEGEND 800 SE SDI	SUMMIT 800 HM X/HM	SUMMIT 800 X ADRENALINE	GRAND TOURING 800 SE SDI
			28	29	30	31	32	33

07	00	NO LABOR INVOLVED AUCUNE MAIN-D'OEUVRE IMPLIQUÉE	0	0	0	0	0	0
07	01	SKI (1) SKI (1)	0.3	0.3	0.3	0.3	0.3	0.3
07	02	SKIS (2) SKIS (2)	0.4	0.4	0.4	0.4	0.4	0.4
07	03	SKI RUNNER LISSES	0.3	0.3	0.3	0.3	0.3	0.3
07	08	SKI LEG (RH) AND/OR BUSHING JAMBE DE SKI (D) ET/OU DOUILLE	0.5	0.3	0.3	0.3	0.3	0.3
07	09	SKI LEG (LH) AND/OR BUSHING JAMBE DE SKI (G) ET/OU DOUILLE	0.5	0.3	0.3	0.3	0.3	0.3
07	10	STEERING ARM (RH) BRAS DE DIRECTION (D)		0.3	0.3	0.3	0.3	0.3
07	11	STEERING ARM (LH) BRAS DE DIRECTION (G)		0.3	0.3	0.3	0.3	0.3
07	12	STEERING ARM BALL JOINT (RH) JOINT À ROTULE DE BRAS DE DIRECTION (D)		0.3	0.3	0.3	0.3	0.3
07	13	STEERING ARM BALL JOINT (LH) JOINT À ROTULE DE BRAS DE DIRECTION (G)	0.3	0.3	0.3	0.3	0.3	0.3
07	18	TIE ROD (main tube/steering arm) BARRE D'ACCOUPLLEMENT (colonne/bras direction)	0.6	2.0	2.0	2.0	2.0	2.0
07	19	TIE ROD (RH and LH main tube/steering arm) BARRE D'ACCOUPLLEMENT (colonne/bras direction D et G)	0.5	1.0	1.0	1.0	1.0	1.0
07	20	TIE ROD COVER (1) CAPUCHON DE TIMONERIE (1)	0.7	0.4	0.4	0.4	0.4	0.4
07	21	TIE ROD COVERS (2) CAPUCHONS DE TIMONERIE (2)	1.3	0.8	0.8	0.8	0.8	0.8
07	22	STEERING PIVOT ARM BRAS DE DIRECTION PIVOTANT	0.5	0.5	0.5	0.5	0.5	0.5
07	23	STEERING MAIN TUBE BALL JOINT JOINT À ROTULE DE COLONNE DE DIRECTION	0.6	2.0	2.0	2.0	2.0	2.0
07	24	STEERING MAIN TUBE COLONNE DE DIRECTION	1.1	2.1	2.1	2.1	2.1	2.1
07	25	HANDLE BAR GUIDON	0.4	0.4	0.4	0.4	0.4	0.4
07	27	HANDLE BAR PADDING COUSSINET DE GUIDON	0.3	0.3	0.3	0.3	0.3	0.3

STEERING SYSTEM AND FRONT SUSPENSION SYSTÈME DE DIRECTION ET SUSPENSION AVANT

07

SYSTEM/SYSTÈME

SYSTEM SYSTÈME	CODE	DESCRIPTION	MX Z 800 X/SPORT	MX Z 800 ADRENALINE/ RENEGADE	LEGEND 800 SE SDI	SUMMIT 800 HM X/HM	SUMMIT 800 X ADRENALINE	GRAND TOURING 800 SE SDI
			28	29	30	31	32	33
07	28	UPPER STEERING MAIN TUBE BUSHING DOUILLE SUPÉRIEURE DE COLONNE DE DIRECTION	0.5	0.7	0.7	0.7	0.7	0.7
07	29	LOWER STEERING MAIN TUBE BUSHING DOUILLE INFÉRIEURE DE COLONNE DE DIRECTION	0.3	2.1	2.1	2.1	2.1	2.1
07	31	SWING ARM (LH or RH) BRAS OSCILLANT (G ou D)		0.4	0.4	0.4	0.4	0.4
07	32	LOWER ARM (LH or RH) BRAS DE SUSPENSION INFÉRIEUR (G ou D)	0.6	0.5	0.5	0.5	0.5	0.5
07	33	UPPER ARM (LH or RH) BRAS DE SUSPENSION SUPÉRIEUR (G ou D)	0.5	0.3	0.3	0.3	0.3	0.3
07	35	HANDLE STEERING SUPPORT (all) SUPPORT DE GUIDON (tous)	0.3	0.3	0.3	0.3	0.3	0.3
07	36	HEATED GRIPS POIGNÉES CHAUFFANTES	0.4	0.4	0.4	0.4	0.4	0.4
07	37	SHOCK AND/OR SPRING (1) AMORTISSEUR ET/OU RESSORT (1)	0.3	0.3	0.3	0.3	0.3	0.3
07	38	SHOCKS AND/OR SPRINGS (2) AMORTISSEURS ET/OU RESSORTS (2)	0.4	0.4	0.4	0.4	0.4	0.4
07	39	STABILIZER BAR BARRE STABILISATRICE	0.9	0.4	0.4	0.4	0.4	0.4
07	49	STABILIZER BAR BUSHING PLAQUETTE BARRE STABILISATRICE	0.3	0.3	0.3	0.3	0.3	0.3
07	55	FRONT SWING ARM DECAL (1 or 2) DÉCALQUE BRAS SUSPENSION AVANT (1 ou 2)	0.3	0.3	0.3	0.3	0.3	0.3
07	59	TIE ROD (steering shaft LH) BARRE D'ACCOUPLMENT (arbre de direction G)	0.3	0.3	0.3	0.3	0.3	0.3
07	60	TIE ROD (steering shaft, steering arm RH) BARRE D'ACCOUPLMENT (arbre de direction, bras de direction D)	0.3	0.3	0.3	0.3	0.3	0.3

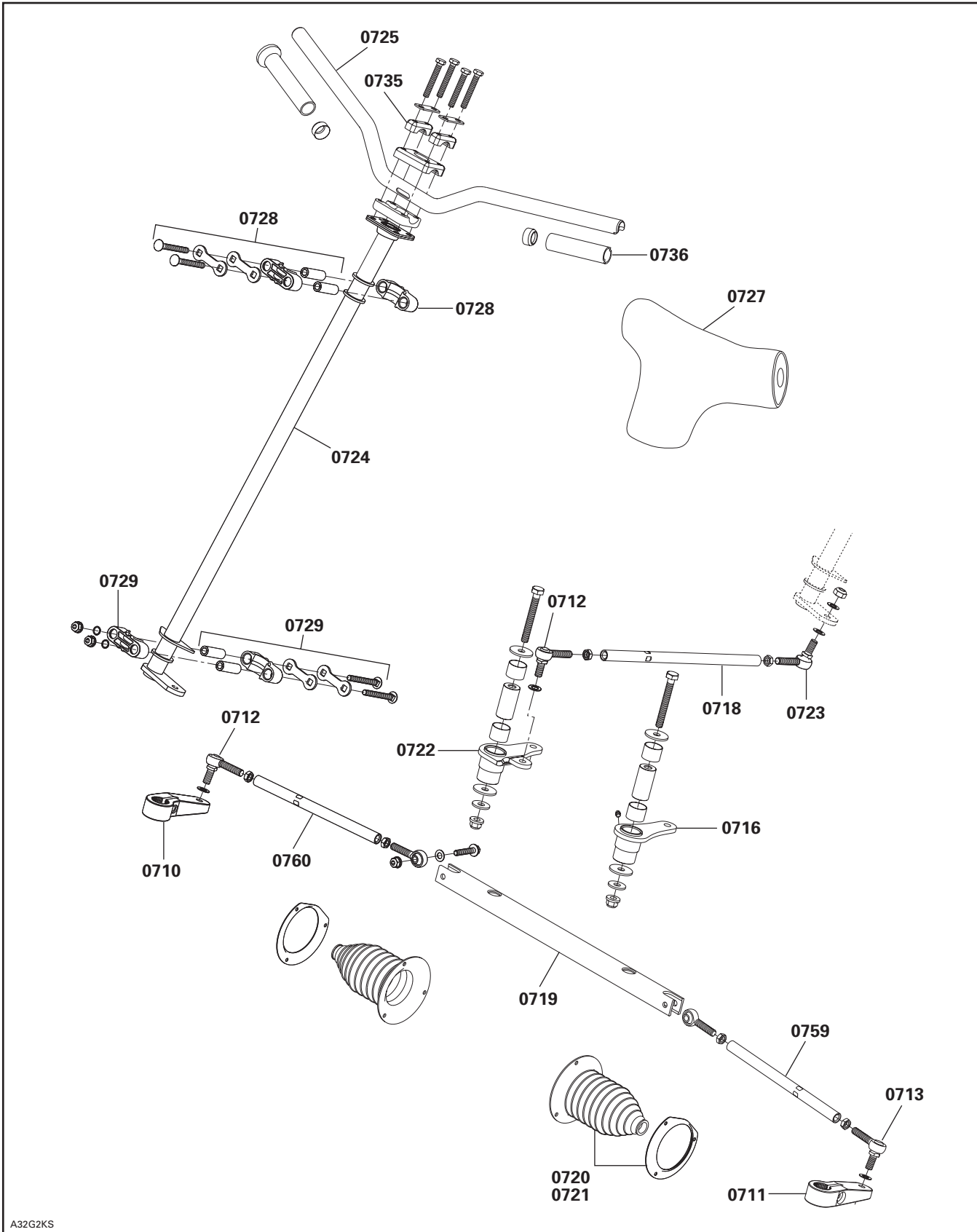

A32G2KS

STEERING SYSTEM AND FRONT SUSPENSION SYSTÈME DE DIRECTION ET SUSPENSION AVANT

07
SYSTEM/SYSTEME

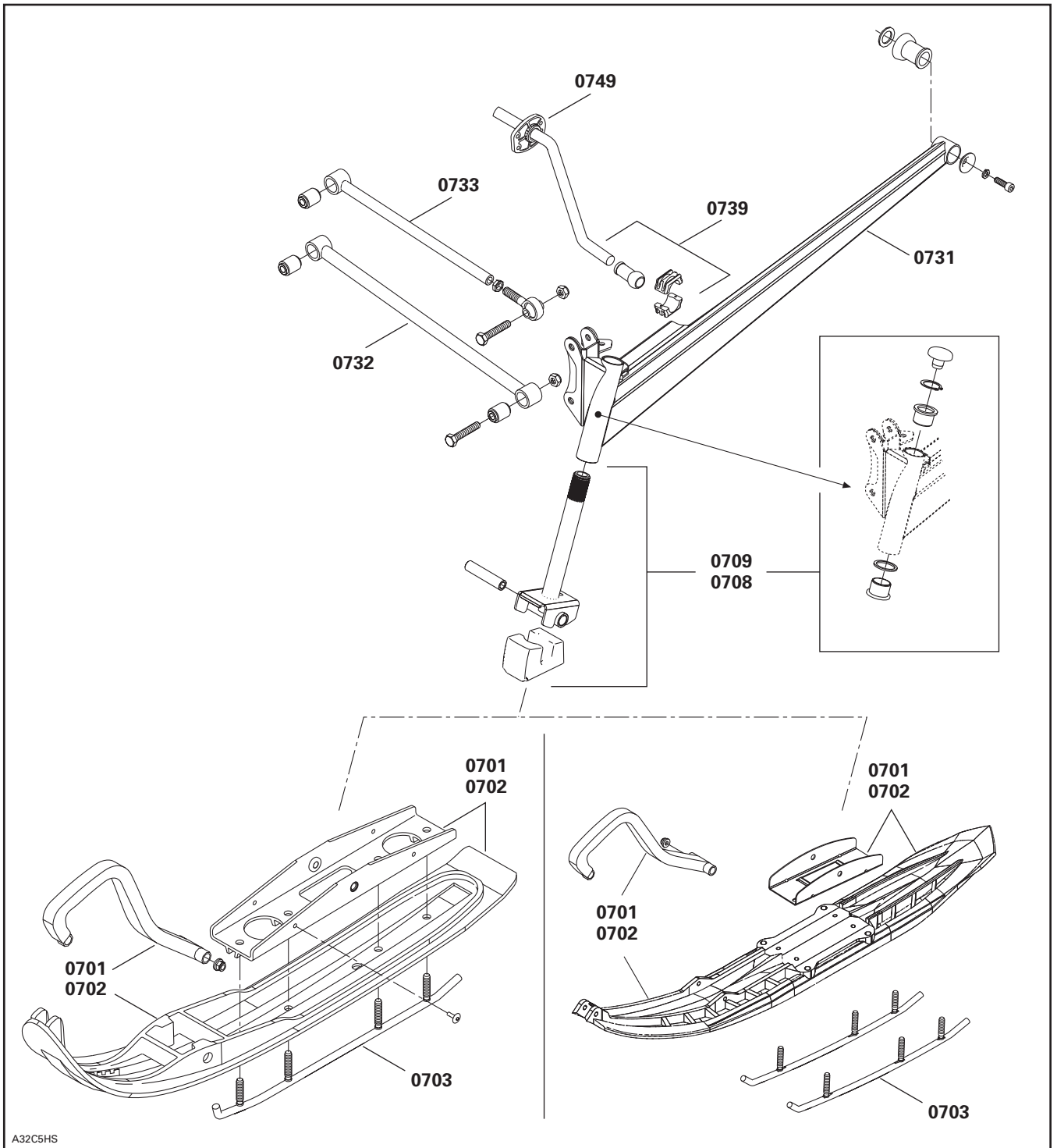

STEERING SYSTEM AND FRONT SUSPENSION SYSTÈME DE DIRECTION ET SUSPENSION AVANT

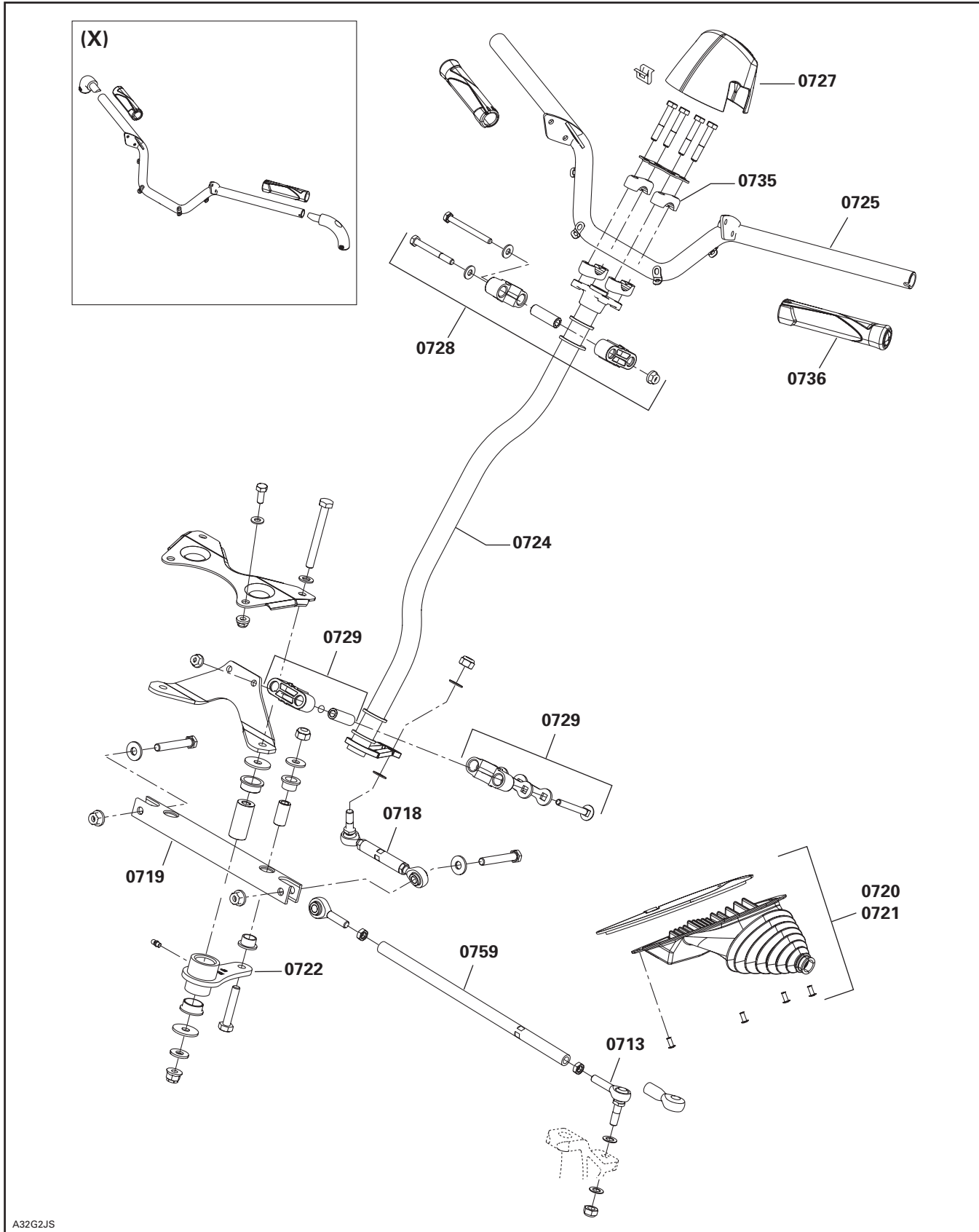

STEERING SYSTEM AND FRONT SUSPENSION SYSTÈME DE DIRECTION ET SUSPENSION AVANT

07
SYSTEM/SYSTEME

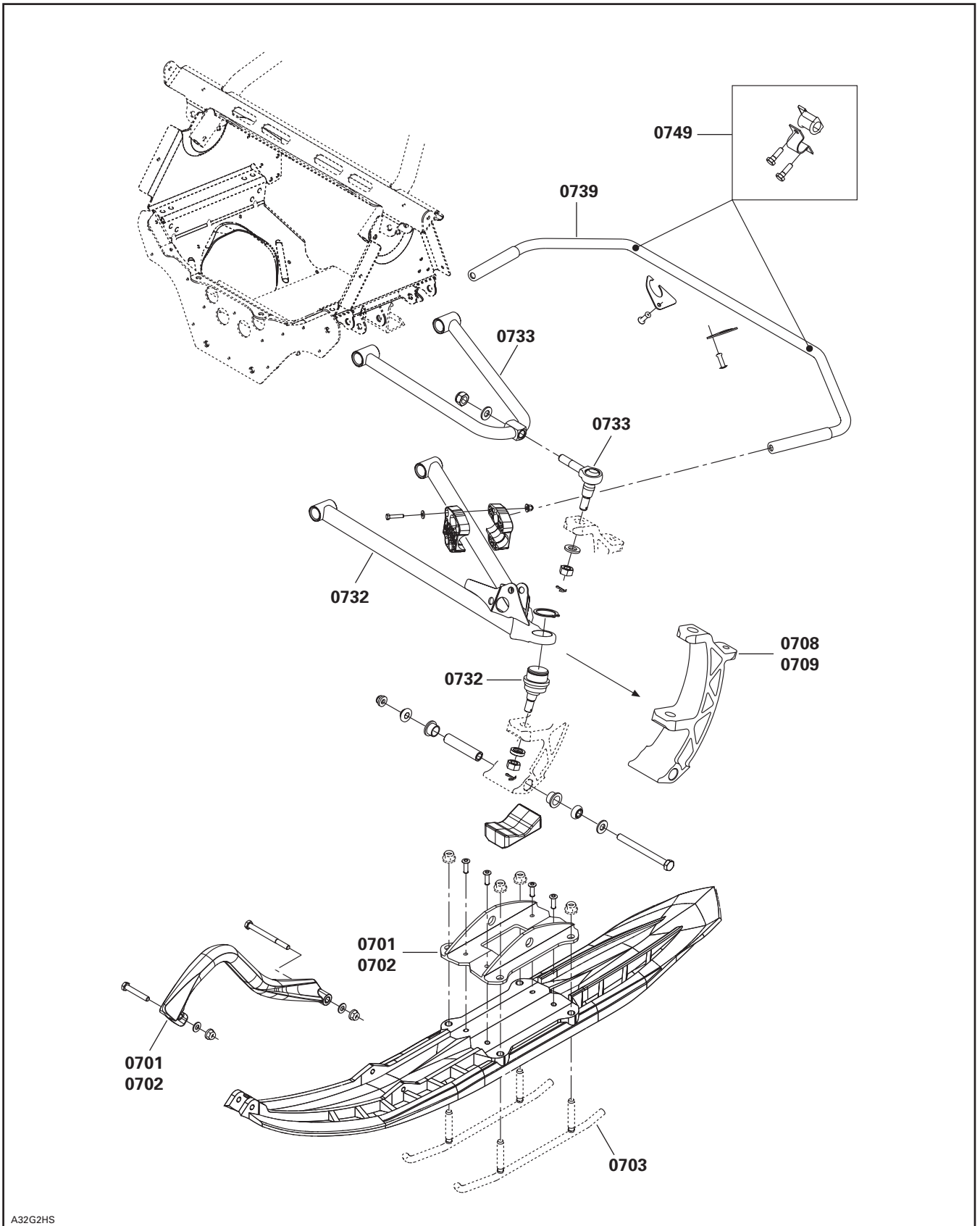

SYSTEM SYSTÈME	CODE	DESCRIPTION	MX Z 800 X/SPORT	MX Z 800 ADRENALINE/ RENEGADE	LEGEND 800 SE SDI	SUMMIT 800 HM X/HM	SUMMIT 800 X ADRENALINE	GRAND TOURING 800 SE SDI
			28	29	30	31	32	33
08	00	NO LABOR INVOLVED AUCUNE MAIN-D'OEUVRE IMPLIQUÉE	0	0	0	0	0	0
08	01	SLIDER SHOE (1) GLISSIÈRE (1)	0.5	0.5	0.5	0.5	0.5	0.5
08	02	SLIDER SHOES (2) GLISSIÈRES (2)	0.7	0.7	0.7	0.7	0.7	0.7
08	03	RUNNER (1) PORTE-GLISSIÈRE (1)	1.2	1.2	1.2	1.2	1.2	1.2
08	04	RUNNERS (2) PORTE-GLISSIÈRES (2)	1.5	1.5	1.5	1.5	1.5	1.5
08	09	FRONT IDLER WHEEL AND/OR BEARING (1) ROUE DE SUPPORT AVANT ET/OU ROULEMENT (1)	0.3	0.3	0.3	0.3	0.3	0.3
08	10	FRONT IDLER WHEELS AND/OR BEARINGS AND/OR SHAFTS (2) ROUES DE SUPPORT AVANT ET/OU ROULEMENTS ET/OU ARBRES (2)	0.4	0.4	0.4	0.4	0.4	0.4
08	11	FRONT IDLER WHEEL SUPPORT (1) SUPPORT DE ROUE AVANT (1)	0.3	0.3	0.3	0.3	0.3	0.3
08	12	FRONT IDLER WHEELS SUPPORTS (2) SUPPORTS DE ROUE AVANT (2)	0.4	0.4	0.4	0.4	0.4	0.4
08	13	CENTER IDLER WHEEL AND/OR BEARING (1) ROUE DE SUPPORT CENTRALE ET/OU ROULEMENT (1)	0.3	0.3	0.3	0.3	0.3	0.3
08	14	CENTER IDLER WHEELS AND/OR BEARINGS AND/OR SHAFTS (2) ROUES DE SUPPORT CENTRALES ET/OU ROULEMENTS ET/OU ARBRES (2)	0.4	0.4	0.4	0.4	0.4	0.4
08	15	CENTER IDLER WHEEL SUPPORT (1) SUPPORT DE ROUE CENTRALE (1)	0.3	0.3	0.3	0.3	0.3	0.3
08	17	REAR IDLER AND/OR BEARING (1) ROUE DE SUPPORT ARRIÈRE ET/OU ROULEMENT (1)	0.4	0.4	0.4	0.4	0.4	0.4
08	18	REAR IDLERS AND/OR BEARINGS (2) ROUES DE SUPPORT ARRIÈRE ET/OU ROULEMENTS (2)	0.5	0.5	0.5	0.5	0.5	0.5
08	19	REAR IDLER WHEELS AXLE ESSIEU DE ROUES DE SUPPORT ARRIÈRE	0.5	0.5	0.5	0.5	0.5	0.5
08	29	AXEL (stopper strap) AXE (courroie d'arrêt)	0.3	0.3	0.3	0.3	0.3	0.3
08	31	TRACK TENSION ADJUSTER (1) PLAQUE DE RÉGLAGE TENSION CHENILLE (1)	0.3	0.3	0.3	0.3	0.3	0.3
08	32	TRACK TENSION ADJUSTERS (2) PLAQUES DE RÉGLAGE TENSION CHENILLE (2)	0.4	0.4	0.4	0.4	0.4	0.4
08	33	RUNNER RUBBER STOPPER (1) BUTÉE DE CAOUTCHOUC DE PORTE-GLISSIÈRE (1)	0.3	0.3	0.3	0.3	0.3	0.3
08	34	RUNNER RUBBER STOPPERS (2) BUTÉES DE CAOUTCHOUC DE PORTE-GLISSIÈRE (2)	0.4	0.4	0.4	0.4	0.4	0.4

REAR SUSPENSION AND TRACK SUSPENSION ARRIÈRE ET CHENILLE

08

SYSTEM/SYSTEME

SYSTEM SYSTÈME	CODE	DESCRIPTION	MX Z 800 X/SPORT	MX Z 800 ADRENALINE/ RENEGADE	LEGEND 800 SE SDI	SUMMIT 800 HM X/HM	SUMMIT 800 X ADRENALINE	GRAND TOURING 800 SE SDI
			28	29	30	31	32	33
08	35	FRONT ARM AND/OR AXLE BRAS AVANT ET/OU ESSIEU	0.8	0.8	0.8	0.8	0.8	0.8
08	36	FRONT ARM STOPPER STRAP/STOPPER BOLT COURROIE D'ARRÊT BRAS AVANT/BOULON D'ARRÊT	0.3	0.3	0.3	0.3	0.3	0.3
08	40	REAR ARM AND/OR AXLE BRAS ARRIÈRE ET/OU ESSIEU	0.7	0.7	0.7	0.7	0.7	0.7
08	41	REAR ARM IDLER WHEELS (1-2) AND/OR SHAFT-CROSS ROUES DE SUPPORT BRAS ARRIÈRE (1-2) ET/OU AXE TRANSVERSALE	0.3	0.3	0.3	0.3	0.3	0.3
08	42	REAR ARM SHACKLE JUMELLE DE BRAS ARRIÈRE	0.3	0.3	0.3	0.3	0.3	0.3
08	44	REAR AND FRONT ARMS BRAS ARRIÈRE ET AVANT	1.5	1.5	1.5	1.5	1.5	1.5
08	50	REAR TORSION SPRING AND/OR WHEEL (1) RESSORT DE TORSION ARRIÈRE ET/OU ROUE (1)	0.3	0.3	0.3	0.3	0.3	0.3
08	51	REAR TORSION SPRINGS AND/OR WHEELS (2) RESSORTS DE TORSION ET/OU ROUES (2)	0.4	0.4	0.4	0.4	0.4	0.4
08	52	TORSION SPRING SUPPORT SUPPORT DE RESSORT DE TORSION	0.3	0.3	0.3	0.3	0.3	0.3
08	53	SPRING ADJUSTMENT CAM (1) CAME DE RÉGLAGE DE RESSORT (1)	0.3	0.3	0.3	0.3	0.3	0.3
08	54	SPRING ADJUSTMENT CAMS (2) CAMES DE RÉGLAGE DE RESSORT (2)	0.4	0.4	0.4	0.4	0.4	0.4
08	55	SHOCK AND/OR SPRING AND/OR BUSHING AMORTISSEUR ET/OU RESSORT ET/OU DOUILLE	0.3	0.3	0.3	0.3	0.3	
08	57	PRESSURE SENDER CAPTEUR DE PRESSION						0.5
08	61	ELECTRIC PRESSURE SENDER CAPTEUR DE PRESSION ÉLECTRIQUE						0.5
08	63	CENTER UPPER IDLER WHEELS AND/OR SHAFT (tunnel 1 or 2) ROUES DE SUPPORT CENTRALES INTÉRIEURES ET/OU ARBRE (tunnel 1 ou 2)	0.3	0.3	0.3	0.3	0.3	0.3
08	65	BEARING HOUSING OUTSIDE (drive axle) LOGEMENT DES ROULEMENTS D'EXTÉRIEUR (essieu moteur)	0.3	0.3	0.3	0.3	0.3	0.3
08	66	DRIVE AXLE BEARING AND/OR SEAL ROULEMENT D'ESSIEU MOTEUR ET/OU JOINT	2.3	2.3	2.3	2.3	2.3	2.3
08	67	DRIVE AXLE, SPROCKET AND/OR FLANGE (1) ROUE DENTÉE, ESSIEU MOTEUR ET/OU FLASQUE (1)	2.5	2.5	2.5	2.5	2.5	2.5
08	68	DRIVE AXLES, SPROCKETS, FLANGES (2 or more) ROUES DENTÉES, ESSIEUX MOTEUR, FLASQUES (2 ou plus)	3.1	3.1	3.1	3.1	3.1	3.1
08	69	TRACK (1) CHENILLE (1)	1.6	1.6	1.6	1.6	1.6	1.6
08	71	CLEATS AND/OR GUIDES (0-9) SEGMENTS GUIDE ET/OU GUIDES (0-9)	0.3	0.3	0.3	0.3	0.3	0.3

SYSTEM SYSTÈME	CODE	DESCRIPTION	MX Z 800 X/SPORT	MX Z 800 ADRENALINE/ RENEGADE	LEGEND 800 SE SDI	SUMMIT 800 HM X/HM	SUMMIT 800 X ADRENALINE	GRAND TOURING 800 SE SDI
			28	29	30	31	32	33
08	72	CLEATS AND/OR GUIDES (10-14) SEGMENTS GUIDE ET/OU GUIDES (10-14)	0.4	0.4	0.4	0.4	0.4	0.4
08	73	CLEATS AND/OR GUIDES (15-19) SEGMENTS GUIDE ET/OU GUIDES (15-19)	0.5	0.5	0.5	0.5	0.5	0.5
08	74	CLEATS AND/OR GUIDES (20-24) SEGMENTS GUIDE ET/OU GUIDES (20-24)	0.6	0.6	0.6	0.6	0.6	0.6
08	75	CLEATS AND/OR GUIDES (25-29) SEGMENTS GUIDE ET/OU GUIDES (25-29)	0.7	0.7	0.7	0.7	0.7	0.7
08	76	CLEATS AND/OR GUIDES (30-34) SEGMENTS GUIDE ET/OU GUIDES (30-34)	0.8	0.8	0.8	0.8	0.8	0.8
08	77	CLEATS AND/OR GUIDES (35-39) SEGMENTS GUIDE ET/OU GUIDES (35-39)	0.9	0.9	0.9	0.9	0.9	0.9
08	78	CLEATS AND/OR GUIDES (40-44) SEGMENTS GUIDE ET/OU GUIDES (40-44)	1.0	1.0	1.0	1.0	1.0	1.0
08	79	CLEATS AND/OR GUIDES (45-49) SEGMENTS GUIDE ET/OU GUIDES (45-49)	1.1	1.1	1.1	1.1	1.1	1.1
08	80	CLEATS AND/OR GUIDES (50-54) SEGMENTS GUIDE ET/OU GUIDES (50-54)	1.2	1.2	1.2	1.2	1.2	1.2
**		DRIVE AXLE SPROCKET REPOSITIONNING REPOSITION DE BARBOTIN D'ESSIEU	0.4	0.4	0.4	0.4	0.4	0.4
08	85	ADJUSTMENT SCREW (1) VIS D'AJUSTEMENT (1)	0.3	0.3	0.3	0.3	0.3	0.3
08	86	ADJUSTMENT SCREWS (2) VIS D'AJUSTEMENT (2)	0.4	0.4	0.4	0.4	0.4	0.4
08	87	SHOCK SUPPORT AND/OR AXLE SUPPORT D'AMORTISSEUR ET/OU AXE	0.4	0.4	0.4	0.4	0.4	0.4
08	88	FRONT SHOCK AND/OR SPRING AMORTISSEUR AVANT ET/OU RESSORT	0.5	0.5	0.5	0.5	0.5	0.5
08	89	FRONT IDLER WHEELS AND/OR BEARINGS (3 or 4) ROUES DE SUPPORT AVANT ET/OU ROULEMENTS (3 ou 4)	0.5	0.5	0.5	0.5	0.5	0.5
08	90	FRONT IDLER WHEELS AND/OR BEARINGS (5 or 6) ROUES DE SUPPORT AVANT ET/OU ROULEMENTS (5 ou 6)	0.7	0.7	0.7	0.7	0.7	0.7
08	94	FRONT IDLER WHEELS (inside) ROUES DE SUPPORT AVANT (intérieur)	1.0	1.0	1.0	1.0	1.0	1.0
08	119	MAGNETIC SENSOR CAPTEUR MAGNÉTIQUE	0.3	0.3	0.3	0.3	0.3	0.3

REAR SUSPENSION AND TRACK SUSPENSION ARRIÈRE ET CHENILLE

08
SYSTEM/SYSTEME

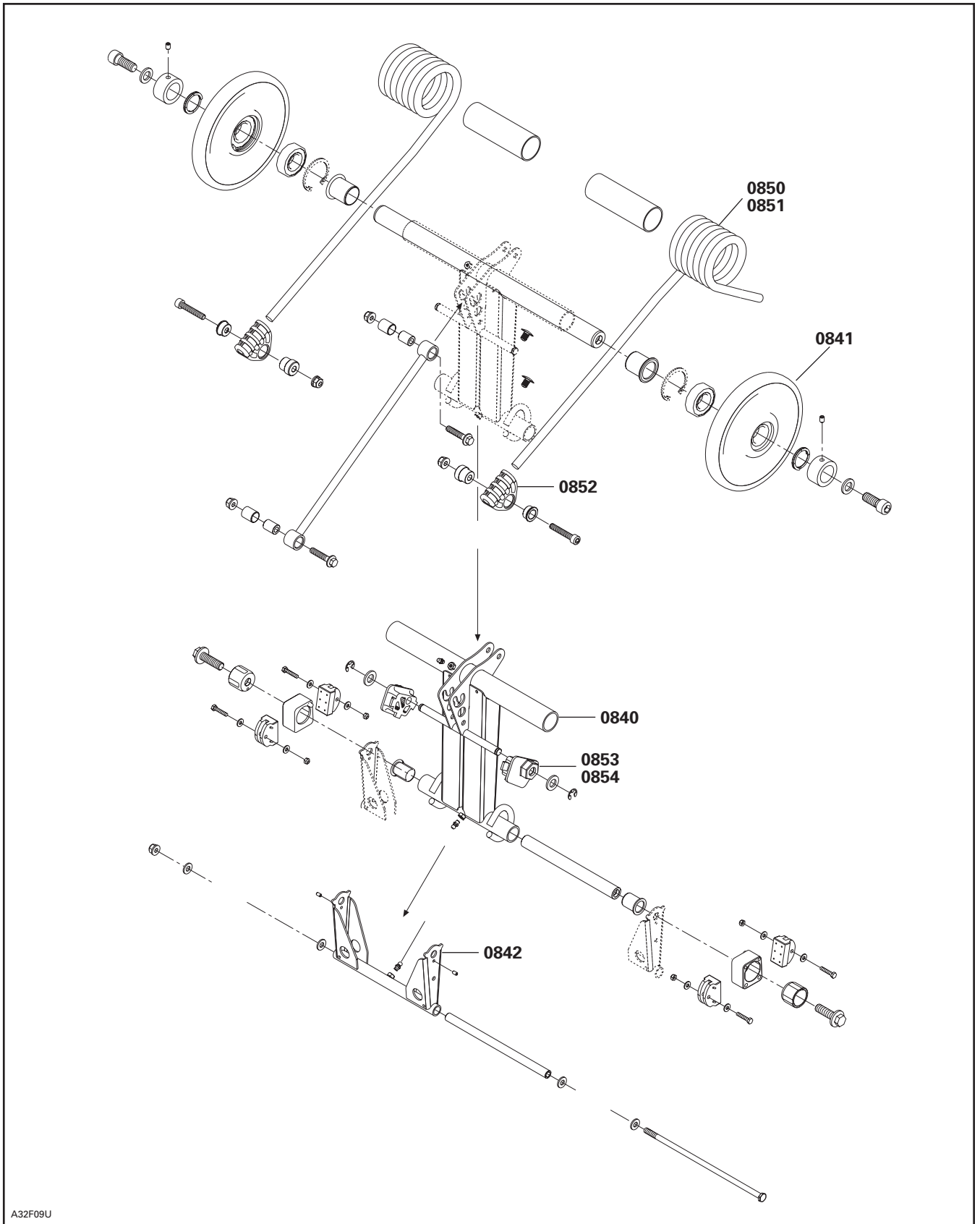

REAR SUSPENSION AND TRACK SUSPENSION ARRIÈRE ET CHENILLE

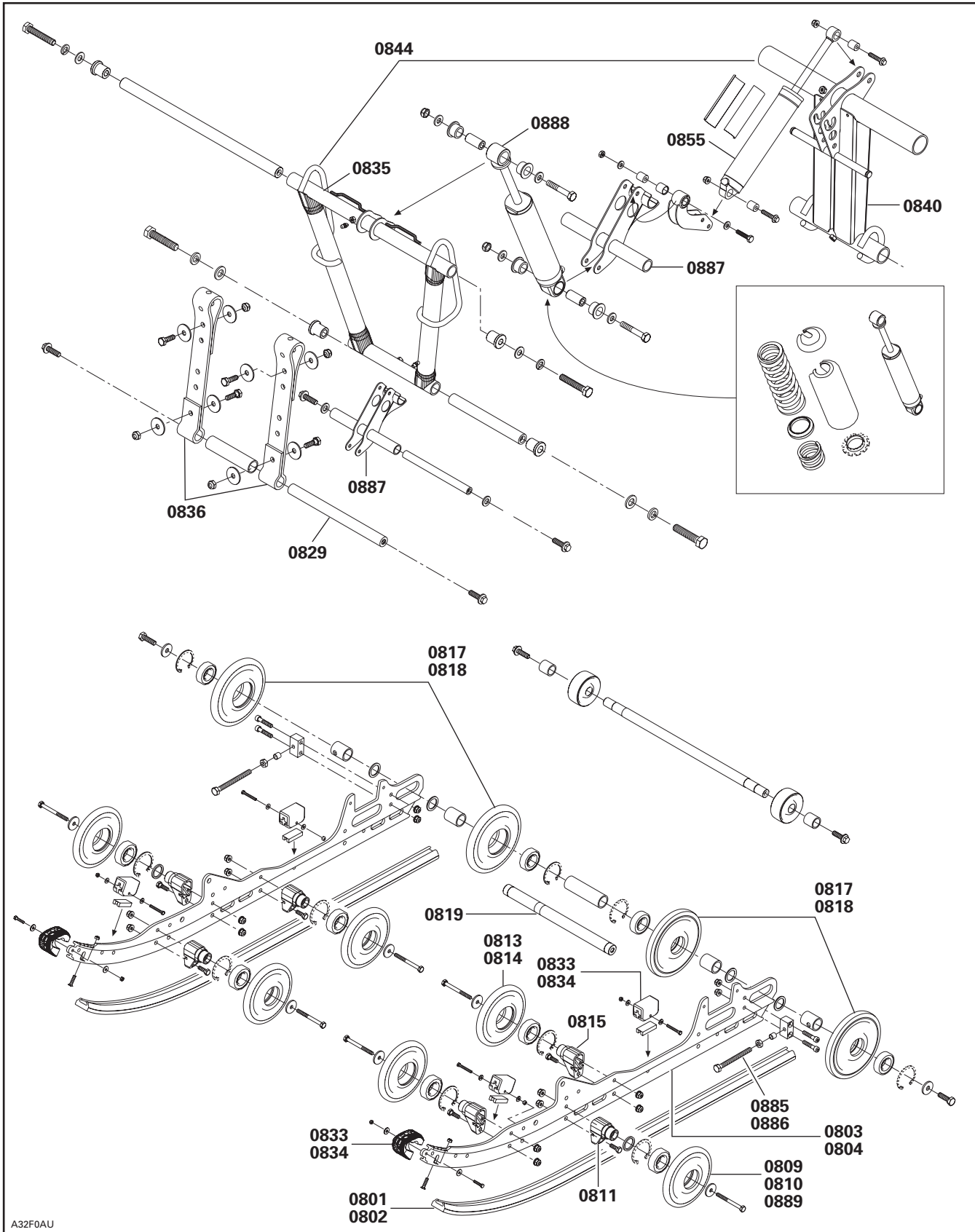

A32F0AU

SYSTEM SYSTÈME	CODE	DESCRIPTION	MX Z 800 X/SPORT	MX Z 800 ADRENALINE/ RENEGADE	LEGEND 800 SE SDI	SUMMIT 800 HM X/HM	SUMMIT 800 X ADRENALINE	GRAND TOURING 800 SE SDI
			28	29	30	31	32	33
09	00	NO LABOR INVOLVED AUCUNE MAIN-D'OEUVRE IMPLIQUÉE	0	0	0	0	0	0
09	01	HOOD CAPOT	0.4	3.0	3.0	3.0	3.0	3.0
09	03	HOOD HINGE CHARNIÈRE DU CAPOT	0.3	0.3	0.3	0.3	0.3	0.3
09	05	CAB DECALS (RH or LH) AUTOCOLLANTS DE LA CABINE (G ou D)	0.3	0.3	0.3	0.3	0.3	0.3
09	06	CAB DECALS (all) AUTOCOLLANTS DE LA CABINE (tous)	0.9	0.9	0.9	0.9	0.9	0.9
09	07	CAB LATCH (1 or 2) ATTACHE DE LA CABINE (1 ou 2)	0.3	0.3	0.3	0.3	0.3	0.3
09	09	WINDSHIELD PARE-BRISE	0.3	0.3	0.3	0.3	0.3	0.3
09	13	CARGO RACK SUPPORT À BAGAGES				0.4	0.4	0.4
09	14	FRONT BUMPER PARE-CHOC AVANT	0.3	0.4	0.4	0.4	0.4	0.4
09	17	CONSOLE CONSOLE	0.4	1.2	1.2	1.2	1.2	1.2
09	21	SEAT ASS'Y OR BACKREST SIÈGE COMPLET OU DOSSIER	0.3	0.3	0.3	0.3	0.3	0.3
09	22	SEAT COVER AND/OR FOAM HOUSSE DE SIÈGE ET/OU MOUSSE	1.1	1.1	1.1	1.1	1.1	1.5
09	24	BOTTOM PAN COQUE		2.0	2.0	2.0	2.0	2.0
09	30	REAR FOOTREST REPOSE-PIED ARRIÈRE						0.3
09	33	RADIATOR RADIATEUR	3.9	3.6	3.6	3.6	3.6	3.6
09	34	REAR BUMPER PARE-CHOC ARRIÈRE	0.3	0.3	0.3	0.3	0.3	0.3
09	48	FRONT FOOTREST (LH or RH) REPOSE-PIED AVANT (G ou D)	0.6	0.6	0.6	0.6	0.6	0.6
09	49	FRAME ASS'Y CHÂSSIS COMPLET	13.8	11.6	11.6	11.6	11.6	11.6
09*	50	FRAME FORMING (tunnel) TUNNEL		14.1	14.1	14.1	14.1	14.1
09	51	REAR CAP FRAME CAPUCHON ARRIÈRE DU CHÂSSIS		0.7	0.7	0.7	0.7	0.7

SYSTEM SYSTÈME	CODE	DESCRIPTION	MX Z 800 X/SPORT	MX Z 800 ADRENALINE/ RENEGADE	LEGEND 800 SE SDI	SUMMIT 800 HM X/HM	SUMMIT 800 X ADRENALINE	GRAND TOURING 800 SE SDI
			28	29	30	31	32	33

09	55	SNOW GUARD (1) GARDE-NEIGE (1)	0.3	0.3	0.3	0.3	0.3	0.3
09	58	BACKREST AND/OR COVER DOSSIER ET/OU HOUSSE						0.3
09	59	BACKREST ARM BRAS DU DOSSIER						0.3
09	62	BOTTOM PAN REINFORCEMENT (RH) RENFORT DE COQUE (D)		0.7	0.7	0.7	0.7	0.7
09	63	BOTTOM PAN REINFORCEMENT (LH) RENFORT DE COQUE (G)		0.7	0.7	0.7	0.7	0.7
09	64	SEAT BELT COURROIE DE SIÈGE						0.3
09	65	MIRROR (1) RÉTROVISEUR (1)			0.3			0.3
09	66	MIRRORS (2) RÉTROVISEURS (2)			0.3			0.3
09	77	RH BOTTOM PAN COQUE CÔTÉ DROIT	0.7					
09	78	LH BOTTOM PAN COQUE CÔTÉ GAUCHE	0.7					
09	79	CENTER BOTTOM PAN COQUE PARTIE CENTRALE	0.5					
09	80	FRONT GRILL (RH and/or LH) GRILLE AVANT (G et/ou D)	0.3	0.3	0.3	0.3	0.3	0.3
09	81	SIDE GRILL (RH and/or LH) GRILLE LATÉRALE (G et/ou D)	0.3	0.3	0.3	0.3	0.3	0.3
09	138	HAND PROTECTOR PROTÈGE MAIN	0.3					
09	149	ENGINE SIDE PANELS (2) PANNEAUX MOTEUR (2)	0.3					
09	156	FRONT FRAME CHÂSSIS AVANT	5.9					

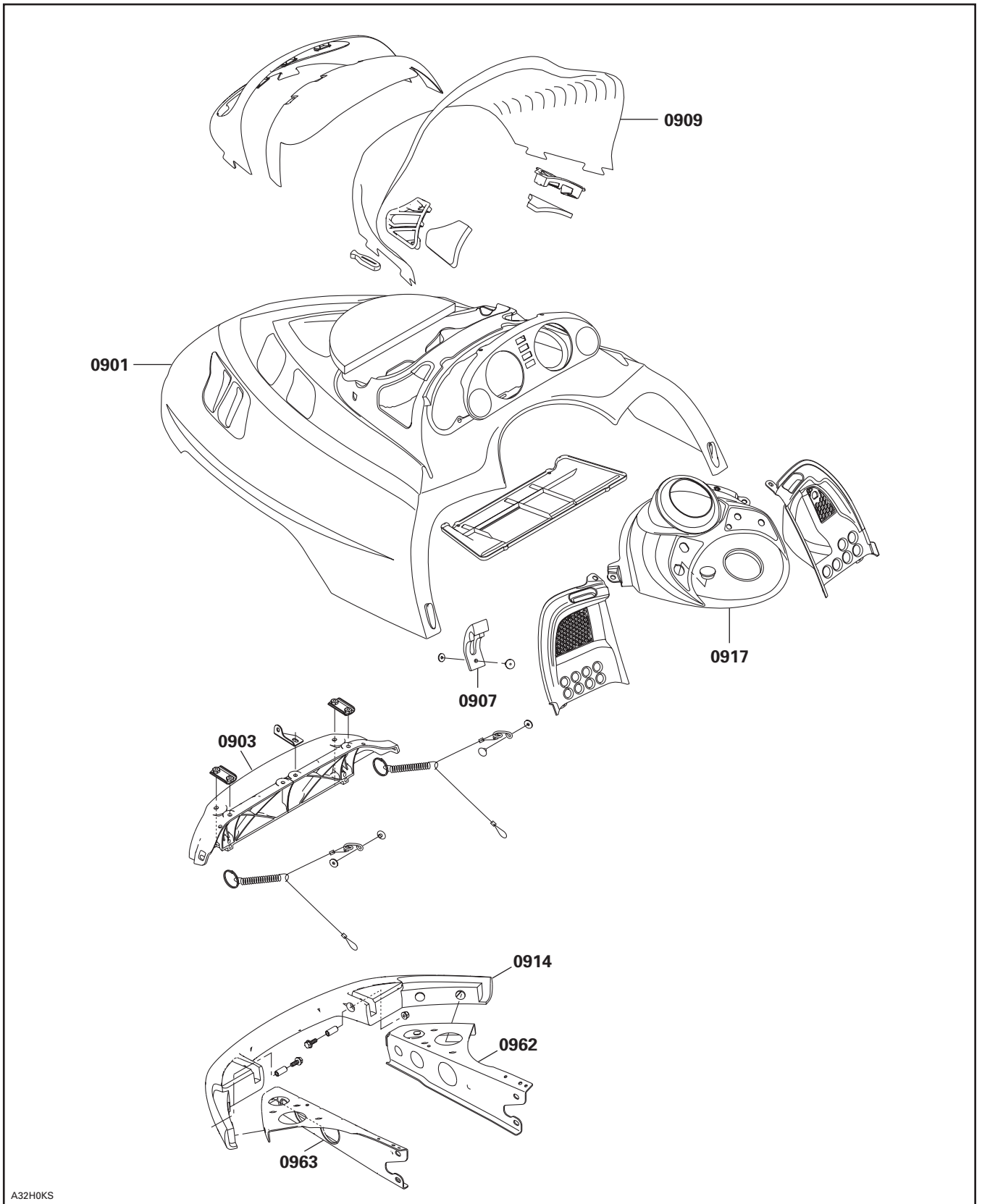

A32H0KS

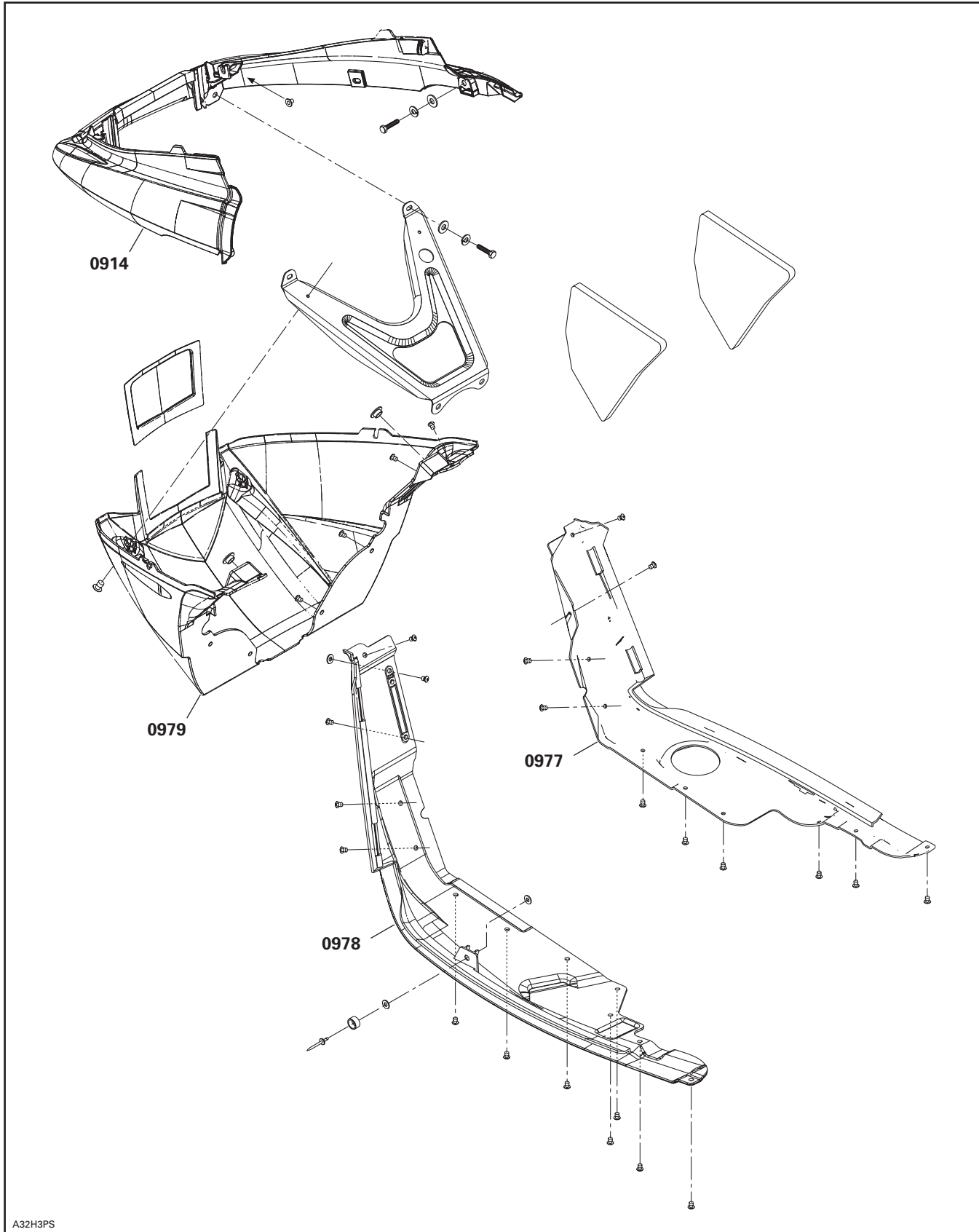

A32H3PS

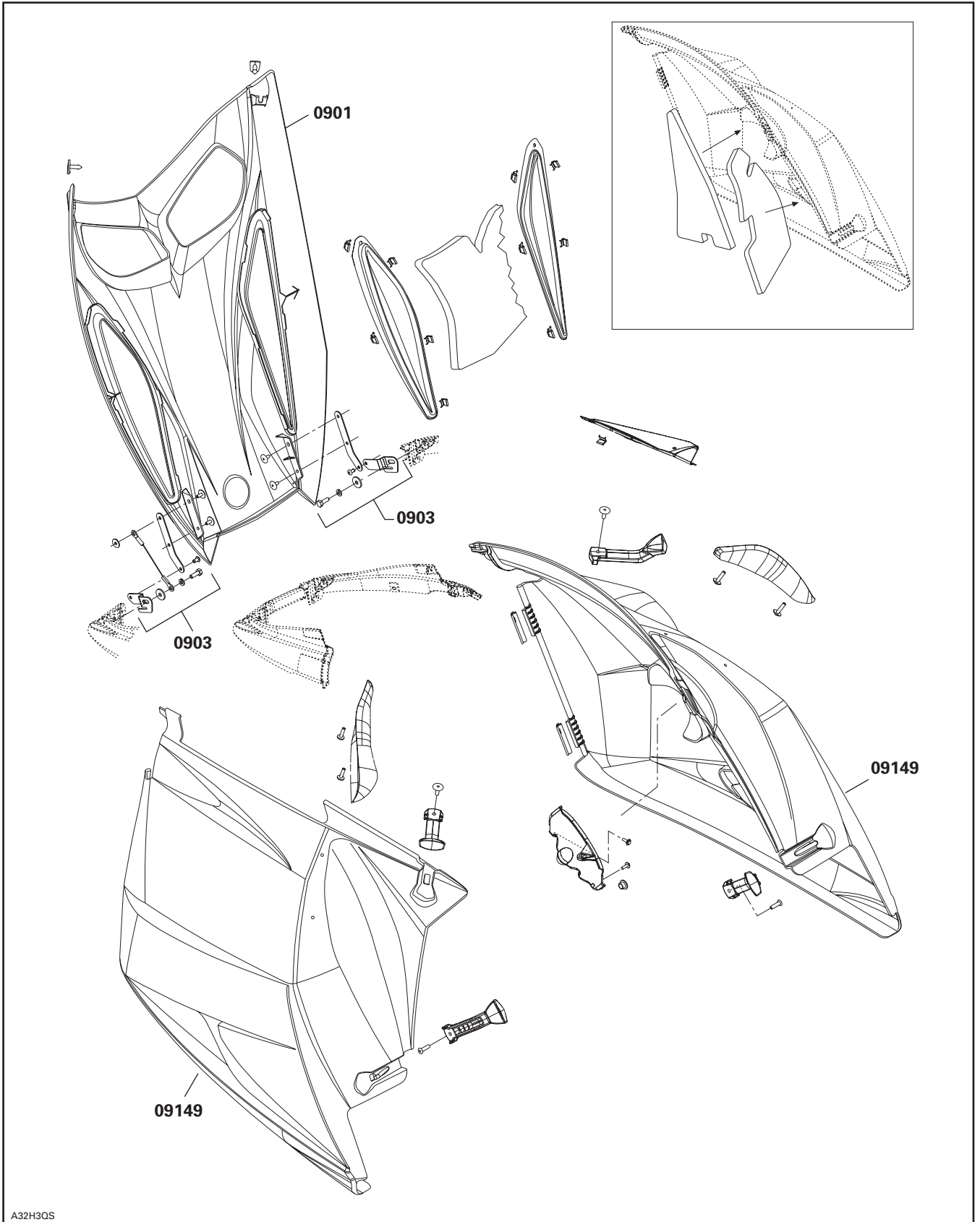

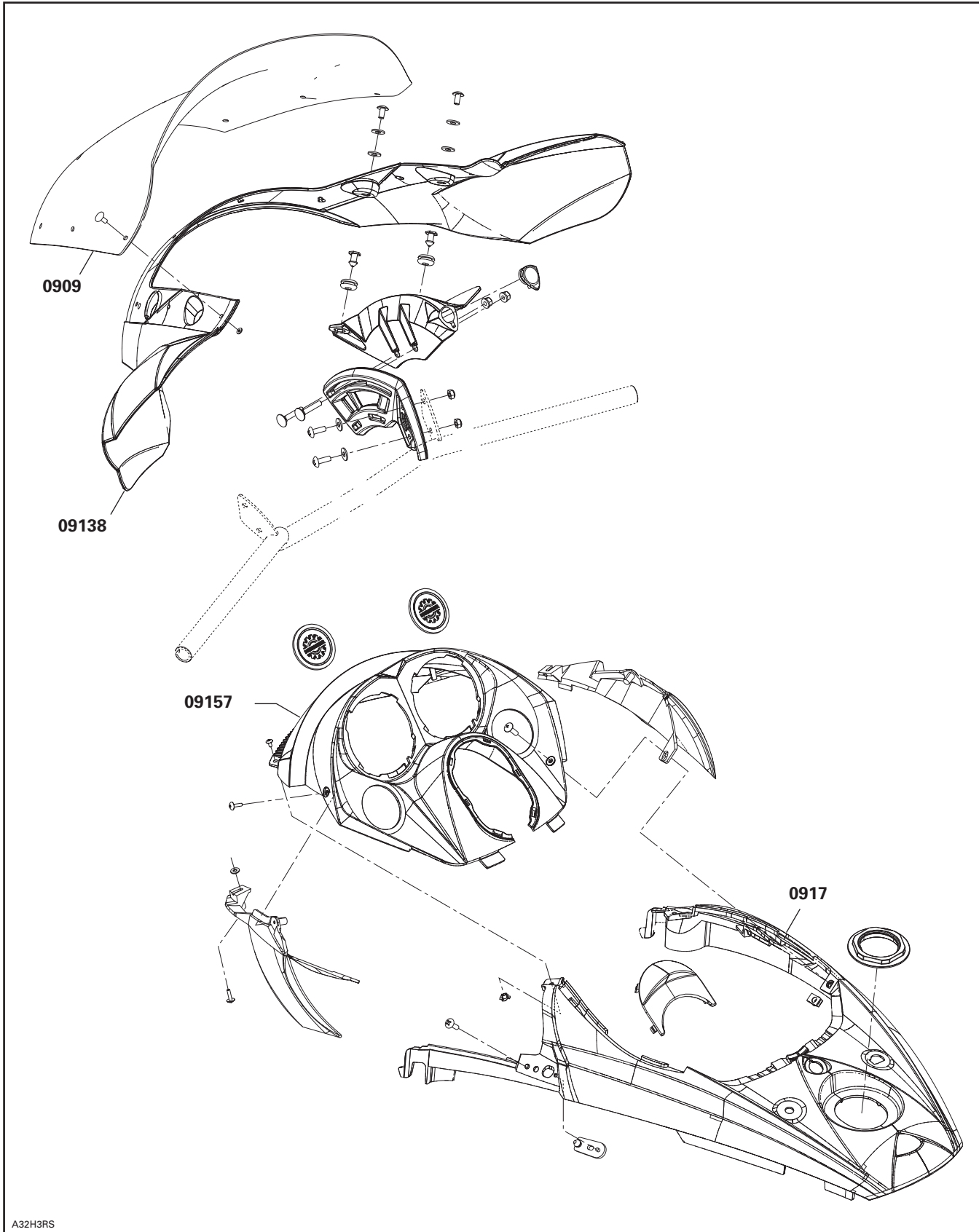

A32H3RS

SYSTEM SYSTÈME	CODE	DESCRIPTION	MX Z 800 X/SPORT	MX Z 800 ADRENALINE/ RENEGADE	LEGEND 800 SE SDI	SUMMIT 800 HM X/HM	SUMMIT 800 X ADRENALINE	GRAND TOURING 800 SE SDI
			28	29	30	31	32	33
10	00	NO LABOR INVOLVED AUCUNE MAIN-D'OEUVRE IMPLIQUÉE	0	0	0	0	0	0
10	01	IGNITION SWITCH INTERRUPTEUR D'ALLUMAGE	0.3	0.3	0.3	0.3	0.3	0.3
10	05	BRAKE LIGHT SWITCH INTERRUPTEUR DE FEU D'ARRÊT	0.3	0.3	0.3	0.3	0.3	0.3
10	06	TETHER CORD SWITCH OR DESS CAPUCHON COUPE-CIRCUIT OU DESS	0.3	0.3	0.3	0.3	0.3	0.3
10	07	IGNITION SWITCH BLOCK LOGEMENT DE RÉCEPTACLE (interrupteur)	0.3	0.3	0.3	0.3	0.3	0.3
10	08	CURRENT OR GROUND WIRE FIL DE BATTERIE OU DE MASSE	0.3	0.3	0.3	0.3	0.3	0.3
10	09	HEADLAMP ASS'Y (all parts) PHARE COMPLET(toutes les pièces)	0.3	0.3	0.3	0.3	0.3	0.3
10	10	VOLTAGE REGULATOR RÉGULATEUR DE TENSION	0.4	0.3	0.3	0.3	0.3	0.3
10	12	TAIL LIGHT ASS'Y (all parts) FEU ARRIÈRE COMPLET (toutes les pièces)	0.3	0.3	0.3	0.3	0.3	0.3
10	13	BATTERY RACK, RETAINER ROD AND/OR RETAINER BATTERIE SUPPORT, TIGE DE RETENUE ET/OU COUVERCLE DE RETENU	0.3	0.3	0.3	0.3	0.3	0.3
10	15	HEATED GRIPS POIGNÉES CHAUFFANTES	0.4	0.4	0.4	0.4	0.4	0.4
10	16	BULBS (one or all) AMPOULES (une ou toutes)	0.3	0.3	0.3	0.3	0.3	0.3
10	20	BACK UP BUZZER AVERTISSEUR DE MARCHE ARRIÈRE	0.3	0.3	0.3	0.3	0.3	0.3
10	28	SPEEDOMETER OR TACHOMETER (all parts) INDICATEUR DE VITESSE OU COMPTE-TOURS (toutes pièces)	0.3	0.3	0.3	0.3	0.3	0.3
10	34	ELECTRONIC MODULE MODULE ÉLECTRONIQUE	0.3	0.3	0.3	0.3	0.3	0.3
10	44	FUEL GAUGE/TEMPERATURE GAUGE AND COMPONENT INDICATEUR NIVEAU D'ESSENCE/TEMPÉRATURE ET COMPOSANTE			0.3			0.3

**CLAIM TYPE 02
RÉCLAMATION DE TYPE 02**

SYSTEM SYSTÈME	CODE	DESCRIPTION	MX Z 800 X/SPORT	MX Z 800 ADRENALINE/ RENEGADE	LEGEND 800 SE SDI	SUMMIT 800 HM X/HM	SUMMIT 800 X ADRENALINE	GRAND TOURING 800 SE SDI
			28	29	30	31	32	33
11	00	NO LABOR INVOLVED AUCUNE MAIN-D'OEUVRE IMPLIQUÉE	0	0	0	0	0	0

FLAT RATE TIME SUGGESTION

DEALER'S NO.: _____ DATE: _____

DEALER'S NAME: _____

FILE IDENTIFICATION NO.: _____

ADDRESS: _____

YEAR	MODEL DESCRIPTION	OPERATION	JOB CODE	PRESENT FLAT RATE	SUGGESTED FLAT RATE

Detailed procedure used:

Signature: _____

BOMBARDIER
RECREATIONAL PRODUCTS
WARRANTY DEPARTMENT
75, J.A. BOMBARDIER ST.
SHERBROOKE (QUEBEC)
CANADA, J1L 1W3

FAX NUMBER: 819-566-3590

**BARÈME DE TEMPS À TAUX FIXE
SUGGESTION**

N° DU CONCESSIONNAIRE: _____ DATE: _____

NOM DU CONCESSIONNAIRE: _____

N° D'IDENTIFICATION DU DOSSIER: _____

ADRESSE: _____

ANNÉE	DESCRIPTION DU MODÈLE	OPÉRATION	CODE DE TRAVAUX	TTP ACTUEL	TTP SUGGÉRÉ

Détails de la marche à suivre:

Signature: _____

BOMBARDIER
PRODUITS RÉCRÉATIF

SERVICE DE GARANTIE
75, RUE J.-A. BOMBARDIER
SHERBROOKE (QUÉBEC)
CANADA, J1L 1W3

N° DU TÉLÉCOPIEUR: 819-566-3590