

ski-doo 2004[®]

Racing Handbook



2004 RACING HANDBOOK

TABLE OF CONTENTS

| | Section |
|---|----------------|
| CONTACTING THE RACE DEPARTMENT | 01-1 |
| 2004 MODELS TECHNICAL DATA..... | 02-1 |
| CHASSIS PREPARATION | 03-1 |
| ENGINE PREPARATION | 04-1 |
| DRIVE SYSTEM | 05-1 |
| 2004 800 MOD ENGINE KIT | 06-1 |
| 2003 MX Zx 440 INFORMATION | 07-1 |
| COMPETITION PREPARATION | 08-1 |
| SERVICE TOOLS..... | 09-1 |
| ACCESSORIES..... | 10-01 |

WARNING

This information relates to the preparation and use of snowmobiles in competitive events. Bombardier Inc. disclaims liability for all damages and/or injuries resulting from the improper use of the contents. We strongly recommend that these modifications be carried out and/or verified by a highly-skilled professional racing mechanic. It is understood that racing or modifications of any Bombardier-made snowmobile voids the vehicle warranty and that such modifications may render use of the vehicle illegal in other than sanctioned racing events under existing federal, provincial and state regulations.

KEEPING YOUR MACHINE LEGAL IS YOUR RESPONSIBILITY

Read the rule book and/or contact organization you will be competing in.

RACE DEPARTMENT CONTACTS

U.S. & CDN RACERS (ENGLISH)

Steve Cowing

Race Marketing and Communications Manager

24078 Greenway Rd. Unit #4

Forest Lake MN. 55025

Phone: 651 982-6223

Fax:651 982-6225

E-mail: steve.cowing@recreation.bombardier.com

- Race Program
- Race Resumes
- Race Sleds Allocation
- Marketing and Communication
- Press Events
- Dealer Programs

Tom Lawrence

Race Coordinator

7575 Bombardier Court

Wausau WI. 54401

Phone: 715-848-4971

Fax: 715-847-6879

E-mail: tom.lawrence@recreation.bombardier.com

- Technical Support
- Race Schools
- Race Manual
- MPEM Programming

Parts Order

All Part Numbers with a 486 prefix must be ordered from the Valcourt Race Dept. or the Ski Doo Race Support Truck. Please use order form on page 1-4 or 1-5. Order form must be filled out completely to have your order processed. All other part numbers MUST be ordered thru your dealer.

Website: www.ski-doo.com/racingzone

- Race Schedule and Results

NOTE: E-mail is the preferred method of communications throughout the year.

SECTION 01 - CONTACTING THE RACE DEPARTMENT

CDN RACERS (FRENCH SPEAKING RACERS ONLY)

Marcel Imbeault
Race Manager

565, de la Montagne
Valcourt, QC J0E 2L0

Phone: 450-532-2211 Ext. 5479

Fax: 450-532-6175

E-mail: marcel.imbeault@recreation.bombardier.com

- Race Program
- Race Resumes
- Race Sleds Allocation

Hélène Despaties
Race Manager Assistant

565, de la Montagne
Valcourt, QC J0E 2L0

Phone: 450-532-2211 Ext. 5075

Fax: 450-532-6175

E-mail: helene.despaties@recreation.bombardier.com

- T.I.P. Sheet Distribution (See T.I.P. Sheet Application on Page 1-3)

Yvon Petit
Race Technician

565, de la Montagne
Valcourt QC. J0E 2L0

Phone: 450-532-2211 Ext. 5803

Fax: 450-532-6175

E-mail: yvon.petit@recreation.bombardier.com

- Technical Support

Parts Order

All Part Numbers with a 486 prefix must be ordered from the Valcourt Race Dept. Please use order form on page 1-4. Order form must be filled out completely to have your order processed. All other part numbers MUST be ordered through your dealer.

Website: www.ski-doo.com/racingzone

- Race Schedule and Results

NOTE: E-mail is the preferred method of communications throughout the year.



**T.I.P.
SHEET
APPLICATION**

TECHNICAL INFORMATION POSTING

This form only will be accepted
Last year applications are not valid anymore

Dear Ski-Doo X-Team

Please add my name to your list of recipients for the T.I.P. sheets to be distributed during the 2003-04 race season.

Name: _____ City: _____

To receive the T.I.P. sheets by e-mail, send an e-mail to the following:

helene.despaties@recreation.bombardier.com

and mention to add your address on the tip sheet distribution list

To receive the T.I.P. sheets by fax, send a fax to the following:

Fax to: H el ene Despaties at (450) 532-6175

Fax: _____ (your complete fax number)





and mention to add your name on the tip sheet distribution list

TABLE OF CONTENTS





| | |
|---|-------------|
| ENGINE | 02-2 |
| MX Z X 440 RACING (CAN./U.S.) | 02-2 |
| MX Z 600 HO /E/R/X/ ADRENALINE/RENEGADE/X (CAN./U.S.) | 02-2 |
| MX Z 800 HO/E/R/X/ ADRENALINE/RENEGADE/X (CAN./U.S.) | 02-2 |
| SUMMIT 600 HO/R/ ADRENALINE/X (CAN./U.S.) | 02-3 |
| SUMMIT 800 HO /R/ HIGHMARK/X/XTREME (CAN./U.S.) | 02-3 |
| SUMMIT 800 HO /R/ SPORT (CAN./U.S.) | 02-3 |
| VEHICLE | 02-4 |
| MX Z X 440 RACING (CAN./U.S.) | 02-4 |
| MX Z 600 HO R/X/ ADRENALINE(CAN./U.S.) | 02-4 |
| MX Z 600 E/R/ RENEGADE/X (CAN./U.S.) | 02-5 |
| MX Z 800 HO R/X/ ADRENALINE(CAN./U.S.)) | 02-5 |
| MX Z 800 E/R/ RENEGADE/X (CAN./U.S.) | 02-5 |
| SUMMIT 600 HO R/X/ ADRENALINE (CAN./U.S.) | 02-6 |
| SUMMIT 800 HO R/X/ ADRENALINE (CAN./U.S.) | 02-6 |
| SUMMIT 800 HO R HIGHMARK (CAN./U.S.) | 02-6 |
| SUMMIT 800 HO R HIGHMARK X (CAN./U.S.) | 02-7 |
| SUMMIT 800 HO R HIGHMARK XTREME (CAN./U.S.) | 02-7 |
| SUMMIT 800 HO R SPORT (CAN./U.S.) | 02-7 |
| ENGINE LEGEND | 02-8 |
| VEHICLE LEGEND | 02-8 |

SECTION 02 - 2004 MODELS TECHNICAL DATA

ENGINE



| VEHICLE MODEL | | MX Z X 440 RACING (CAN./U.S.) | MX Z 600 HO /E/R/X/ ADRENALINE/ RENEGADE/X (CAN./U.S.) | MX Z 800 HO/E/R/X/ ADRENALINE/ RENEGADE/X (CAN./U.S.) | | |
|--|---------------------------------------|---|---|--|-------------------------------|-------------------------------|
| ENGINE TYPE | | 453 | 593 | 793 | | |
|  | Number of Cylinders | 2 | 2 | 2 | | |
| | Bore | mm (in) | 65.0 (2.56) | 72.0 (2.835) | 82.0 (32.228) | |
| | Stroke | mm (in) | 65.8 (2.59) | 73.0 (2.874) | 75.70 (2.980) | |
| | Displacement | cm ³ (in ³) | 436.7 (26.6) | 594.40 (36.27) | 799.20 (48.77) | |
| | Compression Ratio | | 14.8 ± 0.25 | 12.25 ± 0.5 | 12.0 ± 0.5 | |
| | Maximum Power Engine Speed ① | ± 100 RPM | 8400 | 8000 | 7900 | |
| | Piston Ring Type | 1 st /2 nd | ST/N.A. | ST/N.A. | ST/N.A. | |
| | Ring End Gap | New | mm (in) | 0.4 (.0157) | 0.4 (.016) | 0.4 (.016) |
| | | Wear Limit | mm (in) | 1.0 (.040) | 1.0 (.039) | 1.0 (.039) |
| | Ring/Piston Groove Clearance | New | mm (in) | 0.04 (.0016) | 0.05 (.0020) | 0.05 (.0020) |
| | | Wear Limit | mm (in) | 0.2 (.0079) | 0.2 (.0079) | 0.2 (.0079) |
| | Piston/Cylinder Wall Clearance | New | mm (in) | 0.1150 (.0045) | 0.105 ± 0.023 (.0041 ± .0009) | 0.125 ± 0.023 (.0049 ± .0009) |
| | | Wear Limit | mm (in) | 0.20 (.0079) | 0.20 (.0079) | 0.20 (.0079) |
| Connecting Rod Big End Axial Play | New | mm (in) | 0.39 (.0154) | 0.310 (.0122) | 0.39 (.0154) | |
| | Wear Limit | mm (in) | 1.2 (.0472) | 1.2 (.0472) | 1.2 (.0472) | |
| Maximum Crankshaft End-play ② | mm (in) | 0.3 (.0118) | 0.3 (.012) | 0.3 (.012) | | |
| Maximum Crankshaft Deflection at PTO | mm (in) | 0.06 (.0024) | 0.06 (.0024) | 0.06 (.0024) | | |
|  | Magneto Generator Output | W | 290 | 360 | 360 | |
| | Ignition Type | | CDI | CDI | CDI | |
| | Spark Plug Make and Type | | NGK BR9ECS | NGK BR9ECS ③ | NGK BR9ECS ③ | |
| | Spark Plug Gap | ± 0.05 mm (± .002 in) | 0.45 (.018) ④ | 0.45 (.018) ④ | 0.45 (.018) ④ | |
| | Ignition Timing BTDC ③ | mm (in) | 3.14 (.124) | 2.79 (.110) | 2.92 (.115) | |
| | Trigger Coil ④ | Ω | 190 – 300 | 190 – 300 | 190 – 300 | |
| | Generating Coil ④ | Low Speed | Ω | 17.5 – 42.5 | N.A. | N.A. |
| | | High Speed | Ω | 2.4 - 5.8 | N.A. | N.A. |
| | Lighting Coil ④ | Ω | 0.1 – 0.4 | 0.1 – 1.0 | 0.1 – 1.0 | |
| | High Tension Coil ④ | Primary | Ω | 0.3 – 0.7 | N.A. | N.A. |
| Secondary | | kΩ | N.A. | N.A. | N.A. | |
|  | Carburetor Type | PTO/MAG | TMX 34-23/TMX 34-24 | TM 40-B238 | TM 40-B292 | |
| | Main Jet | PTO/MAG | 390 | 380/380 | 380/380 | |
| | Needle Jet | | Q-6 | P-0 ⑤ | P-0 ⑤ | |
| | Pilot Jet | | 25 | 17.5 | 17.5 | |
| | Needle Identification — Clip Position | PTO/MAG | 6FIY4 – 59 | 9DHI13-58 ⑥ | 9DG17-58 ⑥ | |
| | Slide Cut-Away | | 4.0 | 1.5 | 2.0 | |
| | Float Adjustment | ± 1 mm (± .040 in) | N.A. | N.A. | N.A. | |
| | Air or Pilot Screw Adjustment | ± 1/16 turn | 1.0 | 1-1/2 | 1.5 | |
| | Idle Speed | ± 200 RPM | 1800 | 1600 | 1500 | |
| | Gas Type/Pump Octane Number | | Super unleaded/91 ⑦ | Unleaded/87 | Unleaded/87 | |
| | Gas/Oil Ratio | | Injection | Injection | Injection | |
|  | Type | | Liquid | Liquid | Liquid | |
| | Axial Fan Belt Adjustment | Deflection | mm (in) | N.A. | N.A. | N.A. |
| | | Force | kg (lbf) | N.A. | N.A. | N.A. |
| | Thermostat Opening Temperature | °C (°F) | 42 (108) | 42 (108) | 42 (108) | |
| Radiator Cap Opening Pressure | kPa (PSI) | 90 (13) | 90 (13) | 90 (13) | | |
|  | ENGINE COLD N _m (lb-ft) | Drive Pulley Retaining Screw | ⑦ | ⑦ | ⑦ | |
| | | Exhaust Manifold Nuts or Bolts | 22 (16) | 22 (16) | 22 (16) | |
| | | Magneto Ring Nut | 125 (92) | 125 (92) | 125 (92) | |
| | | Crankcase Nuts or Screws | M6 | 9 (7) | 9 (7) | 9 (7) |
| | | | M8 | 29 (21) | 29 (21) | 29 (21) |
| | | Crankcase/Engine Support Nuts or Screws | 35 (26) | 35 (26) | 9 (7) 29 (21) | |
| | | Cylinder Head Screws | 29 (21) | 29 (21) | 29 (21) | |
| | | Crankcase/Cylinder Nuts or Screws | 29 (21) | 29 (21) | 40 (29) | |
| Axial Fan Shaft Nut | N.A. | N.A. | N.A. | | | |

SECTION 02 - 2004 MODELS TECHNICAL DATA





| VEHICLE MODEL | | SUMMIT 600 HO/R/ ADRENALINE/X (CAN./U.S.) | SUMMIT 800 HO /R/ HIGHMARK/X/Xtreme (CAN./U.S.) | SUMMIT 800 HO /R/ SPORT (CAN./U.S.) | |
|---|--|---|---|---|---|
| ENGINE TYPE | | 593 | 793 | 793 | |
|  | Number of Cylinders | 2 | 2 | 2 | |
| | Bore | mm (in) | 72.00 (2.835) | 82.0 (3.228) | 82.00 (32.228) |
| | Stroke | mm (in) | 73.0 (2.874) | 75.70 (2.980) | 75.70 (2.980) |
| | Displacement | cm ³ (in ³) | 594.40 (36.27) | 799.20 (48.77) | 799.20 (48.77) |
| | Compression Ratio | | 12.3 ± 0.5 | 13.25 ± 0.25 | 13.25 ± 0.25 |
| | Maximum Power Engine Speed ① | ± 100 RPM | 8000 | 7850 | 7850 |
| | Piston Ring Type | 1 st /2 nd | ST/N.A. | ST/N.A. | ST/N.A. |
| | Ring End Gap | New Wear Limit | mm (in) mm (in) | 0.4 (.016) 1.0 (.039) | 0.4 (.016) 1.0 (.039) |
| | Ring/Piston Groove Clearance | New Wear Limit | mm (in) mm (in) | 0.05 (.0020) 0.2 (.0079) | 0.05 (.0020) 0.2 (.0079) |
| | Piston/Cylinder Wall Clearance | New Wear Limit | mm (in) mm (in) | 0.105 ± 0.013 (.0041 ± .0005) 0.20 (.0079) | 0.125 ± 0.023 (.0049 ± .0009) 0.20 (.0079) |
| | Connecting Rod Big End Axial Play | New Wear Limit | mm (in) mm (in) | 0.310 (.0122) 1.2 (.0472) | 0.39 (.0154) 1.2 (.0472) |
| | Maximum Crankshaft End-play ② | | mm (in) | 0.3 (.012) | 0.3 (.012) |
| | Maximum Crankshaft Deflection at PTO | | mm (in) | 0.06 (.0024) | 0.06 (.0024) |
| |  | Magneto Generator Output | W | 360 | 360 |
| Ignition Type | | | CDI | CDI | CDI |
| Spark Plug Make and Type | | | NGK BR9ECS | NGK BR9ECS | NGK BR9ECS |
| Spark Plug Gap | | ± 0.05 mm (± .002 in) | N.A.⑧ | N.A.⑧ | N.A.⑧ |
| Ignition Timing BTDC ③ | | mm (in) | 2.79 (.110) | 2.37 (.093) | 2.37 (.093) |
| Trigger Coil ④ | | | Ω | 190 – 300 | 190 – 300 |
| Generating Coil ④ | | Low Speed High Speed | Ω | N.A. N.A. | N.A. N.A. |
| Lighting Coil ④ | | | Ω | 0.1 – 1.0 | 0.1 – 1.0 |
| High Tension Coil ④ | | Primary Secondary | Ω kΩ | N.A. N.A. | N.A. N.A. |
|  | | Carburetor Type | PTO/MAG | TM 40-B298 | TM 40-B295 |
| | Main Jet | PTO/MAG | 380/380 | 430/430 | 380/380 |
| | Needle Jet | | P-0 ⑤ | P-0 ⑤ | P-0 ⑤ |
| | Pilot Jet | | 17.5 | 17.5 | 17.5 |
| | Needle Identification — Clip Position | PTO/MAG | 9DGK11-58 ⑥ | 9EGY2-58 ⑥ | 9DGI13-58 ⑥ |
| | Slide Cut-Away | | 2.0 | 2.0 | 2.0 |
| | Float Adjustment | ± 1 mm (± .040 in) | N.A. | N.A. | N.A. |
| | Air or Pilot Screw Adjustment | ± 1/16 turn | 1-1/2 | 1-1/2 | 1.5 |
| | Idle Speed | ± 200 RPM | 1600 | 1500 | 1500 |
| | Gas Type/Pump Octane Number | | Unleaded/87 | Unleaded/87 | Unleaded/87 |
| | Gas/Oil Ratio | | Injection | Injection | Injection |
|  | Type | | Liquid | Liquid | Liquid |
| | Axial Fan Belt Adjustment | Deflection Force | mm (in) kg (lbf) | N.A. N.A. | N.A. N.A. |
| | Thermostat Opening Temperature | | °C (°F) | 42 (108) | 42 (108) |
| | Radiator Cap Opening Pressure | | kPa (PSI) | 90 (13) | 90 (13) |
|  | ENGINE COLD N·m (lb·ft) | | | | |
| | Drive Pulley Retaining Screw | | ⑦ | ⑦ | ⑦ |
| | Exhaust Manifold Nuts or Bolts | | 22 (16) | 22 (16) | 22 (16) |
| | Magneto Ring Nut | | 125 (92) | 125 (92) | 125 (92) |
| | Crankcase Nuts or Screws | M6 M8 | 9 (7) 29 (21) | 9 (7) 29 (21) | 9 (7) 29 (21) |
| | Crankcase/Engine Support Nuts or Screws | | 35 (26) | 35 (26) | 35 (26) |
| | Cylinder Head Screws | | 29 (21) | 29 (21) | 29 (21) |
| | Crankcase/Cylinder Nuts or Screws | | 29 (21) | 40 (29) | 40 (29) |
| Axial Fan Shaft Nut | | N.A. | N.A. | N.A. | |

SECTION 02 - 2004 MODELS TECHNICAL DATA

VEHICLE

| VEHICLE MODEL | | MX Z X 440 RACING (CAN./U.S.) | MX Z 600 HO R/X/ ADRENALINE(CAN./ U.S.) | MX Z 600 HO E/R (CAN./ U.S.) |
|--|--|----------------------------------|---|---------------------------------------|
| ENGINE TYPE | | 453 | 593 | 593 |
| Chain Drive Ratio | | 21/43 | 22/43 | 22/43 |
| Chain | Pitch mm (in) | 9.525 (.375) | 9.525 (.375) | 9.525 (.375) |
| | Type/Links Qty/Plates Qty | Silent 74 - 15 | Silent 74/13 | Silent 74/13 |
| Drive Pulley | Type of Drive Pulley | TRA | TRA III | TRA III |
| | Ramp Identification and Roller Pin Type | 296 ④ | 410 ④ | 410 ④ |
| | Calibration Screw Position or Calibration Part | 5 | 3 | 3 |
| | Spring Color | Blue | Violet/Blue | Violet/Blue |
| | Spring Length mm (in) | 120 (4.72) | 114.60 (4.512) | 114.60 (4.512) |
| | Clutch Engagement ± 100 RPM | 5000 | 3800 | 3800 |
| Driven Pulley | Type | FORMULA | HPV27 VSA | HPV27 VSA |
| | Spring Preload ± 0.7 kg (± 1.5 lb) | 7.0 (154) | N.A. | N.A. |
| | Cam Angle Degree | 53/47 | 47/44 | 47/44 |
| Pulley Distance | Z ± 0.5 mm (± .020 in) | 17.5 (.689) | 20 (.787) | 20 (.787) |
| | X ± 0.5 mm (± .020 in) | 35.5 (1-25/64) | 37 (1.457) | 37 (1.457) |
| Offset | Y - X | | | |
| | MIN. - MAX. mm (in) | 1.5 (0.059) | 1.5 ± 0.75 (.059 ± .030) | 1.5 ± 0.75 (.059 ± .030) |
| Drive Belt Part Number (P/N) | | 417 300 253 | 417 300 197 | 417 300 197 |
| Drive Belt Width (wear limit) mm (in) | | 34.7 (1-3/8) | 33.4 (1.31) | 33.4 (1.31) |
| Drive Belt Adjustment | Deflection ± 5 mm (± .197 in) | 32 (1.260) | 32 (1.260) | 32 (1.260) |
| | Force ② kg (lbf) | 11.3 (25) | 11.3 (25) | 11.3 (25) |
| Track | Width mm (in) | 381 (15.0) | 381 (15.0) | 381 (15.0) |
| | Length mm (in) | 3074 (121) | 3074 (121) | 3074 (121) |
| | Profile Height mm (in) | 41.3 (1.625) | STD: 25.4 (1.000) OPT: 31.8 (1.25) | STD: 25.4 (1.000) OPT: 31.8 (1.25) |
| | Adjustment | Deflection mm (in) | 30 - 35 (1-11/64 - 1-3/8) | 30 - 35 (1-3/16 - 1-3/8) |
| Force ③ kg (lbf) | | 7.3 (16) | 7.3 (16) | 7.3 (16) |
| Suspension Type | Track | SC10 III | SC-10 III | SC-10 III |
| | Ski | R.A.S. A-Arm | R.A.S. A-Arm | R.A.S. A-Arm |
|  | Length mm (in) | 278.7(109.7) | 2787 (109.7) | 2787 (109.7) |
| | Width mm (in) | 121.7 (47.9) | 1217 (47.9) | 1217 (47.9) |
| | Height mm (in) | 1280 (50.4) | 1280 (50.4) | 1280 (50.4) |
| | Ski Stance (carbide to carbide) mm (in) | 1080 (42.5) | 1195 (47.0) | 1195 (47.0) |
| | Mass (dry) kg (lb) | 199 (438) | 211 (464) | 223 (491) |
| | Ground Contact Area cm² (in²) | 6670 (1034) | 6910.2 (1071.9) | 6910.2 (1071.9) |
| | Ground Contact Pressure kPa (PSI) | 2.93 (.425) | 3.00 (.435) | 3.17 (.460) |
| | Frame Material | Aluminum | Aluminum | Aluminum |
| | Bottom Pan Material | Impact copolymer | Impact copolymer | Impact copolymer |
| | Hood Material | Surlyn | Surlyn | Surlyn |
|  | Battery V/A•h | N.A. | N.A. | 12/18 |
| | Headlamp W | H4 60/55 | H4 60/55 | H4 60/55 |
| | Taillight and Stoplight W | 8/27 | 8/27 | 8/27 |
| | Tachometer and Speedometer Bulbs W | 2 x 3 | 2 x 3 | 2 x 3 |
| | Fuel and Temperature Gauge Bulbs W | N.A. | N.A. | N.A. |
| | Fuse | Starter Solenoid A | N.A. | N.A. |
| Fuel Level Sensor A | | N.A. | N.A. | .25 |
|  | Fuel Tank L (U.S. gal) | 21 (5.5) | 36 (9.5) | 36 (9.5) |
| | Chaincase/Gearbox mL (U.S. oz) | 250 (8.5) | 250 (8.5) | 250 (8.5) |
| | Cooling System ① L (U.S. oz) | 4.3 (145.4) | 4.7(158.9) | 4.7(158.9) |
| | Injection Oil Reservoir L (U.S. oz) | N.A. | 3.5 (118.4) | 3.5 (118.4) |



SECTION 02 - 2004 MODELS TECHNICAL DATA

| VEHICLE MODEL | | MX Z 600 E/R/ RENEGADE/X (CAN./U.S.) | MX Z 800 HO R/X/ ADRENALINE(CAN./ U.S.) | MX Z 800 E/R/ RENEGADE/X (CAN./U.S.) | | | |
|---|----------------------------------|--|---|--|---------------------------------------|---------------------------------------|---------------------------------------|
| ENGINE TYPE | | 593 | 793 | 793 | | | |
|  | Chain Drive Ratio | | 22/43 | 26/45 | 23/43 | | |
| | Chain | Pitch | mm (in) | 9.525 (.375) | 9.525 (.375) | 9.525 (.375) | |
| | | Type/Links Qty/Plates Qty | | Silent 74/13 | Silent 76/13 | Silent 74/13 | |
| | Drive Pulley | Type of Drive Pulley | | TRA III | TRA III | TRA III | |
| | | Ramp Identification and Roller Pin Type | | 410 ④ | 414 ④ | 413 ④ | |
| | | Calibration Screw Position or Calibration Part | | 3 | 3 | 3 | |
| | | Spring Color | | Violet/Blue | Violet/Green | Violet/Green | |
| | | Spring Length | | mm (in) | 114.60 (4.512) | 133.5(5.256) | 133.5(5.256) |
| | | Clutch Engagement | | ± 100 RPM | 3800 | 3800 | 3800 |
| | Driven Pulley | Type | | HPV27 VSA | HPV27 | HPV27 | |
| | | Spring Preload | | ± 0.7 kg (± 1.5 lb) | N.A. | N.A. | N.A. |
| | | Cam Angle | | Degree | 47/44 | 50/40 | 47/40 |
| | Pulley Distance | Z | | ± 0.5 mm (± .020 in) | 20 (.787) | 20 (.787) | 17.5 (.689) |
| | Offset | X | | ± 0.5 mm (± .020 in) | 37 (1.457) | 37 (1.457) | 35.5 (1.398) |
| | | Y - X | MIN. - MAX. | mm (in) | 1.5 ± 0.75 (.059 ± .030) | 1.5 ± 0.75 (.059 ± .030) | 1.5 ± 0.75 (.059 ± .030) |
| | Drive Belt Part Number (P/N) | | | 417 300 197 | 417 300 166 | 417 300 166 | |
| | Drive Belt Width (wear limit) | | | mm (in) | 33.4 (1.31) | 34.7 (1.366) | 34.7 (1.366) |
| | Drive Belt Adjustment | Deflection | | ± 5 mm (± .197 in) | 32 (1.260) | 32 (1.260) | 32 (1.260) |
| | | Force ② | | kg (lbf) | 11.3 (25) | 11.3 (25) | 11.3 (25) |
| | Track | Width | | mm (in) | 381 (15.0) | 381 (15.0) | 381 (15.0) |
| | | Length | | mm (in) | 3455 (136) | 3074 (121) | 3074 (121) |
| | | Profile Height | | mm (in) | STD: 25.4 (1.000) OPT: 31.8 (1.25) | STD: 25.4 (1.000) OPT: 31.8 (1.25) | STD: 25.4 (1.000) OPT: 31.8 (1.25) |
| | | Adjustment | Deflection | | mm (in) | 30 - 35 (1-3/16 - 1-3/8) | 30 - 35 (1-3/16 - 1-3/8) |
| Force ③ | | | kg (lbf) | 7.3 (16) | 7.3 (16) | 7.3 (16) | |
| Suspension Type | | Track | SC-10 III | SC-10 III | SC-10 III | | |
| | | Ski | R.A.S. A-Arm | R.A.S. A-Arm | R.A.S. A-Arm | | |
|  | Length | | mm (in) | 3005 (118.31) | 2787 (109.7) | 3005 (118.31) | |
| | Width | | mm (in) | 1172 (46.14) | 1217 (47.9) | 1172 (46.14) | |
| | Height | | mm (in) | 1130 (44.49) | 1280 (50.4) | 1130 (44.49) | |
| | Ski Stance (carbide to carbide) | | mm (in) | 1195 (47.0) | 1195 (47.0) | 1195 (47.0) | |
| | Mass (dry) | | kg (lb) | 218 (480) | 211 (464) | 230 (506) | |
| | Ground Contact Area | | cm² (in²) | 7596 (1177.4) | 6910.2 (1071.9) | 7596 (1177.4) | |
| | Ground Contact Pressure | | kPa (PSI) | 2.82 (.41) | 3.00 (.435) | 2.97 (.431) | |
| | Frame Material | | | Aluminum | Aluminum | Aluminum | |
| | Bottom Pan Material | | | Impact copolymer | Impact copolymer | Impact copolymer | |
| | Hood Material | | | Surlyn | Surlyn | Surlyn | |
|  | Battery | | V/A•h | 12/18 | N.A. | 12/18 | |
| | Headlamp | | W | H4 60/55 | H4 60/55 | H4 60/55 | |
| | Taillight and Stoplight | | W | 8/27 | 8/27 | 8/27 | |
| | Tachometer and Speedometer Bulbs | | W | 2 x 3 | 2 x 3 | 2 x 3 | |
| | Fuel and Temperature Gauge Bulbs | | W | N.A. | N.A. | N.A. | |
| | Fuse | Starter Solenoid | | A | 30 | N.A. | 30 |
| | | Fuel Level Sensor | | A | .25 | N.A. | .25 |
|  | Fuel Tank | | L (U.S. gal) | 36 (9.5) | 36 (9.5) | 36 (9.5) | |
| | Chaincase/Gearbox | | mL (U.S. oz) | 250 (8.5) | 250 (8.5) | 250 (8.5) | |
| | Cooling System ① | | L (U.S. oz) | 4.8(162.3) | 4.7(158.9) | 4.8(162.3) | |
| | Injection Oil Reservoir | | L (U.S. oz) | 3.5 (118.4) | 3.5 (118.4) | 3.5 (118.4) | |

SECTION 02 - 2004 MODELS TECHNICAL DATA

| VEHICLE MODEL | | SUMMIT 600 HO R/X/ ADRENALINE (CAN./U.S.) | SUMMIT 800 HO R/X/ ADRENALINE (CAN./U.S.) | SUMMIT 800 HO R HIGHMARK (CAN./U.S.) | |
|----------------------------------|--|---|---|--|--------------------------|
| ENGINE TYPE | | 593 | 793 | 793 | |
| Chain Drive Ratio | | 19/45 | 19/45 | 19/43 | |
| Chain | Pitch | mm (in) 9.525 (.375) | 9.525 (.375) | 9.525 (.375) | |
| | Type/Links Qty/Plates Qty | Silent 74/13 | Silent 74/13 | Silent 72/13 | |
| Drive Pulley | Type of Drive Pulley | TRA III | TRA III | TRA III | |
| | Ramp Identification and Roller Pin Type | 417 ④ | 415 ④ | 415 ④ | |
| | Calibration Screw Position or Calibration Part | 3 | 3 | 3 | |
| | Spring Color | Violet/White | Violet/Yellow | Violet/Yellow | |
| | Spring Length | mm (in) 98.5 (3.878) | 157.9 (6.217) | 157.9 (6.217) | |
| | Clutch Engagement | ± 100 RPM 3600 | 3800 | 3800 | |
| Driven Pulley | Type | HPV27 | HPV27 | HPV27 | |
| | Spring Preload | ± 0.7 kg (± 1.5 lb) N.A. | N.A. | N.A. | |
| | Cam Angle | Degree 47/44 | 44 | 44/40 | |
| Pulley Distance | Z ± 0.5 mm (± .020 in) | 20 (.787) | 20 (.787) | 20 (.787) | |
| Offset | X ± 0.5 mm (± .020 in) | 37 (1.457) | 37 (1.457) | 37 (1.457) | |
| | Y - X MIN. - MAX. | mm (in) 1.5 ± 0.75 (.059 ± .030) | 1.5 ± 0.75 (.059 ± .030) | 1.5 ± 0.75 (.059 ± .030) | |
| Drive Belt Part Number (P/N) | | 417 300 197 | 417 300 166 | 417 300 166 | |
| Drive Belt Width (wear limit) | | mm (in) 34.7 (1.366) | 34.7 (1.366) | 34.7 (1.366) | |
| Drive Belt Adjustment | Deflection | ± 5 mm (± .197 in) 32 (1.260) | 32 (1.260) | 32 (1.260) | |
| | Force ② | kg (lbf) 11.3 (25) | 11.3 (25) | 11.3 (25) | |
| Track | Width | mm (in) 406 (15.98) | 406 (15.98) | 406 (15.98) | |
| | Length | mm (in) 3648 (143.62) | 3648 (143.62) | 3836 (151) | |
| | Profile Height | mm (in) 50.8 | 50.8 | 50.8 | |
| | Adjustment | Deflection | mm (in) 30 - 35 (1-3/16 - 1-3/8) | 30 - 35 (1-3/16 - 1-3/8) | 30 - 35 (1-3/16 - 1-3/8) |
| | | Force ③ | kg (lbf) 7.3 (16) | 7.3 (16) | 7.3 (16) |
| Suspension Type | Track | SC-10 144 | SC-10 159 | SC-10 151 | |
| | Ski | R.A.S. A-Arm | R.A.S. A-Arm | R.A.S. A-Arm | |
| Length | | mm (in) 3134 (123.4) | 3134 (123.4) | 3216 (126.614) | |
| Width | | mm (in) 1139 (44.8) | 1139 (44.8) | 1139 (44.8) | |
| Height | | mm (in) 1130 (44) | 1130 (44) | 1130 (44) | |
| Ski Stance (carbide to carbide) | | mm (in) 1029 (40.5) | 1029 (40.5) | 1029 (40.5) | |
| Mass (dry) | | kg (lb) 218 (480) | 218 (480) | 223 (491) | |
| Ground Contact Area | | cm ² (in ²) 9044.1 (1401.84) | 9044.1 (1401.84) | 9531.3 (1477.354) | |
| Ground Contact Pressure | | kPa (PSI) 2.36 (.342) | 2.36 (.342) | 2.30 (.334) | |
| Frame Material | | Aluminum | Aluminum | Aluminum | |
| Bottom Pan Material | | Impact copolymer | Impact copolymer | Impact copolymer | |
| Hood Material | | Surlyn | Surlyn | Surlyn | |
| Battery | | V/A•h N.A. | N.A. | N.A. | |
| Headlamp | | W H4 60/55 | H4 60/55 | H4 60/55 | |
| Taillight and Stoplight | | W 8/27 | 8/27 | 8/27 | |
| Tachometer and Speedometer Bulbs | | W 2 x 3 | 2 x 3 | 2 x 3 | |
| Fuel and Temperature Gauge Bulbs | | W N.A. | N.A. | N.A. | |
| Fuse | Starter Solenoid | A N.A. | N.A. | N.A. | |
| | Fuel Level Sensor | A N.A. | N.A. | N.A. | |
| Fuel Tank | | L (U.S. gal) 36 (9.5) | 36 (9.5) | 36 (9.5) | |
| Chaincase/Gearbox | | mL (U.S. oz) 250 (8.5) | 250 (8.5) | 250 (8.5) | |
| Cooling System ① | | L (U.S. oz) 4.9 (165.7) | 4.9 (165.7) | 5.0 (169.1) | |
| Injection Oil Reservoir | | L (U.S. oz) 3.5 (118.4) | 3.5 (118.4) | 3.5 (118.4) | |

SECTION 02 - 2004 MODELS TECHNICAL DATA

| VEHICLE MODEL | | SUMMIT 800 HO R HIGHMARK X (CAN./U.S.) | SUMMIT 800 HO R HIGHMARK Xtreme (CAN./U.S.) | SUMMIT 800 HO R SPORT (CAN./U.S.) | |
|---|--|--|---|---|--------------------------|
| ENGINE TYPE | | 793 | 793 | 793 | |
| Chain Drive Ratio | | 19/43 | 19/43 | 19/43 | |
| Chain | Pitch | 9.525 (.375) mm (in) | 9.525 (.375) | 9.525 (.375) | |
| | Type/Links Qty/Plates Qty | Silent 72/13 | Silent 72/13 | Silent 72/13 | |
| Drive Pulley | Type of Drive Pulley | TRA III | TRA III | TRA III | |
| | Ramp Identification and Roller Pin Type | 415 ④ | 415 ④ | 415 ④ | |
| | Calibration Screw Position or Calibration Part | 3 | 3 | 3 | |
| | Spring Color | Violet/Yellow | Violet/Yellow | Violet/Yellow | |
| | Spring Length | 157.9 (6.217) mm (in) | 157.9 (6.217) | 157.9 (6.217) | |
| | Clutch Engagement | ± 100 RPM | 3800 | 3800 | |
| Driven Pulley | Type | HPV27 | HPV27 | HPV27 | |
| | Spring Preload | ± 0.7 kg (± 1.5 lb) | N.A. | N.A. | |
| | Cam Angle | Degree | 44/40 | 44/40 | |
| Pulley Distance | Z | ± 0.5 mm (± .020 in) | 20 (.787) | 20 (.787) | |
| Offset | X | ± 0.5 mm (± .020 in) | 37 (1.457) | 37 (1.457) | |
| | Y - X | MIN. - MAX. | 1.5 ± 0.75 (.059 ± .030) mm (in) | 1.5 ± 0.75 (.059 ± .030) | |
| Drive Belt Part Number (P/N) | | 417 300 166 | 417 300 166 | 417 300 166 | |
| Drive Belt Width (wear limit) | | 34.7 (1.366) mm (in) | 34.7 (1.366) | 34.7 (1.366) | |
| Drive Belt Adjustment | Deflection | ± 5 mm (± .197 in) | 32 (1.260) | 32 (1.260) | |
| | Force ② | kg (lbf) | 11.3 (25) | 11.3 (25) | |
| Track | Width | mm (in) | 406 (15.98) | 406 (15.98) | |
| | Length | mm (in) | 3836 (151) | 4038 (158.97) | |
| | Profile Height | mm (in) | 50.8 | 50.8 | |
| | Adjustment | Deflection | mm (in) | 30 - 35 (1-3/16 - 1-3/8) | 30 - 35 (1-3/16 - 1-3/8) |
| | | Force ③ | kg (lbf) | 7.3 (16) | 7.3 (16) |
| Suspension Type | Track | SC-10 151 | SC-10 159 | SC-10 151 | |
| | Ski | R.A.S. A-Arm | R.A.S. A-Arm | R.A.S. A-Arm | |
|  | Length | mm (in) | 3216 (126.614) | 3134 (123.4) | |
| | Width | mm (in) | 1139 (44.8) | 1139 (44.8) | |
| | Height | mm (in) | 1130 (44) | 1130 (44) | |
| | Ski Stance (carbide to carbide) | mm (in) | 1029 (40.5) | 1029 (40.5) | |
| | Mass (dry) | kg (lb) | 220 (484) | 222 (488) | |
| | Ground Contact Area | cm ² (in ²) | 9531.3 (1477.354) | 10018.5 (1552.87) | |
| | Ground Contact Pressure | kPa (PSI) | 2.26 (.328) | 2.17 (.315) | |
| | Frame Material | | Aluminum | Aluminum | |
| | Bottom Pan Material | | Impact copolymer | Impact copolymer | |
| | Hood Material | | Surlyn | Surlyn | |
|  | Battery | V/A•h | N.A. | N.A. | |
| | Headlamp | W | H4 60/55 | H4 60/55 | |
| | Taillight and Stoplight | W | 8/27 | 8/27 | |
| | Tachometer and Speedometer Bulbs | W | 2 x 3 | 2 x 3 | |
| | Fuel and Temperature Gauge Bulbs | W | N.A. | N.A. | |
| | Fuse | Starter Solenoid | A | N.A. | N.A. |
| | | Fuel Level Sensor | A | N.A. | N.A. |
|  | Fuel Tank | L (U.S. gal) | 36 (9.5) | 36 (9.5) | |
| | Chaincase/Gearbox | mL (U.S. oz) | 250 (8.5) | 250 (8.5) | |
| | Cooling System ① | L (U.S. oz) | 5.0 (169.1) | 5.2 (175.9) | |
| | Injection Oil Reservoir | L (U.S. oz) | 3.5 (118.4) | 3.5 (118.4) | |

SECTION 02 - 2004 MODELS TECHNICAL DATA

ENGINE LEGEND

BTDC: Before Top Dead Center

CDI: Capacitor Discharge Ignition

K: Kilo (x 1000)

ST: Semi-Trapezoidal

MAG: Magneto Side

N.A.: Not Applicable

PTO: Power Take Off Side

- ① The maximum horsepower RPM applicable on the vehicle. It may be different under certain circumstances and BOMBARDIER INC. reserves the right to modify it without obligation.
- ② Crankshaft end-play is not adjustable on these models. Specification is given for verification purposes only.
- ③ At 3500 RPM with headlamp turned on.
- ④ All resistance measurements must be performed with parts at room temperature (approx. 20°C (68°F)). Temperature greatly affects resistance measurements.
- ⑤ Press fit type, not replaceable.
- ⑥ Needle with one groove, not adjustable.
- ⑦ Drive pulley retaining screw: torque to 80 to 100 N•m (59 to 74 lbf•ft), install drive belt, accelerate the vehicle at low speed (maximum 30 km/h (20 MPH)) and apply the brake; repeat 5 times. Retorque screw to 90 to 100 N•m (66 to 74 lbf•ft).
- ⑧ **CAUTION: Do not attempt to adjust gap on spark plug BR 9 ECS.**
- ⑨ For vehicle with pre-heat switch enabled, use racing fuel with octane number 108.

VEHICLE LEGEND

RAS: Response Angle Suspension

TRA: Total Range Adjustable

RER: Rotax Electronic Reverse

VSA: Variable Sheave Angle

N.A.: Not Applicable

- ① Coolant mixture: 60% antifreeze/40% water.
- ② Force applied midway between pulleys to obtain specified tension deflection.
- ③ Force or downward pull applied to track to obtain specified tension deflection.
- ④ Lever with roller pin.

TABLE OF CONTENTS

| | |
|---|--------------|
| SUSPENSION OPERATION/ WEIGHT TRANSFER | 03-2 |
| SPRINGS | 03-3 |
| SPRING DESCRIPTION | 03-8 |
| COIL SPRINGS (compression) | 03-8 |
| TORSION SPRINGS..... | 03-9 |
| SPRING APPLICATIONS | 03-10 |
| SPRING SPECIFICATIONS | 03-12 |
| SHOCKS | 03-17 |
| INTERNAL FLOATING PISTON MEASUREMENT | 03-28 |
| 2004 MX Z X 440 HPG C-36 SHOCKS | 03-29 |
| SHOCK REBUILD PROCEDURE | 03-30 |
| SHOCK VALVING | 03-33 |
| SHOCK CALIBRATION WORK SHEET | 03-35 |
| CHASSIS SET-UP..... | 03-36 |
| BRAKES..... | 03-38 |
| ADJUSTING RIDE HEIGHT | 03-39 |
| ADJUSTING RIDE HEIGHT | 03-39 |
| TRACK GUIDES | 03-40 |
| SKIS AND RUNNERS | 03-40 |
| BUMP STEER | 03-41 |
| SKI LEG CAMBER | 03-41 |
| SKI TOE-OUT | 03-42 |
| CHASSIS TUNING GUIDELINES | 03-43 |

SECTION 03 - CHASSIS PREPARATION

SUSPENSION OPERATION/ WEIGHT TRANSFER

The purpose of any suspension system is to isolate the rider from the terrain while still allowing for complete control of the vehicle. A snowmobile rear suspension has the added requirements of providing weight transfer and maintaining correct track tension.

Weight transfer is essentially the shifting of weight to the track for better traction during acceleration, and to the skis for positive handling during cornering.

The physics that apply to all rear suspensions are basically the same. As we apply torque from the engine to the drive axle, the torque is transferred to the track and pulls it forward. That energy enters the suspension system at the rear axle and tries to pull it forward (force "C" in following illustration). The rear arm is a pivoting or sliding linkage that only provides vertical forces at the rear of the chassis, therefore, none of force "C" enters the chassis at the rear arm.

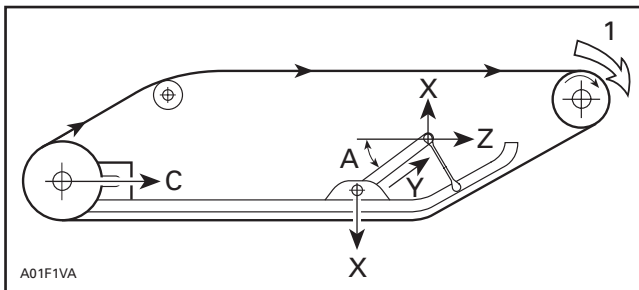

1. Drive axle torque

The front arm is mounted with a pivot to both the runners and the chassis. It is through this arm that the major reaction to the engine torque is applied. As the front arm begins to swivel from the load of force "C", it pushes down on the front of the track (force "X" in illustration). This reduces weight on the skis and applies more weight on the track for better traction. The rest of the force "C" enters the chassis through the front arm and accelerates the vehicle (force "Z").

If we keep force "C" constant, we can then vary the size of the vertical and horizontal forces at the front arm by varying angle "A". As angle "A" is made smaller, force "X" decreases, and force "Z" increases. This reduces the amount of torque reaction and more weight stays on the skis. As angle "A" is increased, force "X" increases. The skis then tend to lift more during acceleration and more weight is placed on the track.

We can vary angle "A", within limits, by adjusting the length of the limiter strap. The limiter strap is just that, a strap to limit the extension of the front of the suspension. Shortening the strap decreases angle "A" and is what we would do to set up a machine for more ski pressure. For more track pressure we would want to lengthen the strap to increase angle "A". The limiter adjustment has the largest affect on controlling the amount of weight transfer.

NOTE: Track tension must be checked whenever a major change is made to the limiter length.

Front arm spring pressure will also affect weight transfer. A stiffer spring and/or more preload will transfer more weight to the track. A softer spring and/or less preload will keep more weight on the skis. Springs must also be selected to provide absorption to the intended size of bumps to be encountered. A soft spring will increase ski pressure but may **bottom out** on large bumps, while a stiff spring will provide more track pressure but may produce a harsh ride.

NOTE: In this and other Ski-Doo texts, we refer to the front arm of the rear suspension and it's spring and shock absorber, as the center of the vehicle. The ski suspension is considered the front of the vehicle and the rear arm of the rear suspension and it's spring(s) and shock(s) are indicated as the rear of the vehicle.

Also, think of the center arm as a pivot point. During acceleration the rear arm will want to compress and the front suspension will want to extend (possibly raising the skis off the ground). Because of this **pivoting** affect, the rear spring and preload will also affect weight transfer (to a lesser amount than center arm changes). A softer rear spring and/or less preload will allow more weight transfer to the track and less ski pressure, while stiffer rear springs and/or more preload will allow less weight transfer to the track and more ski pressure.

Contrary to popular belief, it is not necessary to have the skis 2 feet off the ground to achieve good weight transfer. In fact, the energy used to lift the front of the vehicle is not available to push the vehicle forward.

The main function of the rear arm is to support the weight of the vehicle and rider, yet provide usable travel to absorb bumps and jumps. The springs are chosen depending on the linkage design of the rear arm and the intended load to be applied. Stiffer springs will be used on vehicles intended to carry heavier loads and on vehicles that plan to encounter large bumps, while vehicles used for lighter loads and on smaller bumps will use softer springs.

Springs for the front suspension are chosen in a similar fashion. A softer spring will provide less ski pressure and will be used on lighter vehicles while stiffer springs will provide more ski pressure and be used on heavier vehicles.

NOTE: Shock absorber valving and the type of shock used will also affect weight transfer. Refer to the shock absorber section for details.

A.C.M.

The SC-10 High Performance Rear Suspensions incorporates the use of A.C.M. technology. Under hard acceleration, the A.C.M. linkage couples the front and rear arms moving the rails rearward, thus reducing ski lift. The A.C.M. can be used to increase and decrease weight transfer. Tightening the A.C.M. will decrease weight transfer. Loosening the A.C.M. will increase weight transfer.

SPRINGS

General

Generally, 2 types of springs are used on our suspensions. Coil springs and torsional springs. Refer to following illustration.

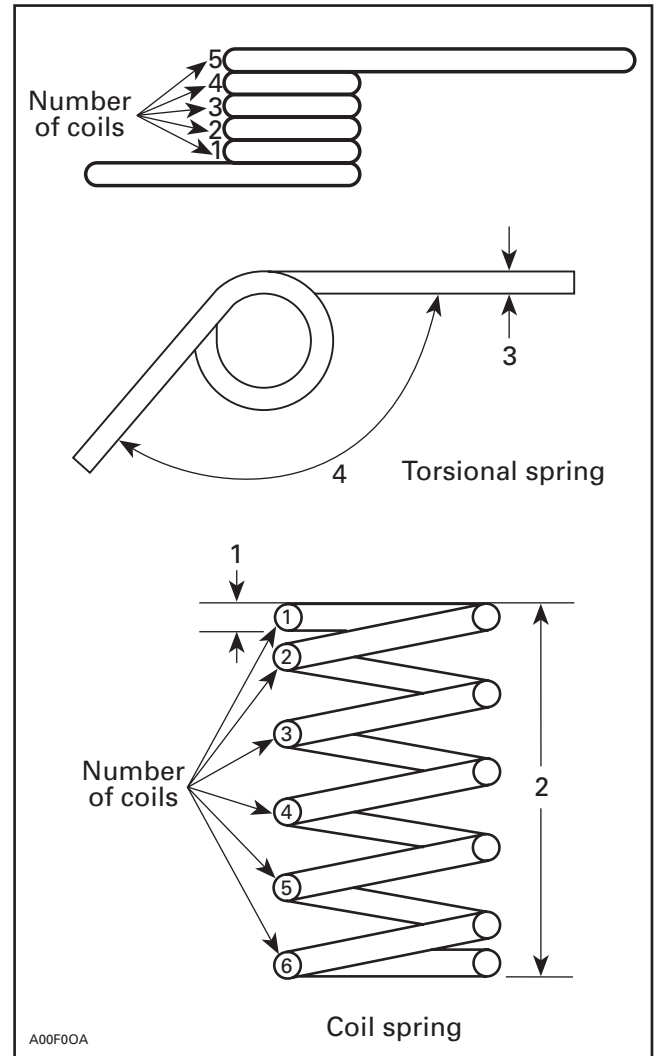

- 1. Wire diameter
- 2. Free length
- 3. Wire diameter
- 4. Opening angle

Several factors are used to determine the characteristics of a spring and they are similar for both the coil and torsional spring types. Wire diameter, material type, the number of coils and the physical shape of a spring all determine how a spring will act. Once these characteristics are built into a spring, they determine the spring rate and the free length in a coil spring or the opening angle and spring rate in a torsional spring.

SECTION 03 - CHASSIS PREPARATION

Coil Springs

The free length of a coil spring is the length with no load applied to the spring.

The spring rate of a coil spring is defined as the amount of force required to compress the spring one inch. If a 100 pound force compresses a spring 1 inch it is referred to as having a rate of 100 lbf/in (pounds per inch). If 150 pounds of force is required to compress a spring 1 inch then it would have a rate of 150 lbf/in (see following illustration).

Most springs are designed as a straight rate spring. This means that the spring requires the same force to compress the last one inch of travel as the first one inch of travel. Example: A 100 lbf/in rate spring will compress one inch for every 100 pounds applied. A force of 200 pounds will compress the spring 2 inches. A 300 pound force will compress the spring 3 inches and so on. The 150 lbf/in rate spring will require 150 pounds to compress the spring each one inch. To compress this spring 3 inches it will require a force of 450 pounds (see following illustration).

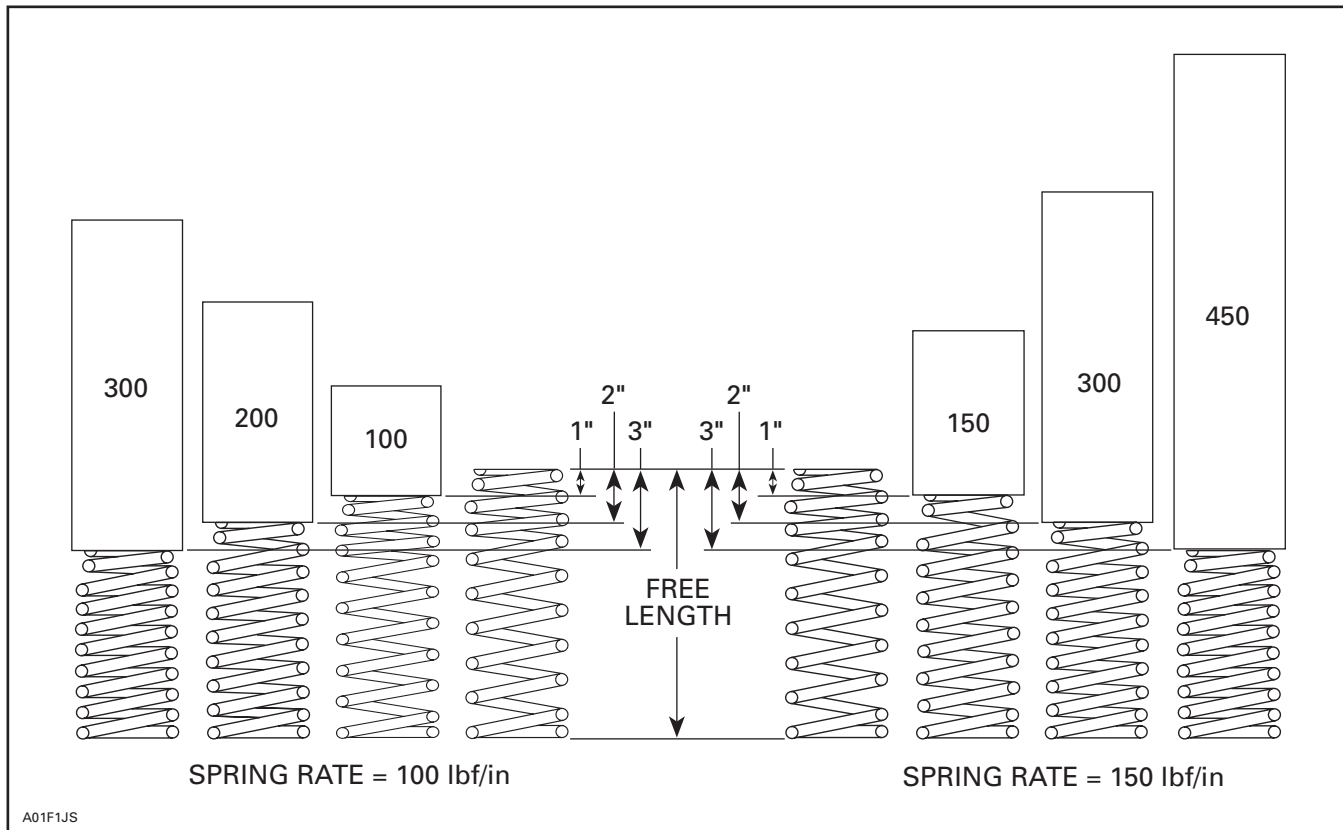
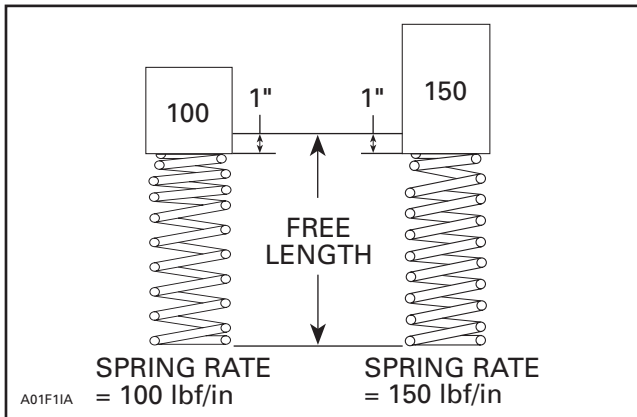

In terms of your suspension, if a bump is encountered that translates into a force at the spring of 450 pounds, the 100 lbf/in spring will want to compress 4.5 inches while the 150 lbf/in spring will only compress 3 inches. If our suspension only has 4 inches of spring travel the unit with the 100 lbf/in spring will bottom out while the 150 lbf/in unit still has 1 inch of travel remaining (see following illustration).

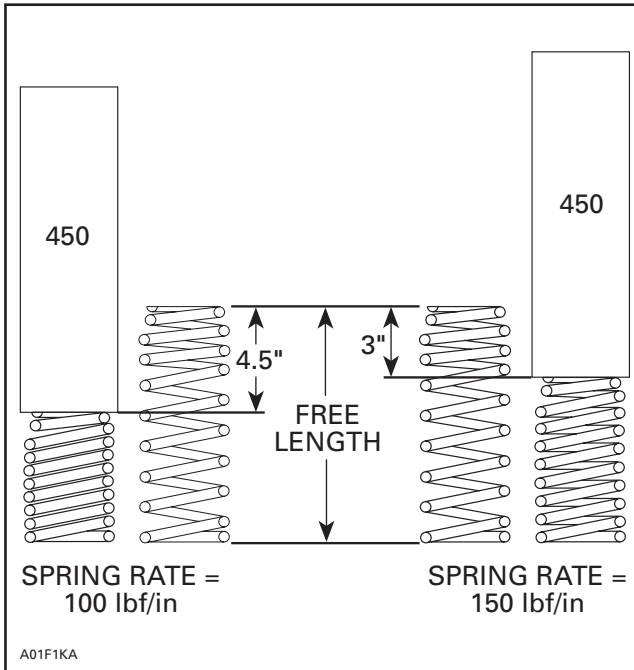

A spring can also be progressively wound. This means that the rate of the spring is increasing as it is compressed. A 100/200 lbf/in progressive spring will require 100 pounds to compress the first one inch but will require 200 additional pounds to compress the last one inch (see following illustration).

SECTION 03 - CHASSIS PREPARATION

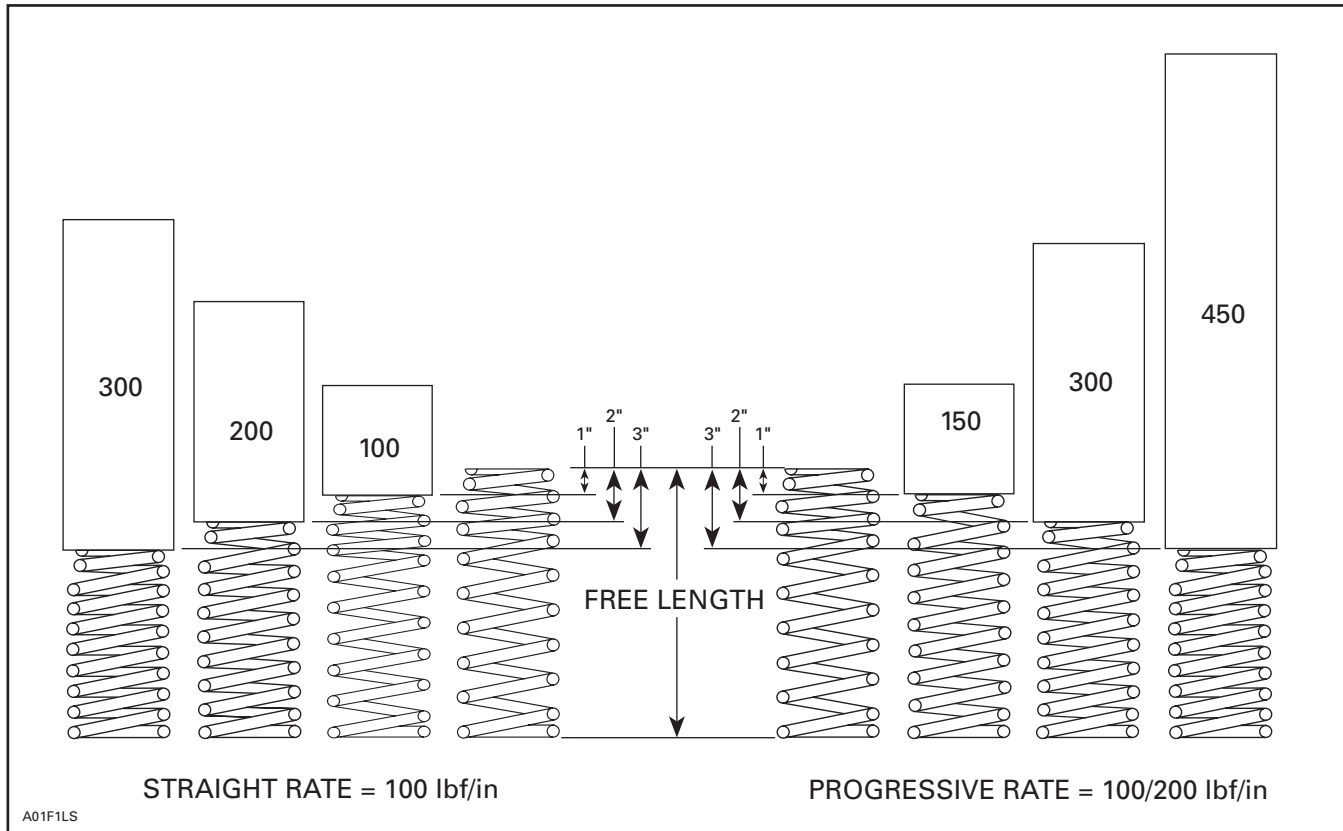

An easy way to measure coil springs is to put a bathroom scale in a press with the spring resting on the scale. Measure the free length and then apply a load until the spring compresses 1 inch. The reading on the scale will approximate the rate of the spring. Now compress the spring another 1 inch. If the spring is a straight rate, the scale reading should be doubled. If the reading is more than doubled, then you have a progressive spring. If you can compress the spring another 1 inch (3 inches total) (do not exceed maximum scale rating or damage may occur) the reading should be 3 times your first reading. In order to maintain a reasonable cost on springs, the manufacturing tolerances are quite large. A 100 lbf/in rated spring may test anywhere from 80 to 120 lbf/in.

Now, so far we have assumed that the 2 springs in our examples have the same free length and that they are not preloaded at all. In the case of our suspensions, we mount the coil springs on a shock absorber. The shock will have a certain length between the spring retainers which is called the installed length of the spring. If the installed length is less than the free length (as is the case in most applications), then there will be some preloading of the spring.

Dual Rate Spring Formula

$$\frac{\text{Spring 1} \times \text{Spring 2}}{\text{Spring 1} + \text{Spring 2}}$$

A Dual Rate Spring will assume the rate of the heavier rate spring when the lighter spring bottoms or coil binds.

Example:

Spring 1 100# Rate

Spring 2 150# Rate

$$\frac{100 \times 150}{100 + 150} = \frac{1500}{250} = 60$$

Spring 1 was a 100# Rate separately, but when stacked on the 150# spring (spring 2), it now has a 60# rate. As the spring bottoms or coil binds, it will assume the 150# rate of spring 2.

Torsional Springs

A torsional spring acts just like a coil spring but it is shaped differently. It is much more difficult to measure the rate of a torsional spring because of the lengths of the legs and where the load will be applied. The rear torsional springs on the S chassis are rated in lb-ft/degree (pounds-feet per degree of rotation). Suffice it to say that there are stiffer and softer springs for most applications.

The preload on a torsional spring is controlled by the free opening angle and the installed opening angle. If a torsional spring must be **twisted** more to be installed, then it will have more preload (following illustration).

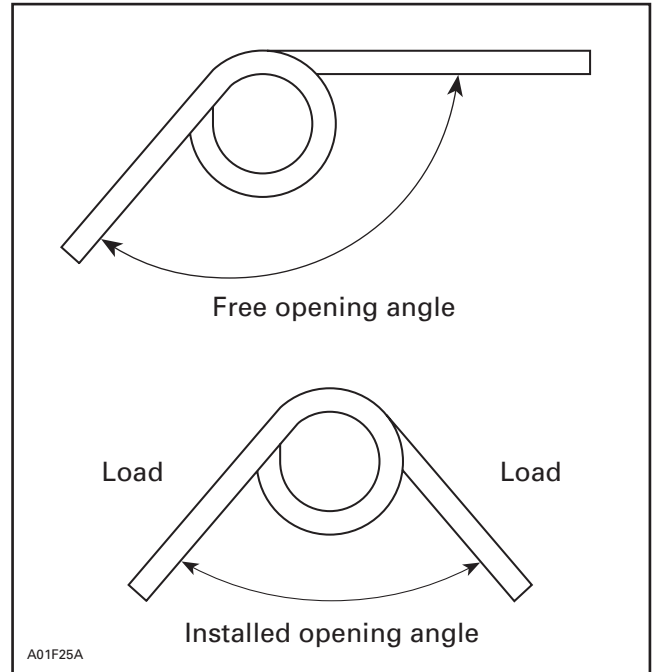

Spring Identification

Our springs will have one, 2 or 3 stripes of color painted on the spring. This is the color code used for identification. Refer to the applicable chart to find a cross reference between the part number, model application, color code, spring rate, free length and spring type. The spring type denotes physical characteristics of the spring like the inside diameter of the ends which will determine the type of retainer used to hold the spring. All spring types are not interchangeable.

CHECK THE SPRING TYPE AND FIT OF THE SPRING RETAINER BEFORE INSTALLING DIFFERENT SPRINGS!

SECTION 03 - CHASSIS PREPARATION

SPRING DESCRIPTION

COIL SPRINGS (compression)

NOTE: Read color when spring is upright and stripes are down.

Type R (straight on both ends)

(Single Rate Spring)

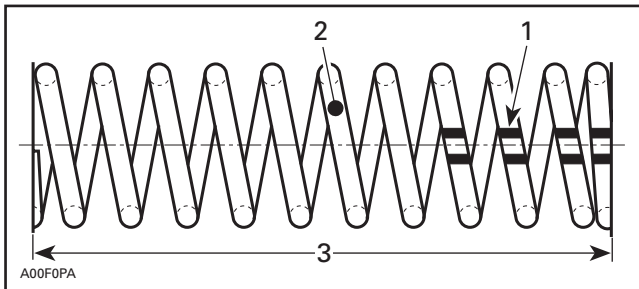

1. Color code stripes
2. Wire diameter
3. Free length

Type S (barrel shape on one end)

(Single Rate Spring)

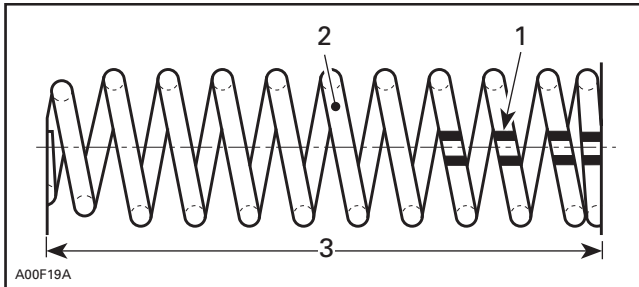

1. Color code stripes
2. Wire diameter
3. Free length

Type T (barrel shape on both ends)

(Single Rate Spring)

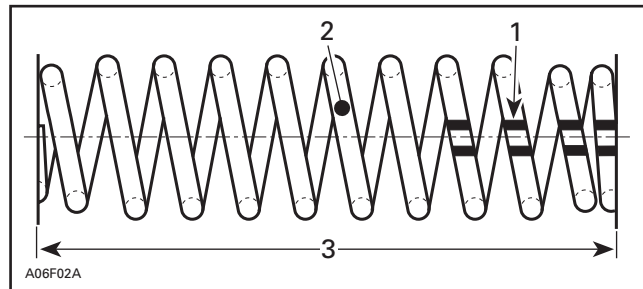

1. Color code stripes
2. Wire diameter
3. Free length

Type U (barrel shape on one end with positioning tab at the other end)

(Single Rate Spring)

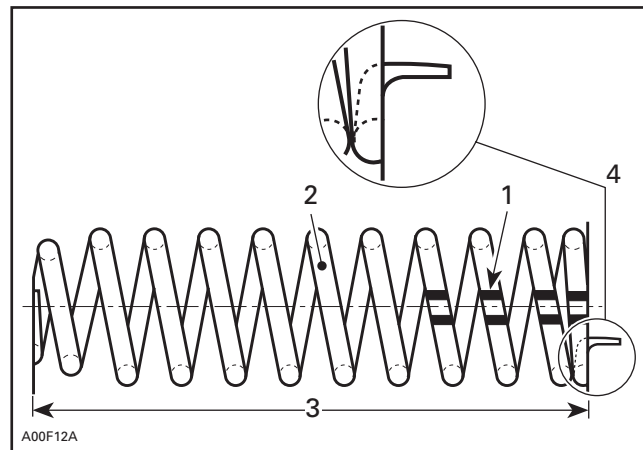

1. Color code stripes
2. Wire diameter
3. Free length
4. Positioning tab

SECTION 03 - CHASSIS PREPARATION

Type Y
(barrel shape on both ends with
positioning tab at the color code coils end)

(Single Rate Spring)

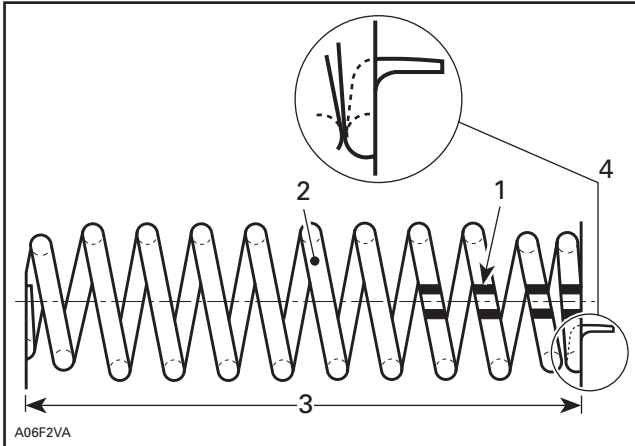

1. Color code stripes
2. Wire diameter
3. Free length
4. Positioning tab

Type 2
(barrel shape on both ends)

(Dual Rate Spring)

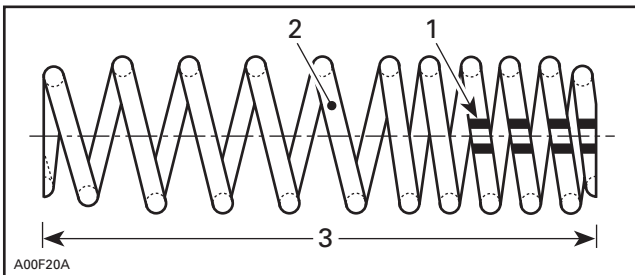

1. Color code stripes
2. Wire diameter
3. Free length

Type 4
(barrel shape on both ends with
positioning tab at the color code coils end)

(Dual Rate Spring)

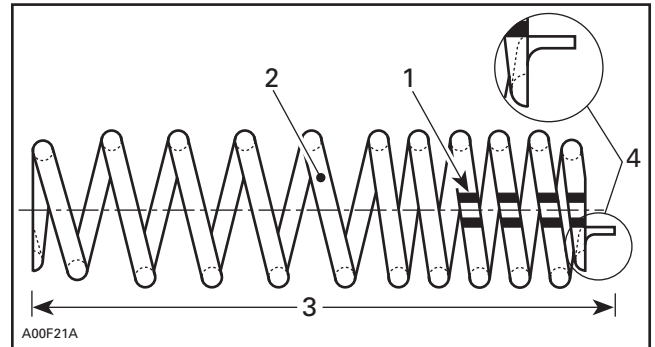

1. Color code stripes
2. Wire diameter
3. Free length
4. Positioning tab

TORSION SPRINGS

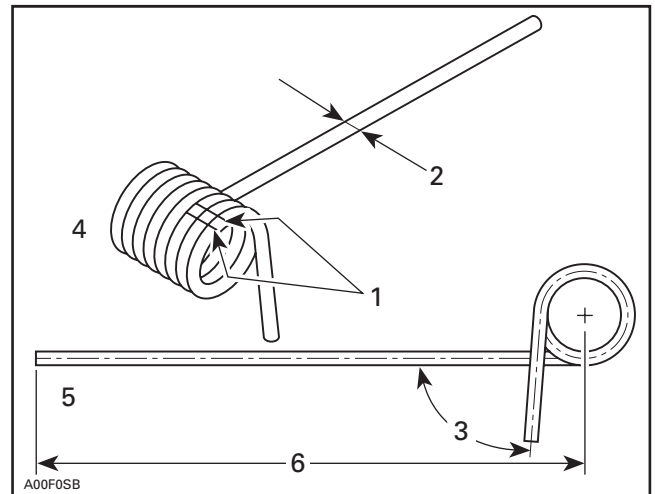

1. Color code stripes
2. Wire diameter
3. Opening angle (°)
4. Left hand (LH)
5. Right hand (RH)
6. Length

SECTION 03 - CHASSIS PREPARATION

SPRING APPLICATIONS

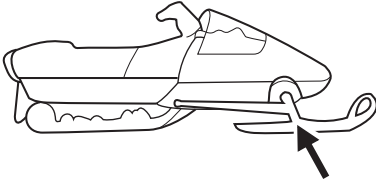
| 2004 | | FRONT SPRINGS | | 2004 | |
|---|---------------------|----------------|---------------------|-------|---------------------|
|  | | | | | |
| MODEL | (P/N) SOFTER SPRING | (P/N) STANDARD | (P/N) HARDER SPRING | MODEL | (P/N) HARDER SPRING |
| MX Z SPORT | 505 070 852 | 505 071 179 | 505 070 153 | | |
| MX Z ADRENALINE | Not Applicable | 505 070 852 | 505 070 153 | | |
| MX Z TRAIL | 505 070 758 | 505 070 393 | 505 070 153 | | |
| MX Zx | 505 070 852 | 505 071 162 | 505 070 153 | | |
| MX Z RENEGADE | Not Applicable | 505 070 758 | 505 070 393 | | |
| MX Z FAN | 505 070 758 | 505 070 393 | 505 070 153 | | |
| SUMMIT SPORT | 505 070 393 | 505 070 762 | 505 070 576 | | |
| SUMMIT X | 505 070 393 | 505 070 760 | 505 070 144 | | |
| SUMMIT HM SPORT | 505 070 393 | 505 070 762 | 505 070 576 | | |
| SUMMIT HM X | 505 070 393 | 505 070 760 | 505 070 144 | | |
| SUMMIT HM Xtreme | 505 070 393 | 505 070 760 | 505 070 144 | | |

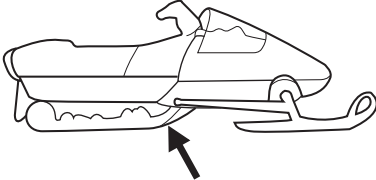
| 2004 | | CENTER SPRINGS | | 2004 | |
|---|---------------------|----------------|---------------------|-------|---------------------|
|  | | | | | |
| MODEL | (P/N) SOFTER SPRING | (P/N) STANDARD | (P/N) HARDER SPRING | MODEL | (P/N) HARDER SPRING |
| MX Z SPORT | 503 189 325 | 503 189 659 | 503 189 686 | | |
| MX Z ADRENALINE | 415 070 500 | 503 189 812 | 503 189 325 | | |
| MX Z TRAIL | 415 070 500 | 503 189 325 | 503 189 659 | | |
| MX Zx | 503 189 325 | 503 189 659 | 503 189 686 | | |
| MX Z RENEGADE | 415 070 500 | 503 189 812 | 503 189 325 | | |
| MX Z FAN | 415 070 100 | 415 070 500 | 503 189 325 | | |
| SUMMIT SPORT | 415 070 100 | 415 070 500 | 503 189 325 | | |
| SUMMIT X | 415 070 100 | 415 070 500 | 503 189 325 | | |
| SUMMIT HM SPORT | 415 070 100 | 415 070 500 | 503 189 325 | | |
| SUMMIT HM X | 415 070 100 | 415 070 500 | 503 189 325 | | |
| SUMMIT HM Xtreme | 415 070 100 | 415 070 500 | 503 189 325 | | |

SECTION 03 - CHASSIS PREPARATION

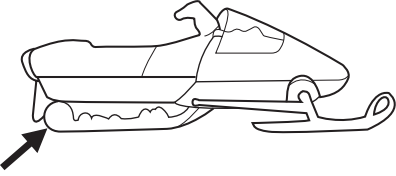
| 2004 | REAR SPRINGS | | | 2004 |
|--|----------------------------------|----------------------------------|----------------------------------|------|
|  | | | | |
| MODEL | (P/N) SOFTER SPRING | (P/N) STANDARD | (P/N) HARDER SPRING | |
| MX Z SPORT | 503 189 594 LH 503 189 592 RH | 503 189 948 LH 503 189 947 RH | 503 189 904 LH 503 189 902 RH | |
| MX Z ADRENALINE | 503 189 629 LH 503 189 627 RH | 503 189 904 LH 503 189 902 RH | 503 189 524 LH 503 189 522 RH | |
| MX Z TRAIL | 503 189 629 LH 503 189 627 RH | 503 189 904 LH 503 189 902 RH | 503 189 524 LH 503 189 522 RH | |
| MX Zx | 503 189 594 LH 503 189 592 RH | 503 189 948 LH 503 189 947 RH | 503 189 904 LH 503 189 902 RH | |
| MX Z RENEGADE | 503 189 629 LH 503 189 627 RH | 503 189 904 LH 503 189 902 RH | 503 189 524 LH 503 189 522 RH | |
| MX Z FAN | Not Applicable | 503 189 594 LH 503 189 592 RH | 503 189 629 LH 503 189 627 RH | |
| SUMMIT SPORT | 503 189 616 LH 503 189 615 RH | 503 189 524 LH 503 189 522 RH | 503 189 675 LH 503 189 674 RH | |
| SUMMIT X | 503 189 616 LH 503 189 615 RH | 503 189 524 LH 503 189 522 RH | 503 189 675 LH 503 189 674 RH | |
| SUMMIT HM SPORT | 503 189 616 LH 503 189 615 RH | 503 189 524 LH 503 189 522 RH | 503 189 675 LH 503 189 674 RH | |
| SUMMIT HM X | 503 189 616 LH 503 189 615 RH | 503 189 524 LH 503 189 522 RH | 503 189 675 LH 503 189 674 RH | |
| SUMMIT HM Xtreme | 503 189 616 LH 503 189 615 RH | 503 189 524 LH 503 189 522 RH | 503 189 675 LH 503 189 674 RH | |

LH = Left Hand RH = Right Hand

SECTION 03 - CHASSIS PREPARATION

SPRING SPECIFICATIONS

Coil Springs Specifications-Steel

| P/N | TYPE | SPRING RATE (lb/in) ± 10 | FREE LENGTH (mm) ± 3 | WIRE DIAMETER (mm) ± .05 | COLOR CODE STRIPES | COLOR OF SPRING |
|-------------|------|-----------------------------|-------------------------|-----------------------------|--------------------|-----------------|
| 486 130 023 | Y | 90 | 295 | 8,25 | BK/BK/BK/BK | YELLOW |
| 486 130 024 | Y | 120 | 315 | 9,19 | GN/GN/GN/GN | YELLOW |
| 486 130 025 | S | 240 | 145 | 8,71 | PI/PI/PI/PI | BLACK |
| 503 189 090 | S | 220 | 200 | 9,19 | YL/WH/YL | BLACK |
| 503 189 812 | 2 | 125-200 | 250 | 8,41 | BL/GN/YL | BLACK |
| 503 189 988 | U | 215 | 64 | 6,35 | GD/GD/YL | BLACK |
| 503 189 990 | R | 275 | 189 | 9,19 | GD/WH/YL | BLACK |
| 503 189 999 | R | 325 | 189 | 9,52 | GD/SI/YL | BLACK |
| 503 190 296 | U | 210 | 65 | 6,65 | WH/BL/YL | BLACK |
| 503 190 299 | S | 275 | 150 | 9,19 | SI/GN/YL | BLACK |
| 505 070 034 | 4 | 60-90 | 325 | 7,77 | BL/GN/BK | YELLOW |
| 505 070 089 | R | 125 | 260 | 7,92 | GN/BK/BK | GOLD |
| 505 070 090 | R | 125 | 235 | 7,49 | BL/BL/BK | COPPER |
| 505 070 091 | 2 | 65-95 | 340 | 8,25 | BK/BL/BK | GOLD |
| 505 070 092 | 2 | 65-95 | 340 | 8,25 | BK/YL/BK | RED |
| 505 070 093 | T | 85 | 290 | 7,77 | BK/GN/BK | RED |
| 505 070 130 | R | 75 | 410 | 6,17 | YL/PI/YL | BLACK |
| 505 070 144 | T | 100 | 390 | 8,25 | RD/BK/RD | YELLOW |
| 505 070 146 | T | 100 | 315 | 8,71 | RD/RD/RD | YELLOW |
| 505 070 153 | 2 | 65-95 | 340 | 8,25 | GN/GN/BK | YELLOW |
| 505 070 233 | U | 125 | 260 | 7,92 | PI/BL/BK | YELLOW |
| 505 070 240 | T | 90 | 265 | 7,49 | RD/PI/BK | YELLOW |
| 505 070 300 | U | 150 | 260 | 8,71 | GN/PI/BK | YELLOW |
| 505 070 302 | U | 100 | 265 | 7,14 | OR/PI/BK | YELLOW |
| 505 070 391 | 2 | 65-95 | 340 | 8,25 | YL/BK/BK | SILVER |
| 505 070 392 | 2 | 55-85 | 320 | 7,77 | RD/GD/YL | BLACK |
| 505 070 394 | R | 125 | 235 | 7,49 | RD/WH/YL | BLACK |
| 505 070 446 | R | 100 | 242 | 7,14 | RD/YL/BK | BLUE |
| 505 070 473 | R | 125 | 260 | 7,92 | BK/YL/RD | SILVER |
| 505 070 474 | 4 | 55-85 | 320 | 7,77 | BK/YL/BL | SILVER |
| 505 070 534 | U | 290 | 45 | 6,17 | BL/WH/YL | BLACK |
| 505 070 536 | T | 150 | 300 | 9,19 | GN/WH/YL | BLACK |
| 505 070 572 | 2 | 55-85 | 320 | 7,77 | RD/BL/BL | SILVER |
| 505 070 575 | U | 290 | 45 | 6,17 | RD/BL/GD | YELLOW |
| 505 070 576 | T | 150 | 300 | 9,19 | RD/BL/WH | YELLOW |
| 505 070 758 | 2 | 45-85 | 320 | 7,49 | RD/GD/BK | YELLOW |

SECTION 03 - CHASSIS PREPARATION

| P/N | TYPE | SPRING RATE (lb/in) ± 10 | FREE LENGTH (mm) ± 3 | WIRE DIAMETER (mm) ± .05 | COLOR CODE STRIPES | COLOR OF SPRING |
|-------------|------|-----------------------------|-------------------------|-----------------------------|--------------------|-----------------|
| 505 070 760 | Y | 95 | 280 | 8,25 | BL/GD/BK | YELLOW |
| 505 070 762 | T | 105 | 300 | 8,71 | GN/GD/BK | YELLOW |
| 505 070 852 | 4 | 40-85 | 340 | 7,49 | RD/GN/RD | YELLOW |
| 505 070 941 | T | 150 | 315 | 9,52 | RD/SL/BK | YELLOW |
| 505 071 200 | T | 105 | 300 | 8,71 | SI/GN/BK | YELLOW |
| 706 000 068 | R | 68 | 355 | 7,77 | GN/WH/BK | YELLOW |
| 706 000 130 | R | 45 | 360 | 6,91 | WH/RD/BK | YELLOW |
| 706 000 172 | R | 45 | 345 | 6,91 | GN/BKRD | YELLOW |
| 706 200 006 | V | 140 | 270 | 8,25 | OR/BK/BK | YELLOW |

Coil Springs Specifications-Titanium

| P/N | TYPE | SPRING RATE (lb/in) ± 10 | FREE LENGTH (mm) ± 3 | WIRE DIAMETER (mm) ± .05 | COLOR CODE STRIPES | COLOR OF SPRING |
|-------------|------|-----------------------------|-------------------------|-----------------------------|--------------------|-----------------|
| 486 130 029 | T | 125 | 300 | N/A | RD/RD/RD/RD | UNPAINTED |
| 486 130 030 | T | 110 | 300 | N/A | BL/BL/BL/BL | UNPAINTED |
| 486 130 031 | T | 95 | 300 | N/A | GD/GD/GD/GD | UNPAINTED |
| 486 130 028 | S | 275 | 150 | N/A | WH/BL/YL | UNPAINTED |

SPRING COLOR CODES

| | | | | |
|------------|-----------|-------------|------------|-------------|
| BK = BLACK | BL = BLUE | GD = GOLD | GN = GREEN | OR = ORANGE |
| PI = PINK | RD = RED | SI = SILVER | WH = WHITE | YL = YELLOW |

Part numbers with a 486 prefix must be ordered from the Valcourt Race Dept. or the Race Support Truck. All other part numbers must be ordered from your local dealer.

SECTION 03 - CHASSIS PREPARATION

Torsion Spring Specification-Steel-Round Wire

| P/N | WIRE DIAMETER (MM) | OPENING ANGLE + - 7 | LENGTH (MM) | COLOR CODE |
|----------------------------------|--------------------|---------------------|-------------|------------|
| 486 071 100 RH 486 071 200 LH | 10,3 | 135 | 400 | YL/YL |
| 486 071 300 RH 486 071 400 LH | 10,3 | 150 | 400 | WH/WH |
| 486 078 500 RH 486 078 600 LH | 10.0 | 115 | 400 | YL/RD |
| 486 093 200 RH 486 093 300 LH | 11.5 | 80 | 400 | GN/YL |
| 486 099 100 RH 486 099 300 LH | 11.89 | 140 | 385 | YL/RD/YL |
| 503 188 100 RH 503 188 200 LH | 11.11 | 100 | 400 | BL/YL |
| 503 189 080 RH 503 189 083 LH | 11.5 | 100 | 385 | GD |
| 503 189 241 RH 503 189 242 LH | 11.11 | 105 | 400 | OR/YL |
| 503 189 327 RH 503 189 329 LH | 11.89 | 100 | 385 | SI |
| 503 189 334 RH 503 189 335 LH | 11.11 | 105 | 400 | YL/GD |
| 503 189 338 RH 503 189 339 LH | 11.11 | 90 | 400 | GN/GN |
| 503 189 342 RH 503 189 343 LH | 10.6 | 80 | 400 | RD/RD/RD |
| 503 189 346 RH 503 189 347 LH | 10.3 | 85 | 400 | YL/YL/YL |
| 503 189 350 RH 503 189 351 LH | 11.5 | 100 | 385 | GD/GD |
| 503 189 354 RH 503 189 355 LH | 10.6 | 90 | 400 | WH/WH/WH |
| 503 189 358 RH 503 189 359 LH | 11.11 | 80 | 400 | BL/BL |
| 503 189 443 RH 503 189 445 LH | 11.11 | 95 | 385 | GN/GN/GN |
| 503 189 522 RH 503 189 524 LH | 11.11 | 90 | 385 | GN/GN/YL |
| 503 189 592 RH 503 189 594 LH | 10.3 | 85 | 385 | GD/RD |
| 503 189 615 RH 503 189 616 LH | 11.11 | 100 | 385 | RD/YL |
| 503 189 627 RH 503 189 629 LH | 10.6 | 90 | 385 | YL/WH |
| 503 189 674 RH 503 189 675 LH | 11.11 | 80 | 385 | GD/YL/YL |
| 503 189 681 RH 503 189 683 LH | 11.9 | 80 | 385 | SI/SI |
| 503 189 881 RH 503 189 883 LH | 11.11 | 75 | 385 | YL/BL |
| 503 189 898 RH 503 189 900 LH | 11.5 | 90 | 385 | GD/GD/GD |

SECTION 03 - CHASSIS PREPARATION

| P/N | WIRE DIAMETER (MM) | OPENING ANGLE + - 7 | LENGTH (MM) | COLOR CODE |
|----------------------------------|--------------------|------------------------|-------------|------------|
| 503 189 902 RH 503 189 904 LH | 10.6 | 80 | 385 | RD/RD/YL |
| 503 189 947 RH 503 189 948 LH | 10.3 | 75 | 385 | GN/YL/YL |
| 503 189 992 RH 503 189 994 LH | 11.11 | 73 | 385 | GN/RD/YL |

LH = Left Hand RH = Right Hand

Torsion Spring Specification-Steel-Square Wire

| P/N | WIRE DIAMETER (mm) | OPENING ANGLE $\pm 7^\circ$ | LENGTH (mm) | COLOR CODE |
|----------------------------------|--------------------|--------------------------------|-------------|------------|
| 503 190 334 RH 503 190 335 LH | 10.3 (Equivalent) | 75 | 385 | YL/RD/RD |
| 503 190 483 RH 503 190 485 LH | 10.6 (Equivalent) | 85 | 385 | YL/BL/YL |
| 503 190 329 RH 503 190 331 LH | 11.1 (Equivalent) | 90 | 385 | RD/SI/YL |

Torsion Spring Specification-Titanium-Round Wire

| P/N | WIRE DIAMETER (mm) | OPENING ANGLE $\pm 7^\circ$ | LENGTH (mm) | COLOR CODE |
|----------------------------------|--------------------|--------------------------------|-------------|------------|
| 486 112 400 RH 486 112 300 LH | 10.3 | 90 | 385 | BL |
| 486 108 600 RH 486 108 700 LH | 10.6 | 75 | 385 | BK |
| 486 112 200 RH 486 112 100 LH | 11.1 | 80 | 385 | GN |
| 486 112 000 RH 486 112 900 LH | 10.3 | 80 | 385 | YL |
| 486 112 600 RH 486 112 500 LH | 10.6 | 100 | 385 | RD |

| SPRING COLOR CODES | | | | |
|--------------------|-----------|-------------|------------|-------------|
| BK = BLACK | BL = BLUE | GD = GOLD | GN = GREEN | OR = ORANGE |
| PI = PINK | RD = RED | SI = SILVER | WH = WHITE | YL = YELLOW |

Part numbers with a 486 prefix must be ordered from the Valcourt Race Dept. or the Race Support Truck. All other part numbers must be ordered from your local dealer.

SECTION 03 - CHASSIS PREPARATION

CORNERING DYNAMICS

The ideal situation, while going through a turn, is to keep the snowmobile as flat as possible without the skis or track losing contact with the driving surface.

As you enter a corner and turn the skis, the rest of the vehicle will want to continue straight ahead. If the skis do not bite the surface, they will start slipping and the vehicle will not turn as tight as the skis are turned. This is called **understeering** or pushing. If the skis bite very well and the track starts sliding out, then the vehicle is **oversteering** or is said to be loose. If the ski and track traction is balanced, then the vehicle will maintain a good line through the corner. Because the center of gravity of the vehicle wants to continue straight ahead and because the center of gravity is above ground level, weight will be transferred to the outside of the vehicle. This causes the machine to roll to the outside. As the radius of the corner gets tighter and/or speeds increase, the machine rolls more, and more weight is transferred to the outside of the vehicle until the front or back loses traction or the vehicle tips over.

Roll can be reduced by installing stiff springs on the front suspension and/or a lot of preload, but this will cause a harsher ride than necessary. Lowering the center of gravity will also reduce roll but there are practical limits as to how low the center of gravity can go. Most vehicles are equipped with an antiroll bar or **stabilizer** bar. Common terminology will refer to it as a **sway** bar. (It is in fact an **anti-sway** bar) The bar is mounted to and pivots on the chassis. The ends of the bar have lever arms from 3" to 7" in length. The ends of the levers are connected to the front suspension. As the outside suspension is compressed during a corner, the bar is twisted and forces the inside spring to compress also. The bar is "borrowing" spring pressure from the inside spring and adding it to the outside spring. The suspension can now resist more chassis roll (see following illustration).

By having a sway bar in the suspension, softer springs can be used to achieve a good ride because the bar will help control roll in a corner. The bar has no effect on ride when traveling straight ahead over bumps that are even from side to side. However, if only one ski encounters a bump, then the bar will transfer energy between the springs. This leads to another design decision. The diameter of the sway bar determines how much spring pressure will be **borrowed** from the opposite spring. A smaller bar will twist more and not transfer as much energy. A larger diameter bar will transfer more energy which will reduce chassis roll, but will produce a harsher ride on uneven, bumpy terrain. A smaller diameter bar will give a more compliant ride on the nasty bumps but it will allow the chassis to roll more in corners. A cross country sled will use small to medium diameter bars while oval and lemans racers will use large diameter bars.

The length of the lever arm also affects the **stiffness** of the sway bar. A shorter lever will **stiffen** the bar and a longer lever will **soften** the bar. Many lever arms will have 2 holes to mount the connector linkage. The hole closest to the bar will act stiffer.

When changing the sway bar diameter you must also change the ball joint blocks and bushings.

For snowcross racing some racers prefer to disconnect the sway bar. This will let the front suspension act more independently, as the suspension is no longer coupled.

Another little known fact that has a large effect on roll is the limiter strap length. As mentioned earlier, if the limiter is lengthened, the front suspension will extend during acceleration, which reduces ski pressure. If this vehicle was in a corner when power was applied, it would have quite a bit of chassis roll and the inside ski will start to lift off of the ground. Shortening the limiter will have a very large affect on controlling roll. A general guideline for initially setting limiter length for good ski pressure and reducing roll is to have the front and back of the track touch the ground at the same time when you set the back of the vehicle down. If the front of the track touches much sooner than the rear, there will be quite a lot of weight transfer and chassis roll during hard cornering.

SHOCKS

Valving and Dampening

In the HPG shock, the piston passages are covered by a stack of thin metal shims of various thicknesses and diameters. The shims provide dampening by acting as spring loaded valves offering resistance to the oil traveling through the piston. There is a stack of shims on both sides of the piston. One side controls compression dampening and the other side controls rebound dampening. By varying the number and thickness of shims the dampening characteristics can be very accurately obtained. There may also be orifices or slits in the piston that are not covered by the shims. These are referred to as bleed slits. The size and number of these slits will also affect dampening. The external adjustment on the MVA, HPG shocks is a variable bleed hole.

Rebound dampening will usually be much stiffer than compression dampening. This is because rebound dampening must resist the force of the spring and because piston speeds are much slower during rebound.

At low piston speeds, the number of bleed slits will have a fairly large effect on dampening, but as piston speeds increase most of the dampening is controlled by the shim stack. This is because the flow area of the slits is much smaller than the flow area under the shims. Since only a small amount of oil can flow through the bleed slits (compared to the amount that flows under the shim stack), the slits have only a very small effect on dampening at high piston speeds. Because of this characteristic, bleed slits are most effective on rebound dampening. They will have only a very slight effect on compression damping because the typical piston speeds on compression strokes are several times faster than on rebound strokes. There really is no such thing as **high speed** rebound dampening.

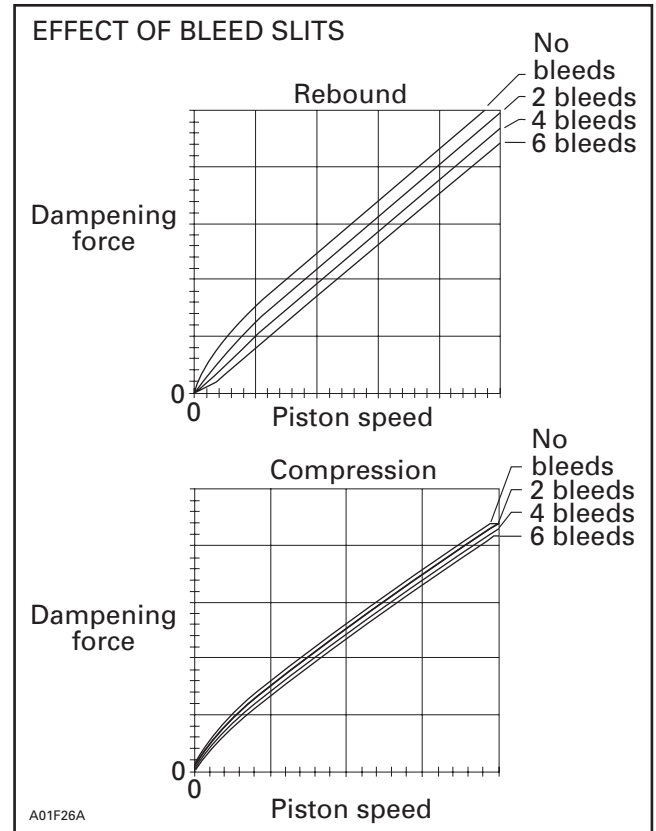

SECTION 03 - CHASSIS PREPARATION

As mentioned earlier, the configuration of the shim stack will control most of the dampening of the shock. There are several methods to tuning shim stacks. The first and most commonly used is to increase or decrease the overall stiffness of the stack. This can be done by changing the number of large shims or by increasing or decreasing their thickness.

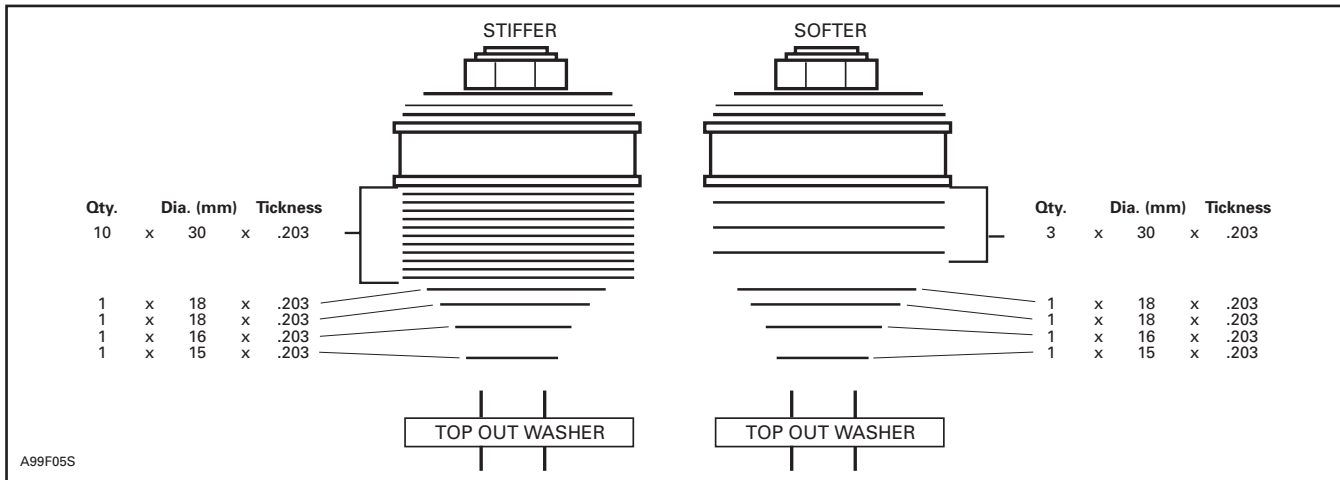

The overall stiffness of the stack has been increased by adding 7-30 mm x .203 mm shims. This will result in firmer dampening at both low and high piston speeds. Thicker shims will also result in firmer dampening but it is better to use more thin shims than fewer thick shims. More thin shims will provide better, smoother dampening than a few thick shims. There is an equivalency between thick and thin shims, though. The following chart indicates how many thin shims are required to equal the stiffness of one thick shim.

| (mm) | |
|----------|--------------|
| 1 x .152 | = 2.4 x .114 |
| 1 x .203 | = 2.3 x .152 |
| 1 x .254 | = 2.0 x .203 |

This means it will take 2.4 x .114 mm shims to have the same dampening as 1 x .152 mm shim. Obviously you can't use a fraction of a shim so you must find the lowest common denominator. For 2.4 it will be 5. For 2.3 it will be 10. The following chart shows the most common possibilities.

| (mm) | |
|-----------|-------------|
| 5 x .152 | = 12 x .114 |
| 10 x .152 | = 24 x .114 |
| 10 x .203 | = 23 x .152 |
| 1 x .254 | = 2 x .203 |
| 2 x .254 | = 4 x .203 |
| 3 x .254 | = 6 x .203 |
| 4 x .254 | = 8 x .203 |
| 5 x .254 | = 10 x .203 |
| 6 x .254 | = 12 x .203 |
| 7 x .254 | = 14 x .203 |
| 8 x .254 | = 16 x .203 |
| 9 x .254 | = 18 x .203 |
| 1 x .305 | = 2 x .254 |
| 2 x .305 | = 3 x .254 |
| 3 x .305 | = 5 x .254 |
| 4 x .305 | = 7 x .254 |
| 5 x .305 | = 9 x .254 |
| 6 x .305 | = 10 x .254 |

The diameter of the smaller shims that support the large shims will also affect the dampening. A larger support shim gives more support to the large shim thus making it act stiffer. Conversely, a smaller diameter support shim will allow the large shim to bend more easily thus softening the dampening. The following graph shows the effect of different diameter support washers.

SECTION 03 - CHASSIS PREPARATION

Shim Comparator Formula

Thickness³ or cubed.

Example: .152 x .152 x .152

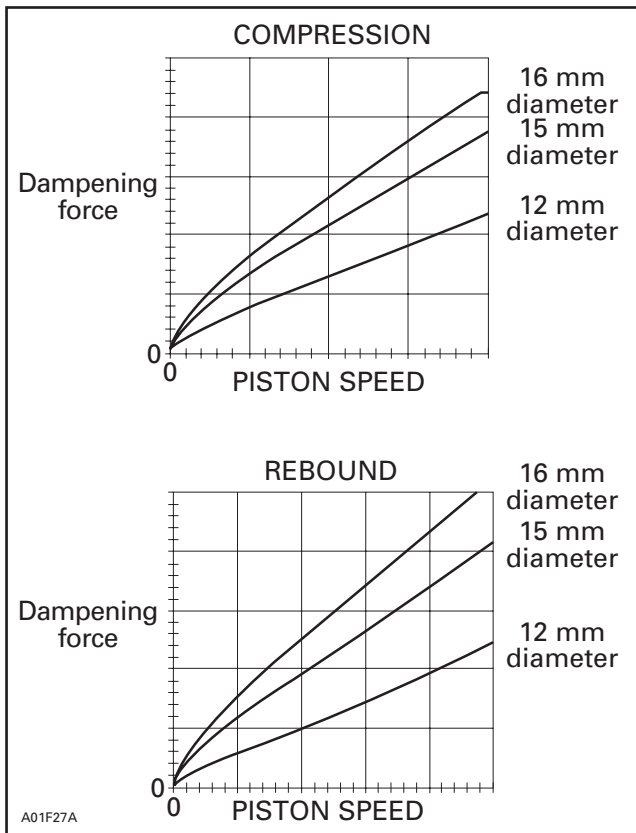

Another method of changing dampening is by controlling the amount of space the stack has to open. This is done by reducing the amount of smaller shims which support the larger shims. The larger shims act the same until they bottom out against the valve stopper.

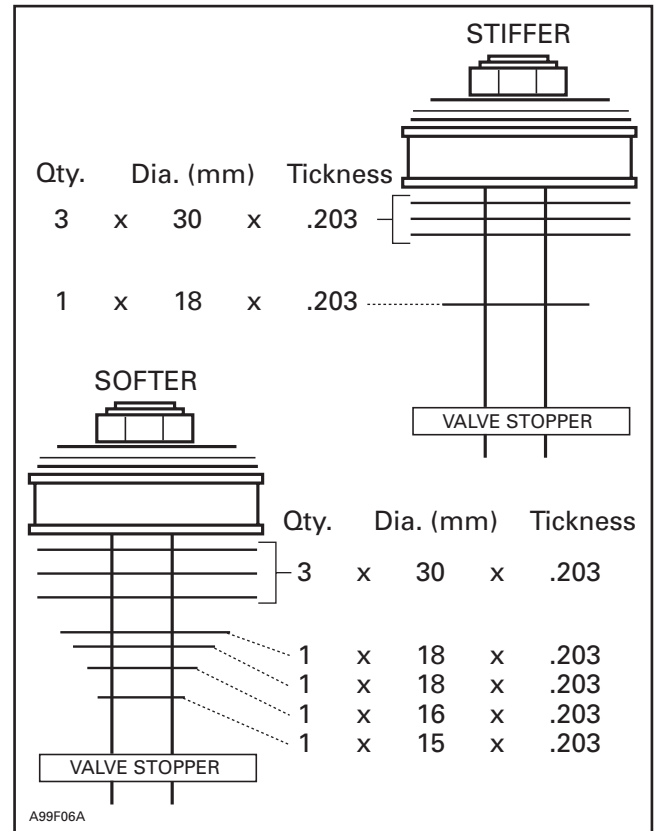

The large shims are only able to deflect .203 mm instead of .610 mm thus reducing the flow area of the piston. This will result in the same low speed dampening, but the medium and high speed dampening will be increased. The following graph represents the effect of changing the total thickness of small shims which determine the amount of large shim deflection.

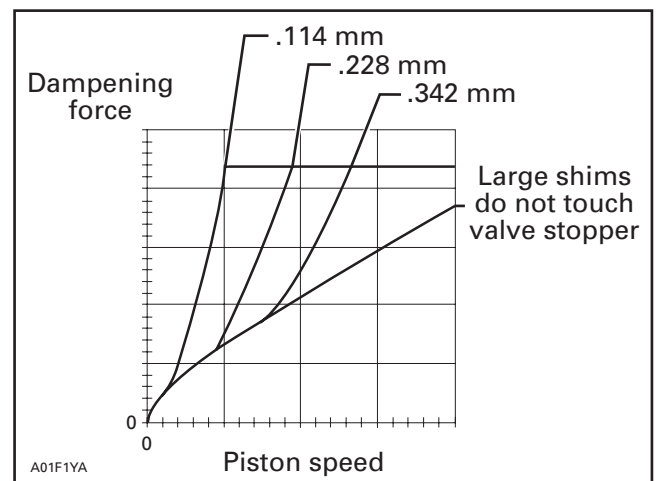

SECTION 03 - CHASSIS PREPARATION

As you can see, low speed dampening remains the same until the shim stack bottoms out against the valve stopper. Then the dampening becomes significantly stiffer. This is sometimes referred to as progressive dampening. Another similar way to achieve this type of dampening is to use multiple stacks of large and small shims.

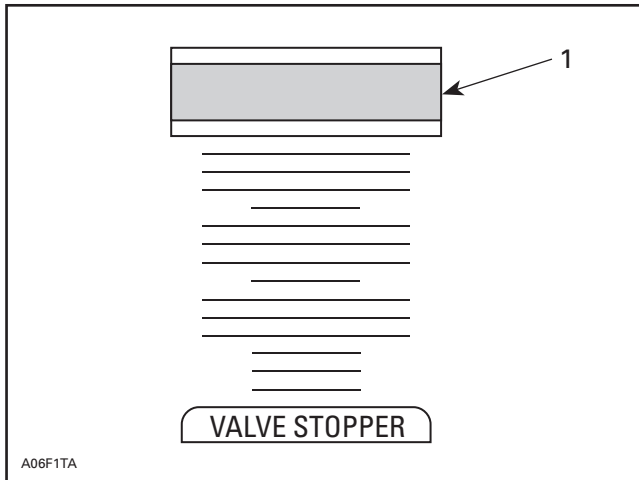

1. Piston

The first stack of large shims will deflect very easily thus giving soft low speed dampening. The number of small shims will determine when the first stack hits the second stack of large shims. Now both stacks are acting together thus stiffening the dampening. This can be repeated several times until the complete stack of large shims bottoms out against the valve stopper.

As you can see, there are an unlimited number of valving combinations and many different versions will achieve very similar results. The following general guidelines should help reduce your tuning time.

- If the dampening is close to what you want, just add or remove 1 or 2 large shims, from the appropriate side, to fine tune the overall stiffness.

NOTE: Always use 30 mm diameter shims against the piston for compression dampening and 26 mm diameter shims against the piston for rebound dampening. Excludes C-46 shock.

- Generally, rebound dampening should not be changed unless a large change in spring rate is made.

- Bleed slit quantity will affect low speed dampening.
- Under dampening may be due to an aerated shock due to low gas pressure and/or old, used oil. Change the oil and recharge the gas pressure to 300 PSI before altering the shock valving.
- If the vehicle bounces or **pogos** a lot, the problem may be too little compression dampening NOT too little rebound dampening. Do not use too much rebound dampening! Excessive rebound dampening is a common error. Overdampening will not allow the suspension to recycle to full extension after an obstacle compresses the suspension. This situation (called packing) will eventually bottom the suspension and not allow it to cycle properly.
- For faster weight transfer under acceleration and deceleration, use a piston with more bleed slits.

Shock Oil and Nitrogen

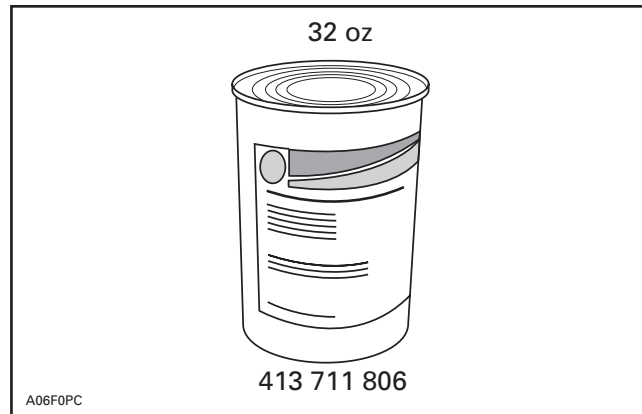

SECTION 03 - CHASSIS PREPARATION

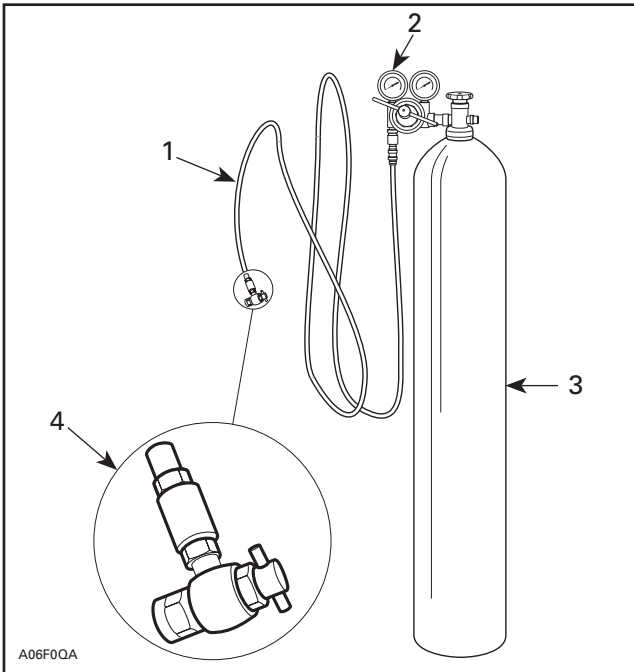

1. Automotive type air pressure hose
2. 2 stage regulator, delivery pressure range 2070 kPa (300 PSI)
3. High pressure cylinder filled with industrial grade nitrogen
4. Valve tip (P/N 529 035 570)

NOTE: Commercially available through compressed gas dealers.

Disassembly and Assembly

Release N₂ (nitrogen) pressure from the damper Schrader valve on any HPG T/A with IFF.

NOTE: When rebuilding a gas emulsion shock, mount the shock vertically in a vice with the schrader valve up and let it sit for 5 minutes before releasing the gas. This 5 minute period will allow most of the gas to separate from the oil and minimize oil spray.

WARNING

Nitrogen gas is under extreme pressure. Use caution when releasing this gas volume. Protective eye wear should be used.

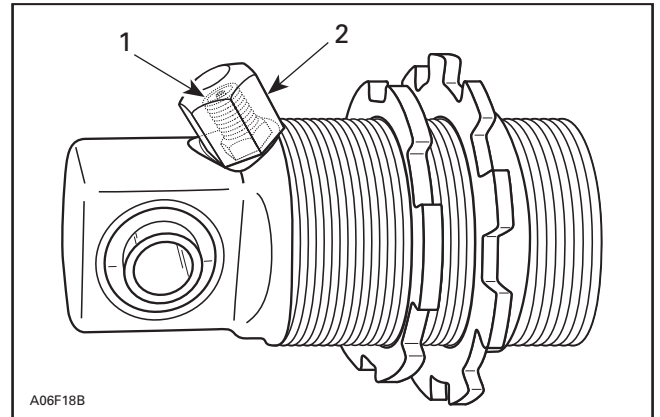

1. Schrader valve 1.5-2 N•m (13-17 lbf•in)
2. Schrader cap 5-6.5 N•m (44-57 lbf•in)

NOTE: Before unscrewing pre-load rings, measure the compressed length of the installed spring and mark position for reinstallation. For factory adjustment refer to the end of this section.

Use tools (P/N 861 743 900) to remove damper spring by unthreading spring pre-load rings, then removing spring retainer or use the spring removal tool (P/N 529 035 504).

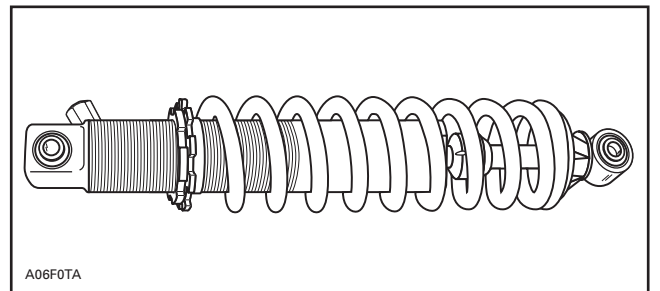

TYPICAL

SECTION 03 - CHASSIS PREPARATION

Holding damper assembly in bench vise with aluminum jaw protectors, unthread seal assembly from damper body using a 32 mm (1.25 in) spanner wrench. This assembly uses a right hand thread.

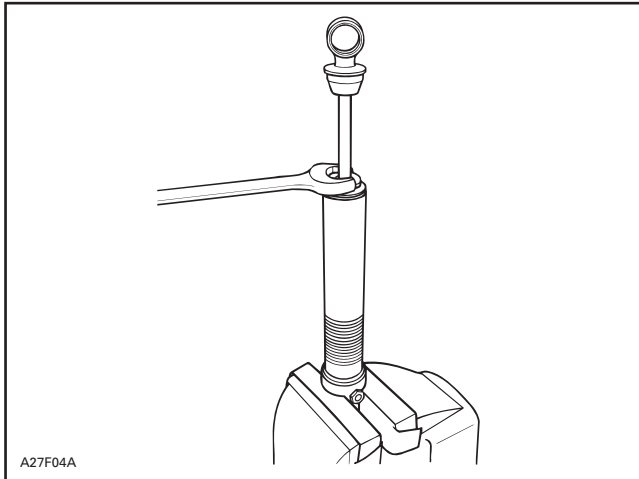

With the seal assembly removed, slowly lift and remove damper rod assembly from the damper body.

NOTE: Remove damper rod assembly slowly to reduce oil spillage and prevent piston seal damage by damper body threads. Wrap the damper body with a shop cloth to capture possible overflow oil while removing the damper piston.

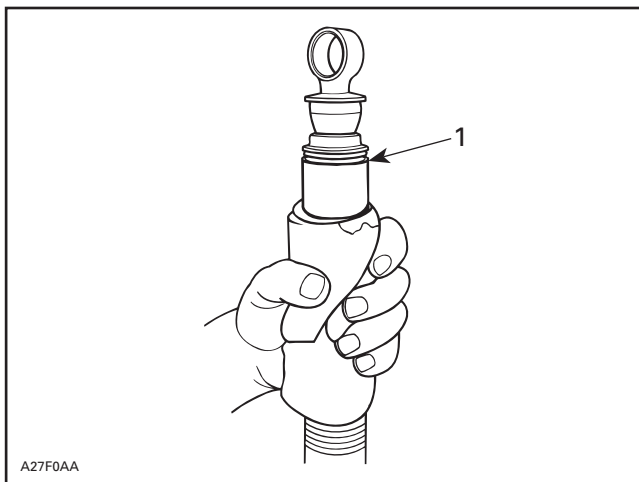

1. Oil flows

Discard old oil into storage container. Never reuse damper oil during shock rebuild.

Remove Schrader valve core. Using compressed air pressure, carefully remove floating piston from damper body. Hold shop cloth over damper body opening to catch released floating piston. Allow room for floating piston to leave damper body.

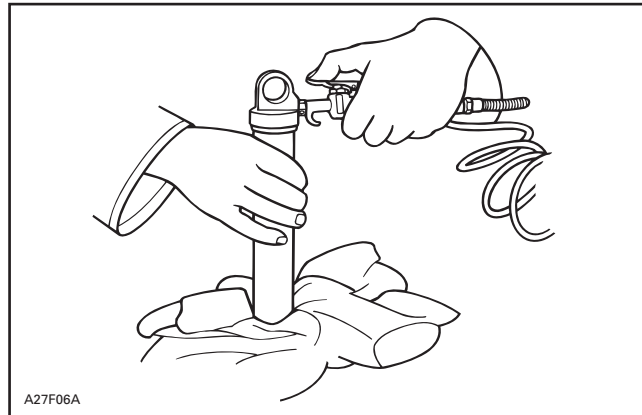

TYPICAL

⚠ WARNING

Whenever using compressed air, use an O.S.H.A. approved air gun and wear protective eye wear.

Thoroughly clean, with a typical cleaning solution, and blow dry using low pressure air. Carefully inspect the damper body for any imperfections or signs of wear in the damper bore.

Replace damper body if wear is identified.

Holding the damper rod assembly in a bench vise, begin piston and valve removal.

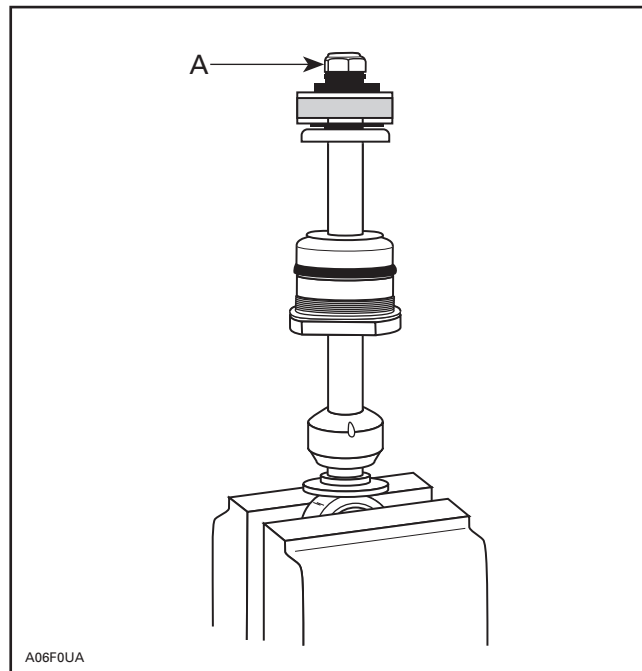

A. Remove damper nut

SECTION 03 - CHASSIS PREPARATION

Always arrange parts removed in the sequence of disassembly.

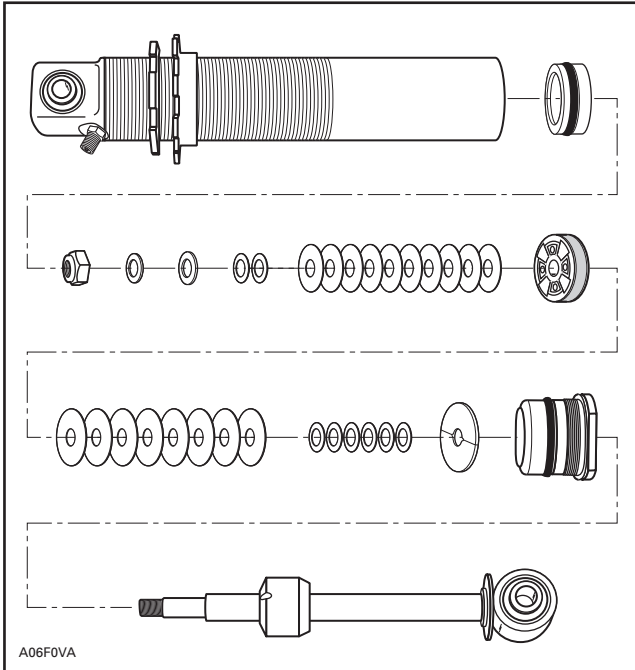

NOTE: As a general rule we suggest replacing the damper rod lock-nut after 4 rebuilds to ensure good locking friction and use Loctite 271 each time.

NOTE: If revalving is to be done, it is imperative that you identify the original shim pack (size and number of shims). The seal carrier need not be removed if only revalving is to be done.

Shims can be measured by using a vernier caliper or a micrometer.

NOTE: All shims should be carefully inspected and any bent or broken shims must be replaced for the shock to function properly.

The damper rod is constructed of a plated shaft design. This damper shaft must be inspected for any visible wear on the surface of the damper rod.

Another check that must be completed if damper seal leakage has been noticed, is damper rod run-out. This damper rod run out must not exceed 0.025 mm (.001 in).

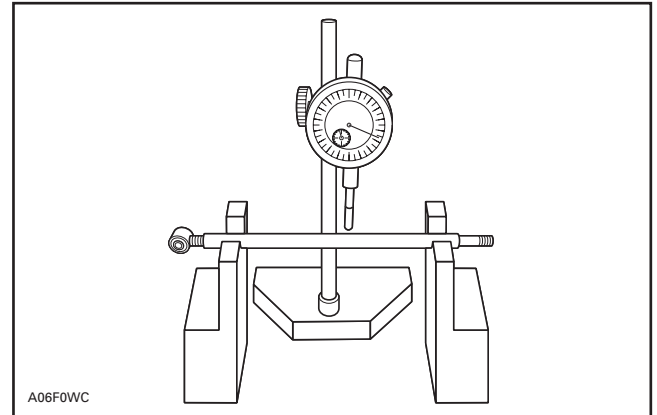

MAXIMUM DEFLECTION 0.025 mm (.001 in)

After the new or replacement shim pack has been selected, reassemble in the reverse order of disassembly. Torque piston nut 11-13 N•m (97-115 lbf•in). Use 271 Loctite.

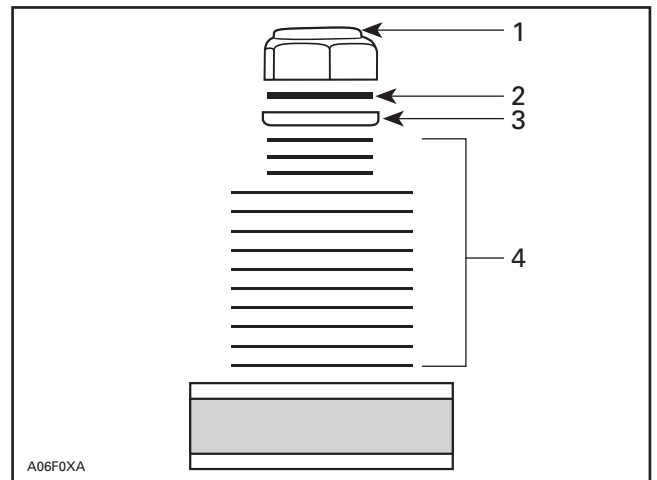

1. Damper nut
2. Spacer
3. Washer
4. Shim pack

CAUTION: The damper rod nut can only be re-used 4 times, then, must be replaced. Do not substitute this part for non – O.E.M. use Loctite 271 on nut each time.

This spacer washer(s) (P/N 414 888 309) must be used as shown to ensure damper rod nut does not bottom out or contact shaft threads.

Rebound valve stopper with round edge facing shim stack.

SECTION 03 - CHASSIS PREPARATION

NOTE: Rebound shim stack must not reach into threads of damper shaft. Washer under damper shaft nut is used to prevent damper shaft nut from bottoming on threads.

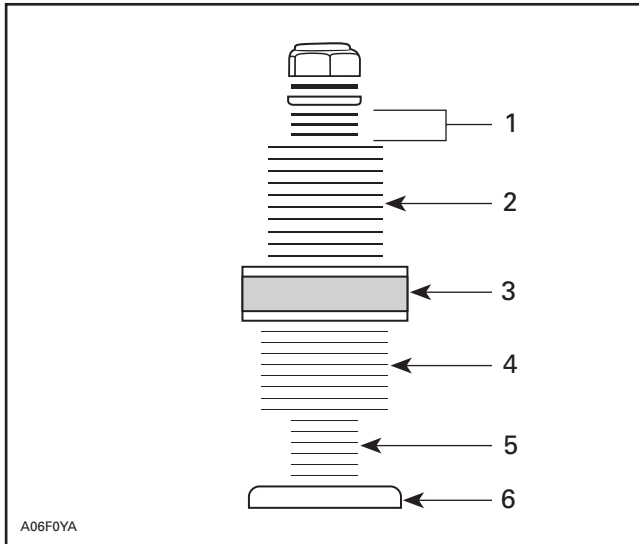

1. Rebound dampening shim pack
2. Rebound dampening shim pack
3. Piston
4. Compression dampening shim
5. Compression dampening shim pack
6. Stopper

Rebound

A minimum of 0.203 mm (.008 in) clearance must be allowed between shim stack and rebound valve stopper. Use at least one shim of 12 × .203 mm.

Whenever tuning for more rebound damping always use 26 mm (1.02 in) shims against piston to properly close piston orifice holes. More thin shims will offer more control than a few thick shims of the same overall thickness.

NOTE: When tuning for less dampening it is important to remember, never use less than 3-26 mm (1.02 in) shims against piston. This will guard against fatigue breakage.

Piston options include 5 pistons; 0, 1, 2, 4 and 6 slits for rebound dampening bleeds.

Compression

Whenever tuning for more compression dampening always use 30 mm (1.18 in) shims against piston to properly close piston orifice holes. Two thin shims will offer more control than one thick shim of the equal thickness.

NOTE: When tuning for less dampening it is important to remember, never use less than 3 shims against piston. This will guard against fatigue breakage.

Fewer spacer shims will result in more high speed dampening. A minimum of 0-114 mm (.0045 in) clearance should be allowed between shim stack and compression valve stopper. Use at least one shim of 12 × .114.

If the seal carrier assembly is replaced, use seal pilot to guide seal over damper shaft. Lubricate seal carrier guide pilot before use.

CAUTION: Failure to use seal pilot will result in seal damage.

Reassemble damper rod assembly, taking care to properly assemble shim packs as required for your dampening needs. Ensure that the shaft piston is installed with the slits/larger intake holes facing the rebound shim stack.

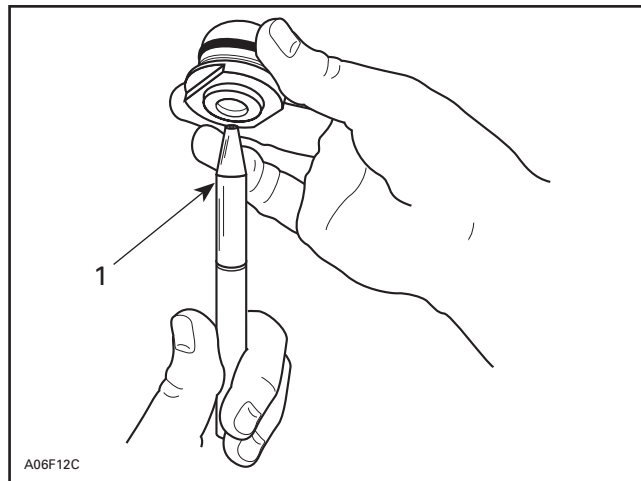

1. Pilot (P/N 529 026 900)

SECTION 03 - CHASSIS PREPARATION

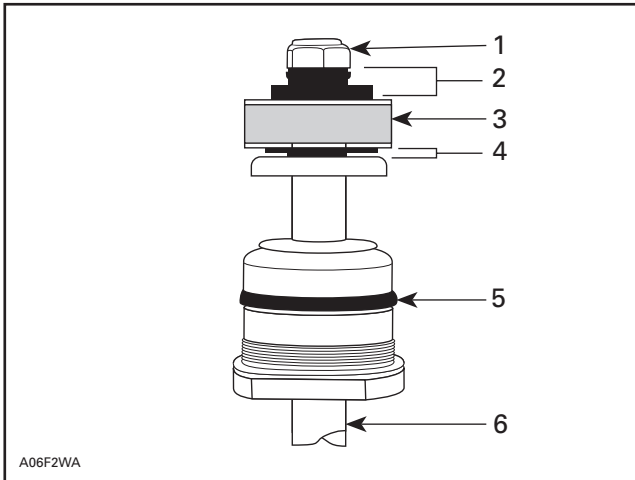

1. Damper nut torque 11-13 N•m (97-115 lbf•in) use Loctite 271
2. Rebound shim pack
3. Piston
4. Compression shim pack
5. O-ring visual inspection seal carrier assembly
6. Damper rod

Reinstall floating piston into damper body (ensure that Schrader valve core has been removed). Use molybdenum disulfide grease (example: molykote paste (P/N 413 703 700) or silicone grease Dow Corning MS4 (P/N 420 897 061) to ease O-ring past damper body threads with floating piston pilot (P/N 529 026 600).

CAUTION: Failure to install IFP correctly could result in shock damage.

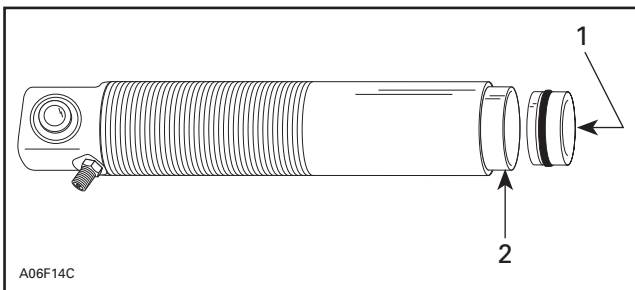

1. Push (slowly) by hand
2. Floating piston guide (P/N 529 026 600)

NOTE: Lubricate inside of piston guide with molykote GN paste (P/N 413 703 700) or MS4 silicone grease (P/N 420 897 061).

Install floating piston to the proper depth.

On all HPG take apart shocks from 1996 on. The floating piston is installed hollow side up.

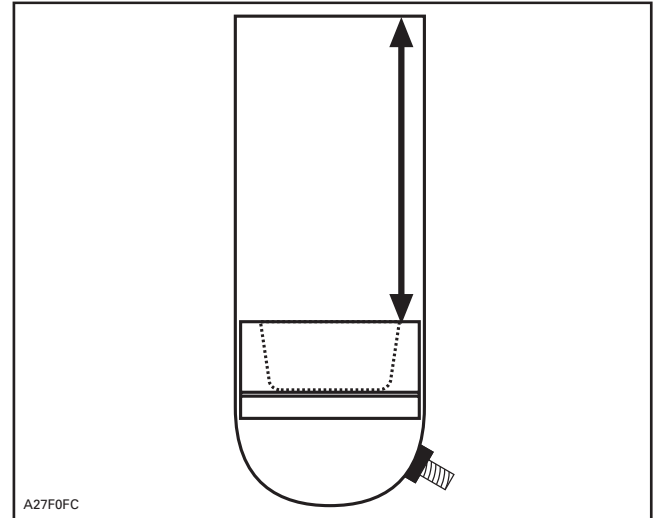

Required distance for floating piston installation.

NOTE: If the floating piston is installed too far into the damper body, light air pressure through Schrader valve (with core removed) will move piston outward.

NOTE: Reinstall Schrader valve core after IFP has been installed at correct height and before adding oil.

WARNING

Whenever using compressed air exercise extreme caution, cover damper opening with shop cloth to reduce chance of possible injury.

CAUTION: Moisture laden compressed air will contaminate the gas chamber and rust floating piston.

WARNING

Always wear protective eye wear whenever using compressed air.

SECTION 03 - CHASSIS PREPARATION

Fill the shock with Bombardier HPG shock oil (P/N 413 711 806) to approximately 10 mm (.393 in), from the base of seal carrier threads.

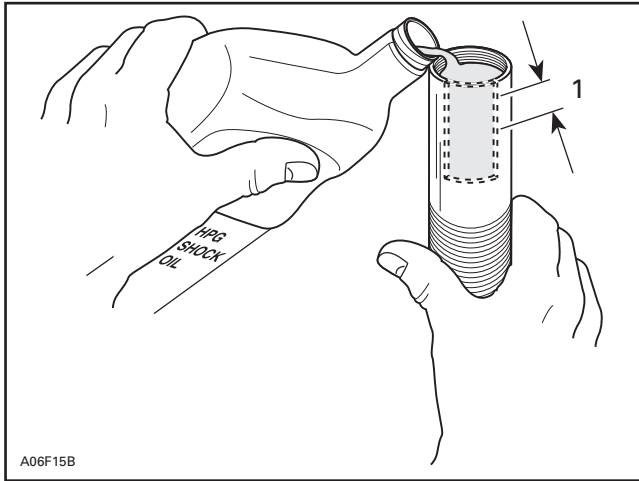

1. Fill to 10 mm (.393 in)

NOTE: Although we do not measure the exact amount of oil added to the damper, approximately 106 mL (3.58 oz U.S.) will be used.

Carefully insert damper rod into the damper body. Install damper rod assembly into the damper body. Lightly oil damper piston seal ring with shock oil to ease installation.

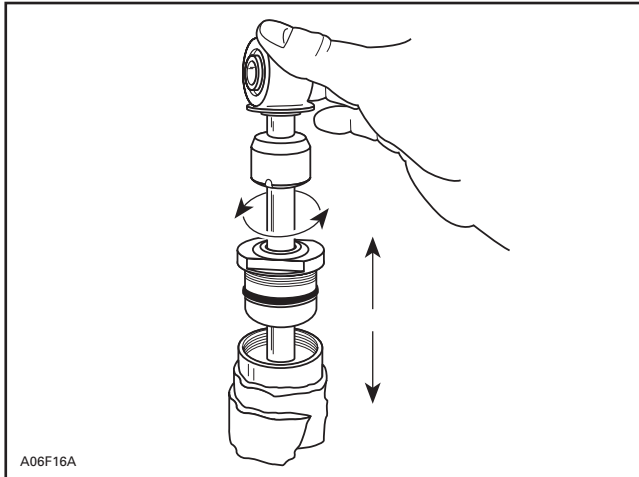

NOTE: Some shock oil will overflow when installing damper. Wrap damper with shop cloth to catch possible overflow oil.

CAUTION: Use care when passing piston into damper body at damper body threads.

Slight oscillation of damper rod may be required to allow piston to enter damper body bore.

Slowly push piston into damper body. Slight up and down movement may be required to allow all air to pass through piston assembly. The gentle tapping of a small wrench, on the shock eye, may help dislodge air trapped in the submerged piston. Be careful not to drive the shaft any deeper into the oil than is necessary to just cover the shim stack.

NOTE: Fast installation of the damper rod may displace the floating piston from its original position. This must not occur if the damper is expected to perform as designed.

With damper rod piston into-oil, TOP OFF damper oil volume. Oil level should be to damper body thread base.

Seal carrier assembly can now be threaded into damper body. This should be done slowly to allow weepage of oil and to minimize IFP displacement. After the seal carrier is fully in place avoid pushing the shaft into the body until the nitrogen charge is added.

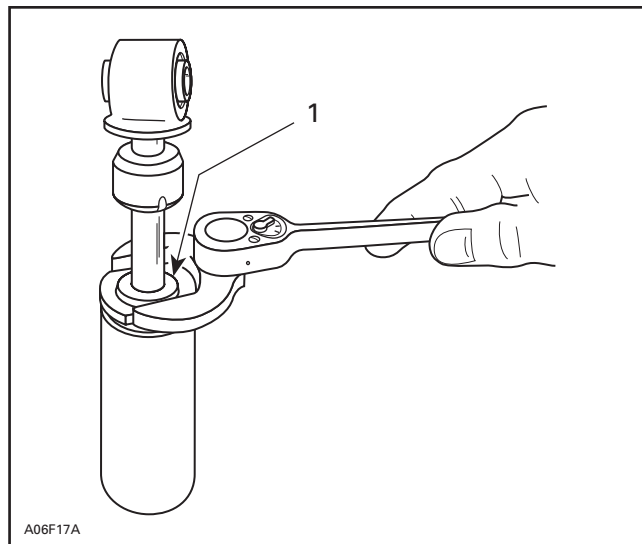

1. Torque seal carrier to 88-89 N•m (65-66 lbf•ft)

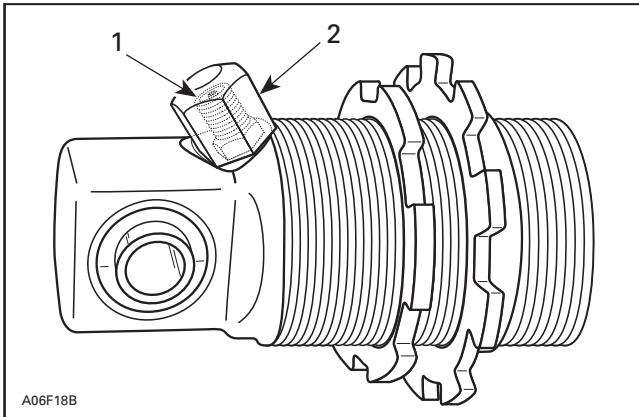

1. Schrader valve 1.5-2 N•m (13-17 lbf•in)
2. Schrader cap 5-6.5 N•m (44-57 lbf•in)

Adding Gas Pressure

Nitrogen (N₂) can now be added to damper body.

NOTE: Never substitute another gas for nitrogen. Nitrogen has been selected for its inert qualities and will not contaminate the gas chamber of the shock.

Preset your pressure regulator to 2070 kPa (300 PSI) nitrogen (N₂), this gas pressure will restore the correct pressure for your damper.

CAUTION: Do not exceed the recommended pressure values.

When removing and retightening the Schrader valve acorn nut use minimal torque. When the cap is over tightened and subsequently removed it may prematurely break the seal of the Schrader valve to the shock body and cause a loss of nitrogen charge without being noticed. If you suspect this has happened then recharge the shock as a precaution. Inspect the acorn cap before installation to ensure that the internal rubber gasket is in its proper position.

⚠ WARNING

Whenever working with high pressure gas, use eye wear protection. Never direct gas pressure toward anybody.

NOTE: Carefully inspect damper for gas or oil leaks. Any leaks must be corrected before continuing.

Damper gas pressure cannot be confirmed by using a pressure gauge. The volume of gas in the shock is very small, and the amount lost during gauge installation will lower the pressure too much and require refilling.

After recharging is complete and before installing the spring the rebuilt shock should be bench-tested. Stroke the shock to ensure full travel and smooth compression and rebound action. If the shaft moves in or out erratically this could indicate too much air is trapped inside. If the shaft will not move or has partial travel then it may be hydraulically locked. In either event the shock must be rebuilt again. Pay particular attention to the placement of the IFP, quantity of oil and shim stack/piston assembly.

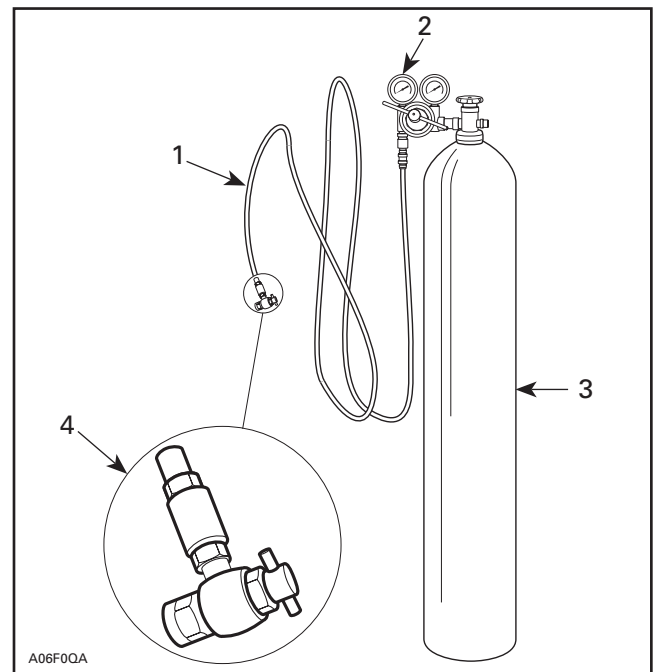

1. Automotive type air pressure hose
2. 2 stage regulator, delivery pressure range 2070 kPa (300 PSI)
3. High pressure cylinder filled with industrial grade nitrogen
4. Valve tip (P/N 529 035 570)

Reinstall damper spring retainer, then your spring. Next, thread the spring pre-load rings up to the spring. Set pre-load according to recommended spring length specifications. Your damper is now ready for reinstallation to your snowmobile.

SECTION 03 - CHASSIS PREPARATION

INTERNAL FLOATING PISTON MEASUREMENT

| SHOCK P/N | MEASUREMENT mm |
|-------------|-------------------|
| 505 070 903 | 44.5 |
| 505 070 904 | 44.5 |
| 505 070 937 | 44.5 |
| 505 070 938 | 44.5 |
| 503 190 016 | 128 |
| 503 190 247 | 128 |
| 503 190 289 | 130 |
| 503 190 008 | 132 |
| 503 190 019 | 132 |
| 503 190 201 | 132 |
| 503 190 015 | 134 |
| 503 190 017 | 134 |
| 503 190 226 | 134 |
| 505 070 753 | 176 |
| 503 190 007 | 185 |
| 503 190 205 | 185 |
| 503 190 290 | 185 |
| 505 070 966 | 186 |
| 505 071 111 | 186 |
| 503 190 020 | 187 |
| 503 190 024 | 187 |
| 503 190 013 | 188 |
| 503 190 248 | 188 |

NOTE: If the floating piston is installed too far into the damper body, light air pressure through valve (with the core removed) will move the piston outward.

2004 MX Z X 440 HPG C-36 Shock Part List

| P/N | DESCRIPTION |
|-------------|---|
| 505 070 953 | Shock ass'y left front |
| 505 070 952 | Shock ass'y right front |
| 503 189 972 | Shock ass'y center |
| 503 189 974 | Shock ass'y rear |
| 486 140 026 | Stop ring (spring protector) right & left |
| 486 140 027 | Collar (spring protector) right & left |
| 486 140 028 | Rubber bush (top eye) |
| 486 140 029 | Valve ass'y (base valve adjusters) |
| 486 140 030 | Bearing comp (seal head) |
| 486 140 031 | Label |
| 486 140 032 | Nut (hose) |
| 486 140 033 | O-ring (hose) |
| 486 140 034 | Packing (brass washer hose) |
| 486 140 035 | Bolt (hose) |
| 486 140 036 | Hose comp right & left |
| 486 140 037 | Hose comp center |
| 486 140 038 | Hose comp rear |
| 486 140 039 | Guide spring (abutment) |
| 486 140 040 | O-ring (remote cover) |
| 486 140 041 | Stop ring (remote cover) |
| 486 140 042 | Guide (remote cover) |
| 486 140 043 | O-ring (air valve) |
| 486 140 044 | Screw (air valve) |
| 486 140 045 | Air valve comp |
| 486 140 046 | Piston ring (floating) |
| 486 140 047 | O-ring (floating) |
| 486 140 048 | Free piston |
| 486 140 049 | Tank comp (remote) right & left |
| 486 140 050 | Tank comp (remote) center |
| 486 140 051 | Tank comp (remote) rear |
| 486 140 052 | Cylinder comp right & left |
| 486 140 053 | Cylinder comp center |
| 486 140 054 | Cylinder comp rear |
| 486 140 055 | Piston rod sub ass'y right & left |
| 486 140 056 | Piston rod sub ass'y center |
| 486 140 057 | Piston rod sub ass'y rear |

C-36 HPG shocks use the same valve shims as other model HPG shocks except C-46.

2004 MX Z X 440 HPG C-36 SHOCKS

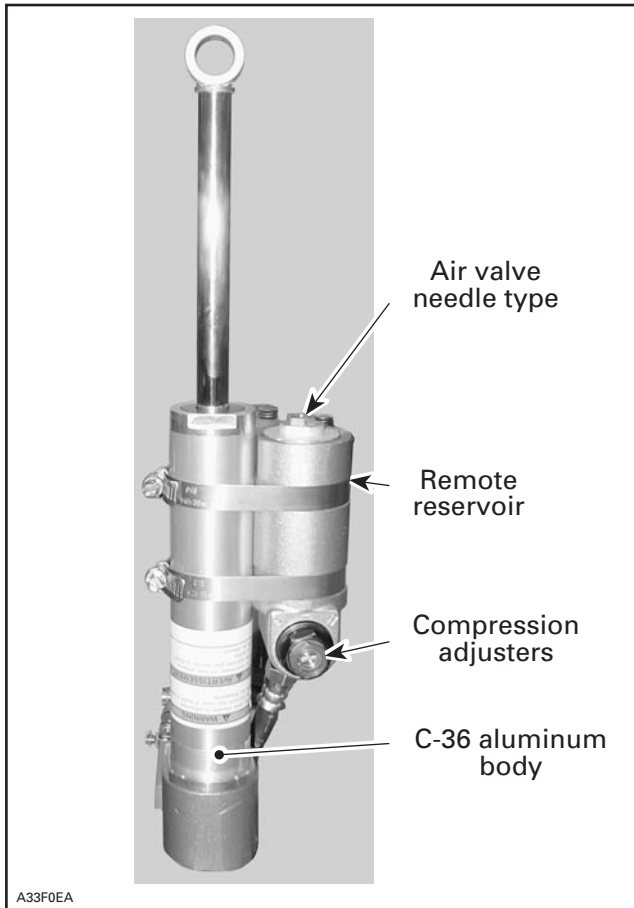

The 2004 MX ZX 440 REV will come equipped with four C-36 HPG shocks. Each shock will be equipped with high and low speed adjustable compression dampening (rear shock pictured).

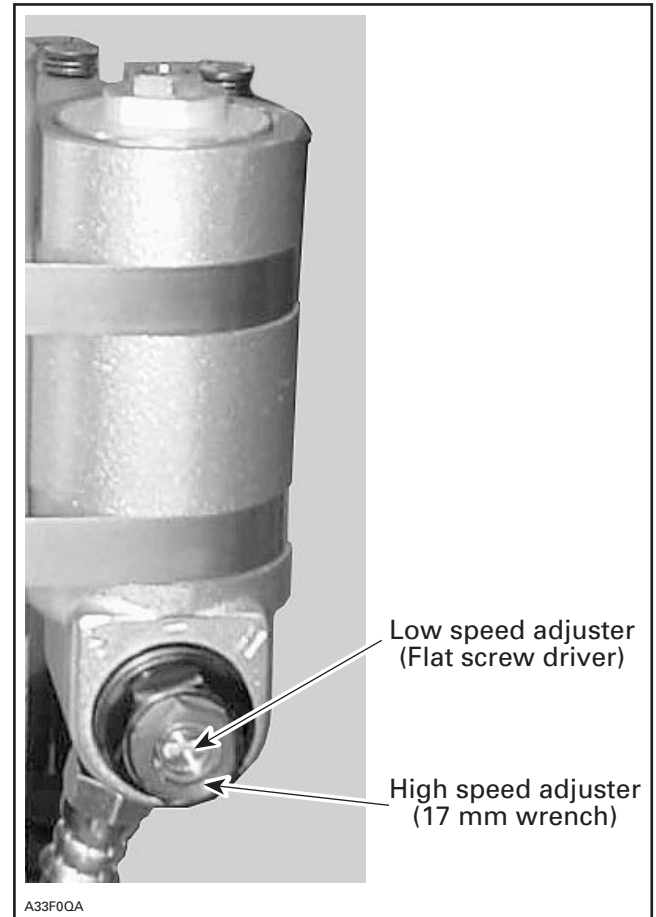

Low speed compression adjuster

The low speed adjustment is used to change the dampening force for relatively slow suspension movement. It is used to tune the vehicle for braking, cornering, holeshots and all the bumps that create low speed movement in the suspension. The low speed adjuster has 4 turns of adjustment. Turning the adjuster clockwise increases the dampening.

High speed compression adjuster

The high speed adjustment is used to change the dampening force for fast suspension. It is used to tune the vehicle for large, high speed jumps and bumps that create high speed movement in the suspension. The high speed adjuster has three turns of adjustment. Turning the adjuster clockwise increases the dampening.

SECTION 03 - CHASSIS PREPARATION

SHOCK REBUILD PROCEDURE

1. Tightly secure the shock base in vise. **DO NOT CLAMP ONTO SHOCK BODY.**
2. Using a 12 mm wrench, slowly remove air valve, allowing the gas inside the reservoir to escape.
3. Remove top seal cap using a 36 mm wrench. Pull shaft/valve stack assembly out of main shock body.

5. Push down the remote reservoir cover, remove the retaining clip.



6. Remove the remote reservoir cover.

4. Dispose of used oil properly.



SECTION 03 - CHASSIS PREPARATION

7. Remove the floating piston inside the remote reservoir.



8. Remove lock nut using a 14 mm wrench securing valve stack and piston to shaft.

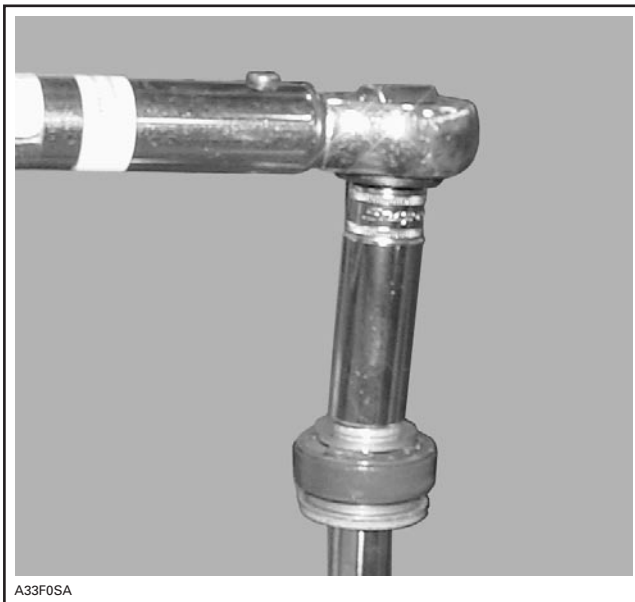

9. Carefully remove and layout shims, washers, and piston from shaft. Pay close attention to shim sequence and piston position.

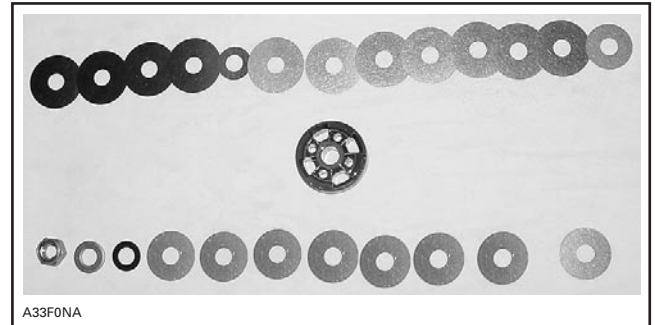

10. Clean all shock components using Bombardier Sheave Cleaner. **DO NOT MIX SHIMS AND WASHERS TOGETHER.**
11. Assemble valve shims, washers, and piston in proper order and place them back onto shock shaft.
12. Torque the rod nut at 24-27 N•m (18-20 lbf•ft).

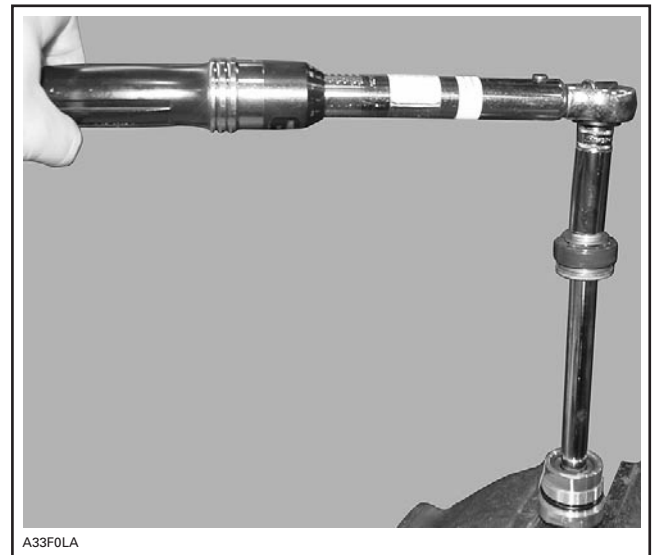

13. Fill main shock body with shock oil (P/N 413 711 806) to a level of half full.
14. Fill remote reservoir with Bombardier shock oil to within 6.4 mm (1/4 inch) from the top.
15. Hold the remote reservoir as to have the oil level in it at the same height of the oil level in the shock.

SECTION 03 - CHASSIS PREPARATION

16. Cup your hand and place it over the remote reservoir. Pump with your hand to circulate oil through the base valve (adjustment system) to remove any trapped air. Low speed adjuster must be open 1 turn minimum.
17. Fill the remote reservoir with oil. Lubricate O-ring seal on floating piston with shock oil and install. The key to good shock performance is to remove all the air from shock body, reservoir, and valve stack.



18. Push the floating piston to the bottom of the remote reservoir. Oil will rise in the main shock body almost to the top.
19. Fill the shock body with oil until level with bottom of threads.
20. Lubricate seal around piston and valve stack and gently push into main shock body.
21. Stroke the piston and valve stack slowly to remove any trapped air. Using a small hammer or wrench, gently tap on the shaft mounting eyelet to help remove air.

22. Again, push the floating piston to the bottom of the remote reservoir.
23. Pull the shock shaft as far out as possible and replace the seal cover and torque to 89-101 N•m (66-74 lbf•ft). Oil must spill from the shock body before the seal cover O-ring seals the shock.
24. Install the remote reservoir cover. Install the retaining clip. Pull cover to seat against the retaining clip. Make sure the cover is firmly seated against the retaining clip before filling with gas.
25. Install air inlet valve.
26. Pressurize the shock at 2068 kPa (300 PSI) with nitrogen. Use the correct needle tool (P/N 529 035 614).



27. Install the safety screw into the air inlet valve and clean your shock with Bombardier Sheave Cleaner.

SECTION 03 - CHASSIS PREPARATION

SHOCK VALVING

Front

| | |
|-------------|-----------------------|
| Compression | 7 x 30 x 0.152 |
| | 1 x 19 x 0.152 |
| | 3 x 30 x 0.203 |
| | 3 x 13 x 0.114 |
| | 1 slit piston 2 x 0.3 |
| Rebound | 3 x 26 x 0.254 |
| | 1 x 13 x 0.203 |

Center

| | |
|-------------|-----------------------|
| Compression | 5 x 30 x 0.203 |
| | 1 x 21 x 0.114 |
| | 4 x 30 x 0.254 |
| | 2 x 22 x 0.152 |
| | 1 slit piston 2 x 0.3 |
| Rebound | 1 x 26 x 0.254 |
| | 1 x 16 x 0.114 |
| | 7 x 26 x 0.254 |
| | 1 x 16 x 0.114 |

Rear

| | |
|-------------|-----------------------|
| Compression | 4 x 30 x 0.152 |
| | 1 x 18 x 0.114 |
| | 7 x 30 x 0.254 |
| | 1 x 24 x 0.254 |
| | 1 slit piston 2 x 0.3 |
| Rebound | 2 x 26 x 0.254 |
| | 1 x 16 x 0.114 |
| | 6 x 26 x 0.254 |
| | 1 x 16 x 0.114 |

C-36 HPG

SHIMS

| P/N | SIZE (mm) | MOQ (minimum order quantity) |
|-------------|-----------|---------------------------------|
| 415 039 100 | 30 x .254 | 5 |
| 414 888 318 | 30 x .203 | 15 |
| 414 888 319 | 30 x .152 | 1 |
| 414 888 320 | 28 x .203 | 5 |
| 414 888 321 | 28 x .152 | 5 |
| 415 039 000 | 26 x .254 | 5 |
| 414 888 322 | 26 x .203 | 5 |
| 414 888 323 | 26 x .152 | 50 |
| 414 888 324 | 22 x .203 | 5 |
| 414 888 325 | 22 x .152 | 5 |
| 414 888 326 | 20 x .203 | 5 |
| 414 888 327 | 20 x .152 | 5 |
| 414 888 328 | 20 x .144 | 5 |
| 414 888 329 | 18 x .203 | 5 |
| 414 888 330 | 18 x .152 | 5 |
| 414 888 331 | 16 x .254 | 10 |
| 414 888 332 | 16 x .203 | 10 |
| 414 888 333 | 16 x .152 | 10 |
| 415 038 900 | 16 x .114 | 10 |
| 414 888 334 | 15 x .254 | 10 |
| 414 888 335 | 15 x .203 | 10 |
| 414 888 336 | 15 x .152 | 10 |
| 414 888 337 | 15 x .114 | 10 |
| 414 888 338 | 12 x .203 | 10 |
| 414 888 339 | 12 x .152 | 10 |
| 415 038 800 | 12 x .114 | 10 |
| 414 888 340 | 21 x .114 | 10 |
| 414 888 341 | 24 x .114 | 10 |

PISTONS

| P/N | SIZE | MOQ (minimum order quantity) |
|-------------|---------|---------------------------------|
| 414 888 304 | 0 slit | 1 |
| 414 888 305 | 2 slits | 2 |
| 414 888 306 | 4 slits | 1 |
| 414 888 307 | 6 slits | 1 |
| | 1 slit | |

SECTION 03 - CHASSIS PREPARATION

C-46

REAR SHOCK SHIMS

| P/N | SIZE (mm) | MOQ (minimum order quantity) |
|-------------|-----------|------------------------------------|
| 503 189 011 | 22 × .114 | 5 |
| 503 189 012 | 22 × .152 | 5 |
| 503 189 013 | 22 × .203 | 5 |
| 503 189 014 | 22 × .254 | 5 |
| 503 189 015 | 22 × .305 | 5 |
| 503 189 016 | 24 × .114 | 5 |
| 503 189 017 | 24 × .152 | 5 |
| 503 189 018 | 24 × .203 | 5 |
| 503 189 019 | 24 × .254 | 5 |
| 503 189 020 | 24 × .305 | 5 |
| 503 189 021 | 26 × .114 | 5 |
| 503 189 022 | 26 × .152 | 5 |
| 503 189 023 | 26 × .203 | 5 |
| 503 189 024 | 26 × .254 | 5 |
| 503 189 025 | 26 × .305 | 5 |
| 503 189 026 | 28 × .114 | 5 |
| 503 189 027 | 28 × .152 | 5 |
| 503 189 028 | 28 × .203 | 5 |
| 503 189 029 | 28 × .254 | 5 |
| 503 189 030 | 28 × .305 | 5 |
| 503 189 031 | 30 × .114 | 5 |
| 503 189 032 | 30 × .152 | 5 |
| 503 189 033 | 30 × .203 | 5 |
| 503 189 034 | 30 × .254 | 5 |
| 503 189 035 | 30 × .305 | 5 |
| 503 189 036 | 36 × .152 | 5 |
| 503 189 037 | 36 × .203 | 5 |
| 503 189 038 | 36 × .254 | 5 |
| 503 189 039 | 40 × 114 | 5 |
| 503 189 040 | 40 × 203 | 5 |
| 503 189 041 | 40 × 254 | 5 |

PISTONS

| P/N | SIZE | MOQ (minimum order quantity) |
|-------------|------|------------------------------------|
| 503 189 004 | 0.0 | 1 |
| 503 189 003 | 1.2 | 1 |
| 503 189 002 | 1.7 | 1 |
| 503 189 001 | 2.0 | 1 |

SECTION 03 - CHASSIS PREPARATION

CHASSIS SET-UP

General

Reducing rolling resistance of a snowmobile is also an important area to explore when you are searching for the ultimate top speed. The horsepower required to overcome rolling resistance or drag increases approximately with the square of velocity so small reductions here can provide measurable improvements in top speed.

Good chassis set up starts with accurate alignment of the drive axle, countershaft, suspension system, and chassis. Use the following procedure to check your vehicle:

Remove the rear suspension, driven clutch, tuned pipe and muffler, track and drive axle. Check to see that the spacing of the drive sprockets is correct on the drive axle. The sprockets should be centered in the space between the rows of internal drive lugs on the track.

Use a press or special tool (P/N 861 725 700) for shifting the sprockets. The sprocket indexing should also be checked. The maximum desynchronization is 1/16 inch (1.5 mm). The drive axle can be chucked in a lathe and spun to observe the sprocket "wobble" and run out. Wobble should not exceed 2 mm (.080 in). While this amount of wobble may look excessive, it does not affect performance. If wobble is more than allowed, the sprockets should be replaced.

Maximum run out should not exceed 0.5 mm (.020 in). A maximum of 1 mm (.040 in) can be removed from the sprockets to true the diameter.

CAUTION: Do not remove more than 1 mm (.040 in) of material or the sprockets will start to go out of pitch with the track.

Now, reinstall the drive shaft. Using a large carpenter's square, check to see that the drive axle is square (90°) with the tunnel. If not, slot the left end bearing housing holes and shim the chaincase to square up the drive axle and the countershaft.

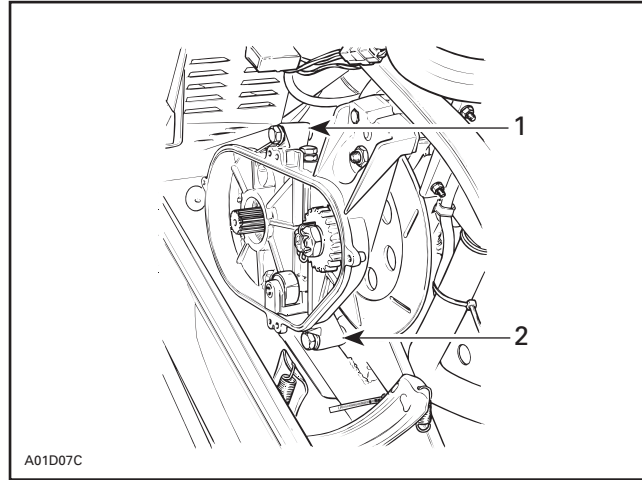

TYPICAL

1. Shim location
2. Shim location

Reinstall the rear suspension and using a square check to see that the runners are square (90°) with the drive axle. If not, cut and shim the ends of the suspension cross tubes to perfectly align the runners and also remove any side-to-side movement. If the suspension must be shimmed, correlate the adjustment with the next step.

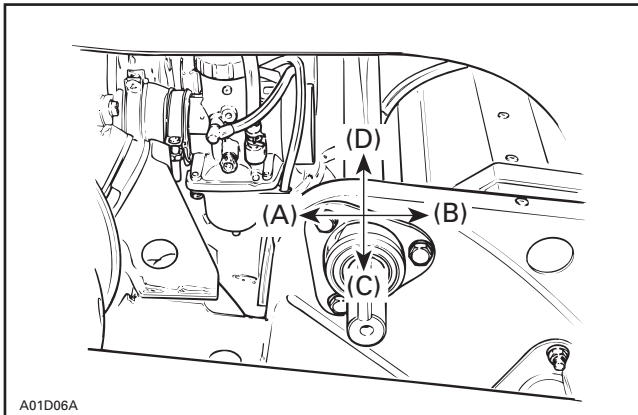

TYPICAL

SECTION 03 - CHASSIS PREPARATION

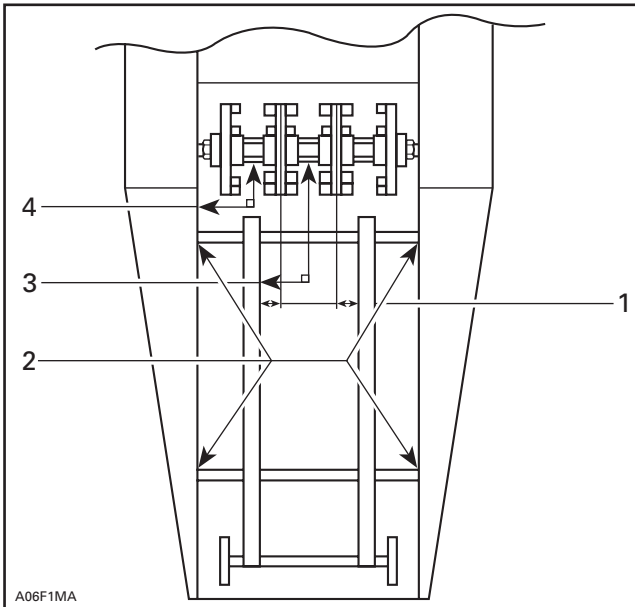

1. Align runners with drive sprockets. Equal distance both sides.
Shim drive axle to reduce end play
Maximum end play = .060" (ideal = less than .030")
2. Cut ends of tubes and shim as required to align suspension and remove freeplay
3. Suspension square with drive axle
4. Drive axle square with tunnel

Now check the axial play (side-to-side clearance) of the drive axle. The axle must not move more than 1.5 mm (.060 in) from side to side. Ideally, the axle has 0.25 – 0.50 mm (.010 – .020 in).

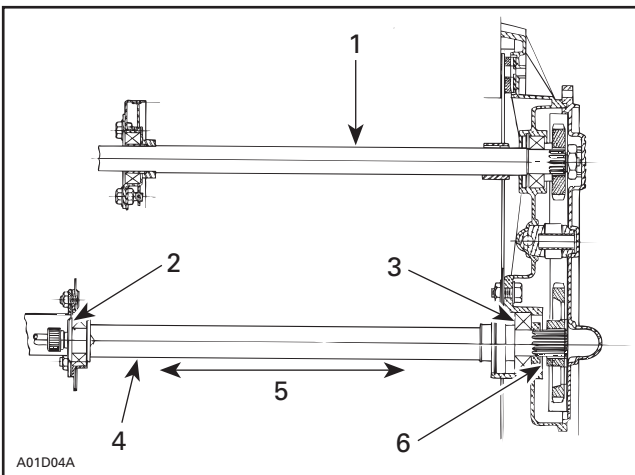

TOP VIEW

1. Countershaft
2. Shim position on end bearing housing side
3. Shim position on chaincase side
4. Drive axle
5. Axial play
6. Shim between sprocket and spacer

If the axle must be shifted left or right, note the direction and distance, and shim the axle as necessary.

Shims can be placed between the left side bearing and the end bearing housing to move the axle to the right or between the right side bearing and the chaincase to move the axle to the left.

NOTE: If shims are placed between the chaincase and the right side bearing, an equal thickness shim must be placed between the drive chain sprocket and the spacer on the axle.

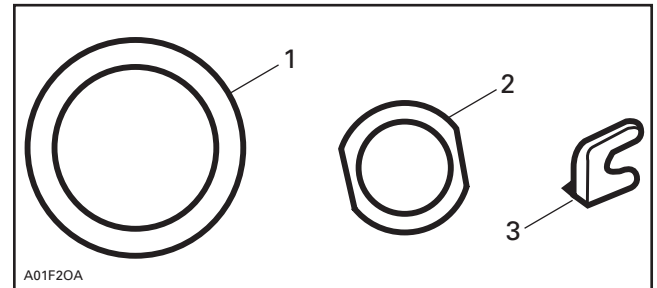

1. (P/N 501 020 500)
Shim, drive axle end bearing housing 1.6 mm (.063 in) thick
2. (P/N 506 041 400)
Shim, drive axle chaincase side 1.6 mm (.063 in) thick
3. (P/N 504 039 800)
Shim, chaincase perpendicularity 0.5 mm (.020 in) thick

Rear Axle

The idlers should be placed so that they run between the left and right double rows of drive lugs. This will help maintain alignment of the track and lessen the chance of derailing.

Use the spacing shown in the drawing.

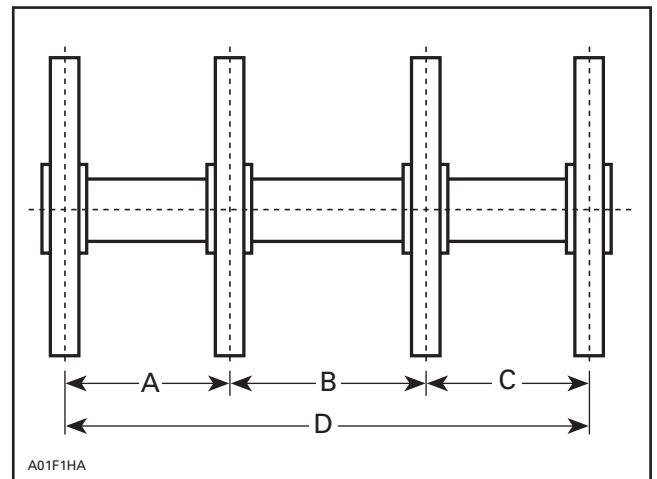

- A. 101.5 mm (3-63/64 in)
- B. 123 mm (4-27/32 in)
- C. 101.5 mm (3-63/64 in)
- D. 326 mm (12.83 in)

There are grease fittings on all moving parts of the suspension and they should be greased on a weekly basis with a quality, low temperature grease (P/N 413 711 500).

SECTION 03 - CHASSIS PREPARATION

Finally, adjust the track tension and alignment. Track tension and alignment are most critical to top speed. Make certain the track is aligned so that you have equal clearance between the slider shoe and the track guides on each side of the snowmobile.

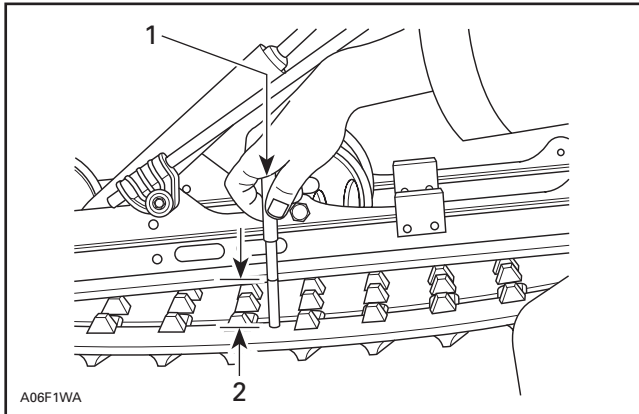

TYPICAL

1. 7.3 kg (16 lb)
2. Deflection

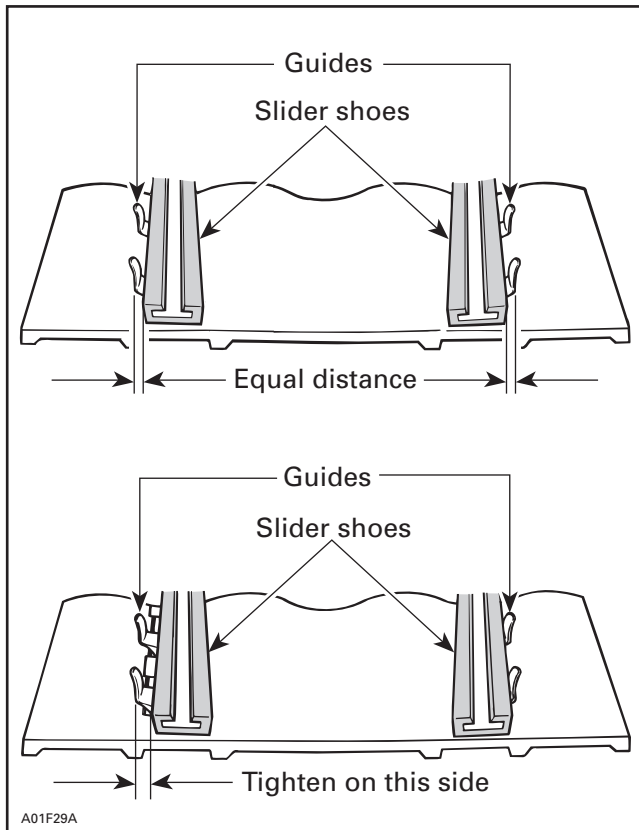

For straight line racing, top speed can sometimes be increased by running the track a bit looser. Ratcheting of the drive sprockets during hard acceleration can occur if the track is too loose. Conversely, heavily studded tracks may need to be tighter to achieve top speed because the extra weight of the studs may cause the track to **balloon out** at high speeds.

NOTE: Track tension should be checked whenever major changes are made to the limiter strap length and/or ride height changes.

BRAKES

If extreme brake use is anticipated, use 3 inch diameter dryer hose (or equivalent) to route outside air directly from the hood vents to the brake area.

SKI-DOO hydraulic brake systems use DOT 4 brake fluid. For conditions where extreme brake heat is generated, DOT 5 fluid can be used. DOT 5 has a higher boiling point but it is more susceptible to moisture intrusion and should be changed on a regular basis.

If the brakes become **spongy**, the system should be bled to remove any air bubbles. If the brake fluid is dark and/or cloudy, flush the complete system and refill with fresh brake fluid.

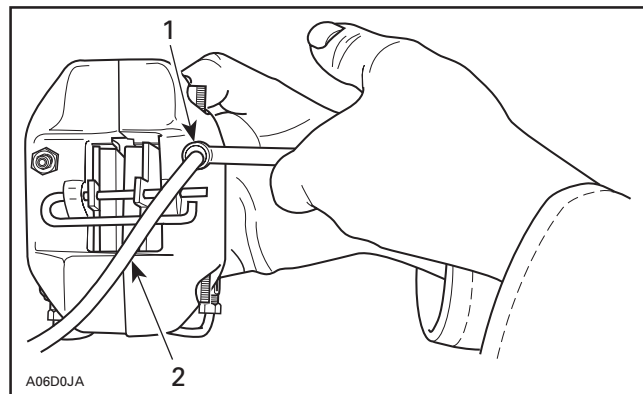

1. Hold bleeder adaptor while opening bleeder
2. Clear hose to catch used brake fluid

Pump a few time brake lever and while holding brade lever depressed, open bleeder and check for air to escape.

Repeat with the same bleeder until no air appears in hose.

ADJUSTING RIDE HEIGHT

A cross-country racer will want all the suspension travel you can for a rough snowcross-type event. But when racing a high speed event on a relatively smooth lake, giving up some of the suspension travel to lower the machine is advantageous. Lowering the machine, reducing the ride height, does 3 things for you:

1. Lowers the center of gravity of the machine; which improves cornering.
2. Reduces the frontal area of the sled; which improves aerodynamics.
3. Reduces the approach angle of the track; which reduces drag.

A person wanting to lower the machine for a short event like a radar run may simply chain or strap the machine down. Provided the course is quite smooth, this can work, but realize that strapping down the suspension preloads the springs highly and the ride will be very stiff. This technique is not recommended for most forms of racing.

The most common technique for lowering the machine is to use shorter springs or to shorten the existing springs by heating and collapsing a coil or 2 of the spring as needed. Realize that shortened springs will have very little preload when the suspension is in its "topped out" position, and it may be necessary to safety wire the spring collars into position, and use additional limiter devices like straps, chains to limit the extension of the shock.

NOTE: Some race organizations do not allow shortening springs so a proper optional short spring would be used.

Lowering the Front Suspension

Make limiter straps from standard rubber limiter strap material or link chain and go from shock bolt to shock bolt (longer shock bolts will be required). The length of the strap should be adjusted to obtain the desired ride height. Most rules require you to maintain 2 inches of suspension travel.

Shorter springs should be used to avoid excessive preload.

On vehicles with rebuildable shocks (HPG T/A), a spacer can be installed internally on the shock shaft to limit the shock extension. Spacers can be fabricated from 1 in O.D. aluminum round stock. (Refer to the shock rebuilding section for proper installation procedures).

The threaded adjusters can be loosened to provide the desired amount of spring preload.

Lowering the Rear Suspension

Option 1: The rear suspension can be lowered by compressing the rear scissors to the desired ride height and installing a strap to maintain this height. Compressing the rear scissors adds a great deal of preload to the rear torsion springs. Use softer springs.

Option 2: It is also possible to lower the rear suspension on vehicles equipped with HPG T/A shocks, by using a spacer to limit shock extension.

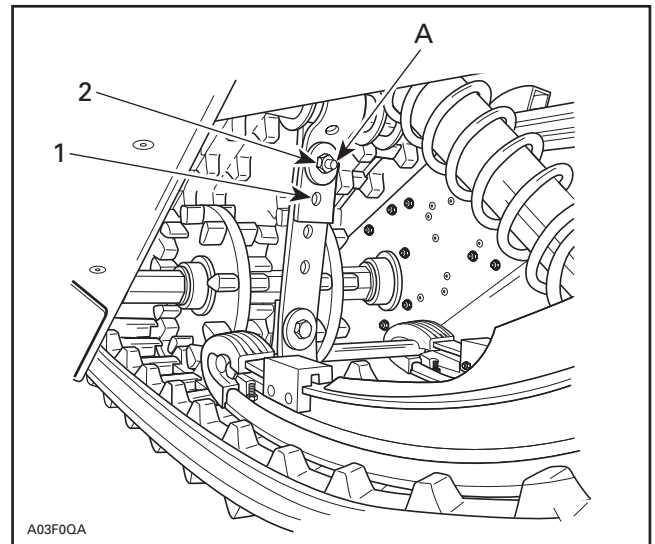

1. 1st hole
2. 2nd hole
- A. 11 N•m (97 lbf•in)

Center

Shorten the limiter strap(s) to match the ride height of the front and rear and obtain the desired amount of weight transfer. New holes can be punched in rubber limiter straps. A shorter nylon limiter strap is available for the vehicles with the strap and bolt style.

On vehicles with HPG T/A shocks the threaded adjusters can be loosened to reduce the amount of spring preload. If less preload is desired or on vehicles with cam adjusters, shorter springs may be used to reduce excessive spring preload.

SECTION 03 - CHASSIS PREPARATION

TRACK GUIDES

Additional taller track guides (P/N 486 078 200) should be installed when oval racing with a heavily studded track. These taller guides help prevent derailling without having to overly tighten the track. When in a turn, the side loads on the guides are extremely high and it is advantageous to reduce the load per guide by adding more of the guides.

All of the flat cleats should be removed from the right side of the track and replaced with guide cleats. (See drawing).

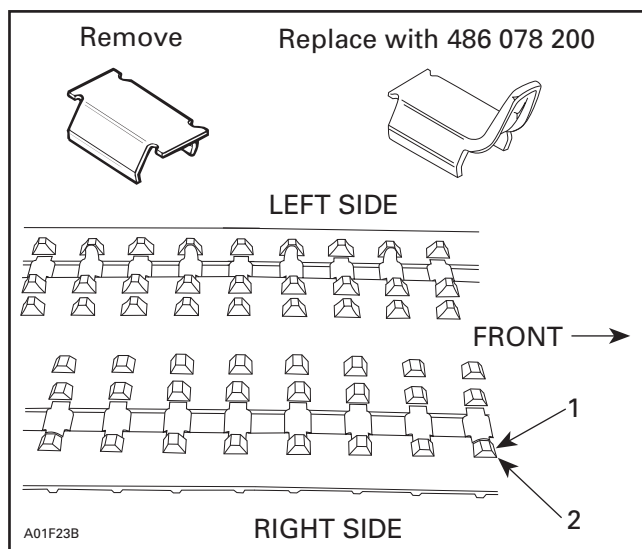

1. Standard
2. (P/N 486 078 200)

NOTE: When installing taller track guides or studs part (P/N 572 086 100), bushings should be installed inside the rear torsion springs on rear suspensions. Track guide clearance should also be checked on top of the rear suspension A.C.M.

For ice lemans type racing where left and right hand corners are encountered, extra guides should also be installed on the left side of the track.

There are two special tools which greatly enhance the removal and addition of guide clips.

(P/N 529 028 700) Guide clip remover.

(P/N 529 008 500) Guide clip crimper.

SKIS AND RUNNERS

The skis on your Ski-Doo are not flat on their bottoms, they are slightly convex. This is done to improve stability at high speed on straightaways.

The plastic ski on the MX Z X and MX Z incorporates more of its use (rocker effect). This plastic ski will work very well on snowy surfaces as it increases flotation and reduces drag. For oval and Ice Lemans, the new profile is superior to the steel ski.

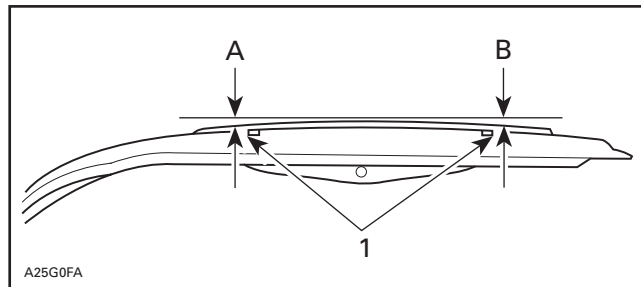

1. The above illustration is an example of what is called rocker
- A. 2 mm (3/32 in)
B. 2 mm (3/32 in)

Check your skis from time to time to confirm the 2 mm (3/32 in) (measured at the ski runner studs) bow. If the skis have flattened, use a hydraulic press as necessary to restore the original shape. This is most important for oval racers.

Plastic skis or liners are good for a 2 MPH increase in speed in most snow conditions, more in sticky snow conditions.

Carbide inserted ski runners are necessary for all forms of racing except drag racing and radar runs. The type of racing you are involved in and the condition of the track will determine what style of carbide and how much carbide you will be using.

For the ice race track, special flat-backed race runners with 60° carbide inserts are a must. The flat back of the runner helps to keep the runner from being rolled over by cornering forces. The best racing runners are heat-treated to prevent them from bending under high side loads.

When installing carbide inserts, start with 100 mm (4 in) of carbide in front of a line projected from the center line of the ski leg and 125 mm (5 in) behind the line. Always keep the amount of carbide behind the line longer than in front.

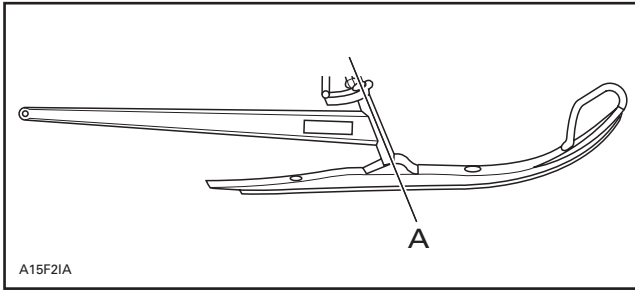

A. 122 mm (5 in) 98 mm (4 in)
 147 mm (6 in) 171 mm (7 in)

The condition of the skis and runners, as well as their alignment, has an effect on top speed. The ski toe-out must be correct; any irregularities in the skis should be removed, and bent or badly worn runners must be replaced.

CAUTION: The amount of carbide allowed on each runner may be limited by your race association. Check your rule book.

BUMP STEER

Bump steer refers to the amount of change in the toe-out of the skis as the suspension moves through its total vertical travel. Block up the machine so that the skis are just off the ground and remove the springs from the shocks. This will allow you to cycle the suspension and measure the bump steer on your vehicle.

You will need a reference point to measure to as you cycle the suspension through its travel. Because you will be lifting the ski and suspension assemblies as you are measuring, you should use a reference point that is not easily bumped out of position. A pair of concrete blocks set on a line about 50 mm (2 inches) away from the edge of the ski and parallel to the ski works nicely.

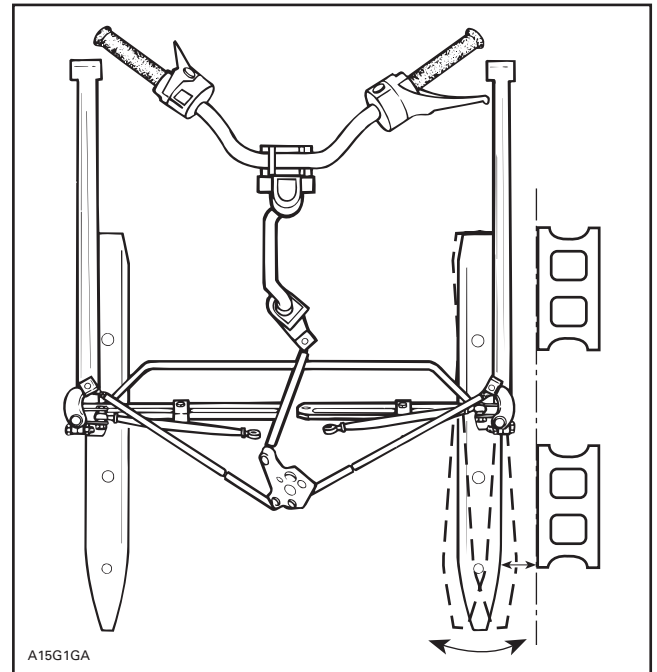

Lift the ski up to its upper travel limit. Using a measuring tape, measure the distances from the front and rear edges of the ski to the concrete block reference. The front and rear measurements must be equal or no more than 1.6 mm (1/16 in) difference if the bump steer adjustment is correct.

SKI LEG CAMBER

The camber angle of the ski legs changes how aggressively the ski runners hook up with the driving surface. Adding negative camber will have the most effect on handling. This is because the weight shift in a turn is always to the outside of the turn and the negative camber of the ski leg causes the wear bar to be presented to the driving surface in a more aggressive position. Positive camber will tuck the wear bar in toward the sled, thereby reducing its traction in a turn.

Camber adjustments do have an effect on the width of the machine. Make certain your camber adjustments do not push you beyond the overall width limit imposed in most forms of racing.

Camber is the tilting of the ski leg from the vertical. To obtain a negative camber angle, the ski leg must be tilted inward so that the ski legs are closer together at the top than at the bottom. Positive camber would tilt the top of the ski leg away from the machine. Camber angle is measured in degrees from the vertical and must be noted as positive or negative.

SECTION 03 - CHASSIS PREPARATION

Most oval racers set the left ski leg at 0° camber and the right at - 3° to - 5° camber. Trail riders and drag racers should set both ski legs at 0° camber while cross-country and snowcross riders most often set up both ski legs with - 1° to - 3° camber.

Camber angle is measured using an angle finder available from most tool supply stores.

Adjustment is performed by adjusting the length of the upper control arm.

2004 MX Z X 440 REV Front Suspension Settings

The ski springs rate is 18.39 N/mm (105 lbs/in) (P/N 505 071 201). The spring must be preloaded by 10 mm (3/8 in) at full extension. Attention, the front spring must always have a minimum preload of 3 mm (1/8 in) and a maximum preload of 25 mm (1 in). Always set the spring preload with a fully extended suspension. For a softer spring, the (P/N 486 130 023) 15.76 N/mm (90 lbs/in) will fit on the production shock. For a stiffer set-up, use (P/N 486 130 024) 21.01 N/mm (120 lbs/in).

The front suspension have 251 mm (9.9 in) of travel, 4.94° negative camber at full extension, 2° negative camber fully compressed. The toe must be 3 mm (1/8 in) open, no bump steer, 13 mm (1/2 in) of scrub at the worst condition.

The ski leg comes with a pilot hole for ice racing purpose. (See picture below)

The side of the ski leg is machined at 2° angle. To measure your camber, add this 2° to your measure.

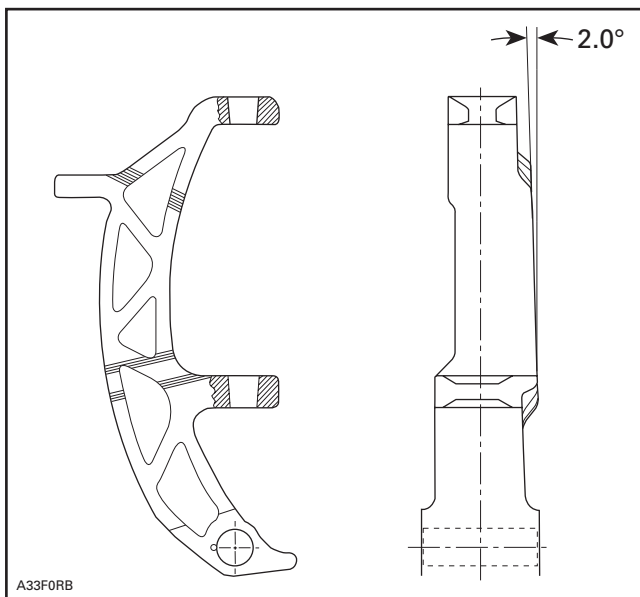

SKI TOE-OUT

Most oval racers use modified handlebars with loops or angles on the left end. Often a driver prefers a handlebar position that is not horizontal when the skis are in their straight ahead position. This allows a more comfortable driving position when in a corner. Whatever handlebar you prefer should be positioned as you prefer it when going down a straightaway before you begin your toe-out adjustment.

Use a rubber cord stretched between the ski tips to keep constant pressure on the steering system while measuring toe-out. Measure the distance between the inner edges of the skis as far back and as far forward on the skis as possible. Avoid measuring at a point at the top or heel of the ski where the ski is tapered. With aggressive race carbide, the measurements should be taken at the front and back of the runners on the cutting edge for the most precise measurement.

Skis must have a toe-out of 3 to 6 mm (1/8 to 1/4 in) when they are in the straight ahead position.

Adjustment is performed by loosening the lock nuts on the ball joints at the ends of the left and right tie rods. Rotate tie rods as necessary to achieve the proper toe-out and handlebar position. Do not use the short tie rod that runs beneath the engine to adjust ski toe-out.

Never lengthen a tie rod so that the threaded portion of the ball joint extends over 17 mm (11/16 in) beyond the tie rod. To avoid this, distribute the adjustment requirements equally to both left and right tie rods.

Retorque ball joint lock nuts to 29 N•m (21 lbf•ft) when toe-out is correct.

With the aggressive setup of the front end necessary for competitive oval racing, it is important to keep all the steering system components tight and free of play. Worn ball joints and bushings should be replaced, bolts holding the skis to the ski leg must be tight and wear bars must be straight and bolted securely to the skis. Any play in the steering will result in severe chattering in the corners and darting on the straightaways.

CHASSIS TUNING GUIDELINES

How to Deal with Handling Problems

There is usually never one adjustment that will correct a certain handling quirk. You will usually end up with several changes in setup to achieve the same goal. There are certain basics to keep in mind, however, when you are working with your sled:

- Handling problems encountered when entering a corner are usually corrected by working with front end adjustments.
- Handling problems encountered when exiting a corner are usually corrected by working with rear suspension adjustments.
- Basic handling problems are often traced to improper suspension adjustments.

Guide to Handling Problems

NOTE: PUSHING refers to the front of a vehicle not steering as much as the driver wants. The skis are not grabbing the surface with sufficient force. LOOSE refers to the rear of a vehicle sliding outward in a turn. The track is not grabbing the surface with sufficient force.

NOTE: Center spring/shock refers to the front arm of the rear suspension.

1. Problems encountered when entering a corner.
 - a. Front end pushes coming into a corner (steering is not precise).
 - Sharpen carbide runners.
 - Add more carbide.
 - Shorten limiter strap on center arm.
 - Increase negative camber of ski legs.
 - Increase ski spring preload.
 - Decrease center spring preload.
 - b. Rear of machine starts to come around or is loose when entering a corner.
 - Lengthen limiter strap on center arm.
 - Decrease ski spring preload.
 - Decrease negative camber of ski legs.
 - Increase center spring preload.
 - Sharpen/add track studs.
- c. Inside ski lifts.
 - Reduce the amount of negative camber on the ski legs.
 - Check for free operation of stabilizer bar.
 - Decrease preload of ski springs.
 - Shorten limiter strap on center arm.
2. Problems encountered while going around or exiting a corner.
 - a. Front end pushes coming out of corner (steering is not precise).
 - Shorten limiter strap on center arm.
 - Decrease center spring preload.
 - Check condition of carbides.
 - Add more carbide.
 - Increase negative camber of ski legs.
 - Increase ski spring preload.
 - Increase rear spring preload.
 - Tighten A.C.M.
 - Increase rear to front coupling.
 - b. Rear of machine starts to come around or is loose when exiting a corner.
 - Lengthen limiter strap on center arm.
 - Decrease ski spring preload.
 - Increase center spring preload.
 - Decrease negative camber of ski legs.
 - Decrease rear spring preload.
 - Loosen A.C.M.
 - Decrease rear to front coupling.
 - c. Left ski lifts.
 - Shorten limiter strap on center arm.
 - Decrease center spring preload.
 - Check for free operation of stabilizer bar.
 - Increase stabilizer bar diameter or shorten end levers.
3. General handling problems.
 - a. Machine darts from side to side on straight-away.
 - Check ski toe-out.
 - Check for loose ball joints in steering.
 - Too much negative ski leg camber.
 - b. Excess effort required to turn handlebars.

SECTION 03 - CHASSIS PREPARATION

- Check steering linkages for binding and/or corrosion.
 - Rubber blocks between skis and ski legs have too much preload at the rear (causing rear of skis to be pushed down too much).
 - Lengthen limiter strap on center arm.
 - Increase center spring preload.
 - Decrease ski spring preload.
 - Too much carbide on ski runners.
4. Adjusting the suspension for ride and comfort.
- a. The rear springs of the rear suspension should be adjusted as follows:
- Fully extend the rear suspension.
 - Measure from the floor to the bottom of the rear grab handle (remember this dimension).
 - Load the vehicle as it will be used (1 or 2 people, saddlebags full of equipment, etc.).
 - Again, measure from the floor to the bottom of the rear grab handle. This dimension should be 25 mm to 50 mm (1 in to 2 in) less than the fully extended dimension.
 - If the vehicle settles more than 50 mm (2 in), increase the rear spring preload.
 - If the vehicle settles less than 25 mm (1 in), decrease the rear spring preload.
 - This is a preliminary setting only! Increase and decrease the preload adjustments to fine tune for your preference.
 - The center spring and ski springs will have the most affect on handling, but if the preload is too stiff, it will produce a harsh ride.

General Tips

If the spring and preload combination you are using exerts the right amount of pressure at full compression but has too much force at initial compression, try a shorter, stiffer spring. The shorter spring will not be preloaded as much and will “act” softer during initial compression, but will get stiffer as the suspension compresses. Conversely, if a set-up is good at initial compression but too stiff at full compression, then a softer spring would be used. The following chart can be used to determine how much force a spring and preload combination will exert during compression.

TABLE OF CONTENTS

| | |
|---|--------------|
| ENGINE TUNING CAUTIONS | 04-3 |
| BASIC ENGINE THEORY | 04-3 |
| OPERATION OF THE RAVE VALVE | 04-6 |
| CARBURETION | 04-9 |
| MIKUNI VM AND TM TYPE CARBURETORS | 04-13 |
| TM 40 CARBURETORS | 04-13 |
| IGNITION SYSTEMS, SPARK PLUGS | 04-28 |
| 593 HO AND 793 HO ENGINE TYPES | 04-31 |
| MAINTENANCE | 04-32 |
| REMOVAL FROM VEHICLE | 04-32 |
| INSTALLATION | 04-32 |
| INSTALLATION ON VEHICLE | 04-33 |
| TOP END | 04-34 |
| TROUBLESHOOTING | 04-35 |
| COMPONENT REMOVAL WITH THE ENGINE INSTALLED | 04-35 |
| CLEANING | 04-35 |
| DISASSEMBLY | 04-35 |
| INSPECTION | 04-37 |
| ASSEMBLY | 04-38 |
| BOTTOM END | 04-42 |
| CLEANING | 04-43 |
| DISASSEMBLY | 04-43 |
| INSPECTION | 04-43 |
| ASSEMBLY | 04-43 |
| BREAK-IN | 04-45 |
| PREPARATION | 04-46 |
| PROCEDURE | 04-46 |
| FINALIZING REASSEMBLY | 04-48 |
| ENGINE LEAK VERIFICATION FLOW CHART | 04-49 |
| ENGINE DIMENSION MEASUREMENT | 04-50 |
| CYLINDER HEAD WARPAGE | 04-50 |
| CYLINDER TAPER | 04-50 |
| CYLINDER OUT OF ROUND | 04-50 |
| COMBUSTION CHAMBER VOLUME MEASUREMENT | 04-51 |
| USED PISTON MEASUREMENT | 04-52 |
| CYLINDER/PISTON CLEARANCE | 04-52 |
| RING/PISTON GROOVE CLEARANCE | 04-54 |
| RING END GAP | 04-54 |
| CRANKSHAFT DEFLECTION | 04-54 |
| CONNECTING ROD BIG END AXIAL PLAY | 04-55 |
| CRANKSHAFT END-PLAY | 04-55 |
| CHECKING CRANKSHAFT ALIGNMENT | 04-55 |

SECTION 04 - ENGINE PREPARATION

- DENSO TRIGGER COIL IGNITION SYSTEM 04-56**
- CLEANING 04-57
- DISASSEMBLY 04-57
- ASSEMBLY 04-58
- OIL TYPE 04-60
- OIL SYSTEM LEAK TEST 04-60
- OIL PUMP IDENTIFICATION 04-60
- CLEANING 04-60
- REMOVAL 04-60
- INSTALLATION 04-60
- ADJUSTMENT 04-61
- CHECKING OPERATION 04-62
- COOLING SYSTEM LEAK TEST 04-64
- INSPECTION 04-64
- DRAINING THE SYSTEM 04-64
- DISASSEMBLY AND ASSEMBLY 04-64
- COOLING SYSTEM REFILLING PROCEDURE 04-65
- INSPECTION 04-68
- REMOVAL 04-68
- ROPE REPLACEMENT 04-68
- DISASSEMBLY 04-68
- ASSEMBLY 04-69
- INSTALLATION 04-71

ENGINE TUNING CAUTIONS

Here are a few items to keep in mind when working with your engine.

If you are in stock classes, know what adjustments are legal.

Modifications to the power curve of an engine will require recalibration of the transmission.

The lower the RPM at which you can generate the torque you need, the higher the percentage of that power that will reach the track.

Sloppy engine modification usually results in less power than you had stock.

Use the proper octane gasoline for your engine (Modification may require higher octane.).

Correct your carburetor jetting for the atmospheric conditions which exist at the time as close as possible to the time you will be competing.

Follow the assembly and disassembly procedures outlined in the appropriate *Shop Manual*.

BASIC ENGINE THEORY

Terminology

| | |
|---|---|
| CYCLE | In a combustion engine, a cycle is accomplished when the four (4) phases; intake, compression, ignition and exhaust are complete. |
| TDC | Top Dead Center: The position of the piston when it reaches the upper limit of its travel inside the cylinder. BTDC: Before Top Dead Center ATDC: After Top Dead Center |
| BDC | Bottom Dead Center: The position of the piston when it reaches the lower limit of its travel inside the cylinder. BBDC: Before Bottom Dead Center ABDC: After Bottom Dead Center |
| BORE | Diameter of the cylinder. |
| STROKE | The maximum movement of the piston from BDC to TDC. It is characterized by 180° of crankshaft rotation. |
| COMBUSTION CHAMBER | Space between cylinder head and piston dome at TDC. |
| DISPLACEMENT | The volume of the cylinder displaced by the piston as it travels from TDC to BDC. The formula is: $\frac{\text{Bore}^2 \times \text{Stroke} \times \pi}{4} \times 20$ = (π = 3.1416) Expressed in cc (cubic centimeters) |
| NOTE: To transfer cc to cubic inches, divide cc by 16.387. | |
| COMPRESSION | Reduction in volume or squeezing of a gas. |

SECTION 04 - ENGINE PREPARATION

Combustion Process

NORMAL COMBUSTION

Since the beginning of this study we have spoken of air/fuel mixture combustion rather than explosion. This combustion is a slow then accelerated burning of the mixture within the combustion chamber. Ignition occurs with the firing of the spark plug.

This initial process generates heat and pressure which in turn, is transmitted by conduction to the contiguous portion of the unburned mixture. When this portion has reached the point of self-ignition it starts to burn releasing more pressure and heat.

This burning action, called a flame front, travels at a speed of approximately 30.3 m (100 feet) per second until all mixture is burned, thus providing maximum piston thrust.

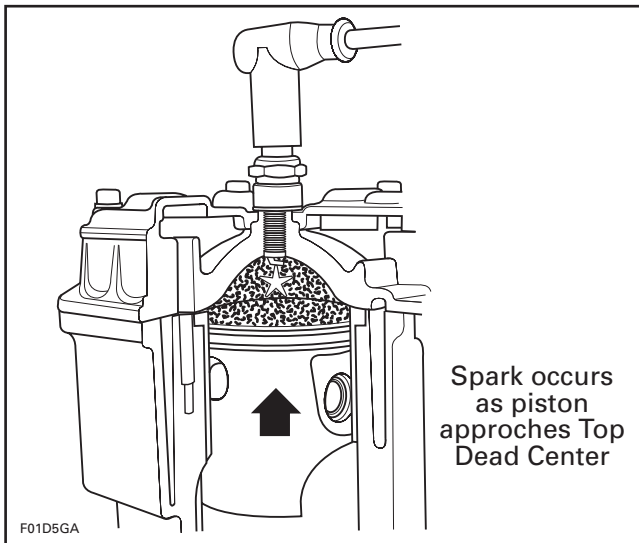
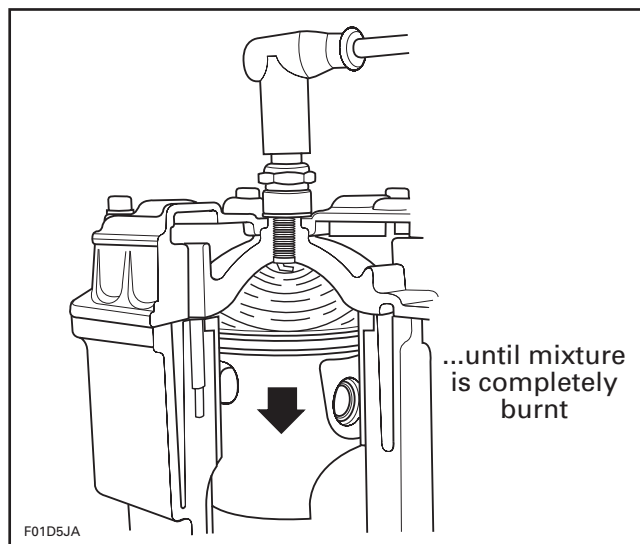
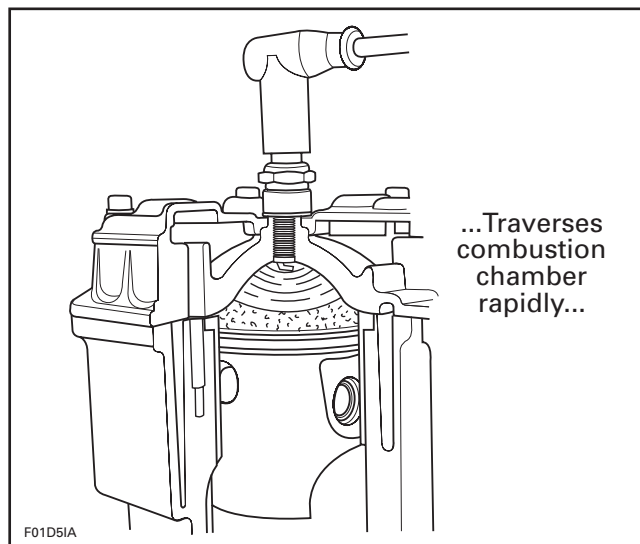
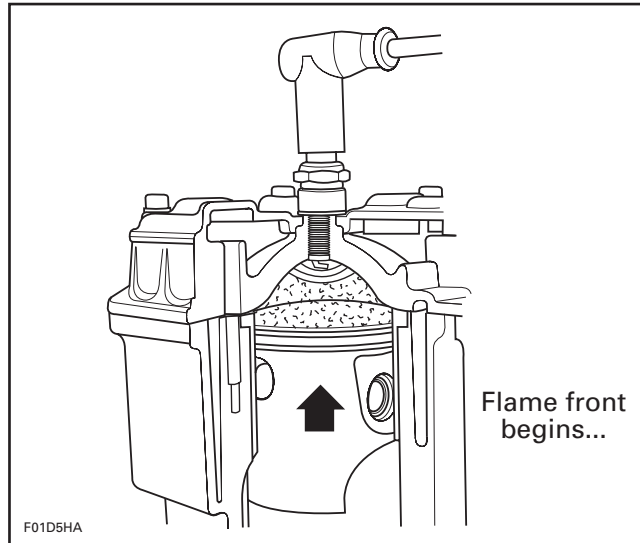

With all operating parameters correct, normal combustion will take place. However, if for some reason the temperature inside the cylinder is increased during combustion, abnormal combustion will occur and lead to serious engine damage.

DETONATION

In detonation, the spark plug initiates burning and the air/fuel mixture starts to burn in the usual manner but as combustion continues, the heat generated affects the large portion of the yet unburned air/fuel mixture.

This unburned mixture temperature becomes so high that it burns spontaneously creating high-velocity pressure waves within the combustion chamber.

These shock waves can sometimes be heard as pinging. While these shock waves can be detrimental to the mechanical integrity of the engine, it is the excessive heat that causes most problems in 2-strokes. The piston may expand excessively causing a seizure or the piston may melt. The melting will occur at the hottest points, which will be right below the spark plug and around the edge of the piston — often at a ring locating pin. If allowed to continue, a hole may melt completely through the top of the piston.

PRE-IGNITION

Pre-ignition is the ignition of the mixture inside the combustion chamber before the timed spark. Pre-ignition sources are generally an overheated spark plug tip or a glowing carbon deposit on the piston head. Since ignition occurs earlier than the timed spark, the hot gases stay longer in the combustion chamber, thus increasing cylinder head and piston temperatures to a dangerous level.

Usually the piston is subject to damage. It may seize or the aluminum on the exhaust side of the piston dome may melt. Pre-ignition is always preceded by detonation.

CAUSES OF DETONATION:

Octane of the fuel is too low.

Air/fuel mixture is too lean.

- a. Incorrect jetting.
- b. Air leaks.
- c. Varnish deposits in carburetor.
- d. Malfunction anywhere in fuel system.

Spark plug heat range too high.

Ignition timing too far advanced.

- a. Initial timing incorrect.
- b. Ignition component failure.

Compression ratio too high.

- a. Improperly modified engine.
- b. Deposit accumulation on piston dome or head.

Exhaust system restrictions.

- a. Muffler plugged/restricted.
- b. Tail pipe diameter too small.
- c. Incorrect design of expansion chamber.

General overheating.

- a. Broken fan belt.
- b. Loss of coolant.
- c. Lack of snow on heat exchangers.

Coolant or water entering combustion chamber.

SQUISH AREA

Rotax cylinder heads incorporate a squish area. This area is basically a **ledge** projecting beyond the combustion chamber area. In operation, as the piston ascends and approaches the ledge, a rapid squeezing action is applied to the air/fuel mixture contained in the area immediately between the piston dome and the ledge. This squashing action forces the entrapped mixture rapidly into the combustion chamber area, creating a greater mixture turbulence. Additionally, the small volume and large surface area of the squish band allow a better cooling of the end gases to help prevent detonation.

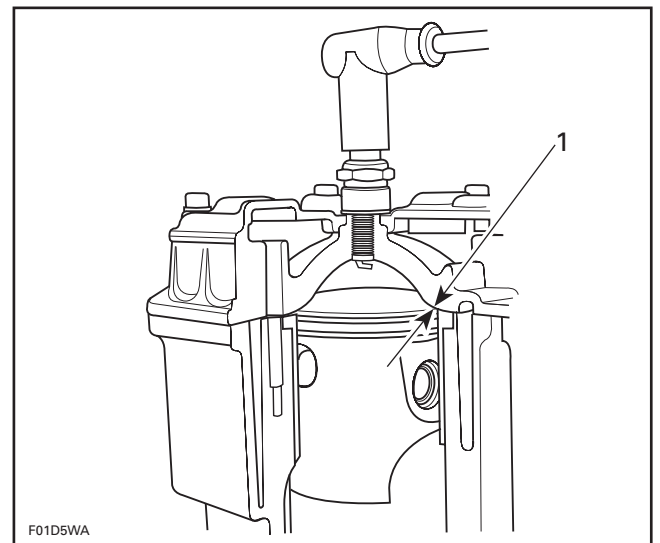

1. Squish area

SECTION 04 - ENGINE PREPARATION

If the squish clearance is increased, a loss in power will occur while too small a squish clearance will lead to detonation.

The squish clearance can be measured by inserting a piece of rosin core solder into the combustion chamber, rotating the engine through TDC, removing the solder and measuring the thickness of the compressed solder.

The solder should be inserted above and in line with the wrist pin. Measure the squish on both sides of piston as it may vary from side to side.

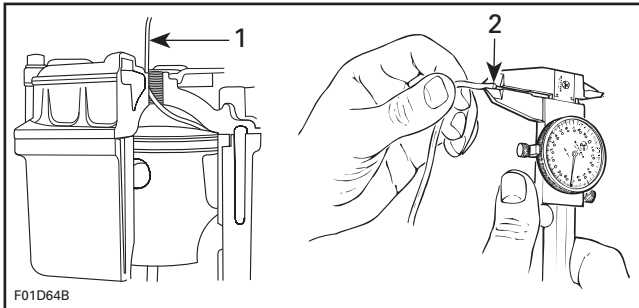

1. Solder
2. Flattened area

CAUTION: Do not use acid core solder; the acid can damage the piston and cylinder.

OPERATION OF THE RAVE VALVE

NOTE: Rave stands for Rotax Adjustable Variable Exhaust.

Theory

For a two-stroke-cycle engine to have high power capacity at high crankshaft speeds, a high volumetric or breathing efficiency is required and the fresh charge losses must be minimized. The result is achieved by opening the exhaust port early (94.5° BBDC) and utilizing the resonant effects of the tuned exhaust system to control fresh charge losses.

When an engine of this design is run at a medium speed, efficiency falls off quickly. The relatively high exhaust port effectively shortens the useful power stroke and because the exhaust system is tuned for maximum power, there is a large increase of fresh charge losses. As a result, the torque decreases along with a dramatic increase of the specific fuel consumption. Higher torque along with lower fuel consumption can be obtained at lower engine speeds if the time the exhaust port is open is shortened.

BOMBARDIER-ROTAX has patented a remarkably simple system to automatically change the exhaust port height based on pressure in the exhaust system.

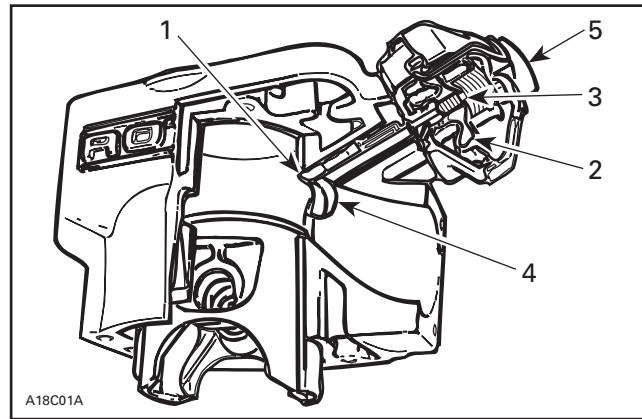

1. Guillotine
2. Diaphragm
3. Return spring
4. Exhaust port
5. Red plastic adjustment knob

Located above the exhaust port is a guillotine-type slide valve (item 1). This rectangular valve is connected by a shaft to a diaphragm (item 2) which is working against the return spring (item 3). Two small passages in the cylinder just outside the exhaust port (item 4) allow exhaust gas pressure to reach the diaphragm. As the throttle is opened and the engine begins producing more power, the pressure against the diaphragm will overcome the pressure of the return spring and the RAVE valve will open.

To the outside of the return spring is a red plastic adjustment knob (item 5). Turning the adjustment in or out changes the preload on the return spring which, in turn, will change the RPM at which the RAVE valve opens and closes. The exhaust port height changes a total of 4 mm to 6 mm (depending on engine type) from the RAVE valve fully closed to fully open.

Operation

The RAVE valve does not allow an engine to make higher peak horsepower than an engine not so equipped, it can make moving the peak higher practical because of its effect on the rest of the power curve. Item 2 in following illustration is the power curve of an engine with the RAVE valve held fully open through its entire RPM range. Item 6 notes the peak power produced. That peak will not change if the exhaust port time of a similar engine without a RAVE valve was the same (with all other features equal).

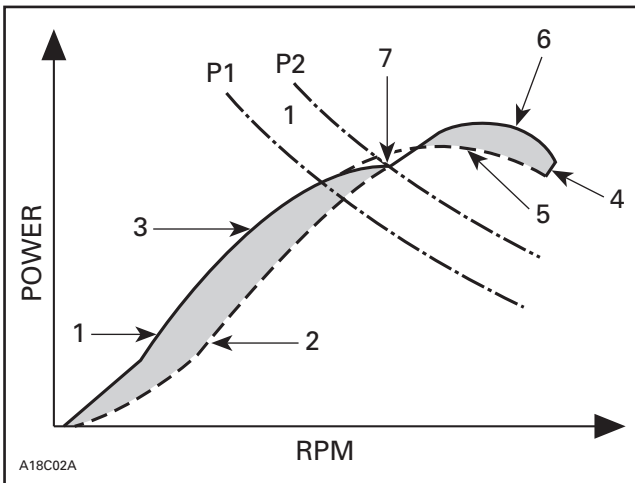

Item 1 is the power curve of the engine with the RAVE closed through its entire RPM range. The shaded area (item 3) is the improvement in power at lower engine speeds that is gained because of the lower exhaust port. If the port remains at this height, however, the power would peak as noted in item 5. Raising the exhaust port at the proper RPM (item 7) will allow the engines peak power to continue to rise to item 6.

Item P1 in the illustration is the pressure of the return spring against the diaphragm. The exhaust pressure must be high enough to overcome this pressure before the valve begins opening. Item P2 is the pressure required to completely open the RAVE valve. Between P1 and P2, the usable power curve of the engine is moving from power curve 1 to power curve 2. This transition takes place very rapidly at full throttle and from a practical standpoint can be considered to be instantaneous at item 7 which for the type 583 engine is at 6300 - 6400 RPM. Gradual application of the throttle, however, will result in the RAVE valve opening much later, i.e. 7300 - 7500 RPM.

If the RAVE valve opens too late, the engine will bog or hesitate momentarily as the RPM increases. Full peak performance (item 6) is still available. From a functional point of view, it is better to have the valve open a bit early than a bit late. This fact is due to certain dynamic conditions that exist on the snowmobile, i.e., the clutch and torque converter.

Adjustment

The red cap on the RAVE valve cover should be turned all the way in and bottomed in normal use. Backing the red adjuster out will reduce the spring preload and allow the RAVE valve to open at a lower RPM.

At high altitudes, exhaust gas pressures will drop and the spring preload may have to be decreased. It is doubtful that any adjustment will be required up to an altitude of 2400 m (8000 ft). Above that, however, the spring preload can be reduced by turning the red adjustment screw out up to a maximum of four turns.

The only other time adjustment of the spring preload should be considered is if the engine has been modified in any way.

AVAILABLE RAVE SPRINGS

| Spring P/N | Wire Dia. mm (in) | Free Length mm (in) | Preload in N (LBF) at Compressed Length of 14 mm (.551 in) |
|-------------|----------------------|------------------------|--|
| 420 239 948 | 1.0 (.039) | 38.0 (1.50) | 19.5 (4.37) |
| 420 239 944 | 0.9 (.035) | 48.5 (1.91) | 15.9 (3.56) |
| 420 239 942 | 0.8 (.031) | 42.5 (1.67) | 7.3 (1.64) |
| 420 239 941 | 0.8 (.031) | 52.5 (2.07) | 10.5 (2.36) |

Maintenance

There are no wear parts anywhere in the system and there are no adjustments to be periodically checked. The only possible maintenance required would be cleaning of carbon deposits from the guillotine slide. Cleaning intervals would depend upon the user's riding style and the quality of the oil used. Using Ski-Doo oil, we would suggest annual cleaning of the valve. If a customer uses a lower quality, high ash oil, more frequent cleaning may be required.

No special solvents or cleaners are required when cleaning the valve.

SECTION 04 - ENGINE PREPARATION

Bench Test for Checking RAVE Valve Operation

The operation of the valve can be checked by pressurizing the engine as one would when checking for crankcase leaks.

The engine must be sealed at all exhaust flanges, all carburetor inlets, and at the fuel pump impulse fitting. Depending on the design of your pressure test kit, you may be pressurizing the engine through the crankcase or right at the exhaust flange cover plate. If you are pressurizing through the crankcase, make certain the piston uncovers the exhaust port on the side you are checking.

Install the RAVE valve movement indicator (P/N 861 725 800) in place of the red plastic adjuster on the diaphragm cover so that you can observe the diaphragm movement.

The movement indicator must be turned all the way in to provide maximum spring pre-load. As you begin pressurizing the engine using engine leak tester kit (P/N 861 749 100), you will find the RAVE valve beginning to move at 5 kPa (0.7 PSI or 20 inches of water) and the valve will be fully displaced when you reach 10 kPa (1.4 PSI or 40 inches of water).

NOTE: Due to the low pressure conditions when using the leak tester kit (P/N 861 749 100) to check the RAVE valve operation, install a gauge with a range of 0-200 inches of water (P/N 861 749 100) on leak tester. As reference 6.89 kPa 1 (PSI) = 27.71 inches of water.

Troubleshooting

| SYMPTOM | CAUSE | REMEDY |
|---|------------------------------------|-----------------------|
| Engine revs 500 to 1000 RPM lower than its maximum operational RPM; Rave valve is not opening. | 1. Bent valve rod | Replace |
| | 2. Stuck valve | Clean |
| | 3. Wrong spring tension (too high) | Replace |
| | 4. Clogged passages | Clean |
| | 5. Damaged bellows or clamp(s) | Replace |
| Engine hesitation in mid RPM range and full peak performance is available only after a while. Rave valve opens too early. | 1. Broken or weak spring | Replace |
| | 2. Adjustment screw too far out | Turn until it bottoms |
| | 3. Valve stuck open | Clean |

SKI-DOO utilizes cylinder reed induction technology on the new Series 3 twin cylinder engines. This technology is beneficial in three ways.

1. It uses less parts, (i.e. shafts, rotary valve discs, etc.). Resulting in a lighten engine package.
2. This technology results in positive control of fuel mixture, while providing a straight pathway to the intake and transfer ports as it is not obstructed by the rotating crankshaft.
3. By locating the carburetors higher on the engine this design allows for lower engine placement in the chassis.

SECTION 04 - ENGINE PREPARATION

| BASE GASKETS | | |
|--------------|-----------------|--------|
| 453 | P/N 420 931 580 | 0.3 mm |
| | P/N 420 931 581 | 0.4 mm |
| | P/N 420 931 583 | 0.5 mm |
| | P/N 420 931 582 | 0.6 mm |
| | P/N 420 931 584 | 0.8 mm |
| 493 | P/N 420 931 588 | 0.5 mm |
| | P/N 420 931 589 | 0.8 mm |
| | P/N 420 931 960 | 0.7 mm |
| | P/N 420 931 587 | 0.6 mm |
| 593 | P/N 420 931 582 | 0.6 mm |
| | P/N 420 931 962 | 0.7 mm |
| | P/N 420 931 583 | 0.5 mm |
| | P/N 420 931 584 | 0.8 mm |
| 693 | P/N 420 931 892 | 0.6 mm |
| | P/N 420 931 893 | 0.5 mm |
| | P/N 420 931 894 | 0.7 mm |
| | P/N 420 931 895 | 0.8 mm |
| 793 | P/N 420 931 838 | 0.5 mm |
| | P/N 420 931 837 | 0.6 mm |
| | P/N 420 931 964 | 0.7 mm |
| | P/N 420 931 839 | 0.8 mm |

CARBURETION

Carburetor Main Jet Correction Chart

| CARBURETOR MAIN JET CORRECTION CHART | | | | | | | | |
|---|-------------|-------------|-------------|------------|------------|------------|-------------|-------------|
|  | | | | | | | | |
| FT/METER | °F/°C | | | | | | | |
| | -60/ -50 | -40/ -40 | -20/ -30 | -0/ -20 | +20/ -5 | +40/ -5 | +60/ -15 | +80/ -25 |
| 0 | 111.10 | 107.40 | 103.70 | 100.00 | 96.30 | 92.60 | 88.90 | 85.20 |
| 2000/ 600 | 105.77 | 102.07 | 98.37 | 94.67 | 90.97 | 87.27 | 83.57 | 79.87 |
| 4000/ 1200 | 100.43 | 96.73 | 93.03 | 89.33 | 85.63 | 81.93 | 78.23 | 74.53 |
| 6000/ 1800 | 95.10 | 91.40 | 87.70 | 84.00 | 80.30 | 76.60 | 72.90 | 69.20 |
| 8000/ 2400 | 89.7 | 86.07 | 82.37 | 78.67 | 74.97 | 71.27 | 67.57 | 63.27 |
| 1000/ 3000 | 84.44 | 80.74 | 77.04 | 73.34 | 69.64 | 65.94 | 62.24 | 58.54 |

A01C47A

NOTE: When the answer gives an unavailable jet size, select the next highest (richer) jet.

Example:

With a 250 stock main jet, at an altitude of a 600 m (2000 ft) and a temperature of - 5°C (20°F):

$$250 \times \frac{90.97}{100} = 227; \text{ use } 230 \text{ jet.}$$

CAUTION: These values are guidelines only. Specific values/adjustments vary with temperature, altitude and snow conditions. Always observe spark plug condition for proper jetting.

This table is more than adequate for stock engines. Two-stroke engines with high specific outputs that are heavily modified (twin pipes, high compression, large carburetors, etc.) and performing at high RPM are very sensitive to air density changes. The following is a very accurate formula for correcting jetting.

First, a baseline for jetting must be established.

SECTION 04 - ENGINE PREPARATION

Jetting, horsepower, and B.S.F.C. data can be obtained with dyno testing but also confirmed with field testing. The tried and true method of determining mixture ratio is to inspect the parts of the engine that are directly exposed to the combustion process. The two best indicators are the spark plug and the piston dome. The color and where it is located are the two things to look for. Chocolate brown on the insulator, ground electrode, and piston dome indicate a proper mixture. The ground electrode should show a difference in color just at the radius of the electrode.

The engine must be operated under load for at least one minute to obtain accurate readings.

Establish the C.R.A.D. by using the following formula:

$$\text{C.R.A.D.} = \frac{1737.97 \times \text{C.A.P.}}{460 + T}$$

C.A.P. = Corrected air pressure

C.A.P. = B - E

B = Barometric pressure readings (in - Hg)

E = Vapor pressure = $\left(\text{S.P.} \times \frac{\text{R.H.}}{100} \right)$

See saturation pressure (chart 1).

S.P. = Saturation pressure (in - Hg)

R.H. = Relative humidity (%)

Record the C.R.A.D. when correct jetting has been established. This is your base line for future use.

Example: Testing established a 400 main jet at C.R.A.D. of 100%. One week later, the C.R.A.D. at the track is 110%. Use the following formula to establish the new main jet.

$$\text{New main jet} = \frac{\text{New C.R.A.D.} \times \text{Baseline main jet}}{\text{Base line C.R.A.D.}}$$

Example: $\frac{110 \times 400}{100}$

New main jet = 440

Record the C.R.A.D. when correct jetting has been established. This is the baseline for future use. Jetting corrections for a different C.R.A.D. can be obtained with the following ratio:

$$\text{New main jet} = \frac{\text{New C.R.A.D.} \times \text{Base line M.J.}}{\text{Base line C.R.A.D.}}$$

Example: Testing results in a 570 M.J. at a C.R.A.D. of 105.4%. Two weeks later at the race track, the C.R.A.D. is 110.9%.

$$\text{The new M.J.} = \frac{110.9 \times 570}{105.4}$$

New M.J. = 600

Useful Equations

$$\text{C.F.} = \frac{29.92}{B - E} \times \frac{460 + T}{520}$$

C.A.P. = B - E

$$\text{C.R.A.D.} = \frac{1737.97 \times \text{C.A.P.}}{460 + T}$$

Where:

B = barometer reading (in-Hg)

E = vapor pressure (in - Hg) = $\text{S.P.} \times \frac{\text{R.H.}}{100}$
or use wet bulb/dry
bulb temperature and
psychrometric chart

T = carb. inlet air temp (°F)

S.P. = saturation pressure (in-Hg)

R.H. = relative humidity (%)

C.A.P. corrected air pressure (in-Hg)

C.HP = Corrected brake horsepower

B.S.F.C. = Brake specific fuel consumption

C.R.A.D. = Corrected relative air density (%)

E.G.T. = Exhaust gas temperature

W.O.T. = Wide open throttle

SECTION 04 - ENGINE PREPARATION

| SATURATION PRESSURE (CHART 1) | |
|-------------------------------|------------------------------------|
| T = TEMP. (°F) | S.P. = SATURATION PRESSURE (in-Hg) |
| - 40 | .004 |
| - 30 | .008 |
| - 20 | .012 |
| - 10 | .020 |
| 0 | .040 |
| 5 | .055 |
| 10 | .070 |
| 15 | .090 |
| 20 | .110 |
| 25 | .140 |
| 30 | .170 |
| 35 | .208 |
| 40 | .247 |
| 45 | .314 |
| 50 | .380 |
| 55 | .450 |
| 60 | .521 |
| 65 | .630 |
| 70 | .739 |
| 75 | .884 |
| 80 | 1.030 |
| 85 | 1.225 |
| 90 | 1.420 |
| 95 | 1.675 |
| 100 | 1.930 |

Most racers use an air density gauge. This gauge is fairly inexpensive. It basically establishes C.R.A.D. for you by combining the variables on any given day.

First, establish a base line main jet by testing.

After you have determined the correct main jet, record the jet number and the air density gauge reading.

Example: Base line

Gauge reading 90

Main jet 300

The next day at the track, your air density gauge now reads 105. This means you have gained 15% air density.

New density 105

Base line 90

$105 - 90 = 15$

Multiply your base line main jet by 115.

Example: $300 \times 115 = 345$

Round off to next highest jet size.

New main jet = 350

Air density can change rapidly during the course of the day. Check your gauge frequently. Always use the same gauge for a different gauge may read differently.

SECTION 04 - ENGINE PREPARATION

Exhaust Gas Temperature Probe Location

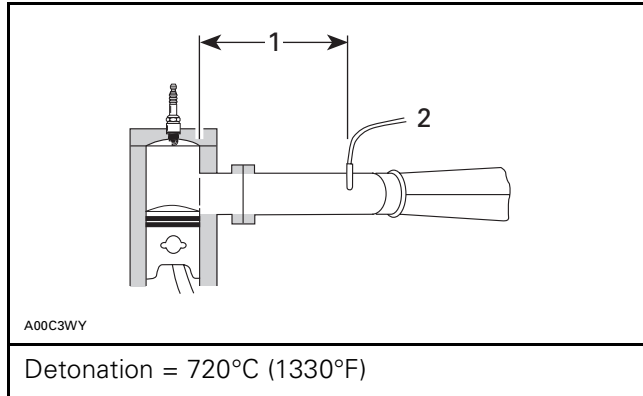

1. 100 mm from piston
2. Probe

NOTE: Temperature at wide open throttle at maximum HP RPM.

Exhaust gas temperatures (E.G.T.'s) can also give an indication of mixture ratio. At wide open throttle (W.O.T.) at maximum HP RPM, a leaner mixture will produce higher E.G.T.'s and a richer mixture will result in lower E.G.T.'s. (E.G.T.'s are not absolute. Engines have seized with E.G.T.'s in the allowable range).

Carburetor Operation

The operation of the carburetor is based on the physical principle that fluids (air is a fluid) under pressure gain speed but lose pressure when passing through a converging pipe (venturi).

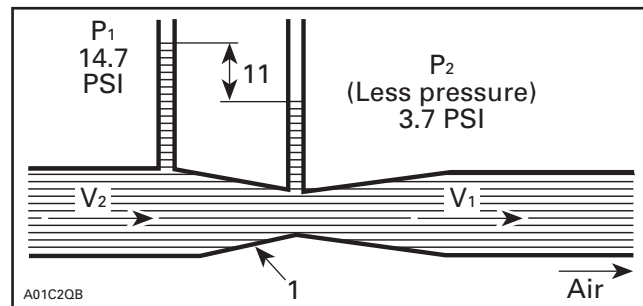

1. Venturi

Air entering the bell of the carburetor has a speed of V_1 and pressure of P_1 . As the air is forced into the smaller diameter of the venturi, speed increases (V_2) but pressure drops (P_2).

Passages in the carburetor connect the venturi to a reservoir of fuel (float bowl). The float bowl is vented to the atmosphere (P_1). P_1 is greater than P_2 so fuel is pushed from the bowl to the venturi via the jets and passages. Varying the size of jets varies the amount of fuel the engine receives. Engine speed is controlled by varying the amount of air/fuel mixture that the engine receives.

Liquid gasoline does not burn, so for the engine to run efficiently, the fuel must be broken down into small droplets, and mixed with the oxygen molecules in the incoming air. This is referred to as atomization. The shape of the venturi and the shape and location of the jets and fuel delivery passages will determine how well the fuel and air are mixed.

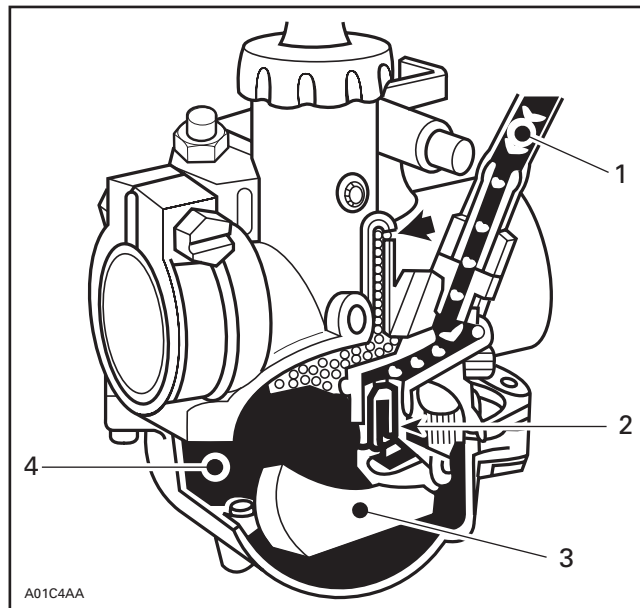

1. Float bowl
2. Needle valve
3. Float
4. Fuel inlet

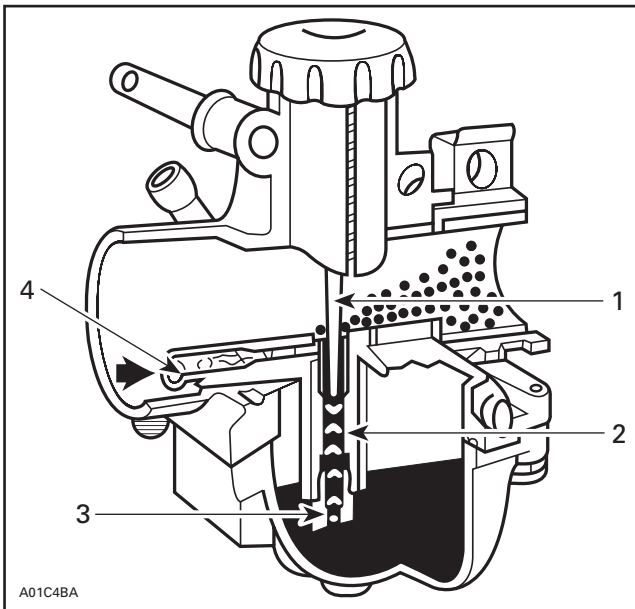

1. Jet needle
2. Needle jet
3. Main jet
4. Air jet

MIKUNI VM AND TM TYPE CARBURETORS

Snowmobile engines are operated under a wide range of conditions, from idling with the throttle valve remaining almost closed to the full load (the maximum output) with the throttle valve fully opened. In order to meet the requirements for the proper mixture ratio under these varying conditions, a low-speed fuel system (the pilot system) and a main fuel system (the main system) are provided in Mikuni VM and TM type carburetors.

While this text covers the VM-type carb., the TM flat slide carb. functions the same. The circuits function the same and tuning a TM would be done in the same manner as the VM.

TM 40 CARBURETORS

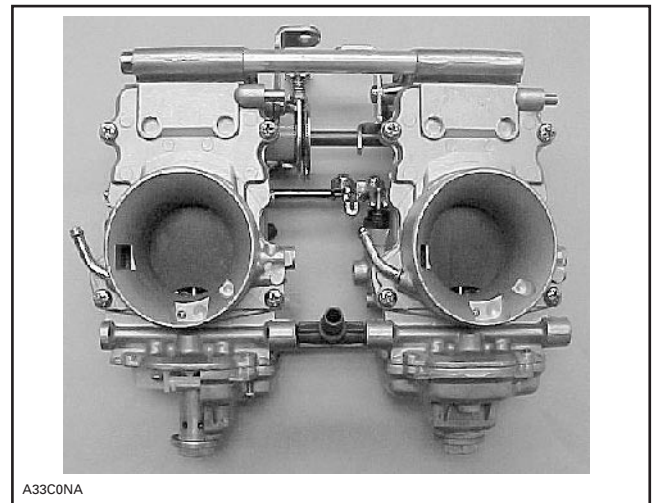

The TM 40 carburetor "rack" system is used on all liquid cooled engine models except the 2004 MX Z X 440 REV. While they are considerably different than the VM's of years ago and have a similar appearance to the TMX style of the 440 REV, the basic circuit operations remain the same. There are very few interchangeable components between the 3 styles. This section will give you a brief overview and component location of the TM 40. This is not to replace the shop manual of the model being used.

There is one common fuel inlet between both carburetors. It is sealed with O-rings to each carb body.

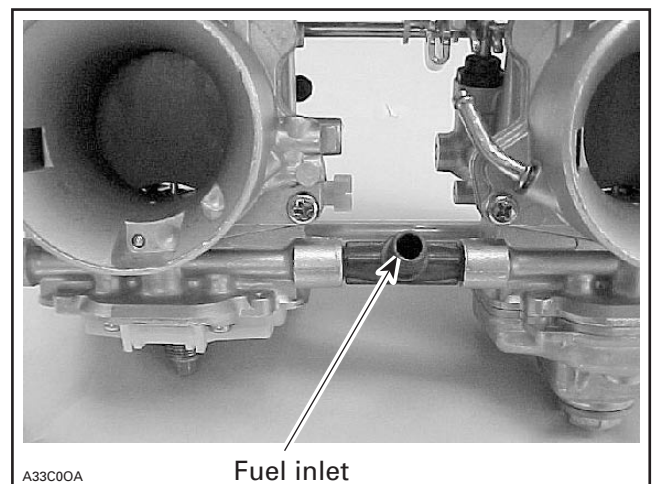

SECTION 04 - ENGINE PREPARATION

The inlet needle, seat and float are of integral construction, and must be replaced as a set. The float level is not adjustable. The floats are lightweight and placed high in the body of the carburetor to ensure consistent fuel levels even in extremely bumpy conditions.



The float bowl is sealed with an O-ring and held in place with one small Phillips screw and the Main Jet baffle.



The Main Jet is a standard Mikuni long hex.

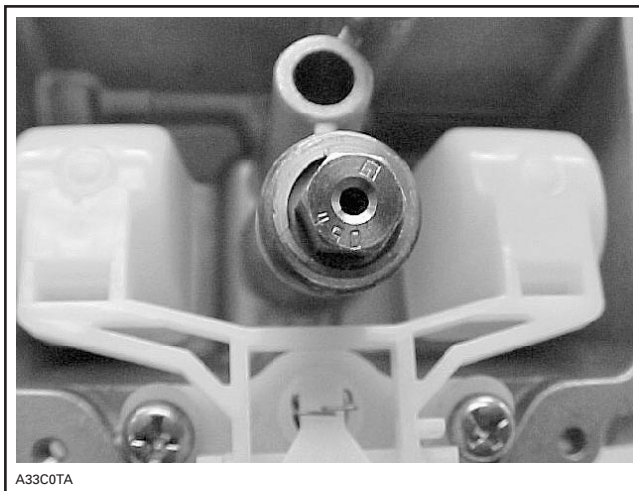

The Needle Jet is cast into the body of the carburetor and not removable.

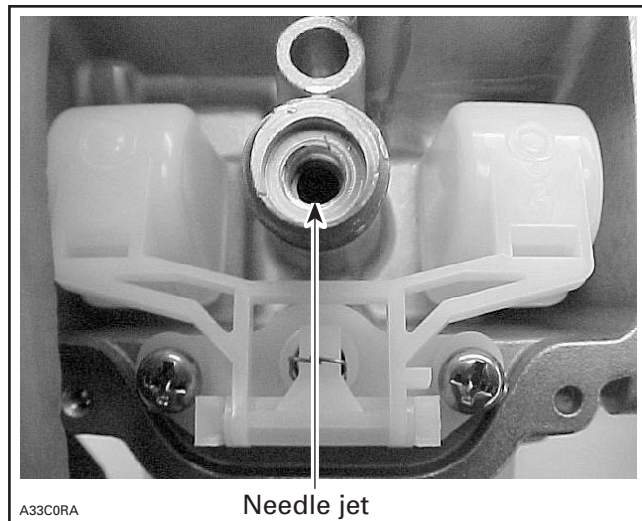
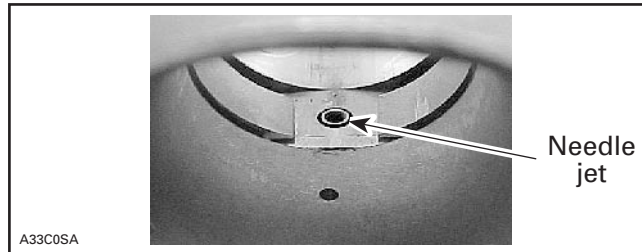

The Pilot Jet is similar to a VM, however it is extremely small. As an example the MXZ 800 uses a 17.5 Pilot Jet.



SECTION 04 - ENGINE PREPARATION

There is no pilot air-screw used, as on VM carburetor. Instead there is a low speed fuel screw on the engine side of the throttle slide. This screw controls fuel, so the more turns out, the richer the mixture becomes. **Do not forget this.**

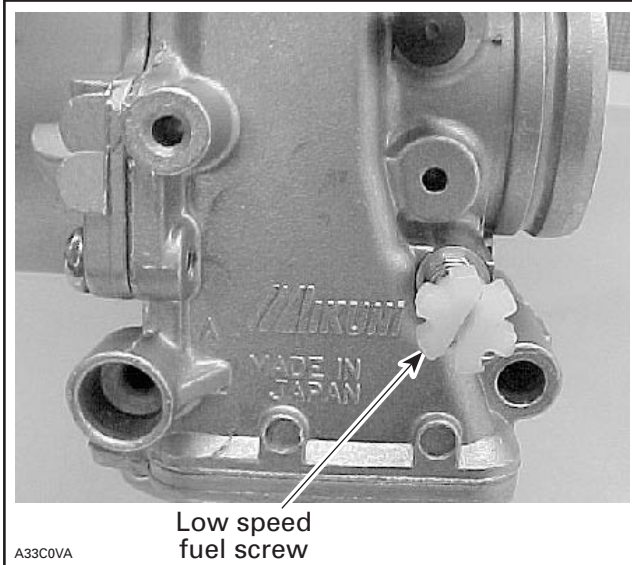

While the carburetor bore is round, the throttle slide has a flat guillotine shape. We can achieve faster throttle response from this type of carburetor design, especially in the midrange. Also, the air flow at WOT, or wide open throttle is slightly better than a similar sized VM. The slides are numbered for the cut-away as VM slides.

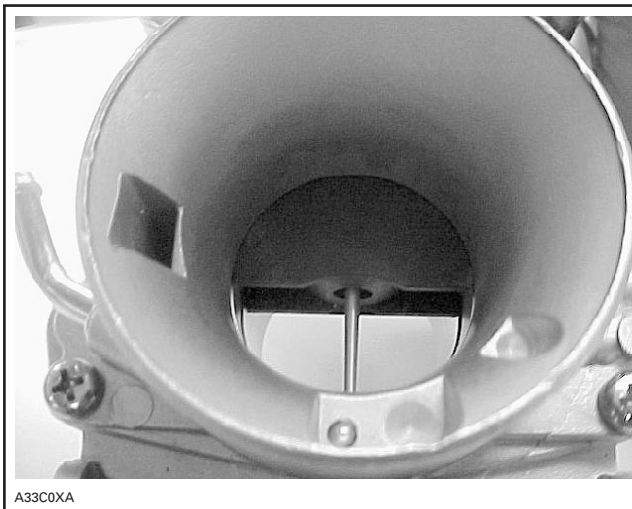

The Jet Needle is specifically made for TM style carburetor and are calibrated for each specific engine size. The e clip is not adjustable as only one groove is provided! **High altitude calibrations will normally require a different Jet Needle.**



A single idle speed screw is used to adjust both carburetors. The carbs are synchronized at the factory and nothing other than idle speed adjustment needs to be done unless the carburetors are disassembled. Refer to the appropriate shop manual for the correct procedure.

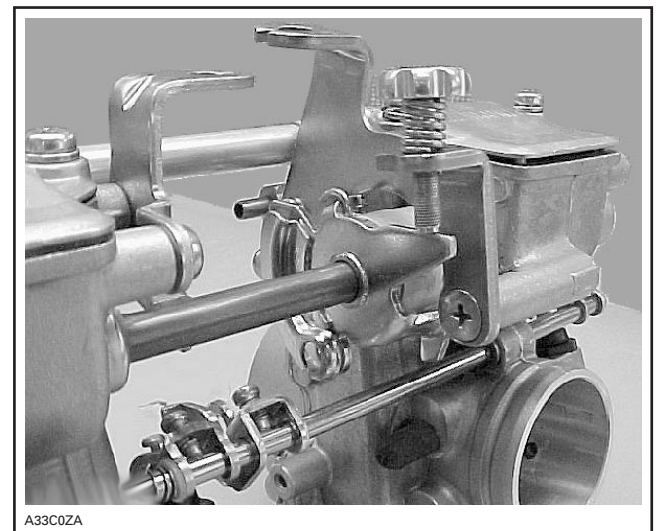

SECTION 04 - ENGINE PREPARATION

The float bowls are now vented to the air box. This gives us a much more precise calibration, especially at higher speeds since the pressure in the float bowl remains the same as the pressure in the carburetors' inlet.

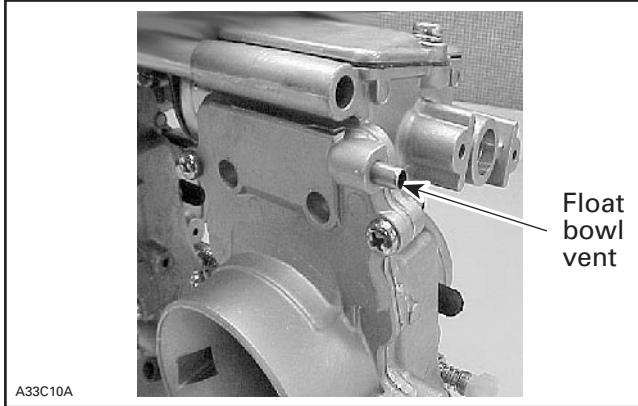

The TM carburetors have the ability to use the heated coolant from the engine to prevent ice buildup. Engine coolant is directed from the cylinder head through a user operable shut-off valve under the hood. It then passes through the PTO carb body, through a connecting hose to the MAG carb to warm the throttle slides. The coolant circulates back to the coolant bottle. This valve should normally be opened any time the temperature is around approximately 38°F (5°C).

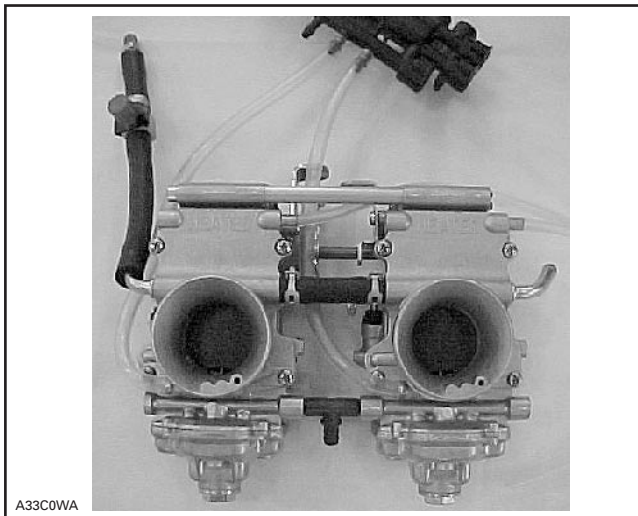

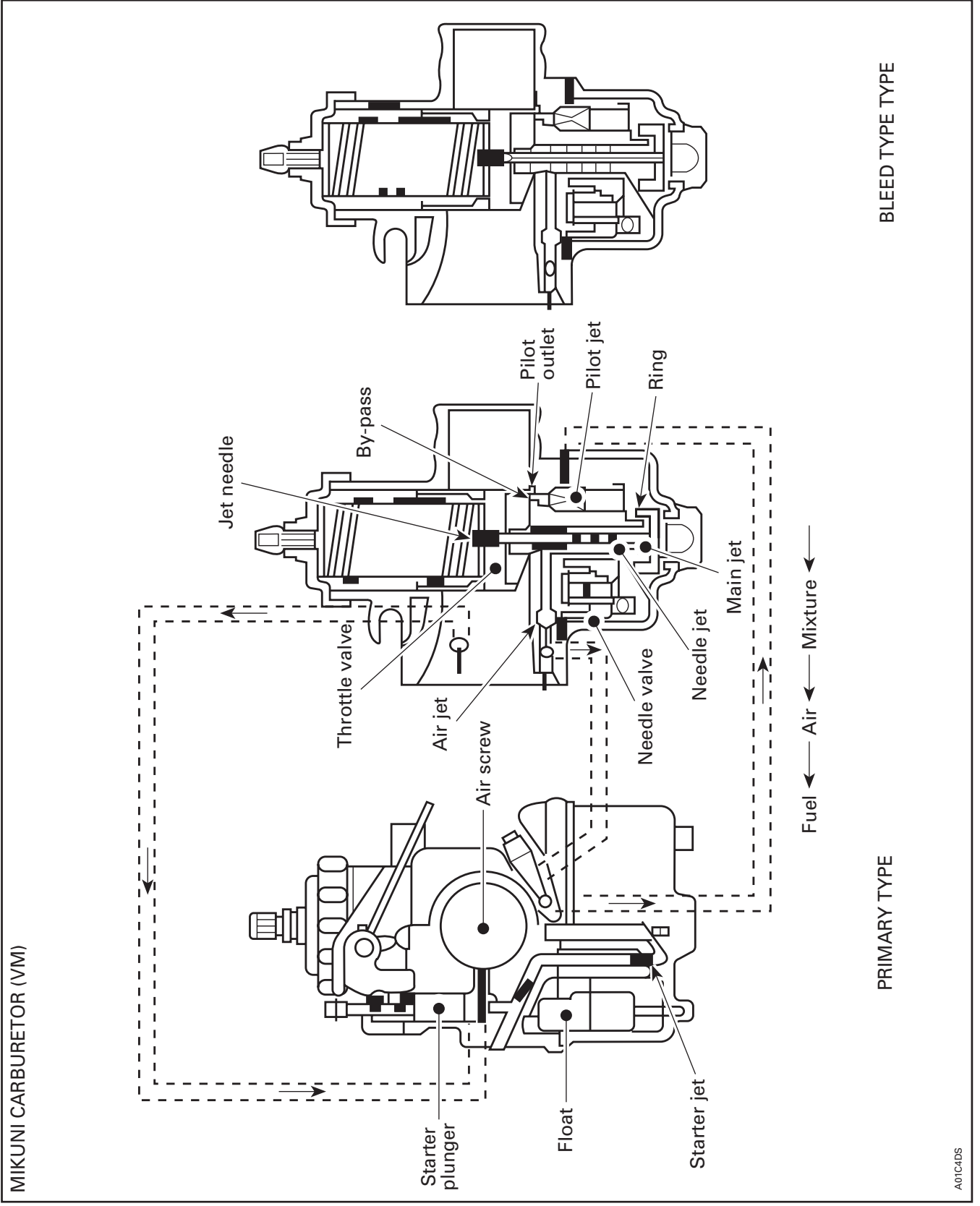

SECTION 04 - ENGINE PREPARATION

Starting Device (enrichner)

Instead of a choke, the enrichner system is used on some Mikuni carburetors. In the starter type, fuel and air for starting the engine are metered with entirely independent jets. The fuel metered in the starter jet is mixed with air and is broken into tiny particles inside the emulsion tube. The mixture then flows into the plunger area, mixes again with air coming from the air intake port for starting and is delivered to the engine in the optimum air/fuel ratio through the fuel discharge nozzle. The starter is opened and closed by means of the starter plunger. Since the starter type is constructed so as to utilize the negative pressure of the inlet pipe, it is important that the throttle valve be closed when starting the engine.

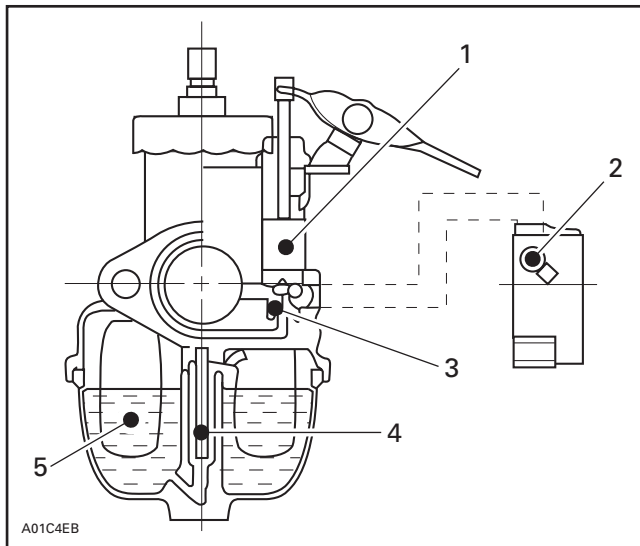

1. Plunger area
2. Emulsion tube
3. Inlet pipe
4. Needle jet
5. Float

Selection of the Aperture of Carburetor

One of the prerequisites for improving the output is to use a carburetor with as large an aperture as possible. However, a large aperture alone does not necessarily improve the output. As shown in the following illustration, it is true that a large aperture improves the power output in the high speed range. In the slow speed range, on the other hand, the output drops. The aperture of a carburetor is determined by various factors. These factors include (1) whether the vehicle is intended for racing, (2) the design of the engine, (3) driving technique of the driver, (4) the driver's preference, etc. In addition, the maximum output, the maximum torque and the minimum number of revolutions for stable engine operation must also be taken into account.

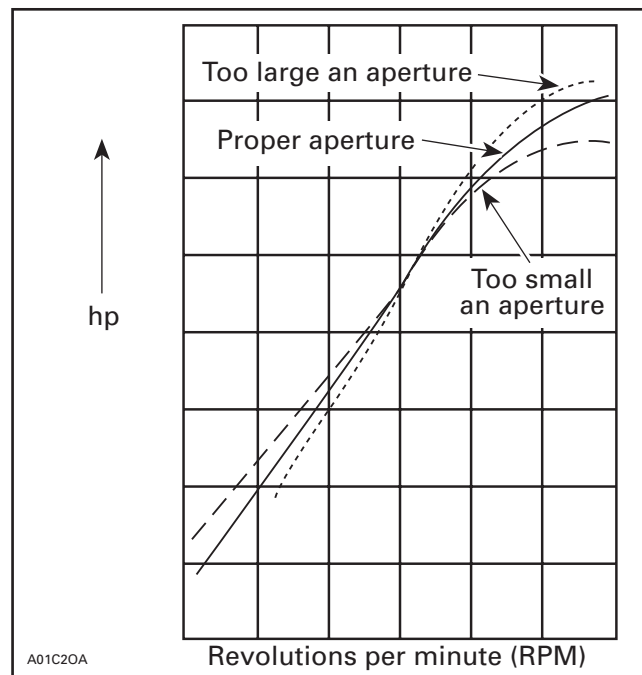

Size of Mikuni Carburetors

Mikuni VM-type carburetors come in various sizes, with the main bore ranging from 10 mm (.39 in) to 44 mm (1.73 in) (in even numbers for the most part.) The carburetor body is made of aluminum or zinc.

Carburetor Test

Once the aperture of the carburetor is determined, a test to select the proper jet should be made. The size of the jet is determined by measuring the output in a bench or in a chassis dynamo test. For racing, it is best to determine the proper size of the jet on the racing track, because the following points must be taken into account:

- a. The altitude (atmospheric pressure), temperature and humidity of the race track.
- b. The operation of the engine based on the topography of the race track.

Pilot/Air System

PRINCIPLES OF OPERATION

The pilot/air system controls the fuel mixture between idle and approximately the 1/4 throttle position. As the throttle is opened wider for low speed operation, the pilot outlet cannot supply adequate fuel, and fuel then enters the carburetor bore from the bypass as well as the pilot outlet. The pilot/air system is tuned by first adjusting the air screw; then, if necessary, by replacing the pilot jet.

Adjusting Air Screw

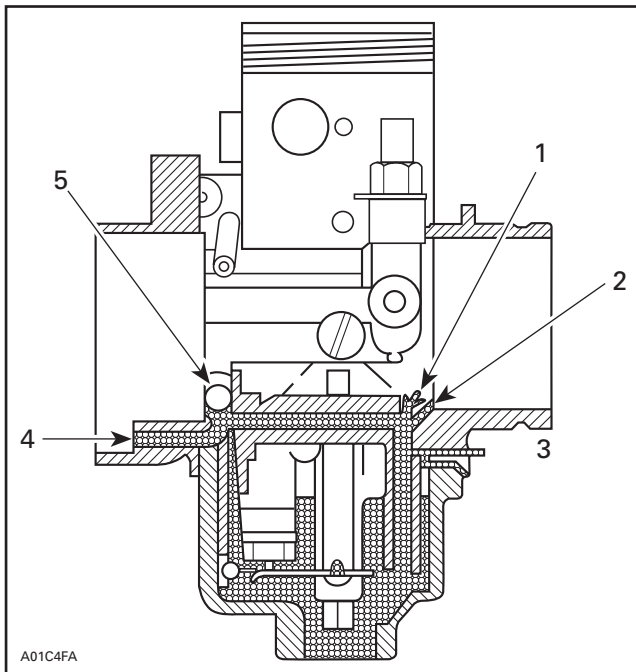

1. Pilot bypass
2. Pilot outlet
3. Pilot jet
4. Air intake
5. Air screw

NOTE: This procedure may be performed for single and dual carburetors. Never adjust screws more than 1/4 turn at a time.

1. Turn idle stop screw in until screw contacts throttle valve. Then turn idle stop screw in 2 additional turns.
2. Start and warm up engine. Adjust idle stop screw to 500 RPM above normal idle speed. See **Low-Speed Fuel System**.
3. Turn air screw in or out using 1/4-turn increments until engine RPM peaks or reaches its maximum RPM.
4. Readjust idle stop screw to return engine to normal idle speed. See pages **Low-Speed Fuel System**.
5. Repeat Steps 3 and 4 until engine operates at normal idle speed and air screw is peaked.
6. When air screw is adjusted stop engine. Note the setting of air screw and turn it all the way in. If it takes less than 1 turn, the pilot jet is too small and a larger one must be installed. If it takes more than 2-1/2 turns to set air screw, the pilot jet is too large and must be replaced by a smaller one.
7. Turn the air screw left and right (between 1/4 and 1/2 turn) and select the position where the engine revolution reaches the maximum. Adjust the throttle stop screw to bring down the engine revolution to your target speed for idling. After this adjustment of the throttle stop screw is made, select once more the position where the engine revolution reaches the maximum, by turning the air screw left and right (between 1/4 and 1/2 alternately). At this point, attention should be paid to the following points.
 - a. If there is a certain range in the opening of the air screw where the fast engine revolution can be obtained (for instance, the number of revolutions does not change in the range of 1-1/2 to 2.0 turns), it would be better for acceleration to 1-1/2 turns.

SECTION 04 - ENGINE PREPARATION

- b. To determine the **fully closed** position of the air screw, turn the air screw slightly. Excessive tightening of the air screw would damage the seat. The position where the air screw comes to a stop should be considered the **fully closed** position. The maximum number of turns in the opening of the air screw must be limited to 3.0. If the air screw is opened over 3.0 turns, the spring will not work and the air screw can come off during operation of the vehicle.

Replacing Pilot Jet

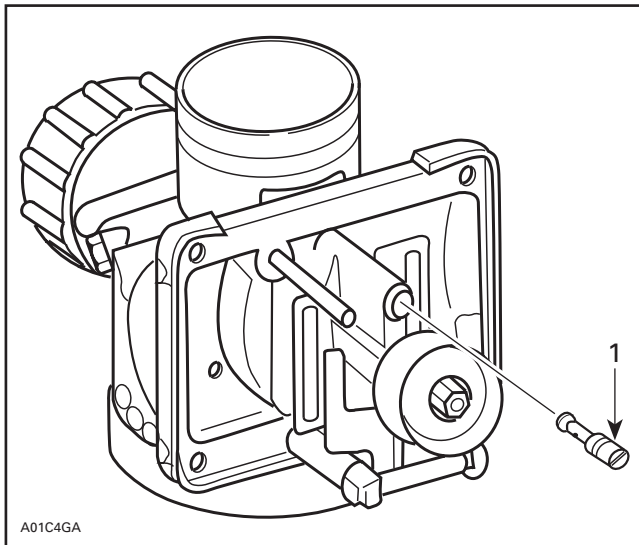

1. Pilot jet

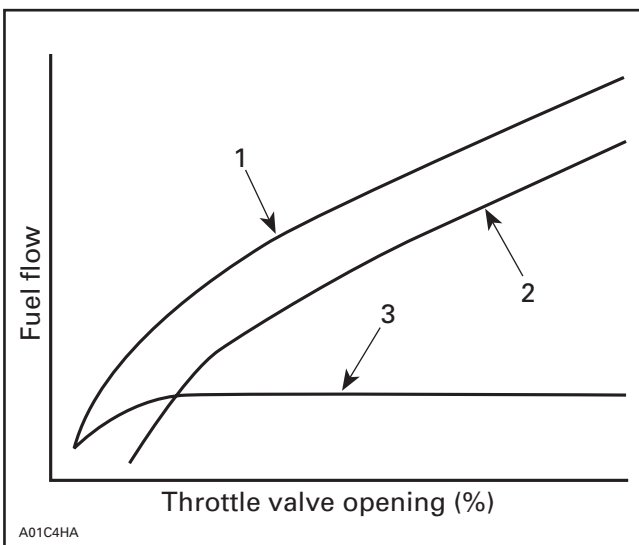

1. Total amount of fuel flow
2. Main fuel system
3. Pilot fuel system

Pilot jets are numbered from no. 15 (the smallest) to no. 80 (the largest). The number corresponds to fuel flow and not necessarily to drill size or through-hole diameter. After changing the pilot jet, check and adjust air screw as described above.

NOTE: Since the pilot/air system provides some fuel up to wide open throttle, changes in this system will affect the throttle valve, jet needle/needle jet, and main jet metering systems.

Throttle Valve

PRINCIPLES OF OPERATION

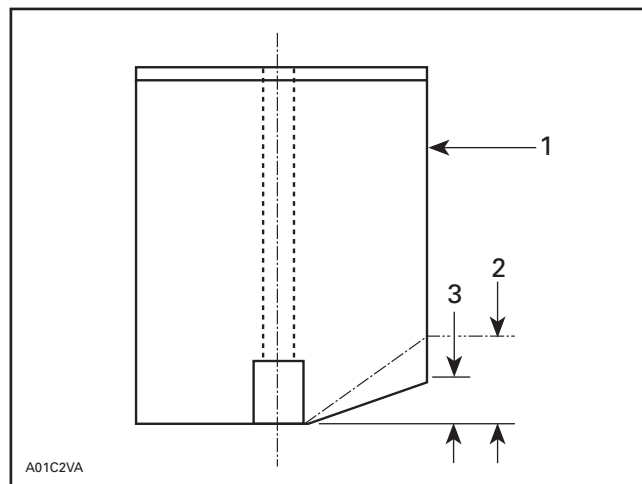

1. Throttle valve
2. 3.0
3. 2.0

The throttle valve is cut away on the air inlet side to help control the fuel/air mixture at low and intermediate throttle settings. The size of cut-away also affects acceleration.

Throttle valves are numbered from 0.5 to 4.5 in 0.5 increments based on the size of the cut-away. The most commonly used configurations are 1.5 to 3.5. The higher the number, the greater the cut-away and the larger the air flow.

The throttle valve functions in about the same range as the pilot/air system. After the air screw is adjusted, it can be used to check the throttle valve selection.

NOTE: Too lean of a slide cut-away can cause piston seizures during sudden throttle closures from large throttle settings.

CHECKING AND SELECTING THROTTLE VALVE

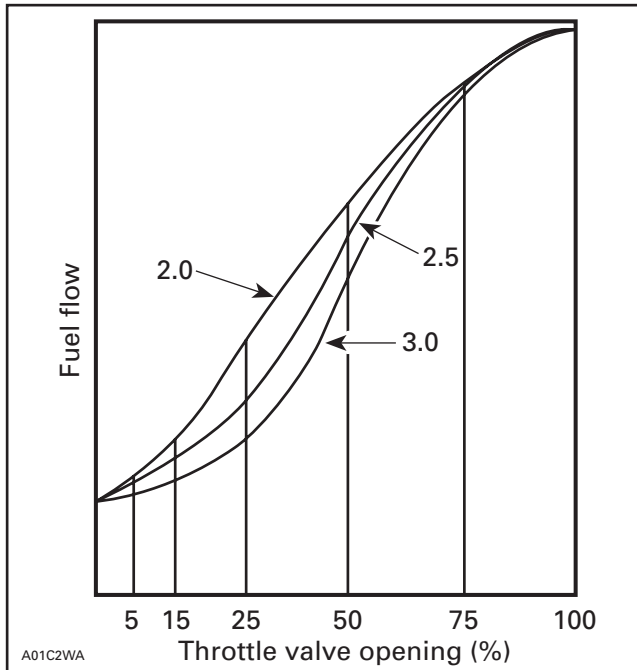

1. Operate engine at low throttle settings, accelerating from idle to 1/4 throttle.
2. If engine bogs during acceleration, there is probably insufficient fuel. Turn in air screw about 1/4 turn at a time. If engine acceleration is improved, after adjusting air screw, the throttle valve cut-away needs to be decreased.
3. If engine runs rough or smokes excessively during acceleration, there is probably too much fuel. Turn out air screw 1/4 turn at a time. If engine operation is improved, the throttle valve cut-away needs to be increased.

NOTE: Illustration above indicates fuel flow according to throttle valve size and the amount throttle valve is opened.

4. Increase or decrease throttle valve cut-away size in 0.5 steps.
5. Return air screw to its original setting and operate engine at low throttle settings. Accelerate engine from idle to 1/4 throttle; engine should accelerate smoothly.
6. As a final check, change the position of the air screw. If this does not significantly affect engine performance (as in steps 2 and 3), the throttle valve is correct.

Jet Needle

PRINCIPLES OF OPERATION

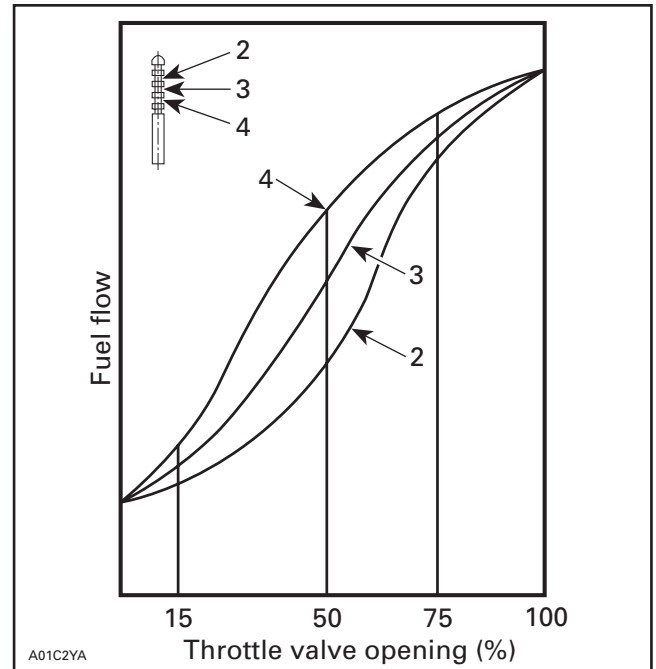

The jet needle works with the needle jet to increase the amount of fuel as the throttle valve is raised.

Although the jet needle and needle jet function in the 1/4 to 3/4 throttle range, they also affect the amount of fuel present at wide open throttle. When tuning the jet needle, also check main jet system operation.

SECTION 04 - ENGINE PREPARATION

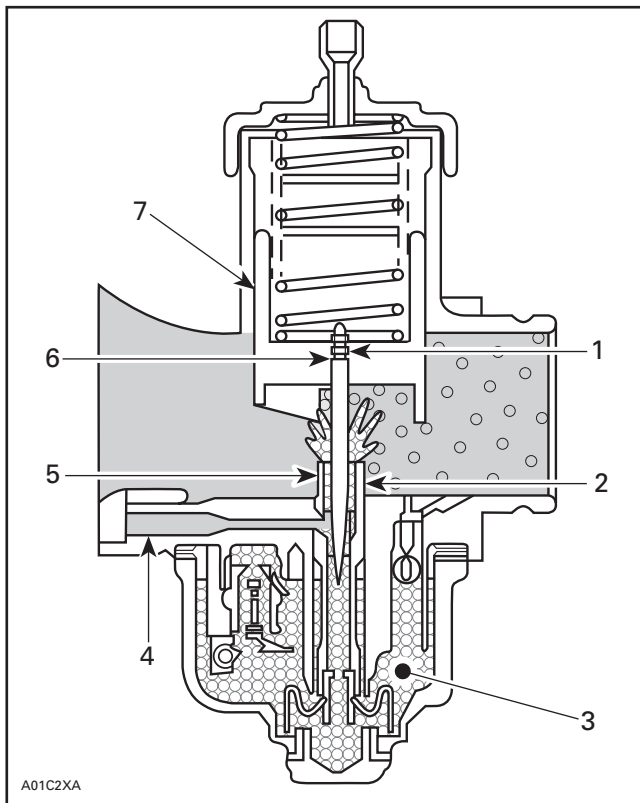

1. E-ring
2. Needle jet
3. Fuel
4. Air
5. Metered here
6. Jet needle
7. Throttle valve

The jet needle raises and lowers with the throttle valve which changes jet needle position in the needle jet. Because the jet needle is tapered from top to bottom, an increasing amount of fuel is delivered through the needle jet whenever the throttle valve is raised. Increased or decreased air flow, by the throttle valve position, regulates the amount of fuel through the needle jet and around the jet needle.

The jet needle works on combination of length, taper, and E-ring position. Each jet needle has a number and letter series stamped on the body.

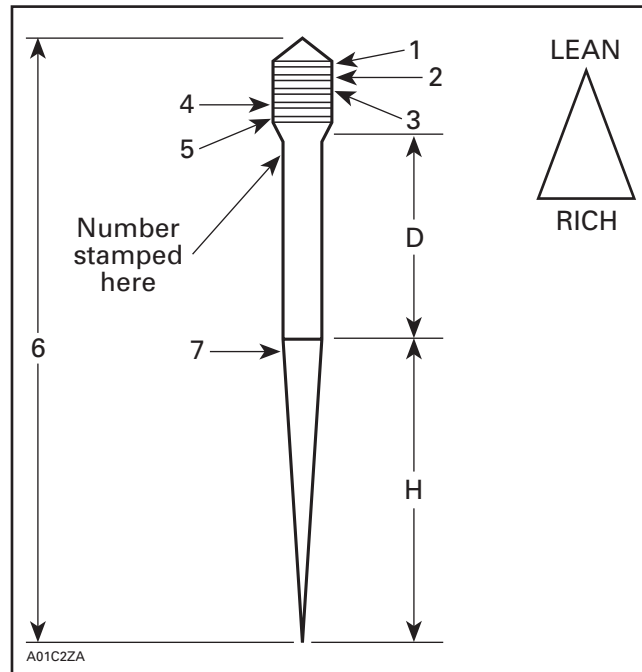

Example: 6DH7

6 - Basic length of needle.

DH - A single letter would indicate a single taper of the needle, double letter a double taper, and three letters mean there is a triple taper.

D - Amount of taper at top of needle.

H - Amount of taper at bottom of needle.

7 - Material, type of coating and start of second taper on needle.

NOTE: Letter designation of the jet needle indicates the angle of taper. Each letter (starting with A is 0.25° greater than preceding letter. Example: D = 1° , E = $1-1/4^\circ$, F = $1-1/2^\circ$, G = $1-3/4^\circ$, and H = 2° . This applies to both single and double taper needles.

At the top of the jet needle are five grooves numbered 1 through 5 from top to bottom. The number 3 or middle groove being the starting point for the E-ring. The E-ring position on any jet needle determines the rich or lean part throttle or mid-range carburetor operation.

Moving E-ring to position 1 or 2 lowers jet needle into needle jet and leans out the fuel/air mixture. Similarly, moving E-ring to position 4 or 5 raises jet needle in needle jet and enriches the fuel/air mixture.

POSITIONING THE E-RING

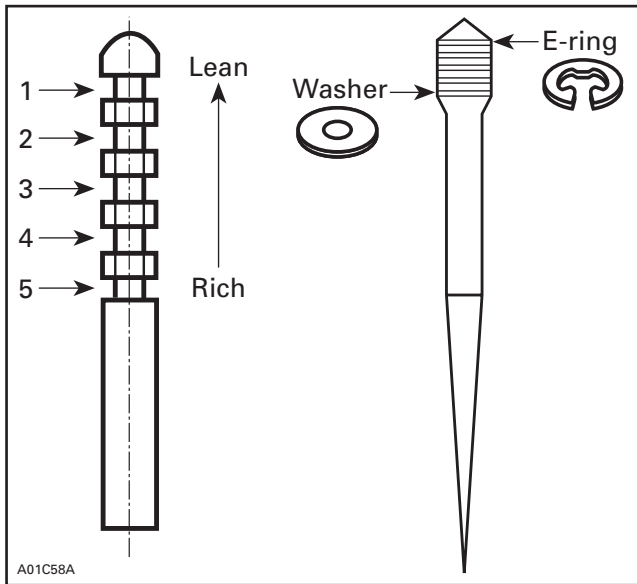

1 to 5 = E-ring position

1. Check for a rich or lean setting by examining exhaust manifold. A very light brown or white color indicates a lean mixture. A very dark brown or black color indicates a rich mixture. The proper color is tan.
2. Move E-ring one groove at a time to correct the fuel/air mixture.
3. If proper operation is obtained at all but the 3/4 throttle setting after the main jet has been tuned, operation may be improved by changing the jet needle taper. Do not, however, change the jet needle until main jet and E-ring position have been thoroughly checked.
4. If the E-ring is in the number 5 position and operation is still lean, a needle jet with a larger orifice may be installed. This may be done only after thoroughly checking the main jet, jet needle, and E-ring positions.

NOTE: Make sure washer is installed under E-ring on vehicles so equipped.

Needle Jet

PRINCIPLES OF OPERATION

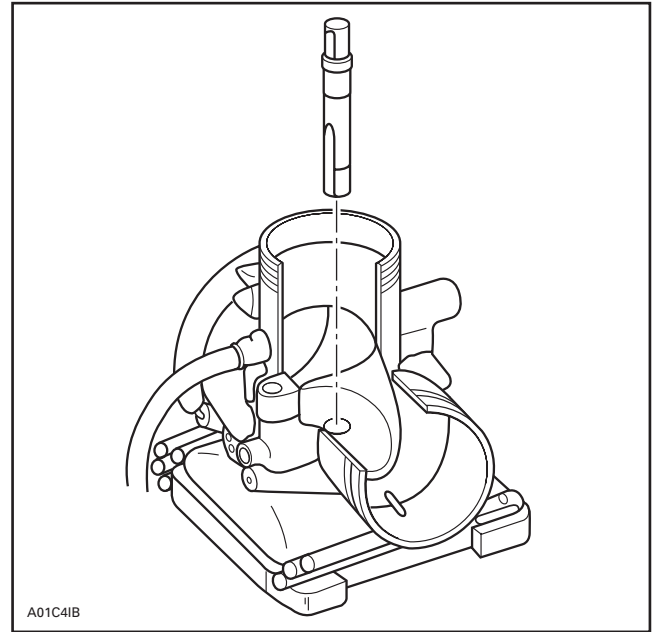

The needle jet works in combination with the jet needle to meter the fuel flow in the mid range.

Changes to the needle jet should be made only if the results of changing the jet needle position are unsatisfactory. In stock applications, except for specific calibration changes necessary at high altitudes, the needle jet should not be changed. Selection of the proper needle jet requires much care and experience. Decreasing the needle jet size can prevent the main jet from metering the proper amount of fuel at wide open throttle.

SECTION 04 - ENGINE PREPARATION

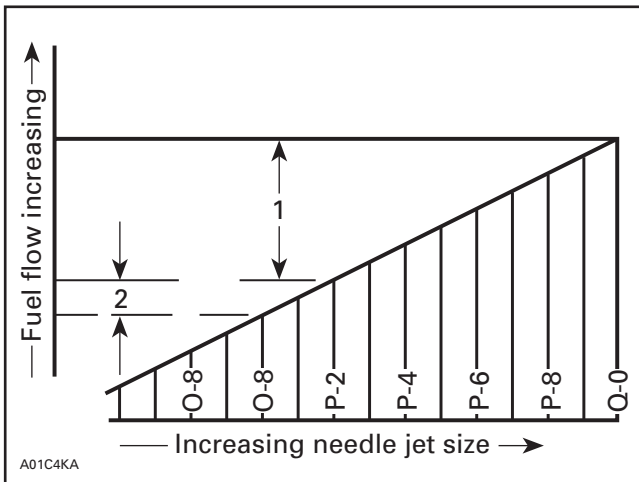
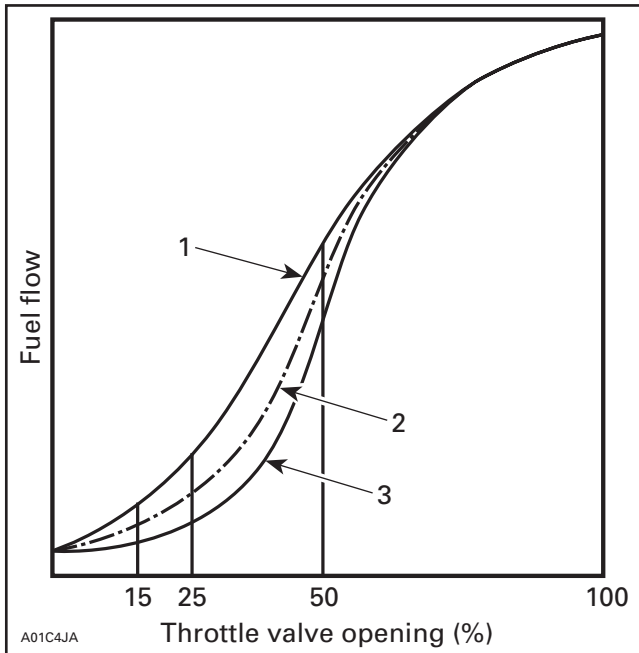

Needle jets are stamped with an alphanumeric code. The letter indicates a major change in fuel flow. P-2, for example, indicates low flow; P-4, greater flow, and so on. The number indicates minor adjustments in fuel flow. The first diagram shows the relationship between the alphanumeric needle jet size number and fuel flow.

NOTE: Needle jets carrying the numbers 166, 159 or 169 in addition to the P-2 or P-4 and are not interchangeable. Be sure correct needles are used as specified for your snowmobile.

Main Jet System

PRINCIPLES OF OPERATION

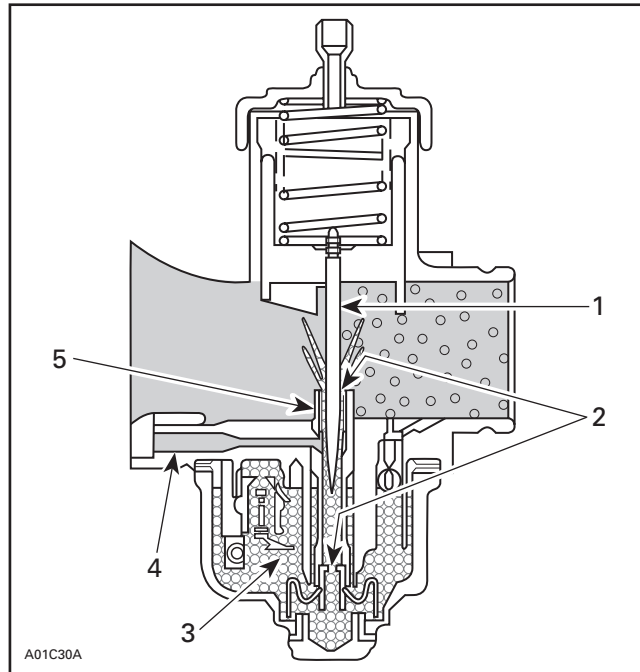

1. Jet needle
2. Metered here
3. Fuel
4. Air
5. Needle jet

The main jet system starts to function when the throttle is approximately 1/4 open. The mid range fuel is supplied by the main jet and regulated by the needle jet/jet needle combination. The main jet meters the fuel when the throttle is in the wide open position.

The main jets are available in sizes from number 50 to number 840. The size number corresponds to flow and not necessarily to hole size.

When experiencing erratic operation or overheating, check the main jet for dirt which can plug the orifice.

TUNING THE MAIN JET SYSTEM

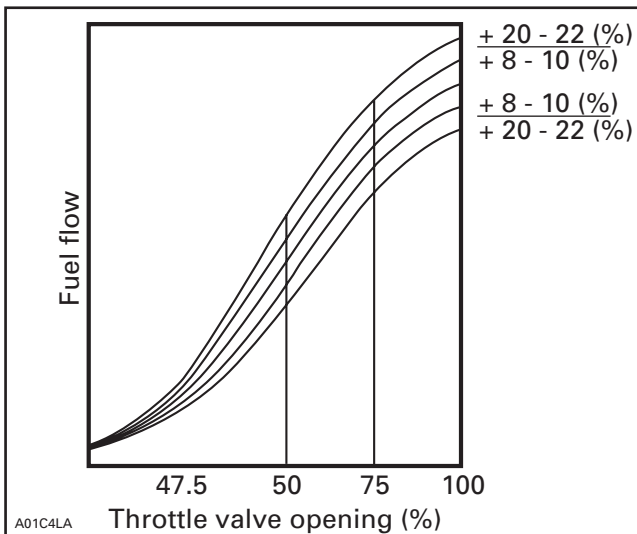

Before operating the snowmobile, make sure all parts, including clutch and drive belt, are in good operating condition.

1. Operate snowmobile at wide open throttle for several minutes on a flat, well packed surface. Change main jet if snowmobile fails to achieve maximum RPM or labors at high RPM.
2. Continue to operate at wide open throttle and shut off ignition before releasing throttle. Examine exhaust manifold and spark plugs to determine if fuel/air mixture is too lean.

NOTE: Do not change jet sizes by more than one increment (step) at a time.

3. If the exhaust manifold or spark plug insulator is dark brown or black, the fuel/air mixture is too rich. Decrease jet size.
4. If the exhaust manifold or spark plug insulator is very light in color, the fuel/air mixture is too lean. Increase jet size.
5. If you cannot determine the color, proceed as if fuel/air mixture were too lean and increase jet size. If operation improves, continue to increase jet size to obtain peak performance. If operation becomes worse, decrease jet size to obtain peak performance.
6. After proper main jet is selected, recheck jet needle and needle jet.

Troubleshooting

When the carburetor setting is not correct for the engine, various irregularities are noticed. These can be traced to two causes as a whole:

1. When the air/fuel mixture is too rich:
 - a. The engine noise is full and intermittent (four stroking).
 - b. The condition grows worse when the enricher is opened.
 - c. The condition grows worse when the engine gets hot.
 - d. Removal of the air cleaner will somewhat improve the condition.
 - e. Exhaust gases are heavy.
 - f. Spark plug is fouled.
2. When the air/fuel mixture is too lean:
 - a. The engine overheats.
 - b. The condition improves when the enricher is opened.
 - c. Acceleration is poor.
 - d. Spark plug electrodes are melted.
 - e. The revolution of the engine fluctuates and a lack of power is noticed.
 - f. Piston seizure or scuffing occurs.

SECTION 04 - ENGINE PREPARATION

Functional Range Effectiveness in Relation to Throttle Opening

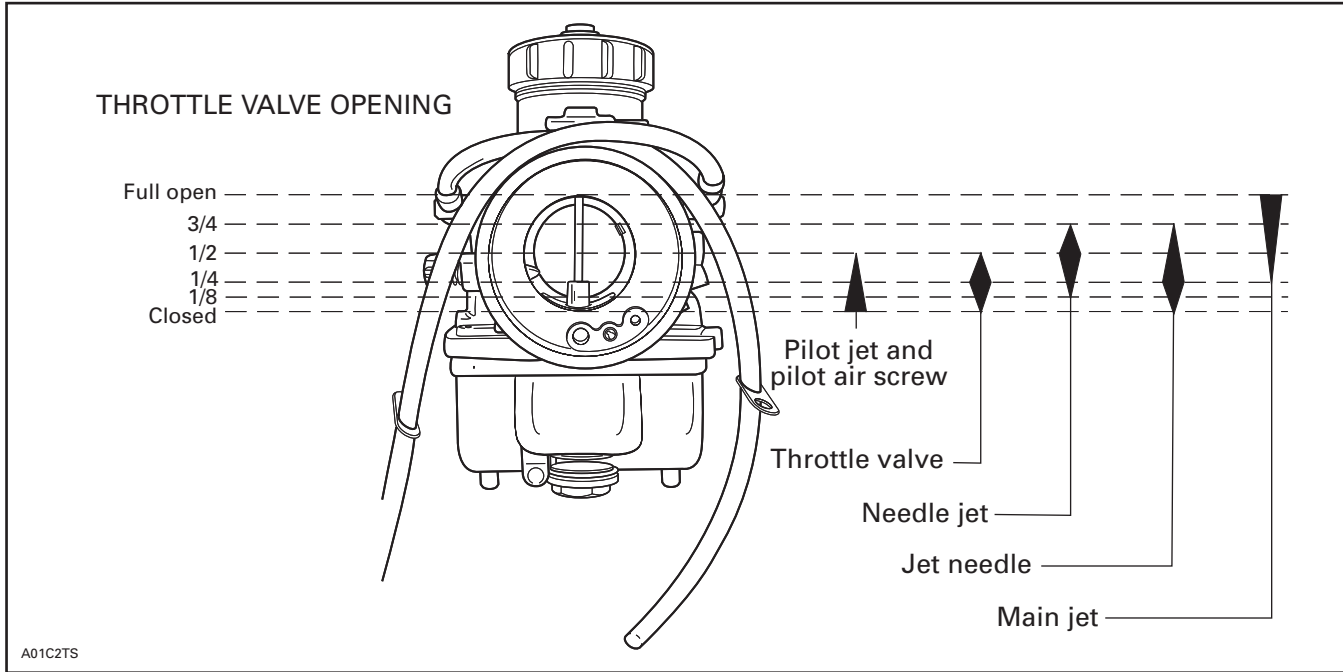

SECTION 04 - ENGINE PREPARATION

MIKUNI CARBURETOR (TMX)

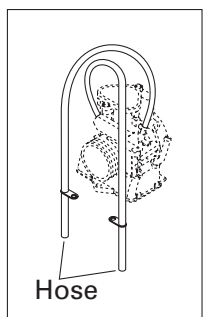
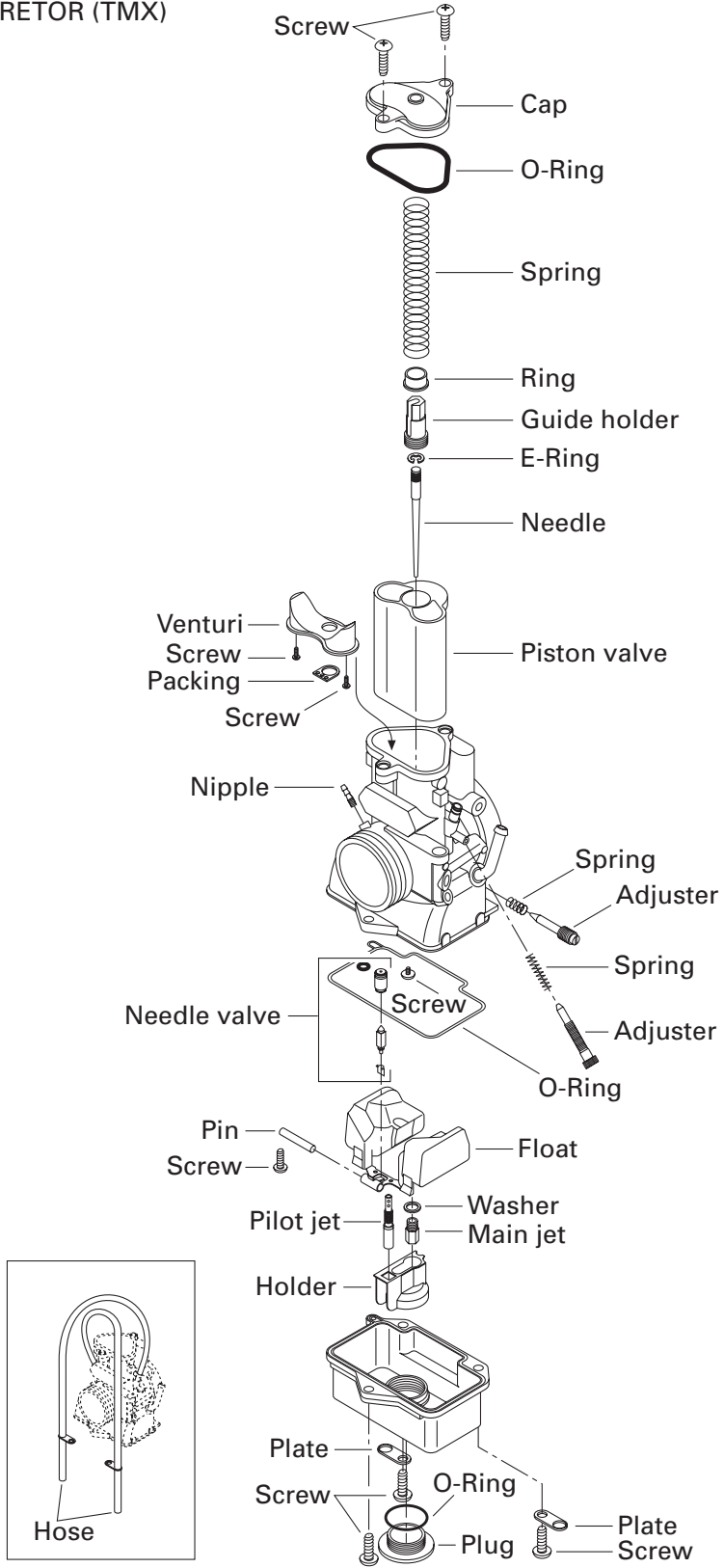

A32C34T

SECTION 04 - ENGINE PREPARATION

Mikuni TMX Carburetor (tuning parts)

| P/N | DESCRIPTION |
|-------------|-------------------------|
| 486 212 400 | Pilot Jet, 15 |
| 486 212 500 | Pilot Jet, 17.5 |
| 486 212 600 | Pilot Jet, 20 |
| 486 212 700 | Pilot Jet, 22.5 |
| 404 161 870 | Pilot Jet, 25 |
| 486 212 800 | Pilot Jet, 27.5 |
| 404 162 042 | Pilot Jet, 30 |
| 707 200 100 | Pilot Jet, 32.5 |
| 707 200 168 | Pilot Jet, 35 |
| 707 200 136 | Pilot Jet, 40 |
| 486 230 100 | Pilot Jet, 45 |
| 486 230 200 | Pilot Jet, 50 |
| 486 230 300 | Pilot Jet, 55 |
| 486 230 400 | Pilot Jet, 60 |
| 486 230 500 | Pilot Jet, 65 |
| 486 213 200 | Piston Valve, 3.0 |
| 486 213 300 | Piston Valve, 3.5 |
| 404 161 867 | Piston Valve, 4.0 |
| 486 213 400 | Piston Valve, 4.5 |
| 486 213 500 | Piston Valve, 5.0 |
| 404 161 868 | Inlet Needle & Seat 1.5 |
| 404 161 871 | Needle, J8-6FIY05-58 |
| 404 161 872 | Needle, J8-6FIY04-59 |
| 404 161 873 | Needle, J8-6FIY06-57 |

Part numbers with a 486 prefix must be ordered from Valcourt Race Dept. All others must be ordered from your local Ski-Doo dealer.

IGNITION SYSTEMS, SPARK PLUGS

Two-stroke engines in snowmobiles rely on an electric spark to initiate combustion of the fuel/air charge which has been inducted into the cylinder. For the engine to operate efficiently, the spark must be delivered at precisely the right moment in relation to the position of the piston in the cylinder and the rotational speed of the crankshaft.

Additionally, the spark must be of sufficient intensity to fire the fuel mixture, even at high compression pressure and high RPM.

It is the function of the ignition system to generate this voltage and provide it to the spark plug at the correct time.

The Nippondenso capacitor discharge ignition (CDI) system has magnets located on the crankshaft flywheel. AC voltage is induced in the generating coil(s) as the poles of the magnets rotate past the poles of the coils. Timing is controlled by a trigger coil or the position of the coil poles relative to the magnet poles, which are directly related to piston position. The CD (or amplifier) box contains the electronic circuitry to store and control the initial voltage and deliver it to the ignition coil (and then the spark plug) at the correct moment. The ignition coil is a transformer that steps up the relatively low voltage, 150-300 V, of the generating coil to the 20,400 – 40,000 volts necessary to jump the spark plug gap and initiate the burning of the fuel/air mixture in the combustion chamber.

Maximum power from a given engine configuration is produced when peak combustion chamber pressure (about 750 PSI) takes place at about 15° of crankshaft rotation ATDC. Normal combustion is the controlled burning of the air/fuel mixture in the cylinder. The flame is initiated at the spark plug and spreads to the unburned mixture at the edges of the cylinder.

This flame front travels through the cylinder at about 100 feet per second. In order to achieve maximum pressure at about 15° ATDC, the spark must occur about 15° before TDC. Complete combustion will finish at about 35° ATDC. The actual amount of spark advance BTDC is dependent upon bore size, combustion chamber shape, operating RPM, mixture turbulence and the actual flame speed.

Flame speed is directly proportional to piston speed in an almost linear fashion. Though it is not completely understood why this relationship exists, it is thought to be related to intake speed and mixture turbulence. Hence, flame speed increases as RPM increases. It also increases as the air/fuel ratio becomes leaner.

Because the flame speed is slower at lower RPM's, more advance at low RPM is necessary for maximum performance. Advancing the spark too much BTDC for the needs of the engine will cause the engine to go into detonation.

The optimum ignition would then have timing significantly advanced at lower RPM, but would retard the timing at higher RPM to keep the engine out of detonation. Generally, as the ignition timing is advanced, the low end mid range power will be improved and the peak power will be moved to a lower RPM. Retarding the timing will generally reduce low and mid range power but may allow jetting to be leaner and increase peak power. Peak power will be moved to a higher RPM. These are generalizations and ignition timing must be optimized depending on engine design, RPM range and operating conditions.

Ignition advance on Rotax engines is measured by a linear distance of piston travel BTDC. A dimension taken through a straight spark plug hole in the center of the head is a direct measurement. A dimension through an angled plug hole on one side of the head is an indirect measurement. A direct measurement can be converted to degrees of crankshaft rotation by the appropriate formulas. Initial ignition timing procedures can be found in the *Shop Manual* for the particular model being worked on.

Ignition Timing

Ignition timing is no longer able to be adjusted mechanically. It must be done by your dealer with an MPEM programmer.

Spark Plug Heat Range

Spark plug heat ranges are selected by measuring actual combustion chamber temperatures. A colder spark plug, one that dissipates heat more rapidly, is often required when engines are modified to produce more horsepower.

The proper operating temperature or heat range of the spark plugs is determined by the spark plugs ability to dissipate the heat generated by combustion.

The longer the heat path between the electrode tip to the plug shell, the higher the spark plug operating temperature will be — and inversely, the shorter the heat path, the lower the operating temperature will be.

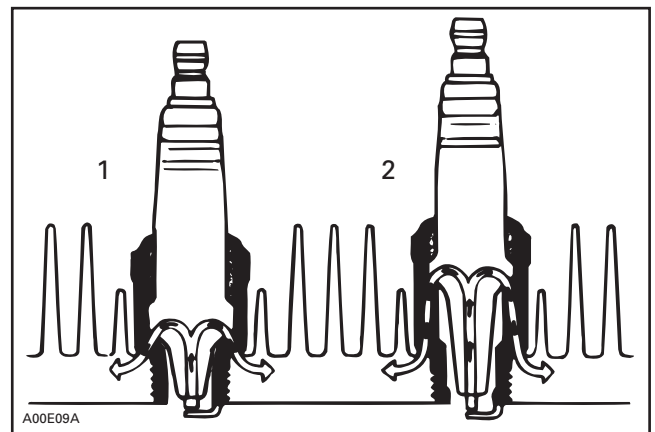

1. Cold
2. Hot

A cold type plug has a relatively short insulator nose and transfers heat very rapidly into the cylinder head.

Such a plug is used in heavy duty or continuous high speed operation to avoid overheating.

The hot type plug has a longer insulator nose and transfers heat more slowly away from its firing end. It runs hotter and burns off combustion deposits which might tend to foul the plug during prolonged idle or low speed operation.

Generally speaking, if you have increased horsepower by 10-15%, you will have to change to the next colder heat range spark plug.

Most Ski-Doo's are equipped stock with NGK BR-9ES spark plugs. These are resistor-type plugs which help reduce radio frequency interference.

To help prevent spark plug fouling use BR9ECS type plug. Used **ONLY** resistor type plugs.

SECTION 04 - ENGINE PREPARATION

Design Symbols Used on NGK Spark Plugs

| First letter prefix for thread and hexagon size | | | Second and third letter prefix for construction feature, except single prefix | | Heat rating number | | First letter suffix for thread: reach | | Second letter suffix for construction feature, etc. | | |
|---|--------------|--------------|---|-------------------------------|--------------------|-------------|---------------------------------------|--------------|--|----------------------------|---|
| Letter | Thread size | Hexagon size | Letter | Construction feature | | Type | Letter | Thread reach | Letter | Construction feature, etc. | |
| A | 18 mm | 25.4 mm | B | Hexagon size 20.6 mm | 2 | Hotter | | None | A | -Specials | |
| B | 14 mm | 20.6 mm | C | Hexagon size 16.0 mm | 4 | | | | | B | -Special plug for Honda vehicles |
| C | 10 mm | 16.0 mm | G | Hexagon size 23.8 mm | 5 | | | | | C | -Competition type |
| D | 12 mm | 18.0 mm | L | Compact type (SHORTY) | 6 | | | | | G | -Racing plugs, center electrode of nickel alloy |
| F | 7/8 in-18 | 23.8 mm | M | Compact type (BANTAM) | 7 | | | | | GV | -Racing plugs, center electrode of precious metal |
| G | PF 1/2 in-14 | 23.8 mm | P | Projected insulator nose type | 8 | | | | | N | -Racing plugs, nickel electrode |
| | | | R | Resistor type | 9 | (85) | | | | P | -Racing plugs, platinum ground electrode |
| | | | S | Shielded type | 10 | (95) | | | | R | -Shielded resistor plugs |
| | | | U | Surface discharge type | 11 | (105) | | | | S | -Copper core center electrode (Super) |
| | | | | | 12 | | | | | V | -Center electrode of precious metal |
| | | | | | 13 | | | | | W | -Tungsten electrode |
| | | | | | 14 | Colder type | | | | X | -Series gap plugs |
| | | | | | | | | | | Y | -V-Grooved center electrode |
| | | | | | | | | | | F | Conical seat type |
| | | | | | | | | A - F | 10.9 MM | | |
| | | | | | | | | B - F | 11.2 MM | | |
| | | | | | | | | BM - F | 7.8 MM | | |
| | | | | | | | | BE - F | 17.5 MM | | |
| | | | | | | | | | Multiple ground electrodes type | | |
| | | | | | | | | | K 2 T 3 | | |
| | | | | | | | | | M 2 Q 4 | | |
| | | | | | | | | | Others Expect for above letters, there are special plugs of J, L, Z, etc | | |

*Standard regulation is drawn here. There also exist a few extraordinary symbol.

Wide gap type (mm)

A01E1GS

593 HO AND 793 HO ENGINE TYPES

REV Series

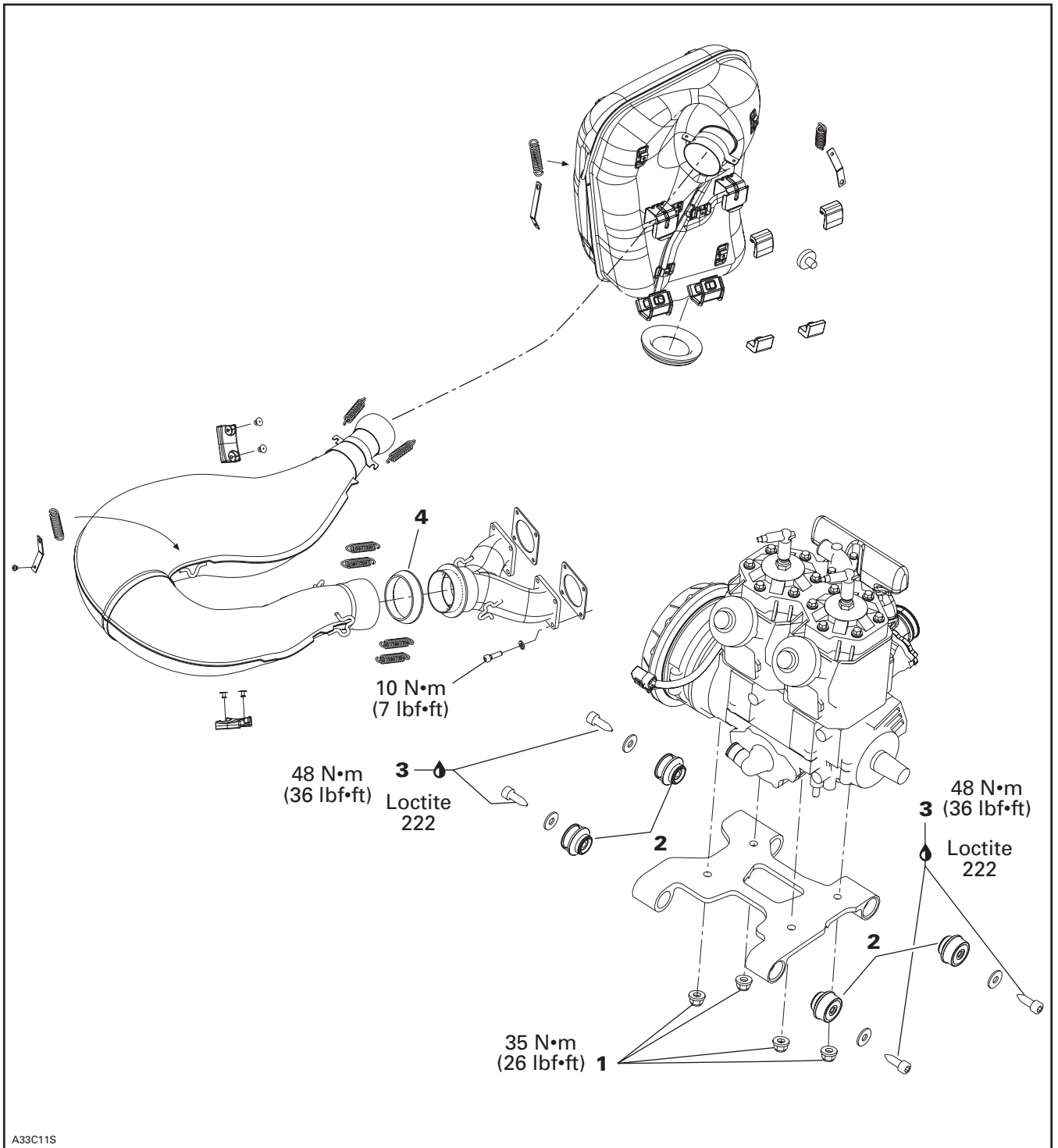

A33C11S

TYPICAL

SECTION 04 - ENGINE PREPARATION

MAINTENANCE

NOTE: Replace with new ones any damaged clamps. Refer to appropriate *Parts Catalogs* to order new clamps.

REMOVAL FROM VEHICLE

Open hood and side panels, refer to BODY.

Remove muffler, tuned pipe and exhaust manifold.

Drain engine coolant.

Remove or unplug the following then lift off engine from engine compartment.

NOTE: Use of a hoist is recommended.

- guard
- air silencer
- drive belt
- rewind starter handle
- drive pulley
(not necessary if engine does not have to be disassembled)
- hood and left side panels (if necessary for better access), refer to BODY
- carburetors and carburetor clamps
- impulse hose at engine and electrical connectors
- oil injection inlet line at oil injection pump, install hose pincher
- oil pump cable
- coolant hoses between cylinder head and radiator
- coolant by-pass hose
- coolant hose at front of coolant reservoir
- engine support screws
- engine stopper (left rear of engine)
- windshield (if required).

Remove spark plugs and install spark plug lift ring (P/N 529 035 830) at the farthest spark plug hole.

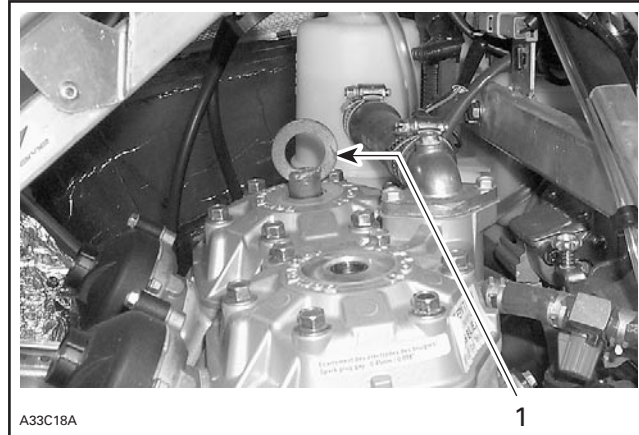

1. Spark plug lift ring

Lift and slide out engine using engine removal hook (P/N 529 035 829).



ENGINE REMOVAL

INSTALLATION

1,2,3, Engine Support Nut, Rubber Mount and Manifold Screw

Install and torque the engine/support nuts **no. 1** to 35 N•m (26 lbf•ft).

Torque screws **no. 3** to 48 N•m (35 lbf•ft) in rubber mount **no. 2**. Before installing screws **no. 3** apply loctite 222 (P/N 413 703 400) on them.

NOTE: Never replace the engine support rubber mount alone. Always replace the whole engine support assembly.

Torque manifold screws M6 to 10 N•m (89 lbf•in).

INSTALLATION ON VEHICLE

To install engine on vehicle, reverse removal procedure. However, pay attention, to all appropriate component/system reinstallation procedures described throughout this *Shop Manual* and to the following:

- After throttle cable installation, check carburetor maximum throttle opening and oil injection pump adjustment.
- Check pulley alignment and drive belt tension.

Install doughnut shaped exhaust gasket **no. 4** with both notches of its aligned with Y-manifold protrusions.

NOTE: No sealant required on doughnut shaped exhaust gasket **no. 4**.

SECTION 04 - ENGINE PREPARATION

TOP END

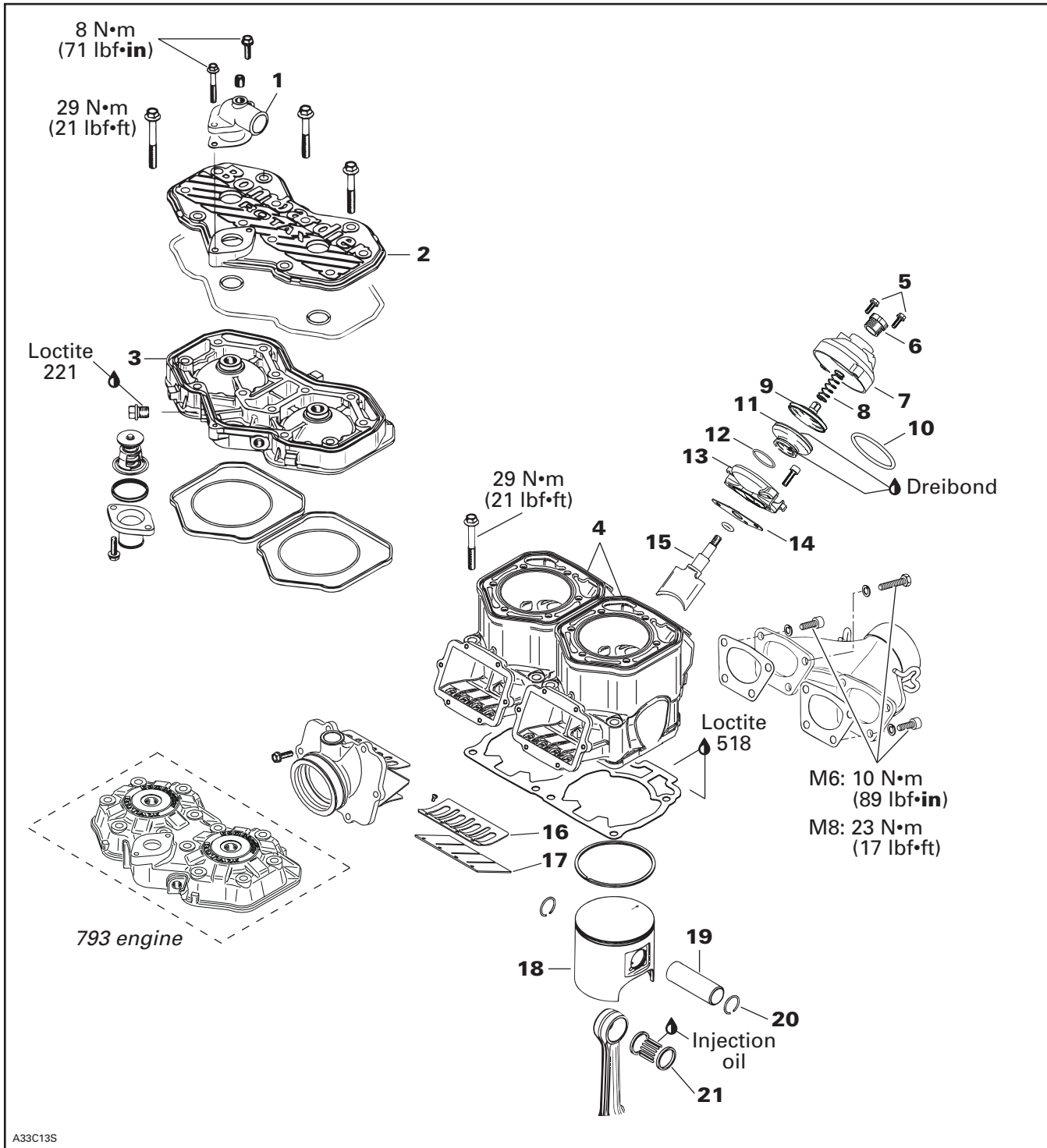

TROUBLESHOOTING

Before completely disassembling the engine, check airtightness. Refer to LEAK TEST AND ENGINE DIMENSION MEASUREMENT.

NOTE: The following procedures can be done without removing the engine from the chassis.

COMPONENT REMOVAL WITH THE ENGINE INSTALLED

Most engine components can be removed with engine on vehicle such as:

- cylinder head
- cylinder head cover
- piston(s)
- piston ring(s)
- cylinder(s)
- rewind starter
- oil pump
- water pump
- magneto flywheel
- RAVE valve(s)
- reed valve(s).

CLEANING

Discard all gaskets and O-rings.

Clean all metal components in a non-ferrous metal cleaner.

Scrape off carbon formation from cylinder exhaust port cylinder head and piston dome using a wooden spatula.

NOTE: The letters "AUS" (over an arrow on the piston dome) must be visible after cleaning.

Clean the piston ring groove with a groove cleaner tool or with a piece of broken ring.

DISASSEMBLY

RAVE System

NOTE: RAVE stands for Rotax Adjustable Variable Exhaust.

Remove spring clip or screws **no. 5**, cover **no. 7** and spring **no. 8**.

Remove spring **no. 10**.

Unscrew valve piston **no. 9**.

Remove bellows **no. 11** and spring **no. 12**.

Remove cylindrical screws. Remove valve housing **no. 13**.

Pull out exhaust valve **no. 15**.

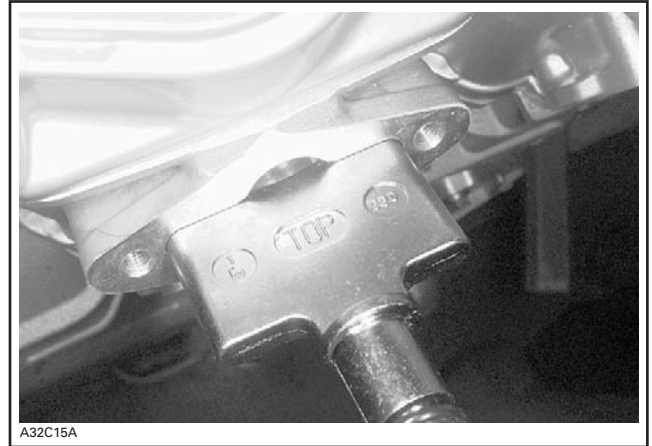

RAVE VALVE PARTIALLY REMOVED

2, Cylinder

Remove spark plugs, coolant outlet **no. 30**. Unscrew cylinder head cover **no. 2** then cylinder head **no. 3**.

18, Piston

Place a clean cloth or rubber pad (P/N 529 023 400) over crankcase. Then with a pointed tool inserted in piston notch, remove both circlips **no. 20** from piston **no. 18**.

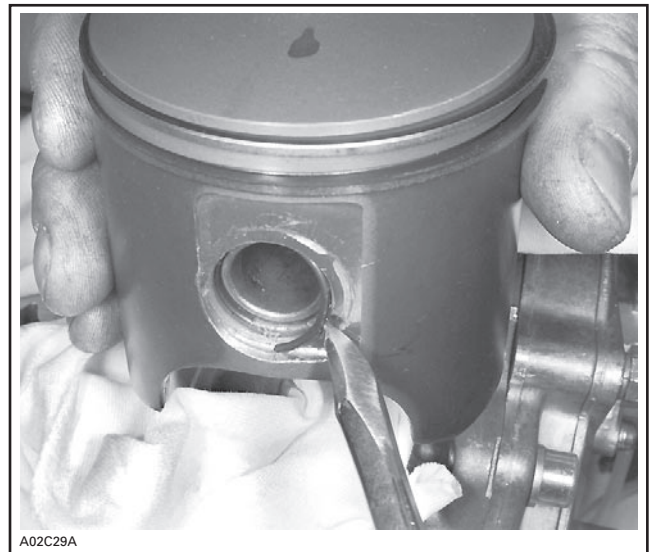

TYPICAL

SECTION 04 - ENGINE PREPARATION

All engines are equipped with cageless piston pin bearings.

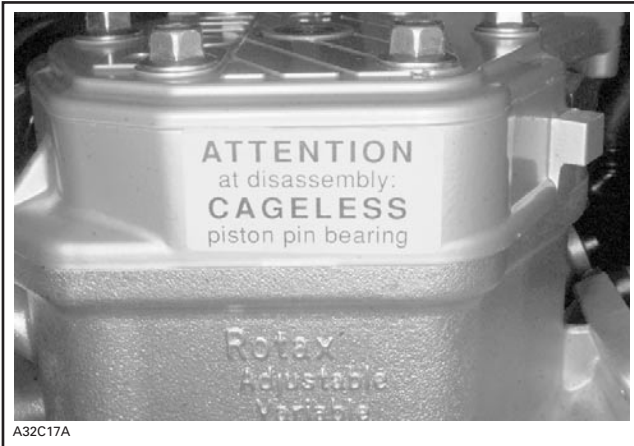

Use piston pin puller (P/N 529 035 503) along with 20 mm sleeve kit (P/N 529 035 542). Use also a locating sleeve.

NOTE: The locating sleeve is the same that contains new cageless bearing.

Insert piston pin puller (P/N 529 035 503) making sure it sits squarely against piston.

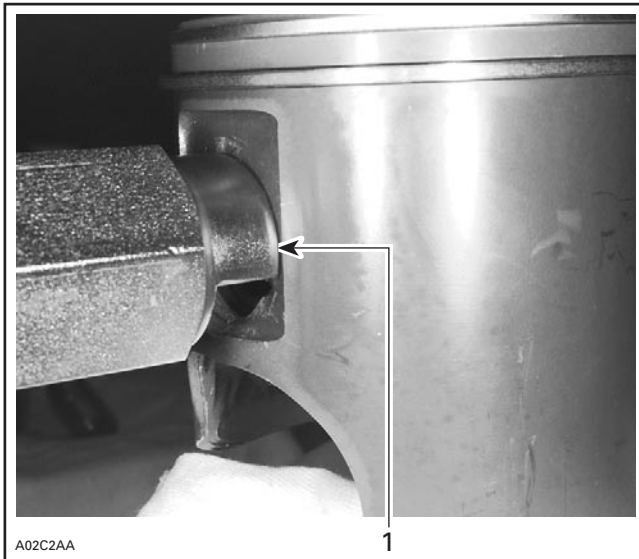

TYPICAL

1. Properly seated all around

Install sleeve then shouldered sleeve over puller rod.

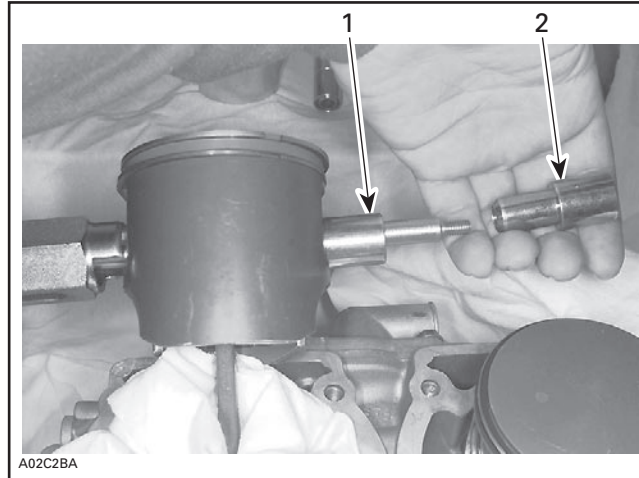

TYPICAL — INSTALLATION OF SLEEVE KIT

1. Sleeve
2. Shouldered sleeve

Screw (LH threads) extracting nut.

Pull out piston pin no. 19 by unscrewing puller until shouldered sleeve end is flush with thrust washer of piston pin bearing.



TYPICAL — PISTON PIN EXTRACTION

SECTION 04 - ENGINE PREPARATION

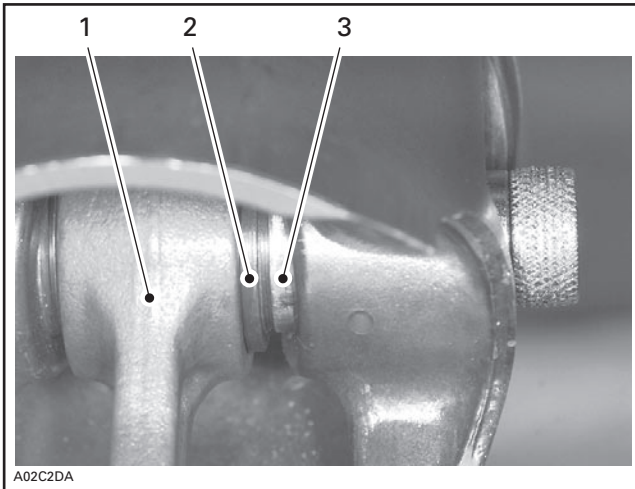

TYPICAL

1. Sleeve inside bearing
2. Thrust washer
3. Shouldered sleeve end

Remove puller. Pull out shouldered sleeve carefully.

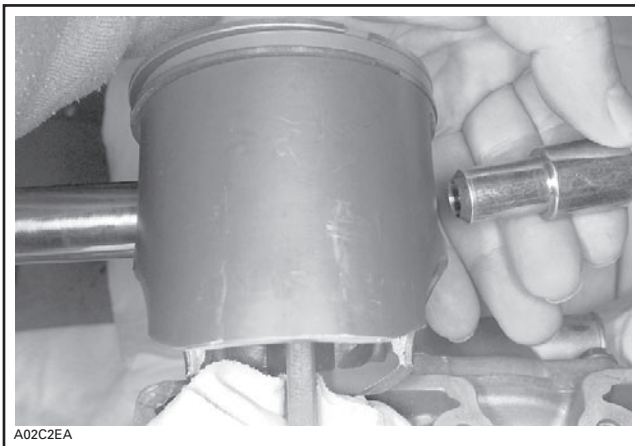

TYPICAL

Remove piston from connecting rod.
Install locating sleeve. Then push needle bearings along with thrust washers and sleeve.

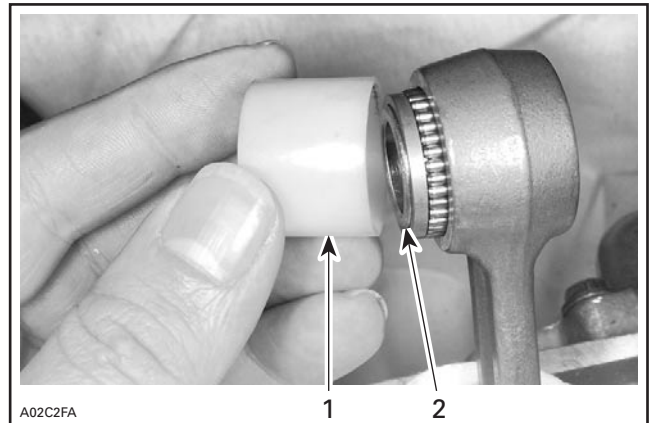

TYPICAL

1. Locating sleeve
2. Sleeve

INSPECTION

NOTE: Refer to LEAK TEST AND ENGINE DIMENSIONS MEASUREMENT.

RAVE System

Check valve rod housing and cylinder for clogged passages.

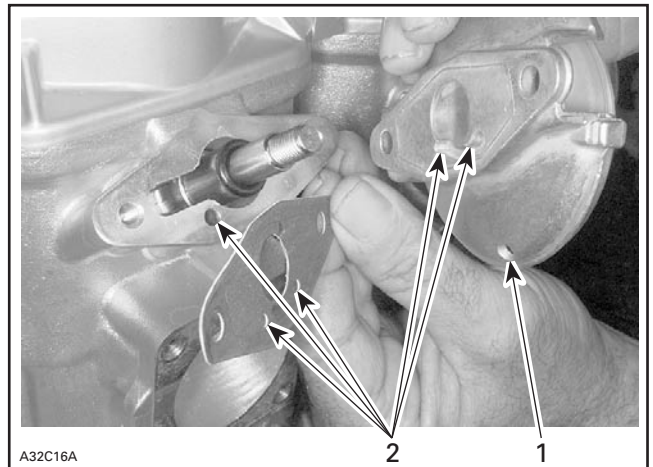

1. Draining hole
2. Passages

NOTE: Oil dripping from draining hole indicates a loosen spring or damaged bellows.

SECTION 04 - ENGINE PREPARATION

11, Bellows

Check for cracked, dried or perforated bellows.

8, Spring

| ENGINE TYPE | SPRING P/N | COLOR | WIRE DIA. mm (in) | FREE LENGTH mm (in) | PRELOAD IN N (LBF) AT COMPRESSED LENGTH OF 14 mm (.551 in) |
|-------------|-------------|--------|-------------------|---------------------|--|
| 593 HO | 420 239 944 | Brown | 0.9 (.035) | 48.5 (1.91) | 15.9 (3.56) |
| 793 HO | 420 239 940 | Yellow | 0.8 (.031) | 48.5 (1.91) | 10.5 (2.36) |

ASSEMBLY

RAVE System

Install RAVE valve with its mention top as illustrated in the removal photo. Tighten red cap **no. 6** screw to bottom.

4,18, Cylinder and Piston

Before inserting piston in cylinder, lubricate the cylinder with new injection oil or equivalent.

2,3,4, Cylinder Head Cover, Cylinder Head and Cylinder

Make sure parts sealing surfaces are flat. Refer to LEAK TEST AND ENGINE DIMENSION MEASUREMENT and look for CYLINDER HEAD WARPAGE.

When installing a new cageless bearing, replace half plastic cages with sleeve.

NOTE: 593 HO, and 793 engine cageless bearings have 28 needles.

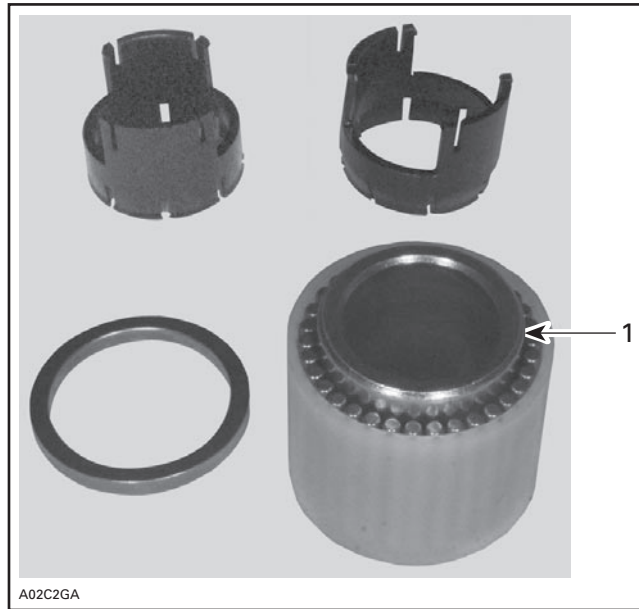

TYPICAL

1. Sleeve

Oil needle bearing with injection oil. Grease thrust washers and install them on each end of needles.

Insert cageless bearing into connecting rod.



TYPICAL — CAGELESS BEARING AND SLEEVE INSTALLED

Heat piston with a 100 W lamp or a heat gun before piston installation.

CAUTION: Piston temperature must not exceed 46°C (115°F). Never use direct flame to heat the piston and never freeze the pin.

SECTION 04 - ENGINE PREPARATION

At assembly, place the pistons over the connecting rods with the letters "AUS" (over an arrow on the piston dome) facing towards the exhaust port.

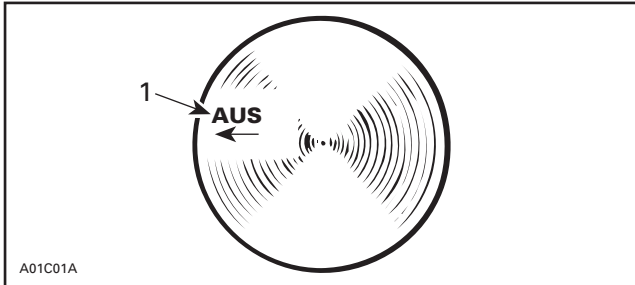

1. Exhaust

Install shouldered sleeve.



TYPICAL — SHOULDERED SLEEVE INSTALLATION

Install piston pin puller and turn handle until piston pin is correctly positioned in piston.

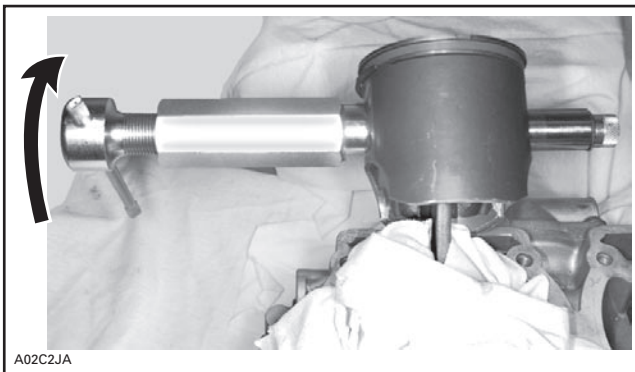

TYPICAL

All Models

CAUTION: Always install new circlips.

To minimize the effect of acceleration forces on circlip, install each circlip so the circlip break is at 6 o'clock as illustrated. Use appropriate piston circlip installer.

| ENGINE TYPE | PISTON CIRCLIP INSTALLER (P/N) |
|-------------|--------------------------------|
| All | 529 035 686 |

Use circlip installer (P/N 529 035 686) to install new mono-hook circlips **no. 20**.

Insert circlip into support so that, when installed in piston groove, the tab faces upward.



With round end of pusher, position circlip perpendicularly to the support axis.

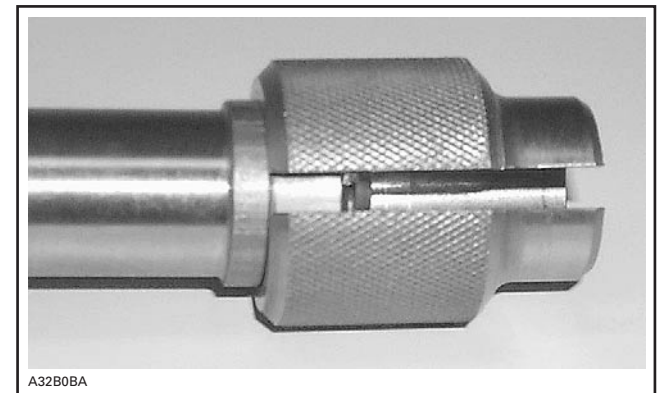

SECTION 04 - ENGINE PREPARATION

With the other end of the pusher, push circlip into the support groove.

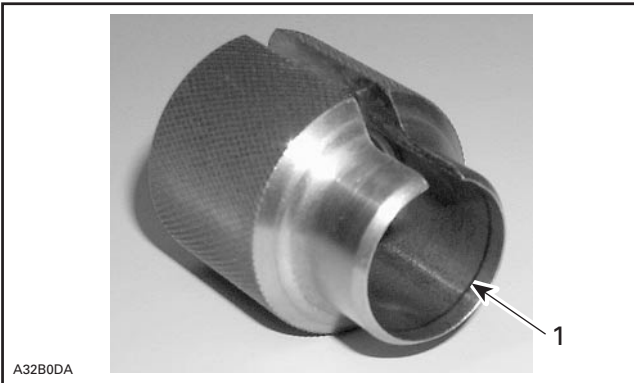

CIRCLIP READY TO BE INSTALLED ON PISTON

Using a plastic hammer, tap pusher to put circlip in place. Make sure to install new circlips with tab toward top as per following photo.

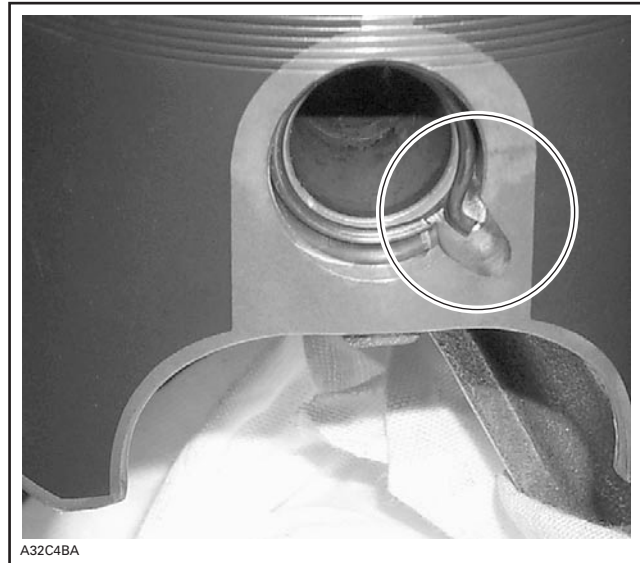

TAB TOWARD TOP

CAUTION: Always install new mono-hook circlips. If circlip installation fails at the first attempt, always retry with a new one because, on a second attempt, the circlip will lose its normal retaining capabilities.

CAUTION: Circlips must not move freely after installation; if so, replace them.

Clean cylinders and crankcase mating surfaces with Loctite Chisel (P/N 413 708 500).

Coat crankcase mating surface with Loctite 518 (P/N 293 800 038). Choose the right gasket thickness according to combustion chamber volume. Refer to LEAK TEST AND ENGINE DIMENSION MEASUREMENT. Install it on crankcase. Coat gasket with Loctite 518.

CAUTION: Always install a gasket of the proper thickness. Failure to do so may cause detonation and severe engine damage.

Before inserting piston in cylinder, lubricate the cylinder with new injection oil or equivalent.

Install cylinders. Do not tighten.

Install new rubber ring and round O-rings on each cylinder.

NOTE: Carefully clean screws before reinstallation, specifically under screw head.

Install exhaust manifold with gaskets. Do not tighten yet.

Torque cylinder screws in a crisscross sequence as per the following table.

| | |
|-----|--------------------|
| M8 | 29 N•m (21 lbf•ft) |
| M10 | 40 N•m (29 lbf•ft) |

At assembly, torque cylinder head screws to 29 N•m (21 lbf•ft) in the following illustrated sequence.

Tighten exhaust manifold bolts to 23 N•m (17 lbf•ft) in a criss-cross sequence.

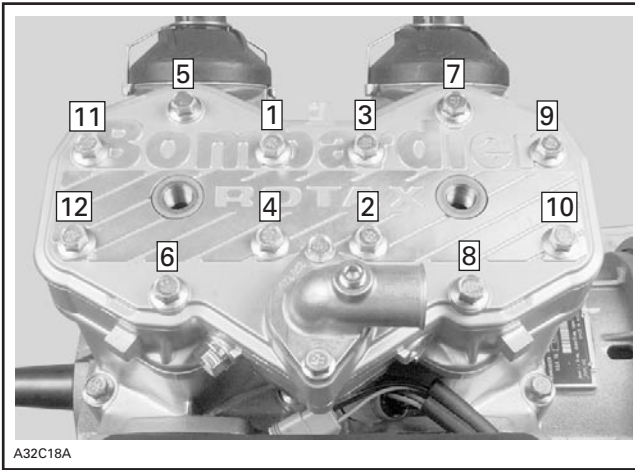

A32C18A

TYPICAL

Apply Loctite 243 (P/N 293 800 060) on screws threads. Install outlet socket and tighten screws to 12 N•m (106 lbf•in). Note position of longer screw.

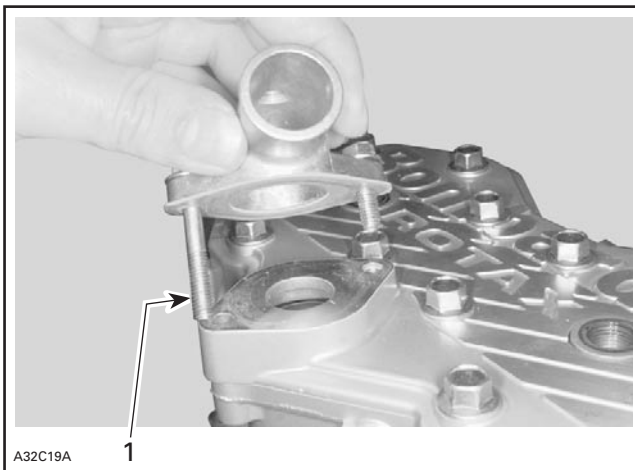

A32C19A

1. Longer screw

17, Reed Valve

All Engines

Blades have a curved shape. Install with their curve facing reed block.

With blade stopper no. 16 removed, check reed valve for proper tightness. There must not be any play between blade and valve body when exerting a finger pressure on blade at blade stopper location.

In case of a play, turn blade upside down and re-check. If there is still a play, replace blade and/or valve body.

Check distance from blade stopper outer edge and distance from center of reed valve block.

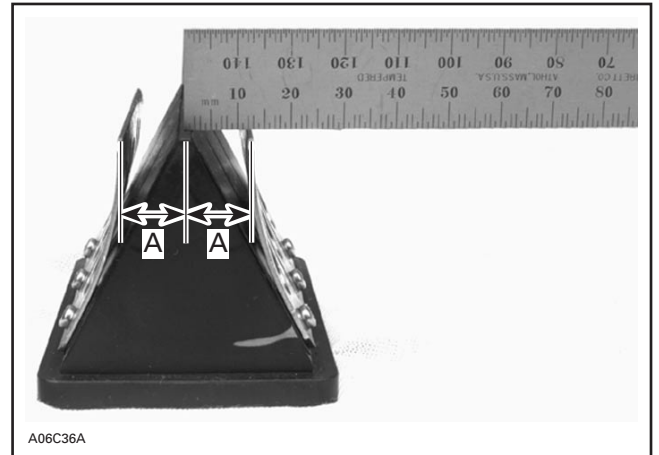

A06C36A

TYPICAL

A. 18.7 - 0, + 0.75 mm (.736 - 0, + .030 in)

Bent blade stopper as required to obtain the proper distance.

Blade stoppers may slightly interfere with cylinder during installation. Adjusted distance will be reduced automatically upon installation.

SECTION 04 - ENGINE PREPARATION

BOTTOM END

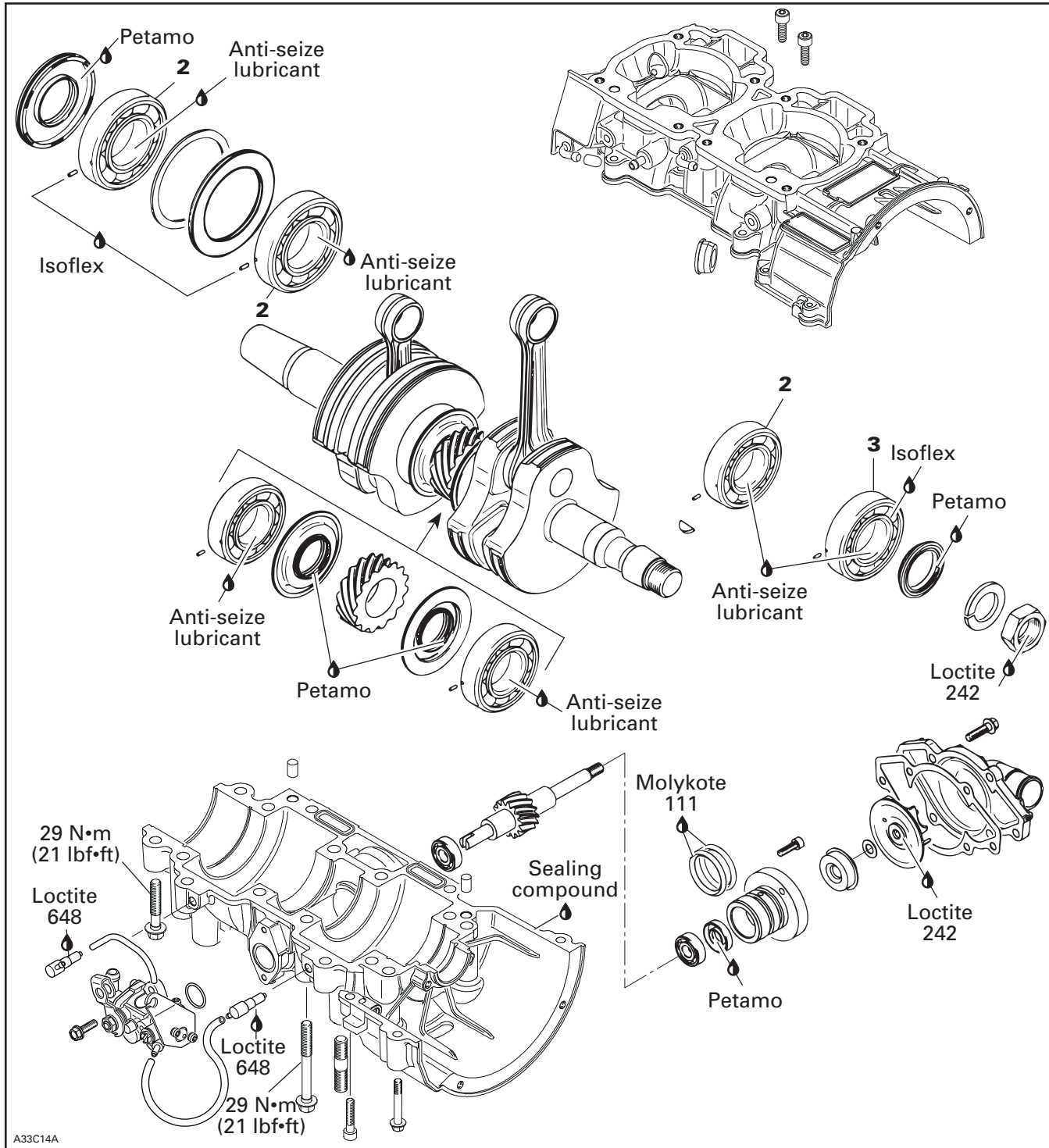

A33C14A

NOTE: Engine must be removed from chassis to perform the following procedures.

CLEANING

Discard all oil seals, gaskets, O-rings and sealing rings.

Clean all metal components in a non-ferrous metal cleaner. Use Gasket remover (P/N 413 708 500) accordingly.

Remove old paste gasket from crankcase mating surfaces with Gasket remover (P/N 413 708 500).

CAUTION: Never use a sharp object to scrape away old sealant as score marks incurred are harmful to crankcase sealing.

DISASSEMBLY

General

To remove drive pulley, refer to DRIVE PULLEY.

To remove magneto, refer to CDI SYSTEM.

2,3, Crankshaft Bearing

To remove bearings from crankshaft, use a protective cap and special puller, as illustrated.

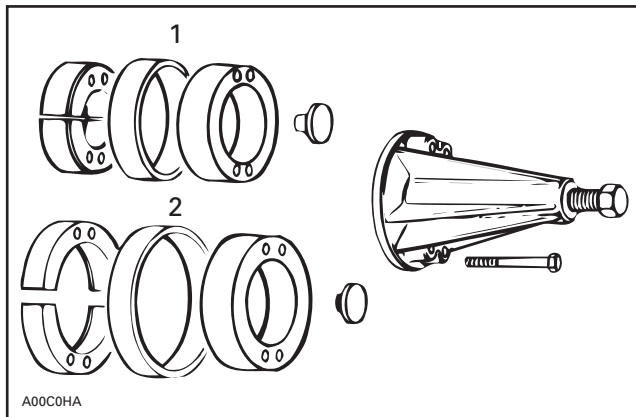

1. PTO side
2. MAG side

INSPECTION

NOTE: Refer to LEAK TEST AND ENGINE DIMENSIONS MEASUREMENT.

ASSEMBLY

Coat lip of all seals with Petamo grease (P/N 420 899 271).

2, Crankshaft Bearing

Smear anti-seize lubricant (P/N 413 701 000) on part of crankshaft where bearing fits.

Prior to installation, place bearings into an oil container filled with injection oil previously heated to 75°C (167°F). This will expand bearing and ease installation.

Some bearings must be lubricated with Isoflex grease (P/N 293 550 021).

CAUTION: Use only the recommended Isoflex grease. Make sure not to push Isoflex grease between outside bearing race and half crankcase.

NOTE: The 50 g tube corresponds to 50 cc of grease.

Put 50 to 55 mL of grease in a syringe.

CAUTION: Do not exceed the recommended amount of grease.

Fill inner side of PTO side bearing with Isoflex grease (about 10 mL).

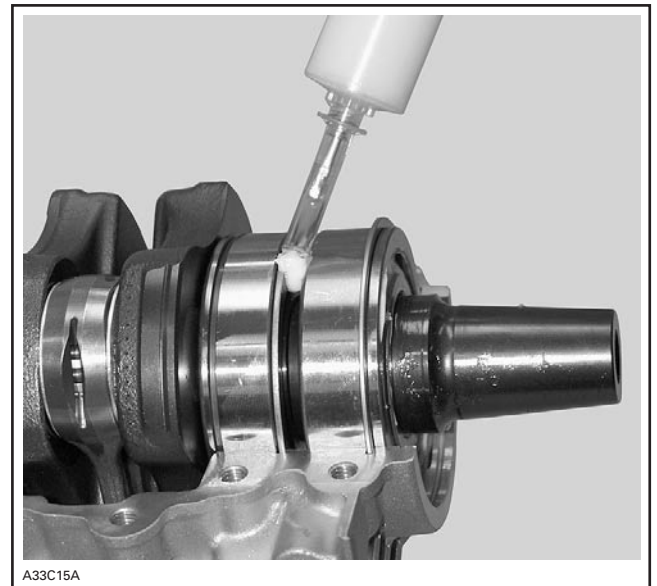

PTO SIDE BEARING FILLED WITH ISOFLEX GREASE

SECTION 04 - ENGINE PREPARATION

With the syringe, fill the outer ball bearing and inner side of outer seal with 40 to 45 mL of Isoflex grease.



BALLS COATED WITH A SEAM OF GREASE

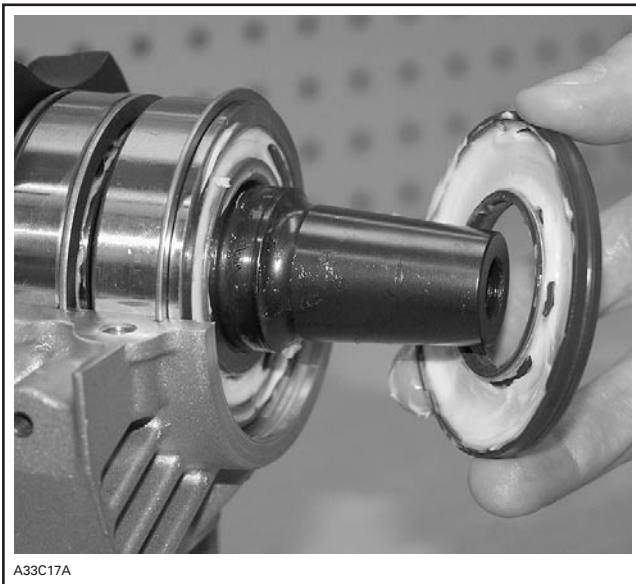

FILL WITH GREASE AND SET IN PLACE

Apply 6 mL of grease to MAG side outer bearing.

NOTE: If replaced with new bearing, do not apply grease as new bearings come with grease already applied.

At crankshaft installation, position drive pins as illustrated.

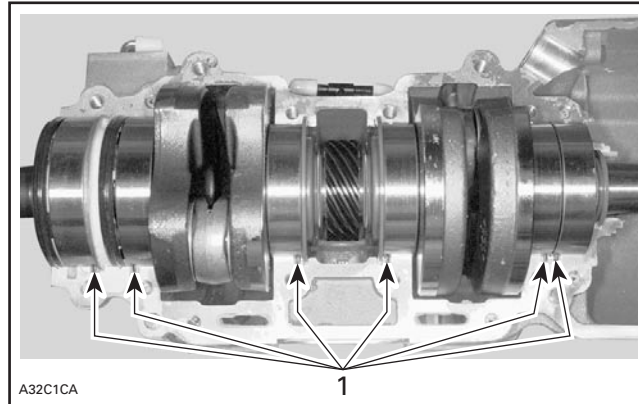

TYPICAL

1. Position pins

Pour 50 mL (2 U.S. oz) of injection oil in the pan under central gear to lubricate pump gearing as per photo.

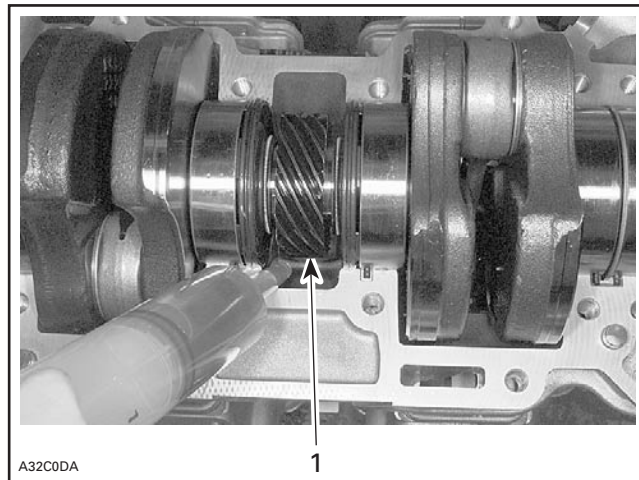

1. Oil bath

Crankcase Assembly

IMPORTANT: The total assembly sequence, including sealing compound spreading, screwing and torquing of bolts according to the proper sequence, must be performed within 10 minutes. **Do not wait between each bolt torquing. All bolts must be torqued in a row.**

Before screwing both parts of crankcase, seal it with sealing compound (P/N 420 297 906). Make sure surfaces are clean and degreased before applying sealing compound.

Spread a seam of 1.2 mm (1/16 in) maximum in diameter on surface of lower crankcase half.

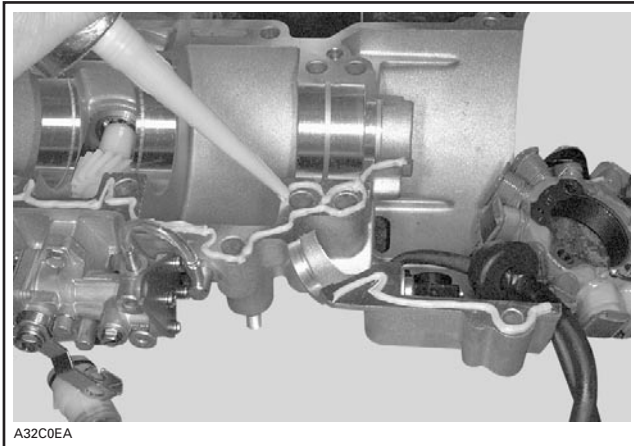

As far as possible, sealing compound must be applied in one run to avoid any risks of leakage through the crankcase.

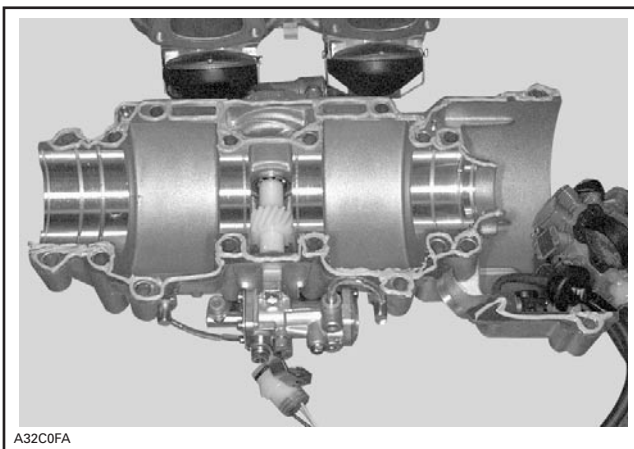

SEAMING COMPLETED — CONTACT SURFACES COVERED AND SCREW HOLES SURROUNDED

Screw all crankcase bolts in place in the following sequence and to the appropriate torque; this must be done in two steps torquing: first, screw bolts up to 60% of the final torque (18 N•m (13.5 lbf•ft) for most of the bolts), then, tighten to the required torque (i.e. 29 N•m (21 lbf•ft)).

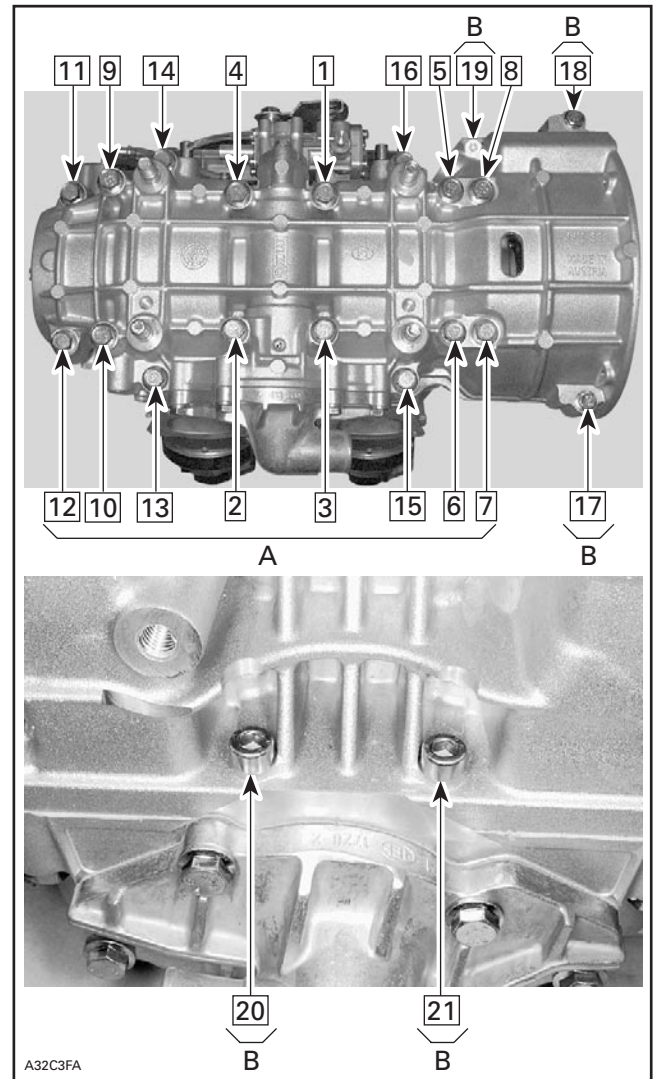

A. Torque bolts 1 through 16 to 29 N•m (21 lbf•ft)
 B. Torque bolts 17 through 21 to 9 N•m (80 lbf•in)

BREAK-IN

After rebuilding an engine, always observe a break-in period as described in *Operator's Guide*.

LEAK TEST AND ENGINE DIMENSION MEASUREMENT

The following gives verification procedures for 593 HO and 793 types of engines.

PREPARATION

1. Remove tuned pipe.
2. Install plug over exhaust manifold.
3. Remove carburetors.
4. Insert plugs in intake rubber boots. Tighten with existing clamps.

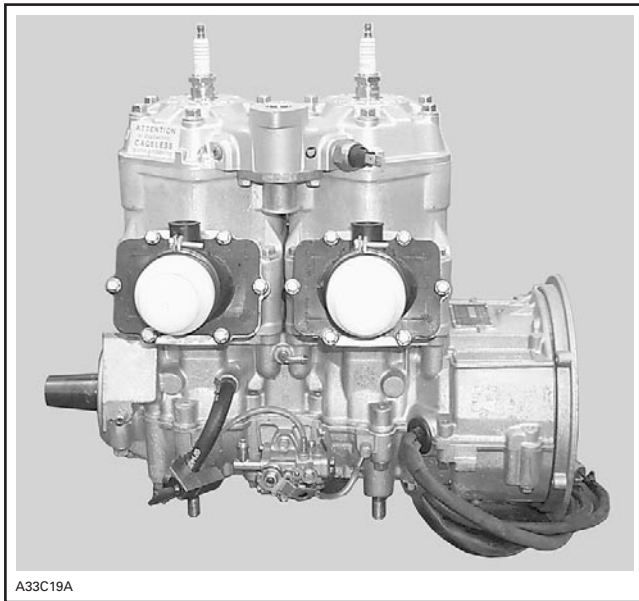

5. Using a hose pincher (P/N 295 000 076), block impulse hose.
6. Install air pump on exhaust plug.

NOTE: If necessary, lubricate air pump piston with mild soap.

CAUTION: Using hydrocarbon lubricant (such as engine oil) will damage rubber seal of pump piston.

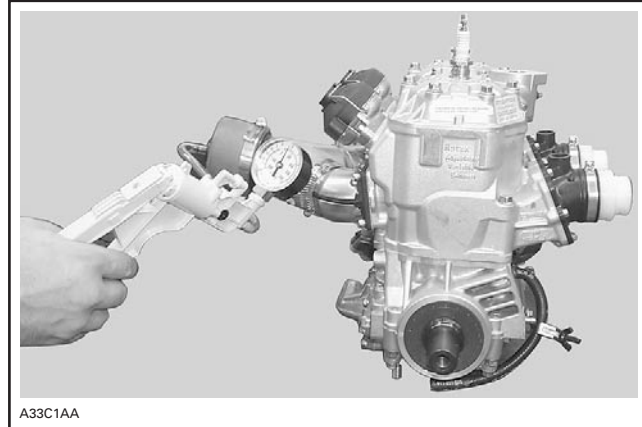

7. Activate pump and pressurize engine to 34 kPa (5 PSI). Do not exceed this pressure.
8. Engine must stand this pressure during 3 minutes. If pressure drops before 3 minutes, check tester kit by spraying a soapy solution on pump cylinder, all plugs and fittings.
 - If tester kit is leaking, bubbles will indicate where leak comes from.
 - If tester kit is not leaking, check engine as per following procedure.

PROCEDURE

NOTE: A flow chart has been prepared as a visual reference. See last page of this chapter.

Using flow chart and following text, pressurize area to be tested and spray soapy solution at the indicated location.

**TEST PRESSURE: 34 kPa (5 PSI)
for 3 minutes**

- If there is a leak at the tested location, it is recommended to continue testing next items before overhauling engine. There is a possibility of more than one leak.
- If there is no leak at the tested location, continue pumping to maintain pressure and continue with next items until leak is found.

Engine

Check the following:

1. All jointed surfaces and screw/stud threads of engine:
 - spark plug base, insulator
 - cylinder head
 - RAVE valve bellows, piston and housing
 - cylinder
 - crankcase halves (joint)
 - oil injection pump mounting flange (O-ring)
 - coolant pump housing
 - bleed screws/plugs.
2. Small injection oil lines coming from pump.

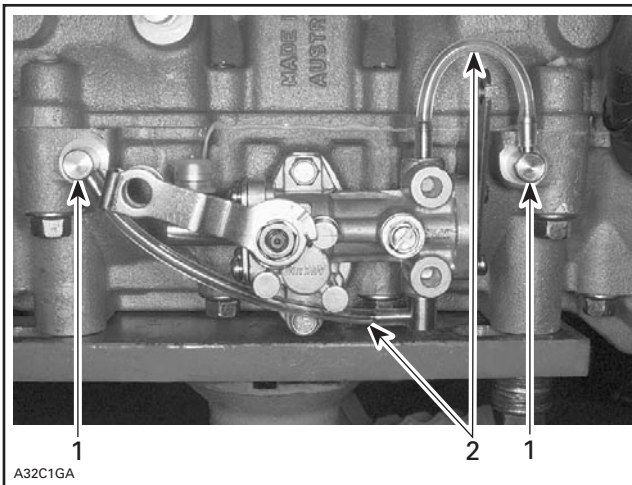

1. Injection nipples
2. Small injection oil lines

Check for air bubbles or oil column going toward pump. It indicates defective check valve in injection nipples.

3. Remove cooling system cap.

Check for air bubbles in antifreeze. It indicates defective cylinder head O-ring or cylinder base gasket.

4. Remove drive pulley then check crankshaft outer seal.
5. Remove rewind starter and magneto system then check crankshaft outer seal.
6. Check pump shaft gear oil reservoir.

Pump Shaft Oil Gear Reservoir

Install air pump on adapter and pressurize as above.

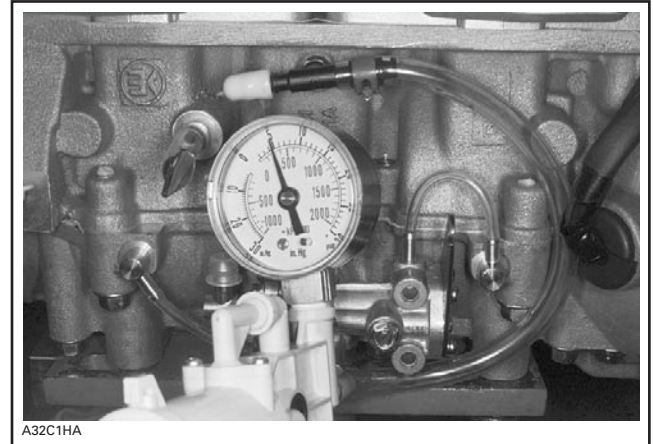

If pressure drops, it indicates a defective crankshaft inner seal.

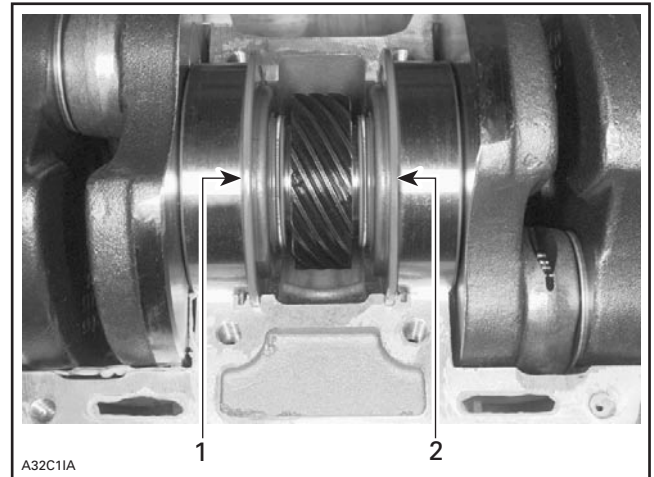

CRANKSHAFT INSTALLED IN UPPER HALF CRANKCASE

1. Crankshaft inner seal on PTO side
2. Crankshaft inner seal on MAG side

SECTION 04 - ENGINE PREPARATION

1. Check weep hole below coolant pump housing with soapy water.

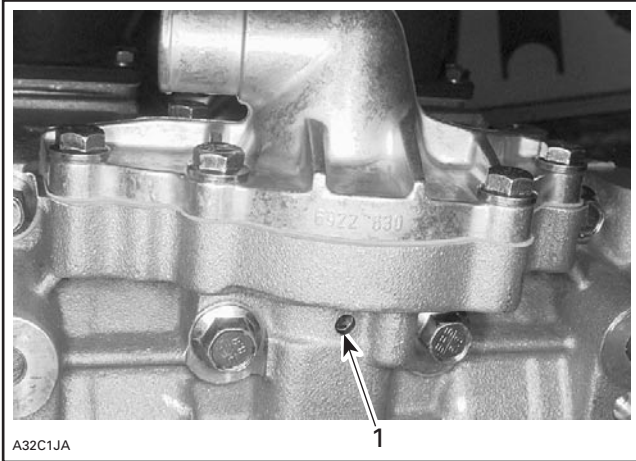

1. *Weep hole*

If there is a leak, it indicates that a pump shaft is defective (oil seal beside coolant ceramic seal).

2. Leaks can be also on oil pump side. Check mounting area for leaks.

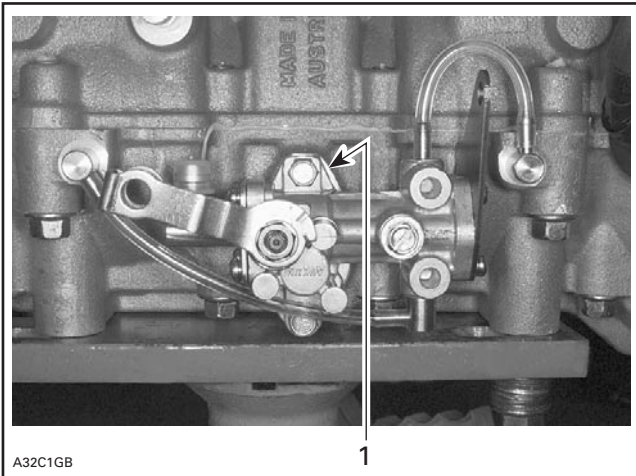

1. *Check mounting area*

3. If leak still persists, it indicates a defective casting somewhere in engine.

Disassemble engine and carefully check for defects in castings. Pay attention to tapped holes which may go through engine sealed area and thus lead to leakage.

FINALIZING REASSEMBLY

After reassembling engine, always recheck for leakage.

ENGINE LEAK VERIFICATION FLOW CHART

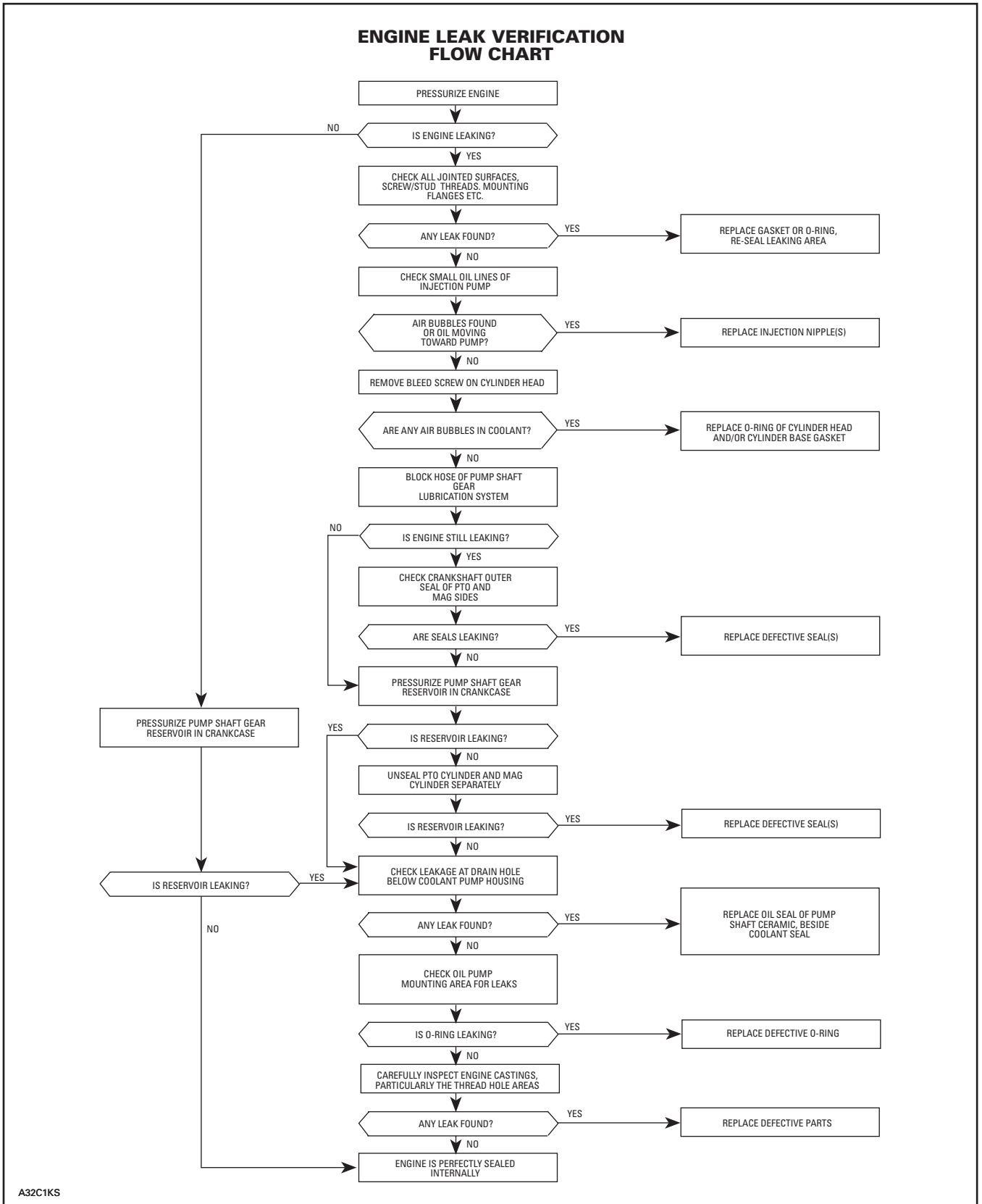

A32C1KS

SECTION 04 - ENGINE PREPARATION

ENGINE DIMENSION MEASUREMENT

This section covers all engine types.

CYLINDER HEAD WARPAGE

| ENGINE TYPE | MAXIMUM |
|-------------|--|
| All | 0.05 mm (.002 in) per 50 mm (2 in) of surface |
| | 0.5 mm (.020 in) for total length of cylinder head |

Check gasketed surface of the cylinder head with a straightedge and a feeler gauge.

CYLINDER TAPER

| ENGINE TYPE | MAXIMUM |
|-------------|-------------------|
| All | 0.10 mm (.004 in) |

Compare cylinder diameter 16 mm (5/8 in) from top of cylinder to just below its intake port area.

If the difference exceeds the specified dimension the cylinder should be rebored and honed or should be replaced. Nikasil cylinder can be honed using diamond hone but can not be rebored.

NOTE: Be sure to restore the chamfer around all cylinder sleeve port openings.

CYLINDER OUT OF ROUND

| ENGINE TYPE | MAXIMUM |
|-------------|-------------------|
| All | 0.08 mm (.003 in) |

Measuring 16 mm (5/8 in) from top of cylinder with a cylinder gauge, check if the cylinder out of round is more than the specified dimension. If larger, cylinder should be rebored and honed or should be replaced. Nikasil cylinder can be honed using diamond hone but cannot be rebored.

NOTE: Be sure to restore the chamfer around all cylinder sleeve port openings.

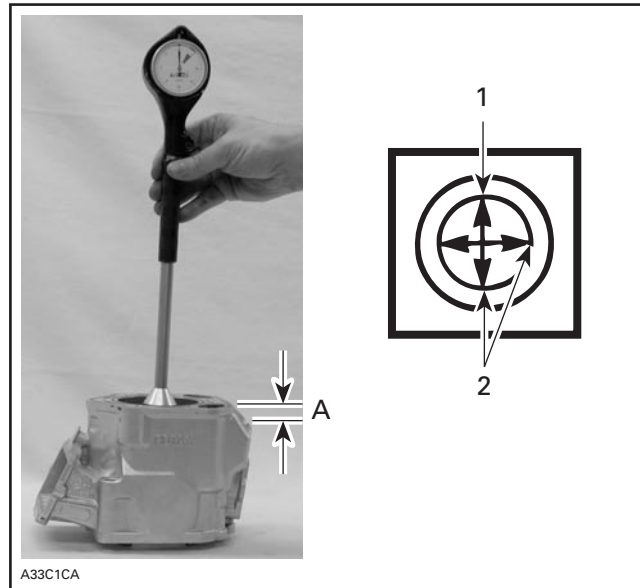

1. Piston pin position
2. Measures to be compared
- A. 16 mm (5/8 in)

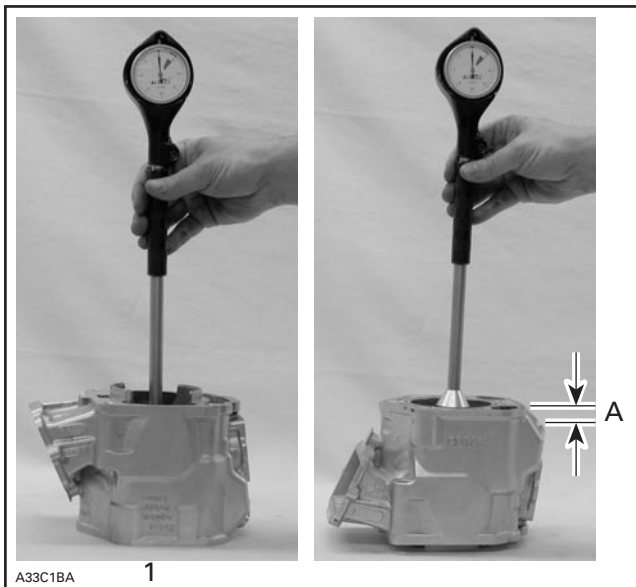

1. Below the intake port
- A. 16 mm (5/8 in) from top

COMBUSTION CHAMBER VOLUME MEASUREMENT

The combustion chamber volume is the region in the cylinder head above the piston at Top Dead Center. It is measured with the cylinder head installed on the engine.

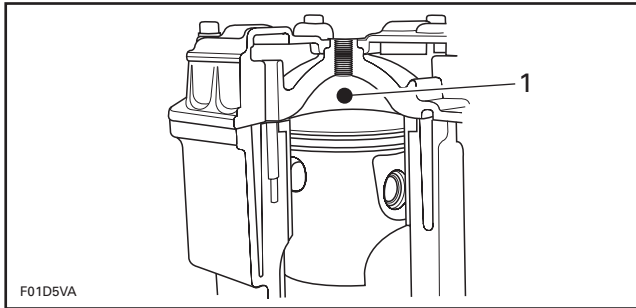

1. Combustion chamber

NOTE: When checking the combustion chamber volume, engine must be cold, piston must be free of carbon deposits and cylinder head must be leveled.

1. Remove both spark plugs and bring one piston to Top Dead Center using a TDC gauge.

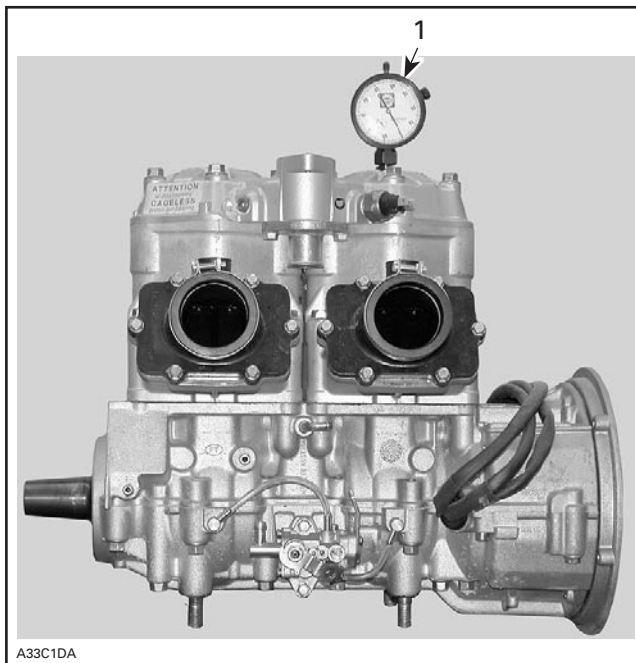

1. Bring piston to TDC

2. Remove cylinder head.
3. Seal piston ring gap with a small amount of grease.
4. Reinstall cylinder head.
5. Obtain a graduated burette (capacity 0 - 50 cc) and fill with an equal part (50/50) of gasoline and injection oil.

MMC2004-001_04A.FM

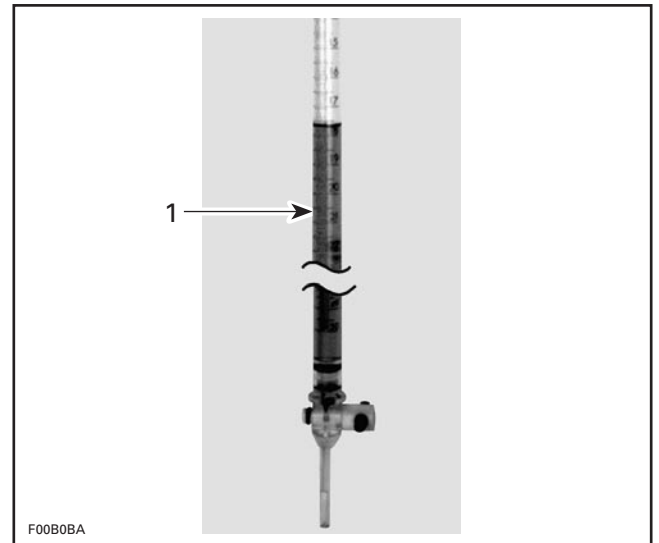

1. Graduated burette (0 - 50 cc)

6. Open burette valve to fill its tip. Add liquid in burette until level reaches 0 cc.
7. Inject the burette content through the spark plug hole until liquid touches the top spark plug hole.

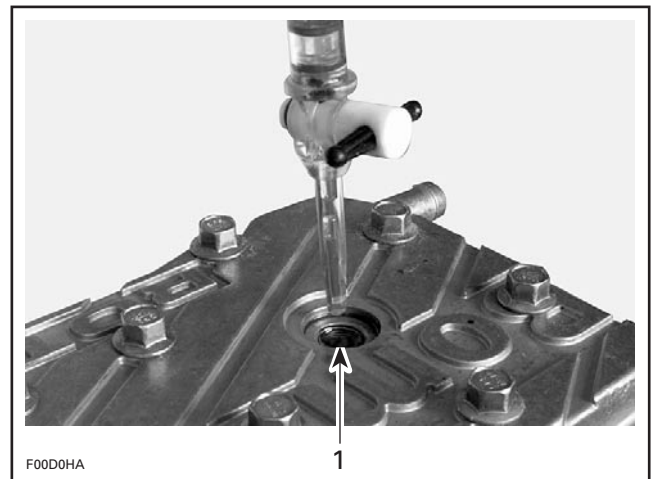

1. Top of spark plug hole

NOTE: The liquid level in cylinder must not drop for a few seconds after filling. If so, there is a leak between piston and cylinder. The recorded volume would be false. Reseal the piston ring gap and follow the instruction provided above.

8. Let burette stand upward for about 10 minutes, until liquid level is stabilized.
9. Read the burette scale to obtain the quantity of liquid injected in the combustion chamber.

NOTE: When the combustion chamber is filled to top of spark plug hole, it includes an amount of 2.25 cc corresponding to the spark plug well.

SECTION 04 - ENGINE PREPARATION

10. Repeat the procedure for the other cylinder.

| ENGINE TYPE | COMBUSTION CHAMBER VOLUME (cc) (up to top thread of spark plug hole) |
|-------------|--|
| 593 HO | 28.65 ±1.2 |
| 793 HO | 38.6 + 1.7, - 1.6 |

11. Install a thicker or thinner cylinder/crankcase gasket (refer to *Parts Catalogs*) in order to obtain the specified combustion chamber volume or the nearest.

| ENGINE TYPE | CHANGE IN COMBUSTION CHAMBER VOLUME (cc) FOR EVERY 0.1 mm (.004 in) OF GASKET THICKNESS |
|-------------|---|
| 593 HO | 0.41 |
| 793 HO | 0.53 |

USED PISTON MEASUREMENT

Note the measurement on the piston dome.

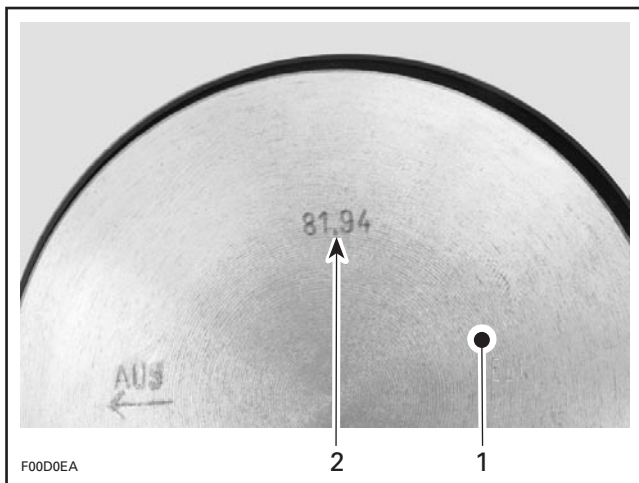

1. Piston dome
2. Piston measurement

Using a micrometer, measure piston skirt at 15 mm (.590 in) perpendicularly (90°) to piston pin.

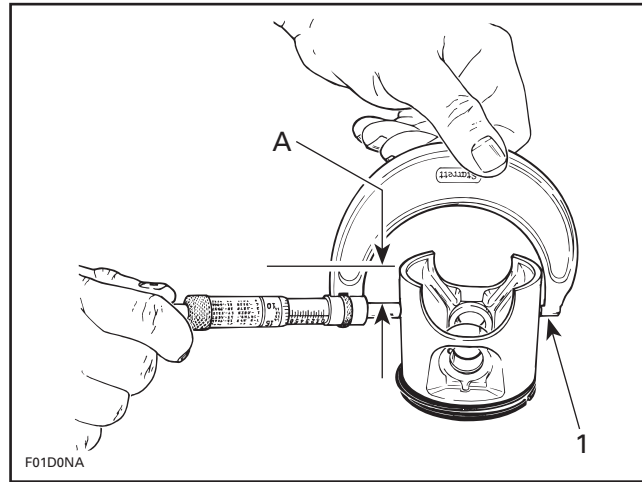

1. Measuring perpendicularly (90°) to piston pin axis
- A. 15 mm (.590 in)

| ENGINE TYPE | MAXIMUM PISTON SKIRT WEAR mm (in) |
|-------------|-----------------------------------|
| All | 0.15 (.006) |

The measured dimension must not be less than 0.15 mm (.006 in) of the one scribed on piston dome. Otherwise, install a new piston.

CYLINDER/PISTON CLEARANCE

Used and New Pistons

IMPORTANT: Make sure used piston is not worn more than specified. See USED PISTON MEASUREMENT above.

Take the measurement on the piston dome.

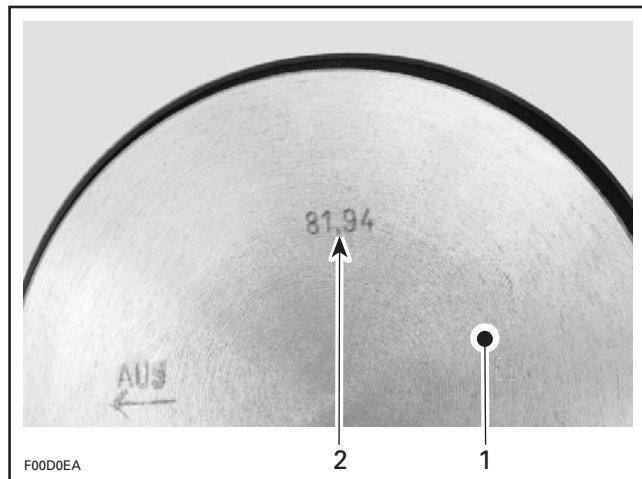

1. Piston dome
2. Piston measurement

SECTION 04 - ENGINE PREPARATION

Adjust and lock a micrometer to the specified value on the piston dome.

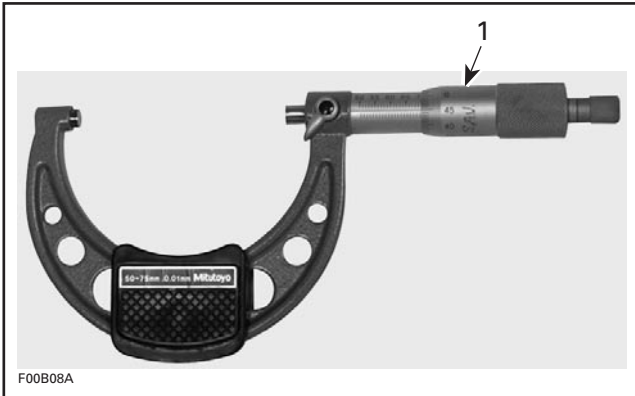

1. Micrometer set to the piston dimension

With the micrometer set to the piston dimension, adjust a cylinder bore gauge to the micrometer dimension and set the indicator to 0.

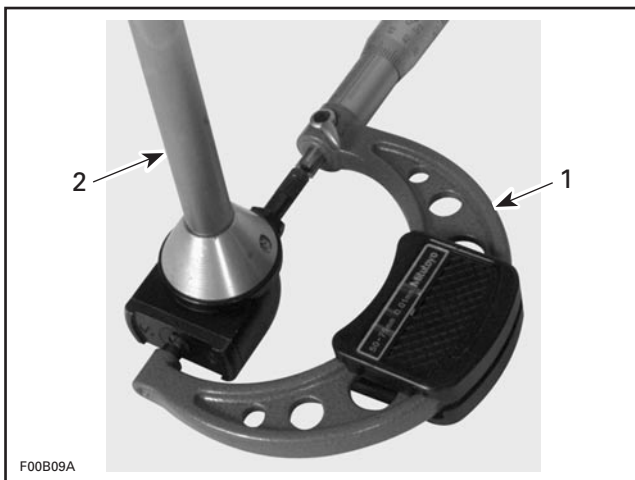

1. Use the micrometer to set the cylinder bore gauge
2. Dial bore gauge

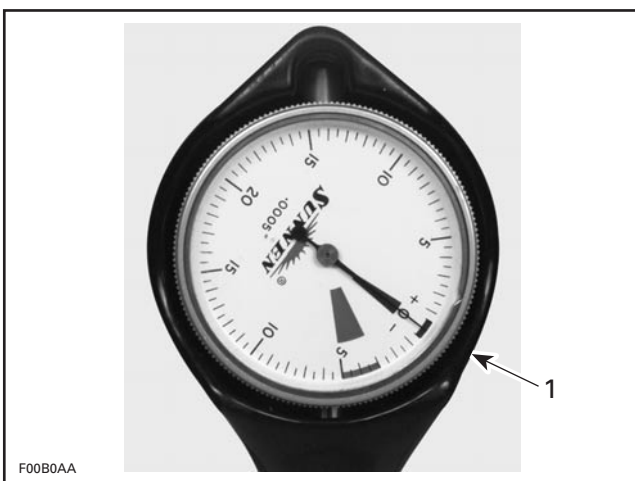

1. Indicator set to 0 (zero)

IMPORTANT: Always remove cylinders from crankcase before measuring.

Position the dial bore gauge at 16 mm (5/8 in) below cylinder top edge.

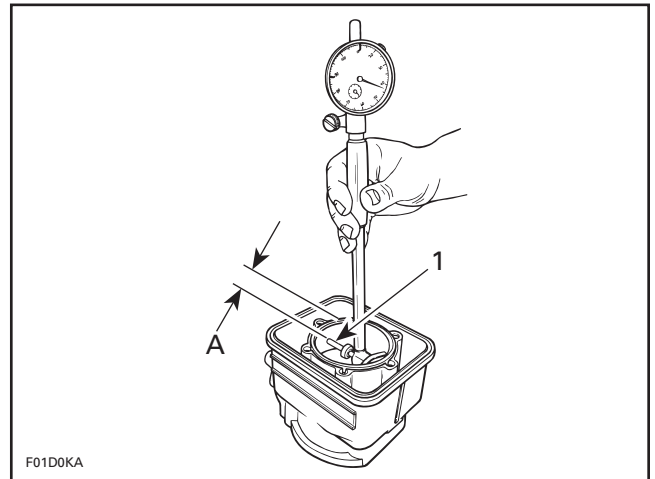

1. Measuring perpendicularly (90°) to piston pin axis
A. 16 mm (5/8 in)

Read the measurement on the cylinder bore gauge. The result is the exact piston/cylinder wall clearance. If clearance exceeds specified tolerance, replace cylinder.

NOTE: Make sure the cylinder bore gauge indicator is set exactly at the same position as with the micrometer, otherwise the reading will be false.

IMPORTANT: The total piston/cylinder clearance (actual cylinder diameter minus actual piston skirt diameter) should be within 0.30 mm (.012 in).

SECTION 04 - ENGINE PREPARATION

RING/PISTON GROOVE CLEARANCE

Using a feeler gauge check clearance between rectangular ring and groove. Replace piston if clearance exceeds specified tolerance. Refer to TECHNICAL DATA.

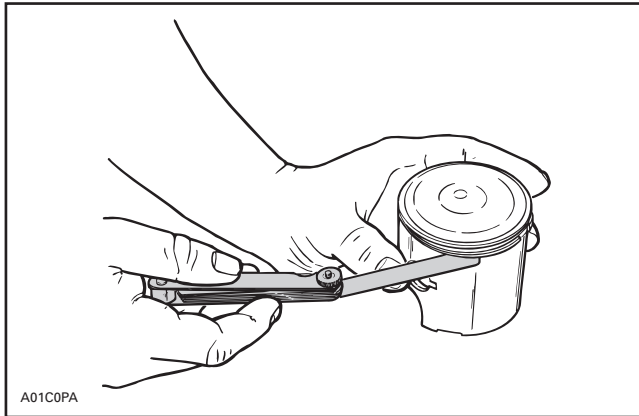

RING END GAP

Position ring half-way between transfer ports and intake port.

NOTE: In order to correctly position the ring in the cylinder, use piston as a pusher.

Using a feeler gauge, check ring end gap. Replace ring if gap exceeds specified tolerance. Refer to TECHNICAL DATA.

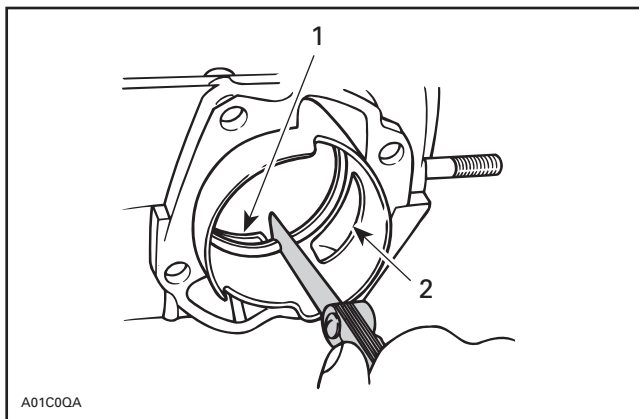

1. Transfer port
2. Intake port

CRANKSHAFT DEFLECTION

Crankshaft deflection is measured with a dial indicator.

Measuring (in crankcase)

First, check deflection with crankshaft in crankcase. If deflection exceeds the specified tolerance, recheck deflection using V-shaped blocks to determine the defective part(s). See below.

Measuring (on bench)

Once engine is disassembled, check crankshaft deflection on V-shaped blocks. If deflection exceeds the specified tolerance, it can be worn bearings or a bent crankshaft. Remove crankshaft bearings and check deflection again on V-shaped blocks to determine the defective part(s). See measurement A in following illustration.

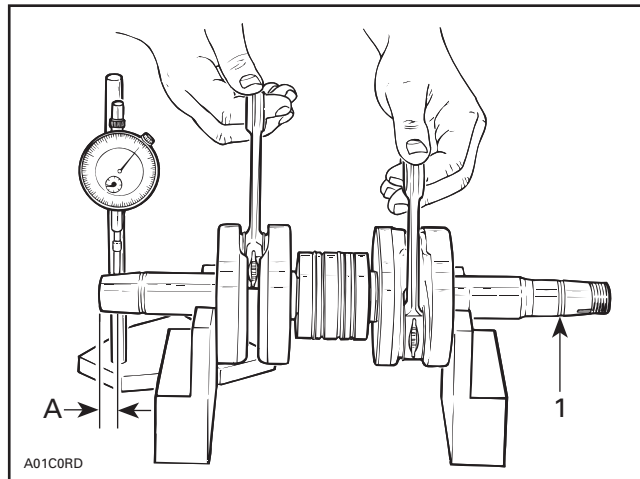

TYPICAL

1. Measure at mid point between the key and the first thread
- A. 3 mm (1/8 in)

Crankshaft Deflection on PTO Side

| ENGINE TYPE | MAXIMUM ON PTO SIDE mm (in) |
|-------------|--------------------------------|
| All | 0.06 (.0024) |

Crankshaft Deflection on MAG Side

| ENGINE TYPE | MAXIMUM ON MAG SIDE mm (in) |
|-------------|--------------------------------|
| All | 0.05 (.002) |

Crankshaft Deflection in Center of Crankshaft

| ENGINE TYPE | MAXIMUM IN CENTER OF CRANKSHAFT mm (in) |
|-------------|--|
| All | 0.08 (.0031) |

NOTE: Crankshaft deflection cannot be correctly measured between centers of a lathe.

If the deflection exceeds the specified tolerance, crankshaft should be repaired or replaced.

CONNECTING ROD BIG END AXIAL PLAY

| ENGINE TYPE | NEW PARTS MIN. - MAX. | WEAR LIMIT |
|-------------|------------------------------------|----------------------|
| All | 0.39 - 0.74 mm (.015 - .029 in) | 1.20 mm (.047 in) |

Using a feeler gauge, measure distance between thrust washer and crankshaft counterweight. If the distance exceeds specified tolerance, repair or replace the crankshaft.

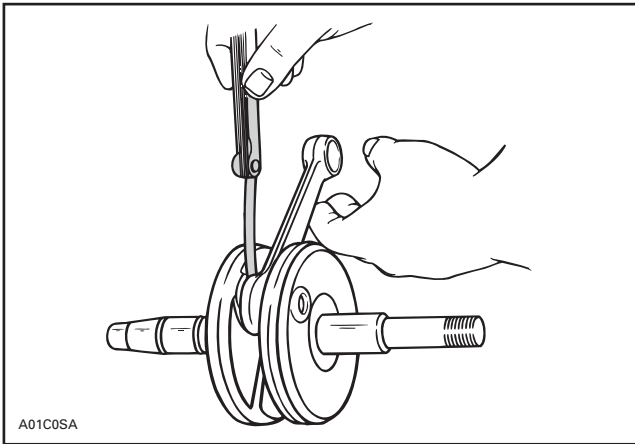

TYPICAL

CRANKSHAFT END-PLAY

All Engine Types

End-play is not adjustable but it should be between 0.10 - 0.30 mm (.004 - .012 in).

CHECKING CRANKSHAFT ALIGNMENT

Install a degree wheel (P/N 529 035 607) on crankshaft end.

Remove both spark plugs.

Install a TDC gauge (P/N 414 104 700) in spark plug hole on MAG side.

Bring MAG piston at top dead center.

Rotate degree wheel (not crankshaft) so that 360° mark aligns with center of crankcase. Scribe a mark on crankcase.

Remove TDC gauge and install it on center cylinder.

Bring PTO piston to top dead center. Degree wheel must rotate with crankshaft.

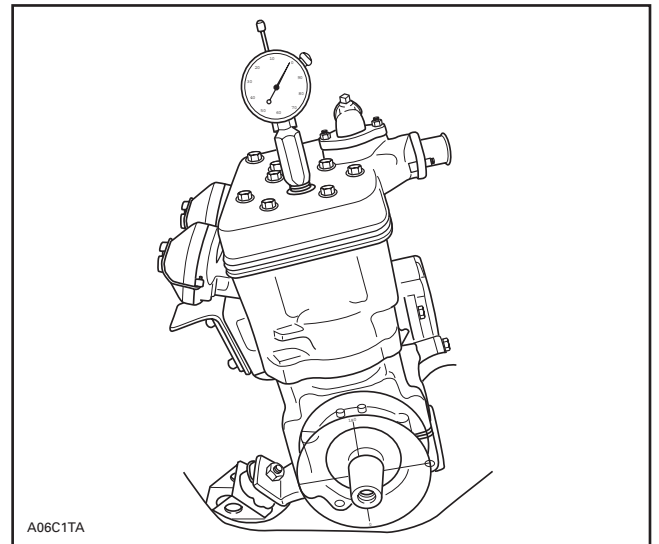

TYPICAL

Interval between cylinders must be 180° ± 0.5.

Any other reading indicates a misaligned (twisted) crankshaft.

NOTE: The following procedures can be done without removing the engine.

CDI means Capacitor Discharge Ignition System.

CLEANING

Clean all metal components in a non-ferrous metal cleaner.

CAUTION: Clean stator and magneto using only a clean cloth.

DISASSEMBLY

3, Magneto Flywheel

To gain access to magneto assembly, remove the following parts as needed on different engines:

- tuned pipe and muffler
- rewind starter
- starting pulley **no. 2**.

To remove magneto flywheel retaining nut **no. 1**:

- Use magneto puller ring (P/N 420 876 080). Former puller must be modified as shown.

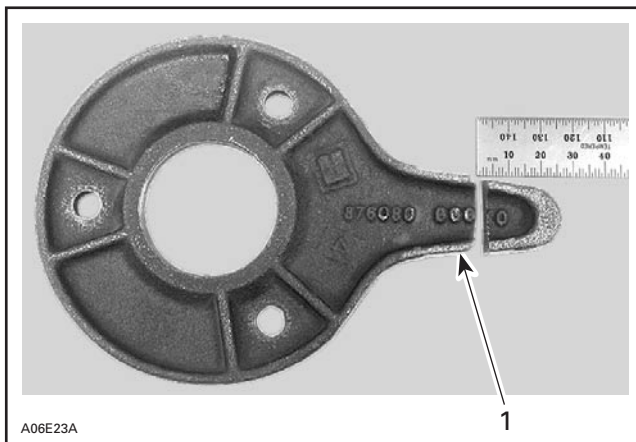

1. Cut by 25 mm (1 in)

- Install puller ring with its tab in magneto housing opening.

CAUTION: Use only M8 x 20 mm screws to bolt puller to magneto. When a counterweight **no. 7** is installed on magneto flywheel use M8 x 30 mm screws.

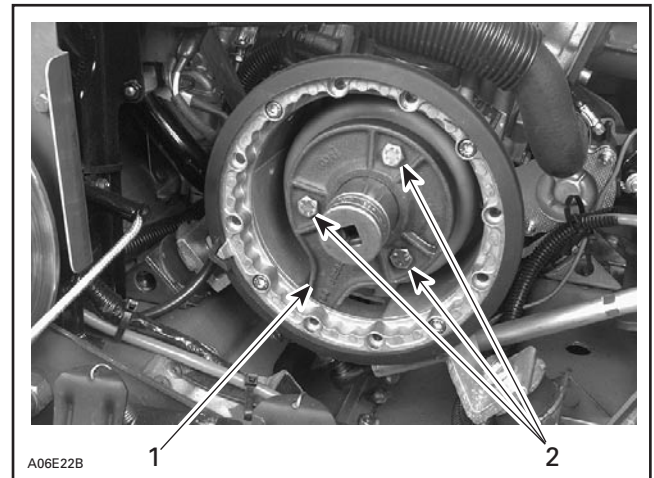

TYPICAL

1. Tab in magneto housing opening
2. M8 screws

- Remove magneto flywheel nut and lockwasher, using a 30 mm socket machined to 40 mm (1.580 in) outside diameter by 16 mm (5/8 in) long.

NOTE: To correctly remove a threadlocked fastener, first tap on the fastener to break threadlocker bond. This will avoid thread breakage.

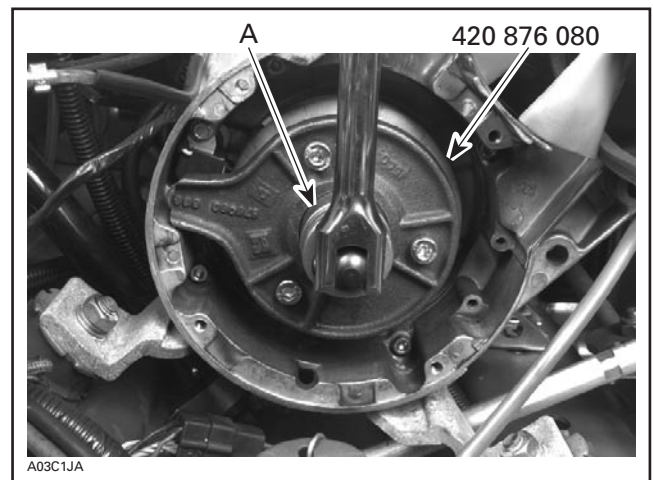

TYPICAL

- A. 30 mm socket

To remove magneto flywheel, install crankshaft protector (P/N 420 876 557) on crankshaft end. Screw puller (P/N 529 022 500) into puller ring.

- Tighten puller bolt and at the same time, tap on bolt head using a hammer to release magneto flywheel from its taper.

SECTION 04 - ENGINE PREPARATION

5, Trigger Coil

Magneto and stator **no. 6** must be removed before removing the trigger coil.

To replace the trigger coil **no. 5**:

- Disconnect trigger coil connector housing.
- Remove grommet from crankcase where trigger coil wire exits magneto housing.
- Remove retaining screws **no. 4**.
- Remove trigger coil and carefully pull wires.
- Install new trigger coil and other parts removed.

ASSEMBLY

6, Stator

Position stator so that its wire protectors are over crankcase recess.

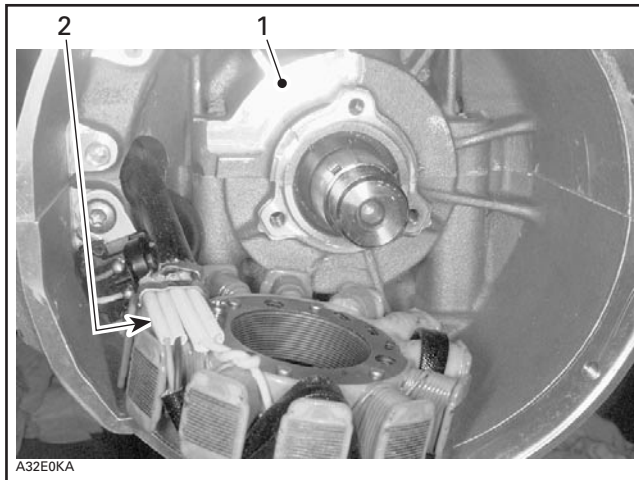

TYPICAL

1. Crankcase recess
2. Wire protectors

3, Magneto Flywheel

Clean crankshaft extension (taper) and apply Loctite 243 (blue) on taper, then position Woodruff key, flywheel and lock washer on crankshaft.

Clean nut threads and apply Loctite 243 (blue) then tighten nut to 125 N•m (92 lbf•ft).

At reassembly coat all electric connections except Deutsch housings (waterproof gray housing) with silicone dielectric grease (P/N 293 550 004) to prevent corrosion or moisture penetration.

CAUTION: Do not use silicone "sealant", this product will corrode contacts. Do not apply silicone dielectric grease on any Deutsch (gray) housing otherwise housing seal will be damaged.

Ignition Timing

Check as described in IGNITION TIMING.

OIL INJECTION SYSTEM

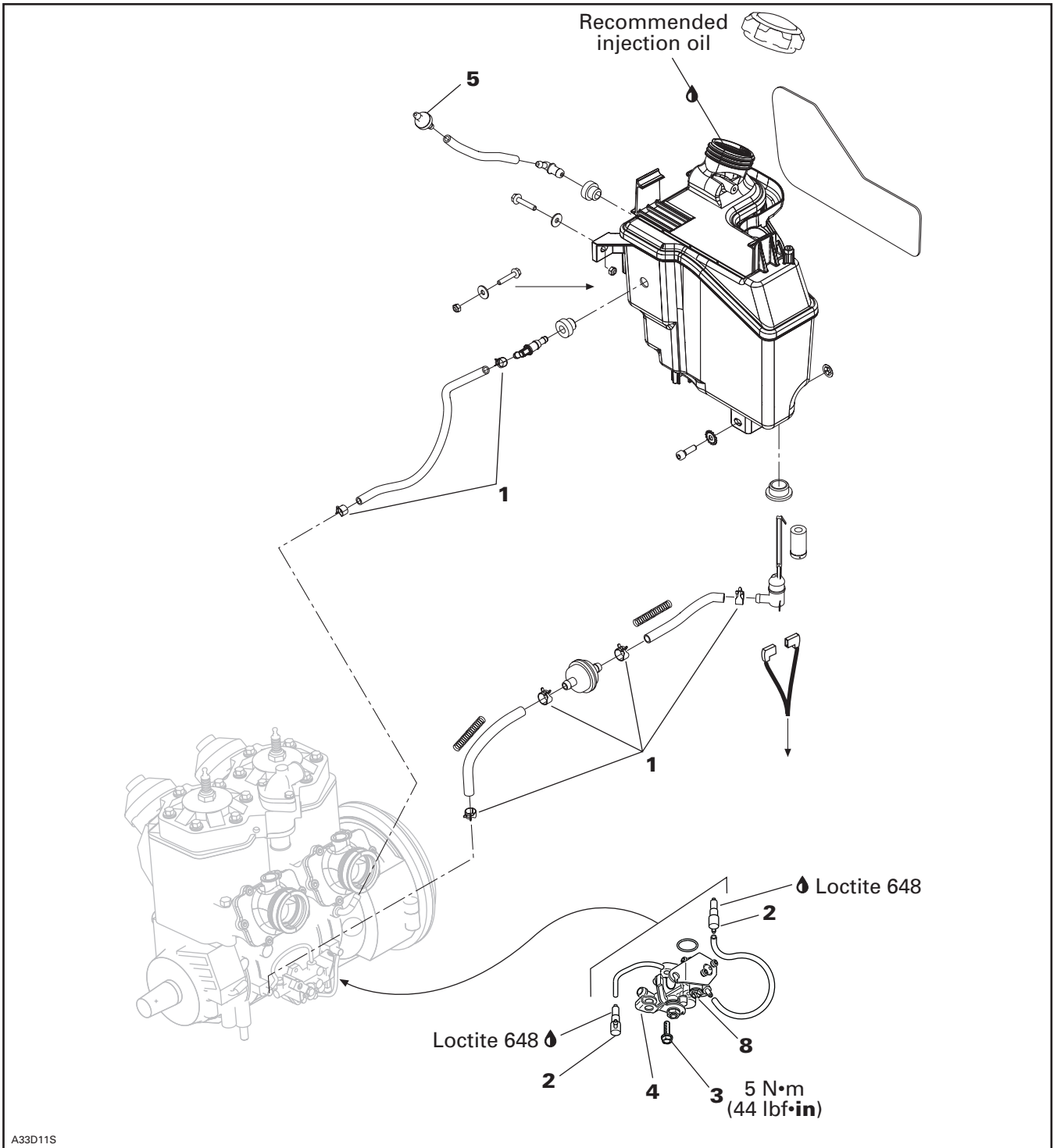

SECTION 04 - ENGINE PREPARATION

⚠ WARNING

Wipe off any oil spills. Oil is highly flammable.

OIL TYPE

Use recommended injection oil as per vehicle *Operator's Guide*.

OIL SYSTEM LEAK TEST

The following test will indicate any leak from oil reservoir to the banjo fitting(s).

Install special cap of leak testing kit (P/N 529 033 100) on oil reservoir and hose pincher (P/N 295 000 076) on oil reservoir check valve outlet hose.

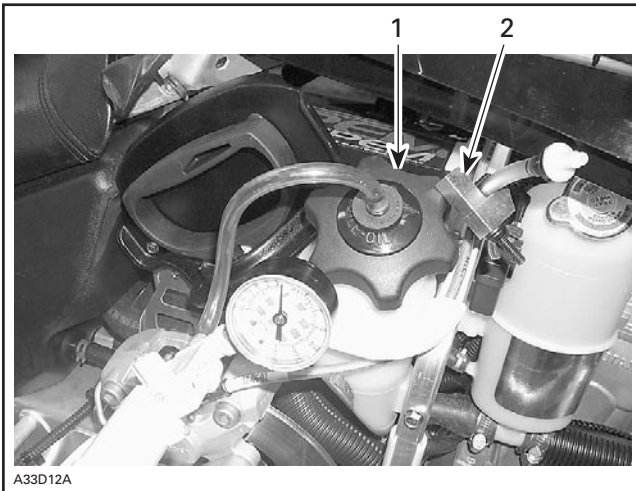

1. Special cap on reservoir
2. Hose pincher on outlet hose

Remove air silencer and carburetor to gain access to the oil pump hoses. Install hose pinchers (P/N 295 000 076) on outlet hoses.

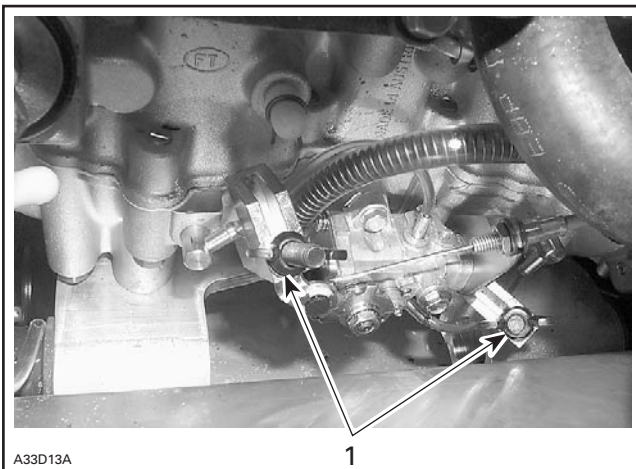

1. Hose pinchers on outlet hoses

Connect leak testing kit pump to special cap.

Pressurize oil system to 21 kPa (3 PSI). That pressure must not drop during 3 minutes.

If pressure drops, locate leak(s) and repair/replace leaking component(s).

After this leak test, proceed with pump shaft oil reservoir leak test. Refer to LEAK TEST AND ENGINE DIMENSION MEASUREMENT.

OIL PUMP IDENTIFICATION

4, Pump Lever

Different engines need different pumps. See identification on lever no. 4.

CAUTION: Always mount proper pump on engine.

| ENGINE TYPE | OIL PUMP IDENTIFICATION |
|-------------|-------------------------|
| 593 HO | 02 |
| 793 | 01 |

NOTE: The following procedures can be done without removing the engine from chassis.

CLEANING

Clean all metal components in a non-ferrous metal cleaner.

REMOVAL

NOTE: Some oil pump components are not available as single parts.

Remove screws no. 3 and if required uninstall the check valves no. 2.

INSTALLATION

1, Spring Clip

Always check for spring clips tightness.

2, Check Valve

Apply Loctite 648 (green) (P/N 413 711 400) on the outer diameter of the check valve (machined section). Take care that Loctite is ONLY in this area.

NOTE: Prior to coating it with Loctite, make sure check valve body is clean and dry. Clean from dirt or oil, if any, with Pulley flange cleaner (P/N 413 711 809).

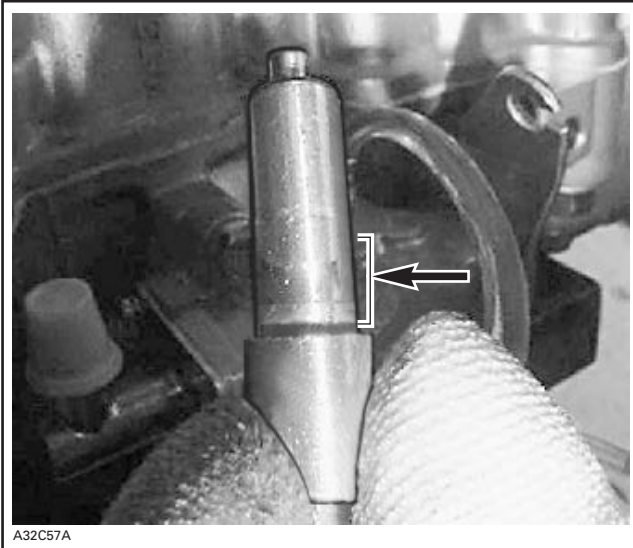

APPLY LOCTITE ON THIS AREA ONLY

Install the check valve in the correct position as described on next photos into the crankcase lower side.

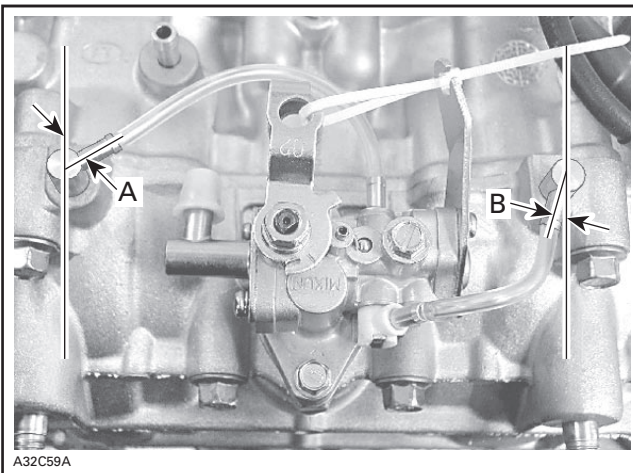

TYPICAL — POSITION FOR LIQUID COOLED ENGINES

- A. PTO side $45^\circ \pm 5^\circ$ from cylinder axis to the top
- B. MAG side $20^\circ \pm 5^\circ$ from cylinder axis to the bottom

Punch in the check valve carefully with a plastic hammer.

Clean the crankcase from surplus of Loctite 648 with a rag.

3, Screw

Torque to 5 N•m (44 lbf•in).

Cable plastic elbow must be fastened and fully inserted.

Make sure cable barrel is well seated in oil pump lever.

Secure barrel with plastic washer and circlip.

Install cable lock washer on left side of support.

Verify cable and oil pump lever operation.

ADJUSTMENT

CAUTION: Proper oil injection pump adjustment is very important. Any delay in the opening of the pump can result in serious engine damage.

Prior to adjusting the pump, make sure all carburetor adjustments are completed and engine is stopped.

Stretch the adjusting cable through a maximum force of 32 N•m (7.2 lbf•ft).

NOTE: It is better to have two persons to check the cable distance.

Check the visible distance of the stretched cable, while one person is stretching it and other checking the distance.

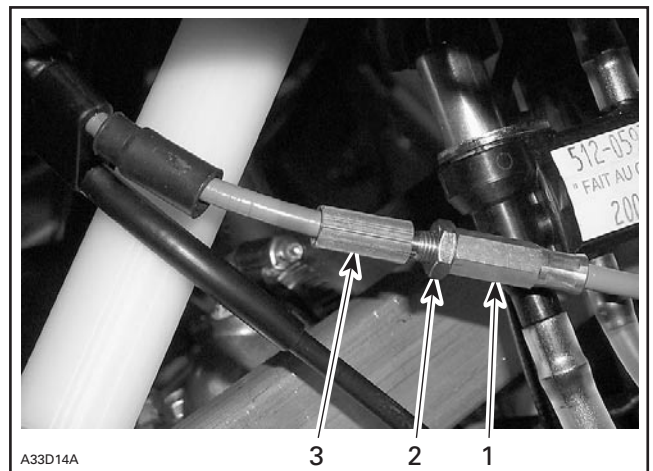

1. Adjusting cable
2. Lock nut
3. Adjusting screw

SECTION 04 - ENGINE PREPARATION

The visible stretched distance of the cable should be 18.0 ± 0.3 mm (0.708 ± 0.012 in).

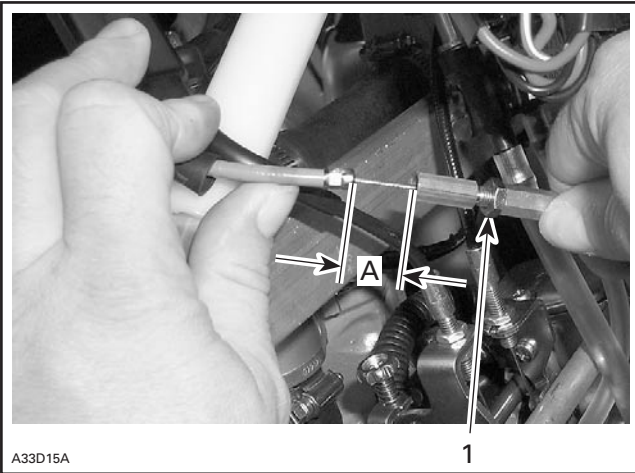

1. Lock nut

A. Visible distance: 18.0 ± 0.3 mm (0.708 ± 0.012 in)

If the visible distance is less or more than specified above, adjust the cable distance accordingly. To do so, loosen lock nut, turn adjusting screw in or out, retighten lock nut.

To Bleed Oil Lines

Bleed main oil line (between tank and pump) by loosening the bleeder screw **no. 8** until air has escaped from the line. Add injection oil as required.

Reinstall all parts.

Bleed the small oil line between pump and engine by running engine at idle while holding the pump lever in fully open position.

NOTE: Make a J hook out of mechanical wire to lift the lever.

WARNING

Ensure not to operate carburetor throttle mechanism. Secure the rear of the vehicle on a stand.

CHECKING OPERATION

Oil Pump

On Vehicle

NOTE: Main oil line must be full of oil. See bleeding procedure above.

Lift rear of vehicle and support with a mechanical stand. Unplug small oil lines from pump. Start engine and stop it as soon as it fires.

Check that oil in small oil lines has been sucked up (this will be indicated by a clear section of small oil lines). Repeat the procedure until this condition is attained.

Reconnect small oil lines, start engine and run at idle while holding the pump lever in fully open position. Oil columns must advance into small oil lines.

If not, remove pump assembly and check the pump gear and drive shaft (if applicable) for defects, replace as necessary. Test pump as describes below.

NOTE: Through normal use, oil level must not drop in small tubes. If oil drops, verify check valve operation in injection nozzle. Replace as necessary.

Test Bench

Connect a hose filled with injection oil to main line fitting. Insert other hose end in an injection oil container. Using a clockwise rotating drill rotate pump shaft. Oil must drip from outer fittings while holding lever in a fully open position. If not replace pump.

2, Check Valve

Check valve is a built in part of injection nozzle.

To verify this check valve, proceed the same as for checking pump operation on vehicle. First unplug oil line from check valve. After restarting the engine, check that a clear section in small oil line is present. Reconnect oil line.

Run engine at idle. Oil column must advance. If the check valve is faulty, oil column will go back and forth. Replace if so.

5, Oil Reservoir Check Valve

It allows air to get into the reservoir. To verify this one-way check valve, remove it along with the hose. Make sure that it holds pressure and that it does not let air go through.

While installing this check valve make sure that the black side is towards the reservoir.

LIQUID COOLING SYSTEM

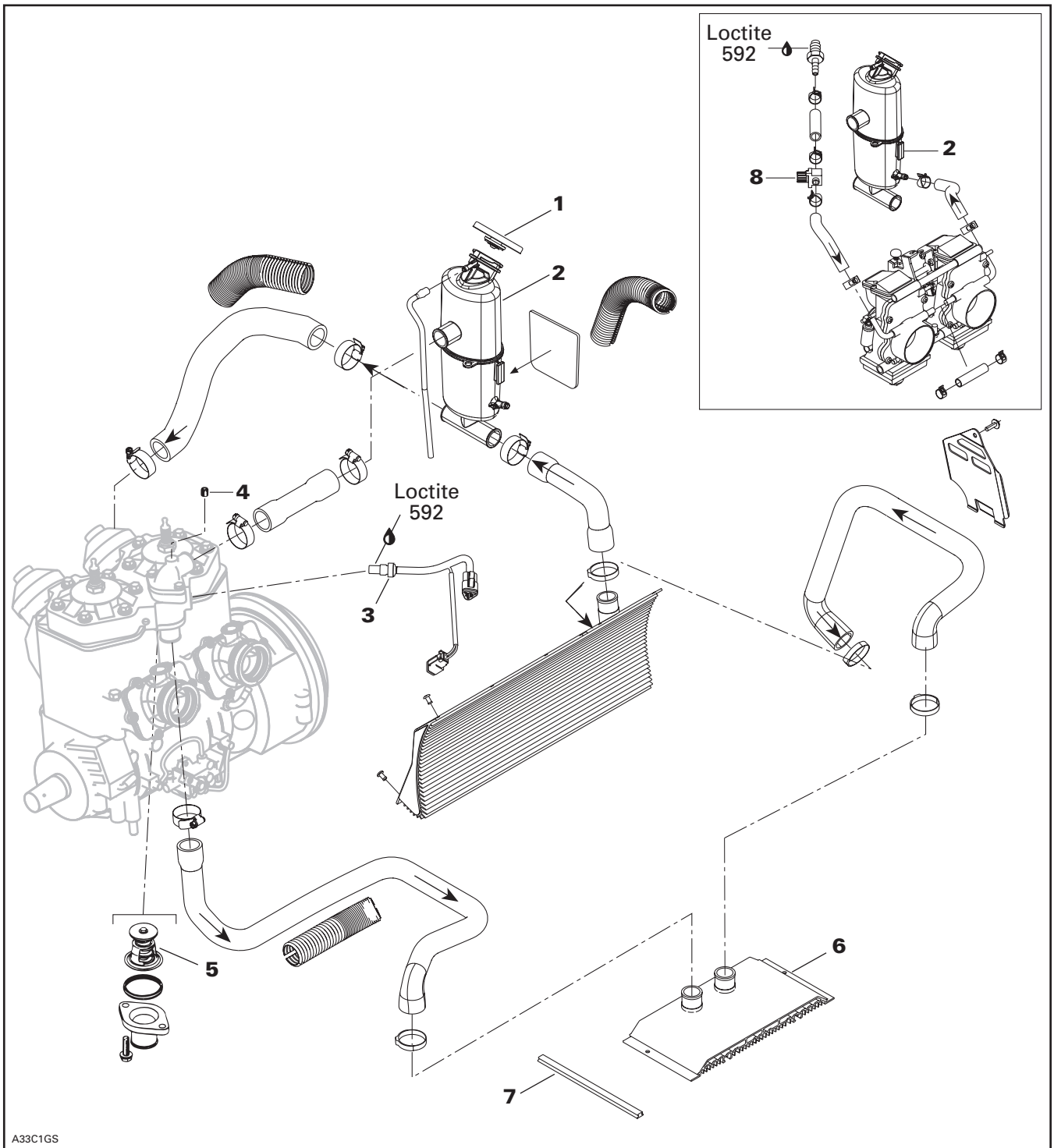

SECTION 04 - ENGINE PREPARATION

COOLING SYSTEM LEAK TEST

Install special radiator cap (P/N 529 021 400) included in engine leak tester kit (P/N 861 749 100) on coolant tank. Install hose pincher (P/N 295 000 076) on overflow hose. Using pump also included in kit pressurize all system through coolant reservoir to 100 kPa (15 PSI).

Check all hoses and cylinder/base for coolant leaks. Spray a soap/water solution and look for air bubbles.

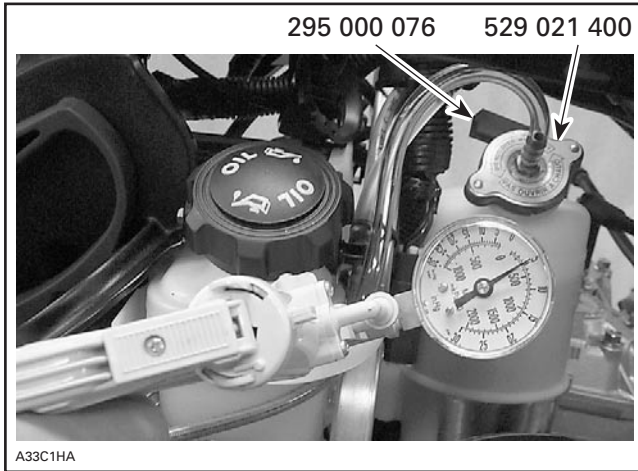

INSPECTION

Check general condition of hoses and clamp tightness.

DRAINING THE SYSTEM

⚠ WARNING

Never drain or refill the cooling system when engine is hot.

To drain the cooling system, siphon the coolant mixture from the coolant tank. Disconnect hose at water pump to drain coolant from engine.

When the coolant level is low enough, lift the rear of vehicle to drain the radiator.

DISASSEMBLY AND ASSEMBLY

3,4, Sender and Plug

Apply Loctite 592 (P/N 413 702 300) thread sealant on sender and plug to avoid leaks.

1, Pressure Cap

Check if the cap pressurizes the system. If not, install a new 90 kPa (13 PSI) cap (do not exceed this pressure).

6,7, Radiator and Radiator Protector

Insert radiator protector into radiator C-rail and crimp C-rail at rear end. Refer to FRAME for radiator removal.

5, Thermostat

To check thermostat, put in water and heat water. Thermostat should start to open when water temperature reaches the following degree. It will be almost fully open at 50°C (122°F).

| ENGINE | TEMPERATURE |
|--------|--------------|
| All | 42°C (108°F) |

Thermostat is a double action type.

- a. Its function is to give faster warm up of the engine by controlling a circuit; water pump — engine — coolant tank. This is done by bypassing the radiator circuit.

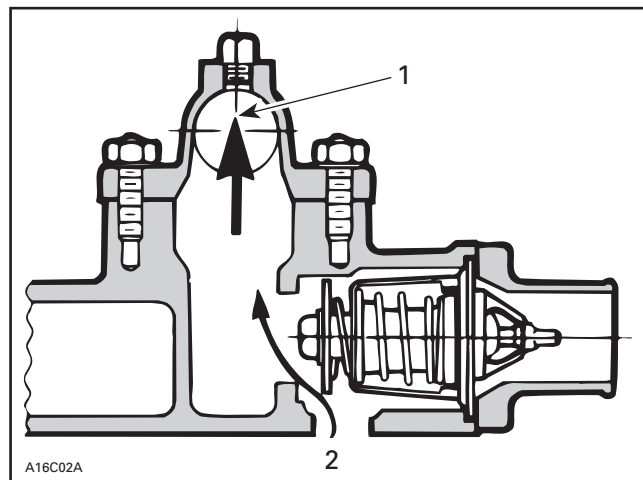

TYPICAL — CLOSED THERMOSTAT, COLD ENGINE

1. To reservoir
2. From cylinders

- b. When the liquid is warmed enough, the thermostat opens progressively the circuit, water pump — engine — radiators — coolant tank to keep the liquid at the desired temperature. (See the diagram of the exploded view).

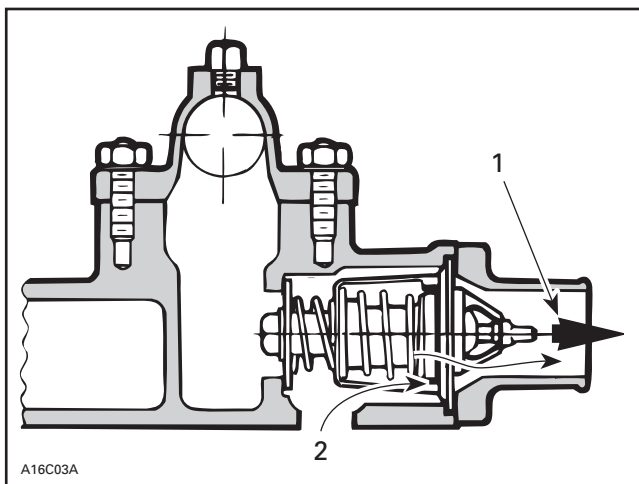

TYPICAL — OPEN THERMOSTAT, WARM ENGINE

1. To radiators
2. From cylinders

These 2 functions have the advantage of preventing a massive entry of cold water into the engine.

COOLING SYSTEM REFILLING PROCEDURE

CAUTION: To prevent rust formation or freezing condition, always replenish the system with recommended premixed coolant.

System Capacity

Refer to TECHNICAL DATA.

Refilling Procedure

IMPORTANT: USE THE 50/50 PREMIXED COOLANT - 37°C (- 35°F) (P/N 293 600 038).

Do not reinstall pressure cap.

Open heated carburetor valve no. 8.

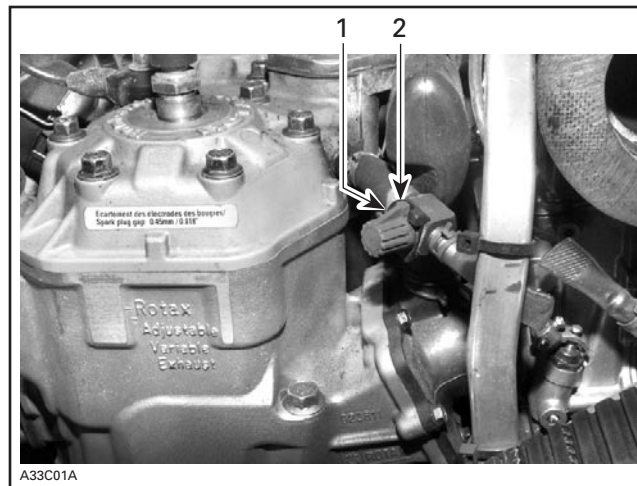

HEATED CARBURETOR VALVE

1. ON
2. OFF

With engine cold, refill coolant tank up to COLD LEVEL line. Start engine. Refill up to line while engine is idling until rear radiators are warm to the touch (about 4 to 5 minutes). Always monitor coolant level while filling tank to avoid emptying. Install pressure cap.

Lift rear of vehicle and support it safely.

Activate throttle lever 3 - 4 times to bring engine speed to 7000 RPM.

Apply the brake.

SECTION 04 - ENGINE PREPARATION

Lower vehicle back on ground and add coolant up to 15 mm (1/2 in) above the COLD LEVEL line.

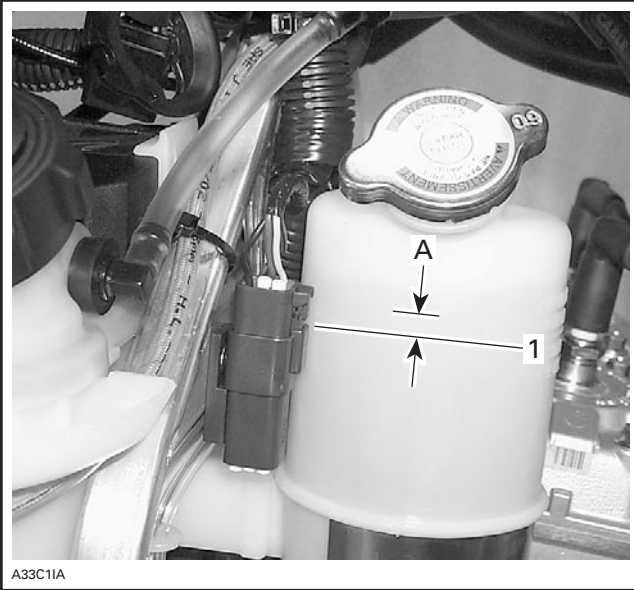

- 1. Cold level line
- A. 15 mm (1/2 in)

Lift front of vehicle of 60 cm (24 in) and support it safely. Let the vehicle idle for two minutes.

Put vehicle back on ground and add coolant up to 15 mm (1/2 in) over COLD LEVEL line.

When engine has completely cooled down, re-check coolant level in coolant tank and refill up to line if needed.

Check for coolant mixture freezing point. Specification is - 37°C (- 35°F). Adjust as necessary.

REWIND STARTER

Plastic Rewind Starter on REV Series Models

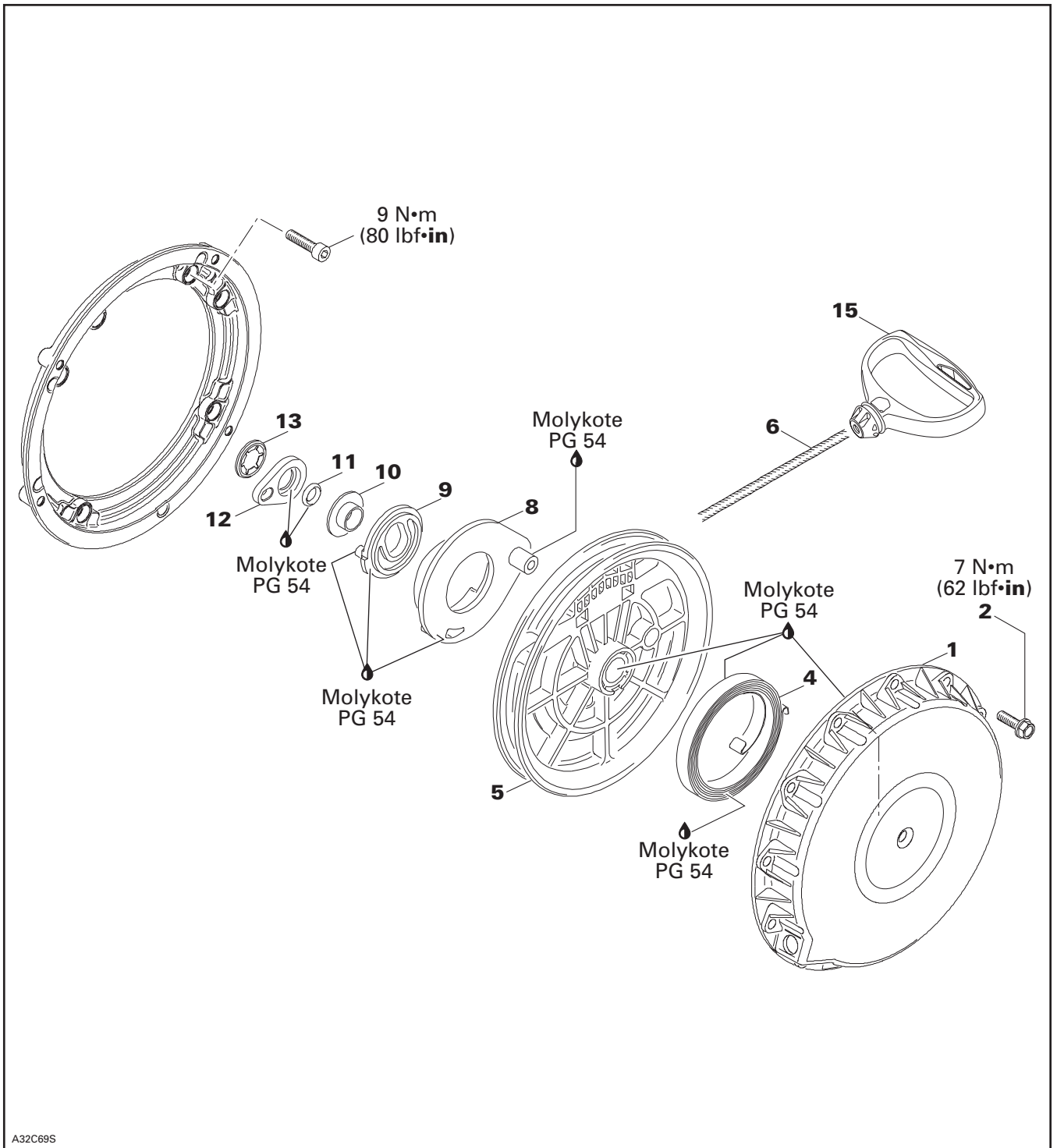

SECTION 04 - ENGINE PREPARATION

INSPECTION

NOTE: Due to dust accumulation, rewind starter must be periodically cleaned, inspected and lubricated.

CAUTION: It is of the utmost importance that the rewind starter spring be lubricated periodically using Molykote PG 54 (P/N 420 899 763). Otherwise, rewind starter component life will be shortened and/or rewind starter will not operate properly under very cold temperatures.

Check if rope no. 6 is fraying, replace if so.

When pulling starter grip, mechanism must engage within 30 cm (1 ft) of rope pulled. If not, disassemble rewind starter, clean and check for damaged plastic parts. Replace as required, lubricate, reassemble and recheck. Always replace O-ring no. 11 every time rewind starter is disassembled.

When releasing starter grip, it must return to its stopper and stay against it. If not, check for proper spring preload or damages. Readjust or replace as required.

When pulling starter grip 10 times in a row, it must return freely. If not, check for damaged parts or lack of lubrication. Replace parts or lubricate accordingly.

REMOVAL

Remove tuned pipes and muffler to gain access.

WARNING

Never remove exhaust components when engine is hot.

Using a small screwdriver, extract rope knot from starter grip no. 15. Cut rope close to knot. Tie a knot near starter.

Remove screws no. 2 securing rewind starter no. 1 to engine then remove rewind starter.

ROPE REPLACEMENT

Pull out rope. Hold rewind starter in a vise. Slide rope and untie the knot. Pull out the rope completely.

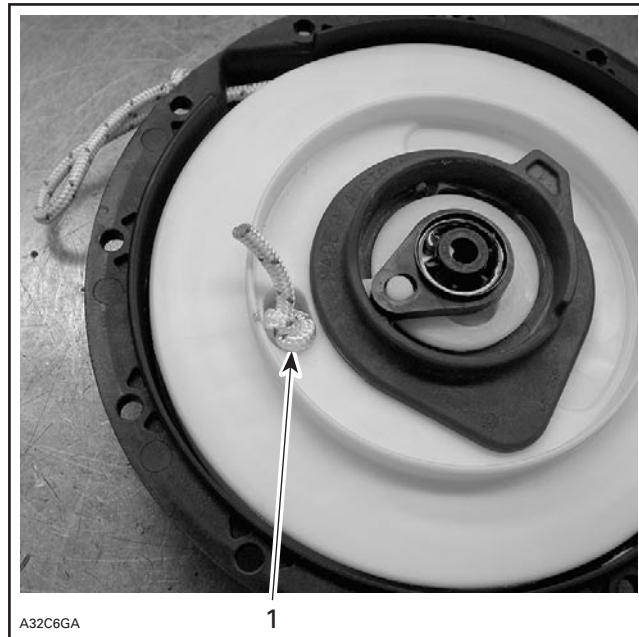

1. Knot to be untied.

NOTE: When rope is completely pulled out, spring preload is 4-1/2 turns.

DISASSEMBLY

Undo knot previously tied at removal. Let sheave get free to release spring preload.

Cut push nut no. 13 and discard. Remove locking element no. 12, O-ring no. 11, step collar no. 10, pawl lock no. 9 and pawl no. 8.

Remove sheave no. 5 from starter housing no. 1. Hold spring with a screwdriver.

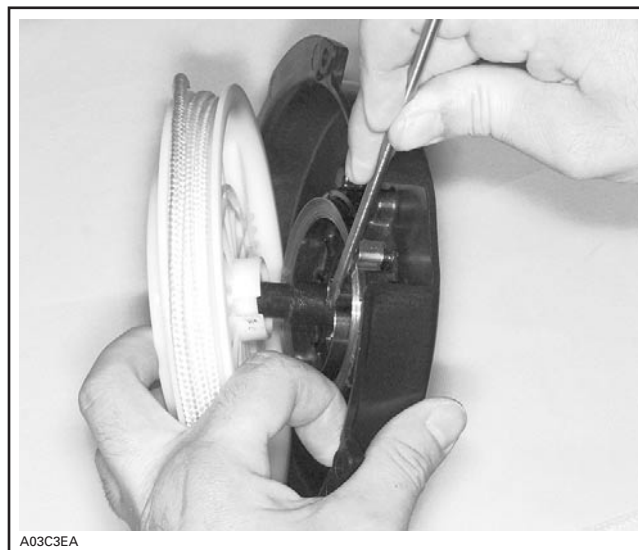

Pull out knot and then pull out rope no. 6.

ASSEMBLY

At assembly, position spring no. 4 outer end into spring guide notch then wind the spring counter-clockwise into guide.

⚠ WARNING
 Since the spring is tightly wound inside the guide it may fly out when rewind is handled. Always handle with care.



1. Outer end into guide notch

CAUTION: It is of the utmost importance that the rewind starter spring be lubricated periodically using Molykote PG 54 (P/N 420 899 763). Otherwise, rewind starter component life will be shortened and/or rewind starter will not operate properly under very cold temperatures.

Lubricate spring assembly and 1 cm (1/2 in) wide on bottom of housing with Molykote PG 54 (P/N 420 899 763).

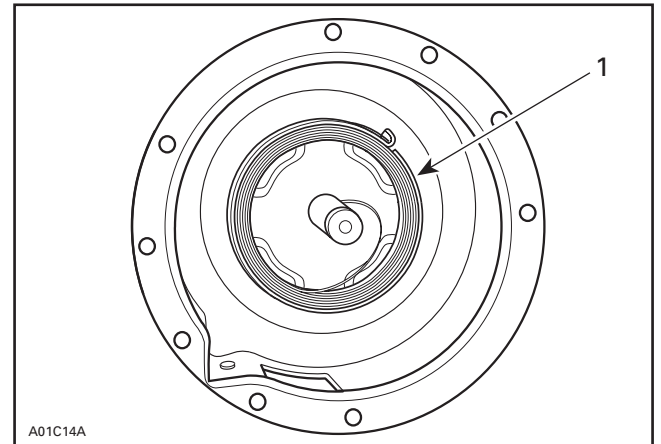

TYPICAL

1. Molykote PG 54 inside spring guide

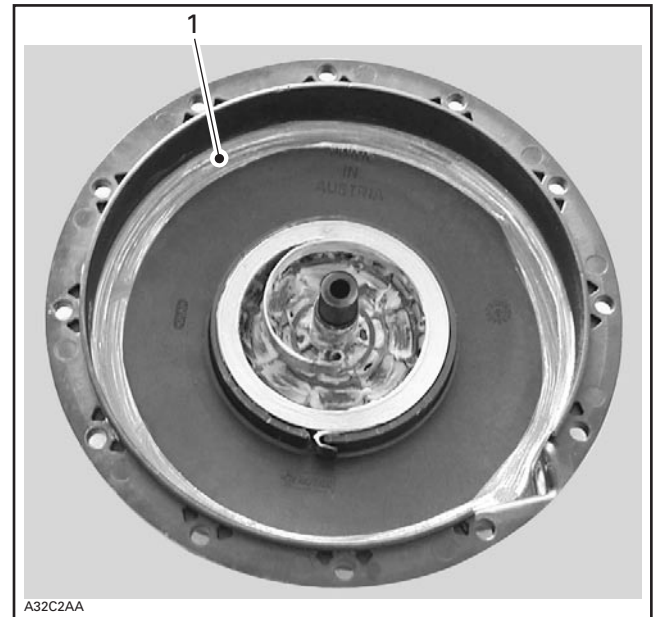

1. Molykote PG 54 applied 1 cm (1/2 in) wide on bottom of housing

CAUTION: The use of standard multi-purpose grease could result in rewind starter malfunction.

SECTION 04 - ENGINE PREPARATION

To install rope no. 6, insert rope into sheave no. 5 orifice and lock it by making a knot, leaving behind a free portion of about 25 mm in length. Fuse rope end with a lit match and insert it into sheave.

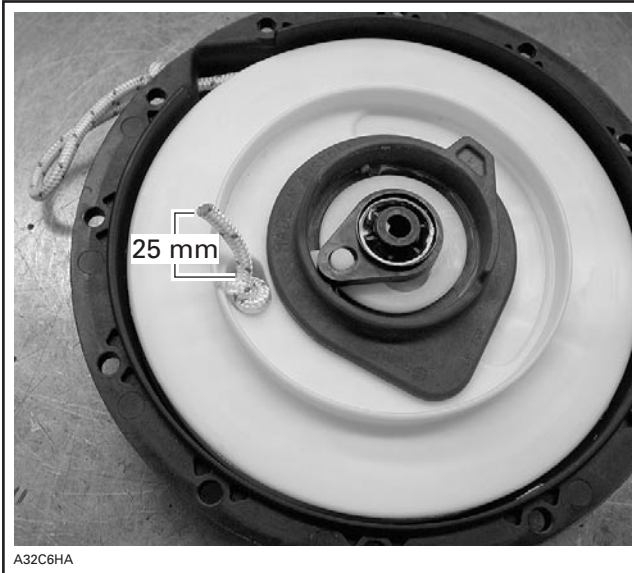

FREE PORTION



FREE PORTION INSERTED INTO SHEAVE

Lubricate housing post with silicone compound grease. Install sheave.

To adjust rope tension:

Wind rope on sheave and place rope sheave into starter housing making sure that the sheave hub notch engages in the rewind spring hook.

Rotate the sheave counterclockwise until rope end is accessible through rope exit hole. This will give 1/2 turn of preload.

Pull the rope out of the starter housing and temporarily make a knot to hold it.

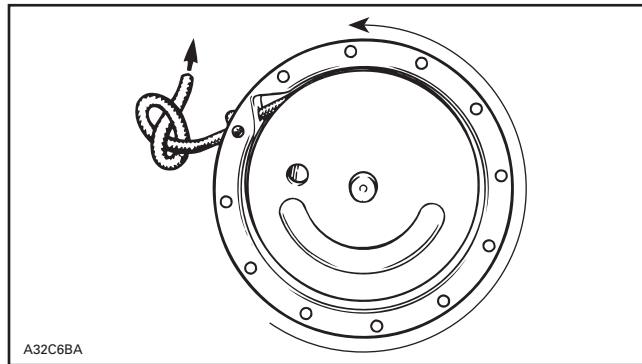

TYPICAL

Lubricate pawl no. 8 with Molykote PG 54 (P/N 420 899 763) then install over rope sheave.



Lubricate pawl lock **no. 9** with Molykote PG 54 (P/N 420 899 763). Install over pawl.



Install step collar **no. 10** with its sleeve first. Lubricate a new O-ring **no. 11** and locking element **no. 9** with Molykote PG 54 (P/N 420 899 763). Install over pawl lock.

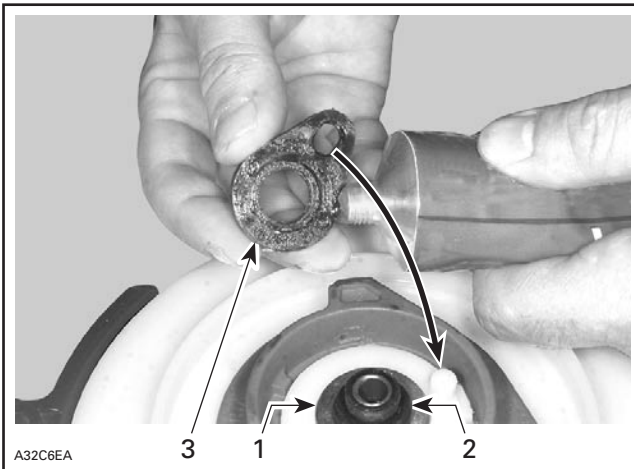

1. Step collar
2. O-ring
3. Locking element

Install a new push nut **no. 13**.

INSTALLATION

Fuse rope end with a lit match.

Thread starter rope **no. 6** through rope guide when applicable.

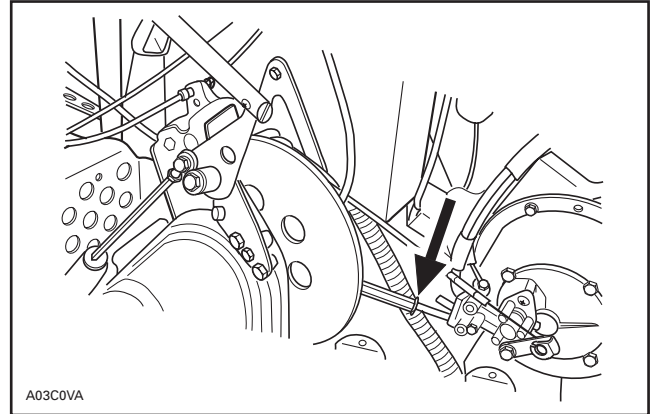

TYPICAL

Reinstall rewind starter assembly on engine.

Pass rope through starter grip **no. 15** and tie a knot in the rope end. Insert rope end down and pull the starter grip over the knot.

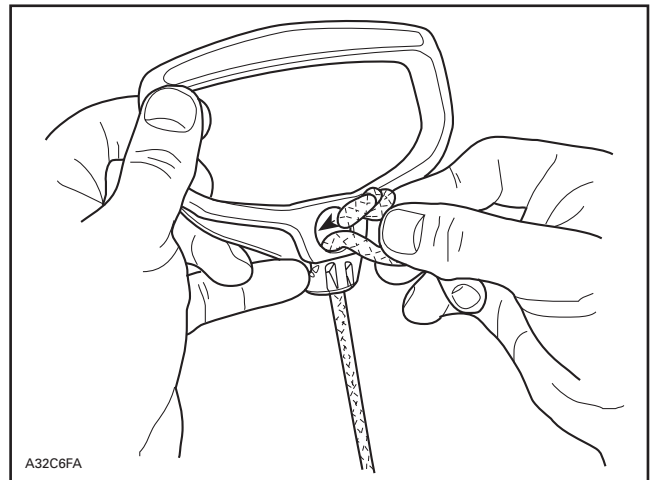

TYPICAL

TABLE OF CONTENTS

BASIC FUNCTIONS OF THE SYSTEM 05-3

EFFECTS OF THE DRIVE PULLEY LEVER ARM, ROLLER AND ROLLER PIN WEIGHT 05-4

EFFECTS OF THE RAMP PROFILE ON THE SHIFT FORCE 05-7

RAMP CHARACTERISTICS 05-9

EFFECTS OF THE DRIVE PULLEY SPRING 05-10

TRA III..... 05-13

VSA..... 05-13

TUNING COMPONENTS..... 05-13

TRA III..... 05-14

DRIVE PULLEY 05-14

GENERAL 05-15

REMOVAL..... 05-15

DISASSEMBLY..... 05-15

CLEANING 05-17

INSPECTION 05-17

ASSEMBLY..... 05-17

INSTALLATION 05-21

DRIVE PULLEY ADJUSTMENT..... 05-21

KIT P/N 486 400 003 TRA III WEIGHT SET-UP FOR PIN..... 05-23

TRA SPRINGS CHART..... 05-28

EFFECTS OF THE DRIVEN PULLEY SPRING 05-30

HPV 27 VSA CLUTCH SPRINGS 05-31

EFFECTS OF THE DRIVEN PULLEY CAM..... 05-32

DRIVEN CLUTCH CAMS 05-33

FORMULA VSA 05-35

REMOVAL..... 05-36

DISASSEMBLY..... 05-36

CLEANING 05-36

INSPECTION 05-37

ASSEMBLY..... 05-37

INSTALLATION 05-37

ADJUSTMENT 05-37

HPV27 VSA 05-39

REMOVAL..... 05-40

DISASSEMBLY..... 05-40

CLEANING 05-40

INSPECTION 05-40

ASSEMBLY..... 05-41

INSTALLATION 05-41

ADJUSTMENT 05-41

SPRINGS 05-44

ADJUSTING BELT DEFLECTION ON THE TEAM ROLLER SECONDARY..... 05-44

BELT REMOVAL ON TEAM ROLLER SECONDARY 05-45

MEASURING BELT DEFLECTION..... 05-45

TEAM SECONDARY CLUTCH MAINTENANCE/ADJUSTMENT..... 05-46

SECTION 05 - DRIVE SYSTEM

| | |
|--|--------------|
| INSTALLATION | 05-47 |
| TROUBLESHOOTING | 05-47 |
| GENERAL | 05-51 |
| GENERAL PROCEDURE | 05-51 |
| PULLEY ALIGNMENT AND DISTANCE SPECIFICATIONS CHART | 05-52 |
| APPLICATION CHART | 05-55 |
| DRIVE BELTS | 05-55 |
| INSPECTION | 05-55 |
| CHECKING NEUTRAL FUNCTION | 05-55 |
| ROTATION DIRECTION | 05-55 |
| DRIVE BELT HEIGHT MEASUREMENT AND ADJUSTMENT | 05-56 |
| DRIVE BELT DEFLECTION MEASUREMENT (reference only) | 05-58 |
| CHAINCASE GEARING | 05-59 |
| MX Z X 440 GEAR RATIO VS SPEED | 05-61 |
| CHAINCASE GEARS AND CHAINS | 05-62 |
| HYDRAULIC BRAKE | 05-66 |
| TRANSMISSION CALIBRATION PROCEDURE | 05-63 |
| TRANSMISSION TUNING TEST SHEET | 05-64 |
| RACERS LOG | 05-65 |
| BRAKE FLUID TYPE | 05-67 |
| CALIPER | 05-67 |
| BRAKE PADS REPLACEMENT | 05-67 |
| REMOVAL | 05-68 |
| DISASSEMBLY | 05-69 |
| CLEANING | 05-69 |
| INSPECTION | 05-69 |
| INSTALLATION | 05-69 |
| ADJUSTMENT | 05-70 |
| BLEEDING | 05-70 |
| REMOVAL AND DISASSEMBLY | 05-72 |
| INSPECTION | 05-72 |
| GEAR RATIO MODIFICATION | 05-72 |
| INSTALLATION AND ASSEMBLY | 05-73 |
| DRIVE CHAIN ADJUSTMENT | 05-73 |
| ADJUSTMENT | 05-74 |
| REMOVAL | 05-76 |
| ASSEMBLY | 05-77 |
| LUBRICATION | 05-78 |
| ADJUSTMENT | 05-78 |
| TRACK TYPE APPLICATION | 05-79 |
| GENERAL | 05-79 |
| INSPECTION | 05-79 |
| REMOVAL | 05-79 |
| INSTALLATION | 05-79 |
| ADJUSTMENT | 05-79 |

BASIC FUNCTIONS OF THE SYSTEM

The TRA Clutch

We call it a clutch but that set of pulleys is a lot more than simply a clutch. Once the system reaches its low ratio speed, the clutch function ends and the pulleys become a completely automatic transmission searching for the highest gear ratio that can be pulled at the engine's given output. In the case of our TRA clutch, the pulleys will begin shifting from a 3.8:1 ratio in low gear to a .8:1 overdrive ratio in high gear. That is a lot of ratio change. A typical six-speed motorcycle gearbox, for instance, will change from a 2.38:1 ratio in low gear to a .96:1 overdrive ratio in high gear.

The ratio changing is done by opening and closing a drive and driven pulley and forcing a fixed length drive belt to turn around different diameters on each pulley. The force used to **close** the engine or drive pulley is centrifugal force. It is the job of the ramps, rollers and lever arms to convert and control the centrifugal force.

Each engine will produce its maximum horsepower at a particular RPM. Power will decrease at engine speeds on either side of the peak power RPM. The usable width of the power band will dictate where the clutch must be calibrated to keep the engine performing at its peak. In the power curve the mildly-tuned engine has its peak horsepower of 64 at 5800 RPM and has a usable power band width of 1500 RPM. The race tuned engine produces its peak of 92 horsepower at 9300 RPM, but only has a usable power band width of 400 RPM. The race engine will have to have a much more accurately calibrated clutch to be able to keep the engine running within a 400 RPM range compared to the 1500 RPM wide range of the mildly-tuned engine.

The goal of clutch calibration is to keep the engine, at full throttle at its peak horsepower RPM and, at the same time, to select the highest possible gear ratio as dictated by the load on the drive axle. The speed diagram illustrates what the goal of good clutch calibration is.

In the speed diagram, the inclined line labelled low ratio indicates the vehicle speed at each RPM when locked into the 3.8:1, low gear ratio. At 8000 RPM, the vehicle speed would be just under 20 MPH if held in this ratio. The high ratio line compares vehicle speed with engine RPM when the transmission is locked into the .8 :1 high gear. At this ratio, the vehicle speed would be just under 80 MPH when the engine is turning 8000 RPM. In calibrating the clutches, the objective will be to maintain as horizontal a line as possible between the low ratio and high ratio lines. This transition line or shift speed must be as close as possible to the engine peak horsepower RPM.

Engagement speed of the clutch is always set as **low** as possible to avoid track slippage and to prolong drive belt life. The clutch must be engaged at an RPM that is high enough, however, that the engine will be producing enough horsepower to overcome drag and allow acceleration without bogging. In the speed diagram, the acceleration period between 0 and about 20 MPH illustrates the actual clutching period of the transmission. During this time the rollers in the clutch are on the initial angles of the clutch ramps and the drive belt is actually slipping in the engine pulley as engine and vehicle speeds increase to about 9000 RPM at 25 MPH. The transmission then begins upshifting to the high ratio at a constant engine RPM. Engine speed should not increase above the calibration RPM until the high ratio is achieved. If the engine RPM exceeds the calibration RPM once the high gear position is achieved, it is an indication that the chaincase gearing is too low. If clutch calibration is accurate, engine speed should never vary more than 50 RPM from the peak power RPM. This is the optimum shift curve.

The following section will discuss each of the tunable components of both the drive and driven pulleys and provides some insight and data necessary for tuning the system.

SECTION 05 - DRIVE SYSTEM

POWER CURVES MILDLY TUNED VS. RACE TUNED

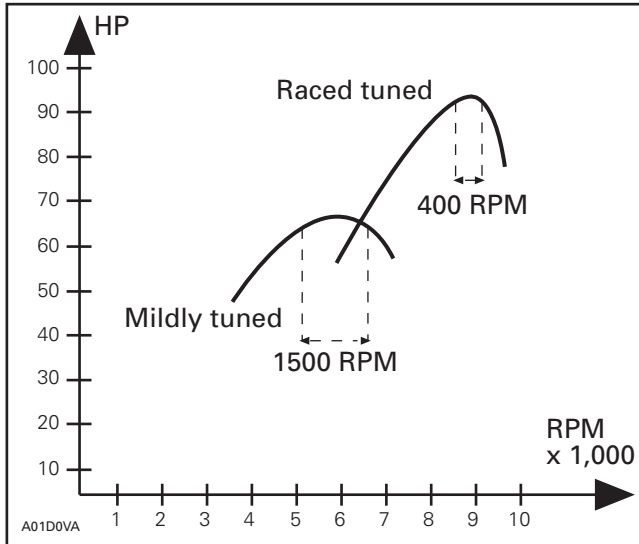

SPEED DIAGRAM ENGINE SPEED VS. VEHICLE SPEED

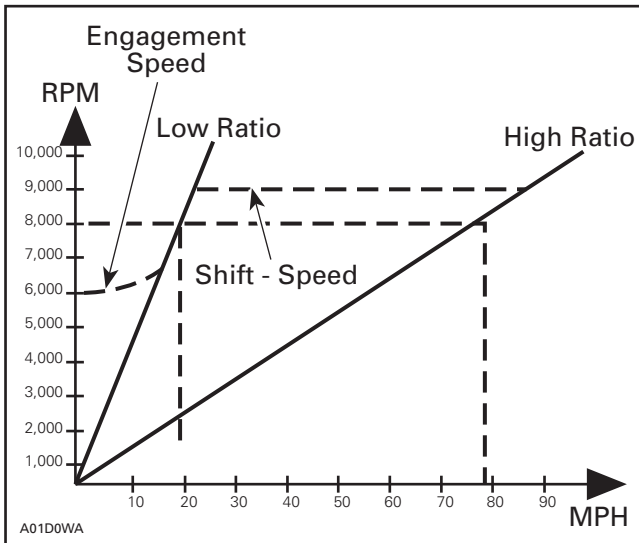

EFFECTS OF THE DRIVE PULLEY LEVER ARM, ROLLER AND ROLLER PIN WEIGHT

As you have seen in the formula defining centrifugal force, the force increases directly with the weight of the components involved. If you want to increase the centrifugal force, therefore, the shift force, it is a simple matter to increase the weight of the pressure levers. If the overall RPM is too high, a heavier lever arm or roller pin could be installed. The opposite would apply if the RPM is too low.

The major factor controlling centrifugal force is engine RPM. Because the force increases with the square of this speed, you can quickly have too much force if heavy weights are used on a clutch fitted to a high RPM engine. Because of this relationship, you will find heavy weights used on low RPM, high torque engine types and much lighter weights used on the high RPM engines.

The effect of the weights will always be greater at high RPM, and at higher ratios. This is true because of the relation of the force to the square of the engine speed. Also the radius from the axis of rotation to the center of mass of the counterweights increases as the roller is allowed to move down the ramps. As this radius increases, the centrifugal force increases directly. Addition of weight will affect engagement speed very little compared to the effect the weight will have at mid-range to top speed.

Minor changes in weight are accomplished by using various weight roller pins. The effects of adding weight are illustrated in the following illustration. The three curves show the engine RPM increasing from engagement speed (4000 RPM) to about 6500 RPM which is achieved at about 30 MPH. From this point on, if calibration is accurate, there is no change in engine RPM as the vehicle speed increases. From the machine standing at rest to about 30 MPH, belt slippage and other factors are involved that allow the engine to get on the power.

Curve **A** shows a clutch set up with three 10-gram type roller pins. This amount of weight will govern the engine to 7200 RPM and allow engagement of the clutch at 4000 RPM.

Curve **B** illustrates the effect of exchanging the three 10-gram pins for three 14-gram roller pins. The additional weight has virtually no effect on engagement speed but pulls the peak RPM of the engine down to 6800 RPM.

Curve **C** illustrates the effect of using three 16-gram roller pins. Again, the additional weight has little effect on the engagement RPM but further reduces the top RPM to 6400 RPM. For example, by adding 2 grams per arm for a total weight increase of 6 grams on an engine turning at around 7500 RPM, there would be about a 200 RPM decrease in full power engine speed — approximately the same effect as going 1 clicker position lower.

On a high RPM race engine it may only take a 1 gram, increase per arm to see a 200 RPM decrease in peak operating RPM.

SECTION 05 - DRIVE SYSTEM

Drive Clutch Roller Pins

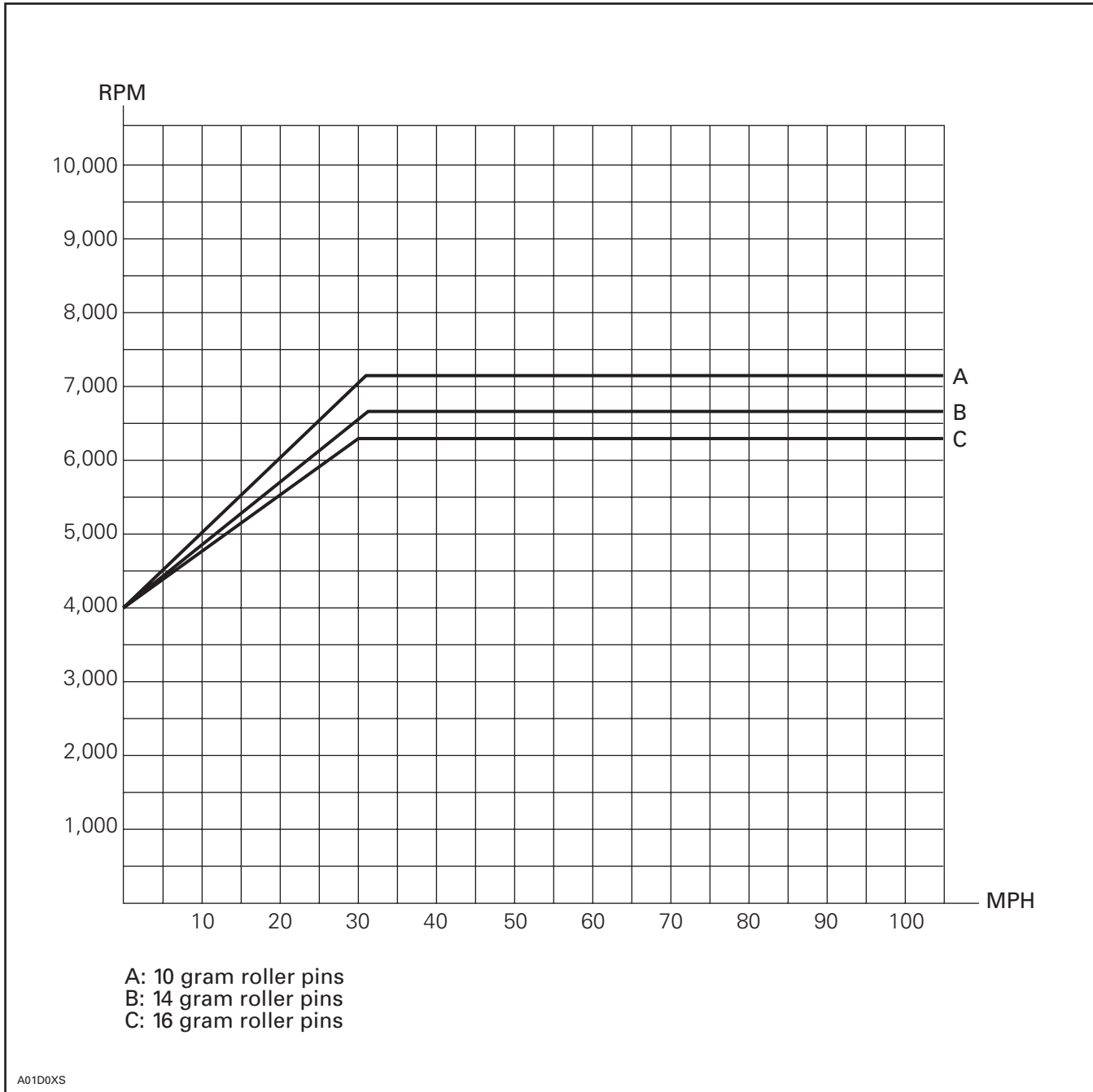

The weight of the lever arms will have a similar effect on the shift RPM.

By adding or removing weight to or from the arms, we can fine tune the shift RPM to the engine power peak.

If you increase the horsepower of the engine at the same RPM, you would normally add more weight to keep the engine pulling as hard as possible and not over rev.

If you lighten the weights on the arms, you will be increasing the shifting RPM. However, your vehicle will not **pull** as hard, since less centrifugal force is being generated.

EFFECTS OF THE RAMP PROFILE ON THE SHIFT FORCE

The shift force is the component or part of the centrifugal force that is used to actually move the sliding half of the drive pulley. This force is applied to the sliding half at the three lever arm pivot points (following illustration item 49). The ramp profiles are used to control the size of this shift force.

As the clutch rotates around the center line of the crankshaft, the axis of rotation, centrifugal forces begin building and act on the center of mass of the lever arm, roller combination trying to pull the lever away from the axis of rotation. The center of mass of the lever arm assembly is the point where all the centrifugal force acts (following illustration item 70).

The ramp provides an angled surface for the roller to push against and the angle of the ramp at the point of contact with the roller determines how much of the centrifugal force is translated into axial force. The axial force pushes the sliding half in and the remainder of the centrifugal force is unused and absorbed by the integrity of the sliding half. A steeper ramp angle gives less shift force, while a smaller angle gives more shift force.

As you can see in following illustration, the angle of the ramp varies constantly from start to finish. The angle varies to achieve the proper axial force to transmit a given amount of torque through the drive belt at each diameter of the pulley.

As discussed before, the centrifugal force generated by the lever arm assembly increases at higher ratios. This is why the ramp profile is much steeper at the high ratio end. This reduces the shift force in order to maintain the correct load on the belt.

Remember, it is the angle of the ramp at the point of roller contact that will help determine the shift force at any given ratio. Think of the ramp profile as a hill that the roller must climb. A small angle or hill can be overcome easily thus providing a faster shift out to a higher ratio which will lower the engine RPM. If the hill is steeper (the ramp angle is larger) the roller will not be able to climb it as quickly thus staying in a lower ratio longer which will keep the engine RPM higher.

Note that at engagement and very low ratios, many ramp angles actually go downhill. These are generally used on engines with good low RPM power. Engines with narrower power bands and less low RPM power will usually have a flatter angle at engagement and low speed. A ramp with a small bump at engagement is used to raise the engagement RPM. Again, the steeper the "hill" the roller must overcome, the higher the RPM will be before the clutch shifts out. If the spring selection cannot give the desired engagement RPM, then use a ramp with a bump or grind a notch at the point where the roller sits at engagement. Of course if the shift profile was good at higher ratios, then you would want to use a ramp with only changes at the low speed area.

Also, a thicker or taller ramp will provide higher RPM than a thinner ramp with the same profile because the lever arm assembly is tucked in further by the taller ramp.

The TRA clutch allows you to fine tune the ramp profile by using the adjusters provided. The adjusters are cams which allow you to raise and lower the outer end of the ramp through six different positions. Moving the ramp end toward the lever arm makes the ramp angles steeper, thereby raising engine speed and slowing the upshift. As the ramp is adjusted away from the lever arm, the engine speed is lowered and the upshift is faster.

SECTION 05 - DRIVE SYSTEM

In clinical condition such as on a dynamometer, moving the adjusters up will result in a 150 to 200 RPM increase with each position change. Lowering the adjuster positions will result in a decrease of 150 to 200 RPM with each number. On the snowmobile, however, depending on the operating conditions, a change of one adjuster position may not show up on the tachometer, but the shift speed of the pulley will have changed. The upshift or downshift, depending on which way you moved the adjusters, will be faster and your acceleration rate and top speed will have changed. When using the TRA adjusters, the acceleration rate and speed should be checked as well as the engine RPM.

RAMP CHARACTERISTICS

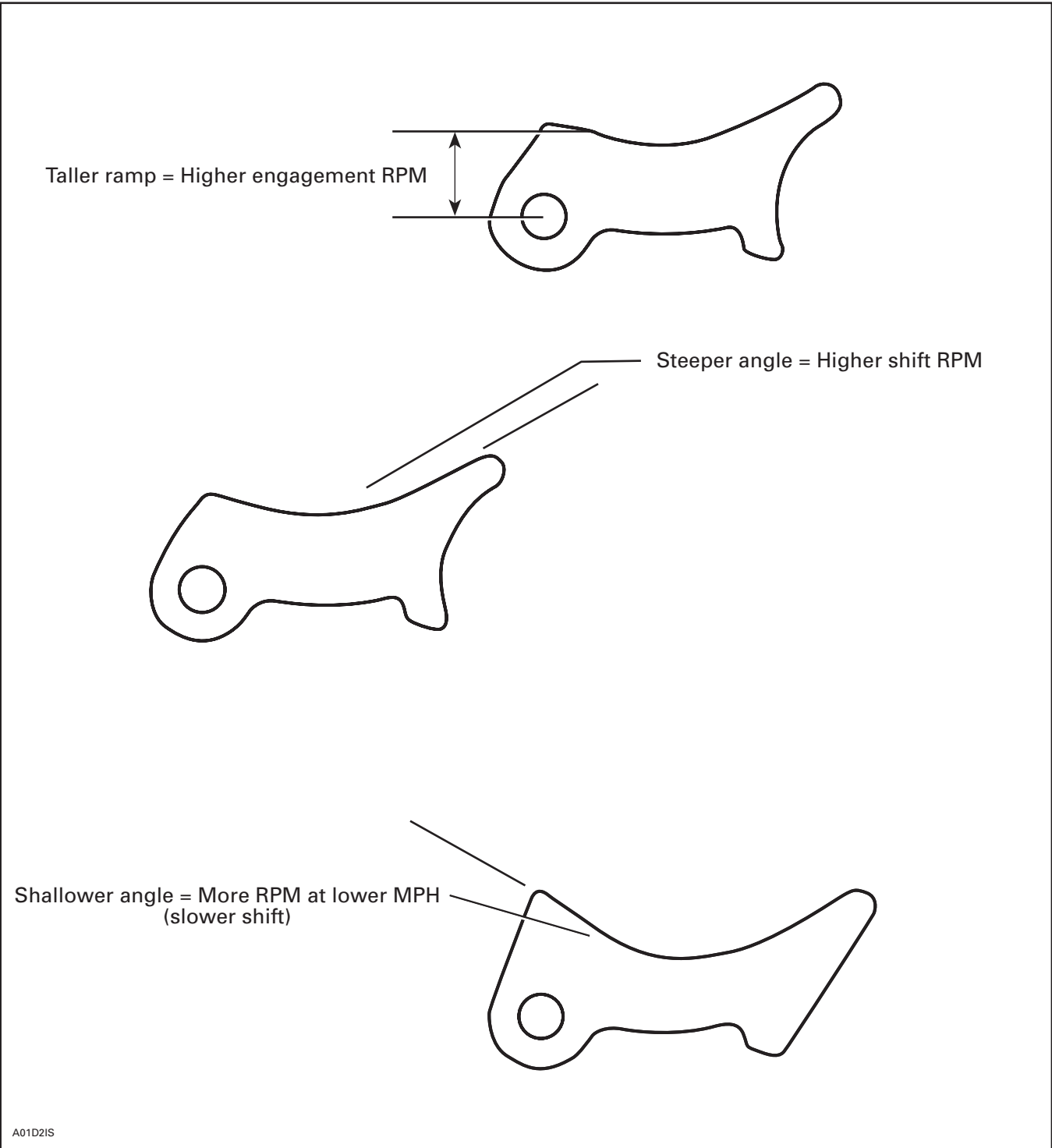

SECTION 05 - DRIVE SYSTEM

EFFECTS OF THE DRIVE PULLEY SPRING

The purpose of the clutch release spring is to return the sliding half of the engine pulley and the associated moving parts to the disengaged or neutral position at low engine RPM. The spring tension is calibrated to work with the pressure levers and ramp angles to allow clutch engagement at the desired RPM. As the engine speed increases, centrifugal forces increase and eventually overcome the tension of the release spring and allow the pulley halves to contact the drive belt. As engine speed decreases, centrifugal forces decrease and the clutch spring returns the sliding half toward the neutral position.

As the clutch shifts out to a higher ratio, the spring balances the shift forces being generated by the levers and ramps.

The spring tension will affect the entire shifting sequence of the engine pulley. The effect that it has will depend upon the construction of the spring. Three things must be known about the spring to be able to predict its effect in the clutch: 1. The spring free length; 2. The spring pressure when compressed to 74 mm (2.9 in); 3. The spring pressure when compressed to 41 mm (1.6 in). These three factors are listed on the accompanying sheet.

The spring free length will give you an idea of the condition of the spring. If the spring has lost more than 6.35 mm (1/4 in) of its listed free length, the spring is fatigued or has taken too great a set. The spring should be replaced. The free length of the spring is its overall length when resting freely on a table top.

In the TRA clutch, the installed length of the clutch release spring is 74 mm (2.9 in). This is the length of the spring when the pulley is in its neutral position. The pressure that the spring applies at this length is the factor that controls the engagement speed (all other things kept constant). When the engine pulley is in its highest ratio position, the spring will be compressed to 41 mm (1.6 in). The pressure the spring applies at this length will determine the RPM required to reach high gear; again, with all other tunable factors kept constant.

As you look through the spring chart, you will see that springs are available with equal pressures at 74 mm (2.9 in), but very different pressures at 41 mm (1.6 in). You will also note varying pressures at 74 mm (2.9 in) and equal pressures at 41 mm (1.6 in). Simply by working with the spring charts, one can easily see how the shift speed (the speed with which the change from one gear ratio to the next is made) and the engagement speed can be altered.

As the pressure of the spring when 74 mm (2.9 in) long is increased, the clutch engagement speed will increase. As the spring rate is increased, the engine will be required to turn more RPM to achieve a given gear ratio. Again, these facts hold true when all other tunable components are kept constant.

On chart 1, spring **A** has a pressure of 311 N (70 lb) at 74 mm (2.9 in) and a pressure of 1157 N (260 lb) when compressed to 41 mm (1.6 in). With no other changes made in the clutch, spring **B** was installed. The spring has a preload of 712 N (160 lb) at 74 mm (2.9 in) and a pressure of 1201 N (270 lb) at 41 mm (1.6 in). As the chart indicated, the engagement RPM increased 1000 RPM while the shift curve from 30 MPH up remained relatively unchanged.

Chart 2 illustrates the effect of keeping the spring preload pressure at 74 mm (2.9 in) constant and increasing the pressure at the 41 mm (1.6 in) length. In this example, spring **A** has a pressure of 311 N (70 lb) at 74 mm (2.9 in) and a pressure of 756 N (170 lb) at 41 mm (1.6 in). Spring **B** also has a pressure of 311 N (70 lb) at 74 mm (2.9 in) but increases to 1157 N (260 lb) at 41 mm (1.6 in). The projected effect of this spring change is shown on chart 2. Since the preload pressure at 74 mm (2.9 in) is equal for springs **A** and **B**, the engagement speed is not affected. At 95 MPH, however, there is a loss of RPM with spring **A** in place.

**Drive Clutch Spring
Effect at Engagement**

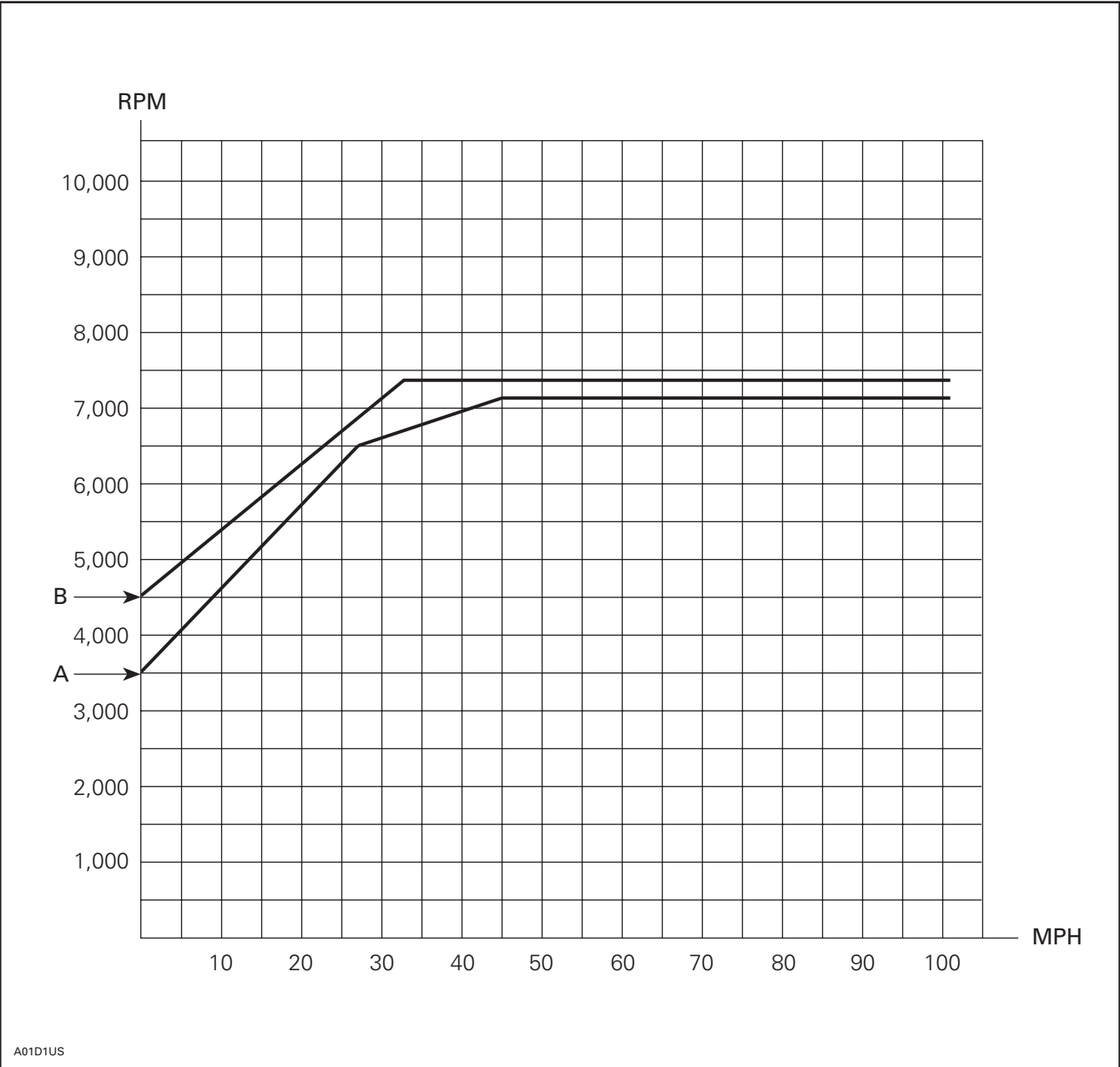

A01D1US

| | LOAD AT 74 mm (2.9 in) | LOAD AT 41 mm (1.6 in) |
|---|---------------------------|---------------------------|
| A | 311 N (70 lb) | 1157 N (260 lb) |
| B | 712 N (160 lb) | 1201 N (270 lb) |

SECTION 05 - DRIVE SYSTEM

Drive Clutch Spring

Effect at Top Speed

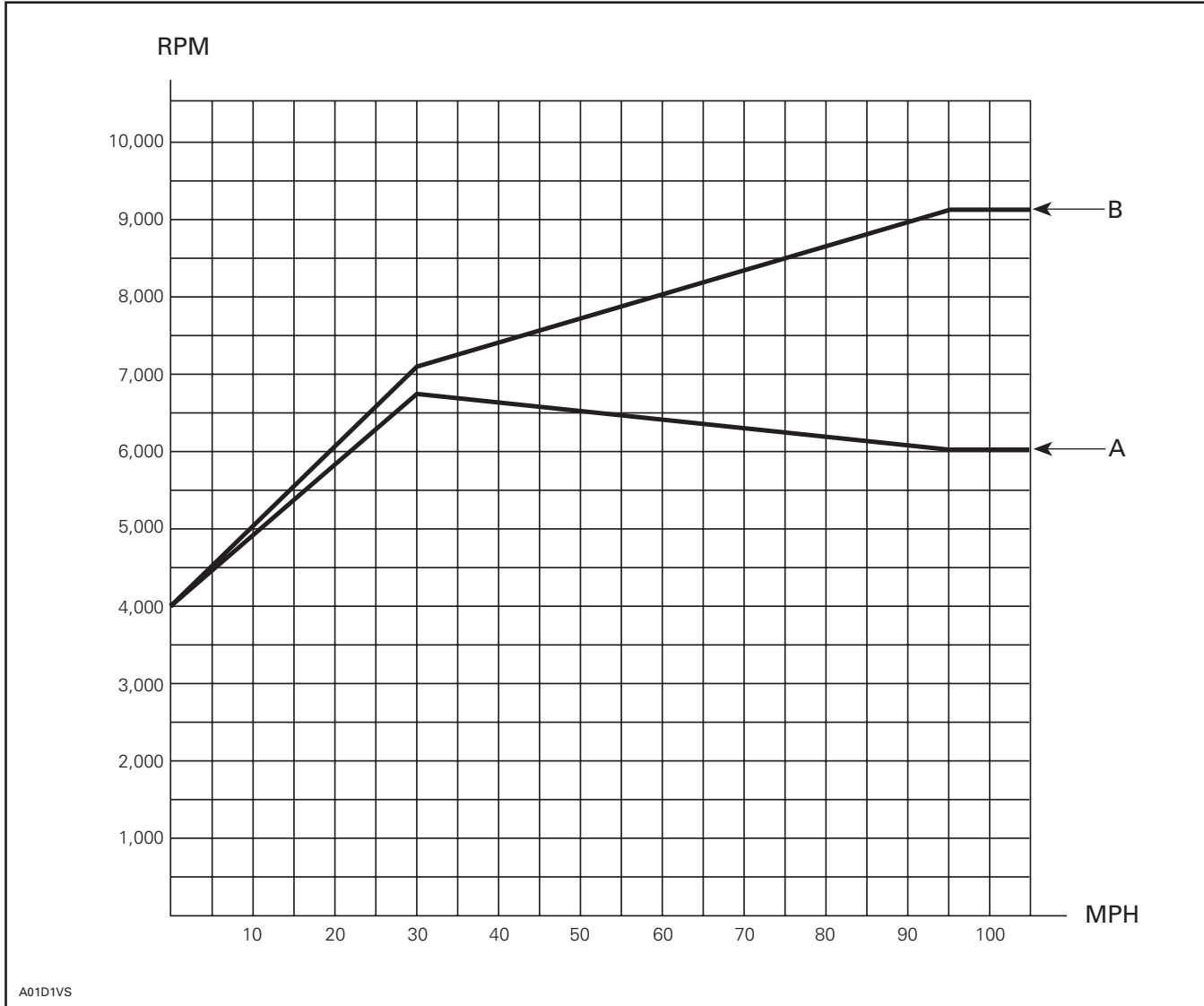

| | LOAD AT 74 mm (2.9 in) | LOAD AT 41 mm (1.6 in) |
|---|---------------------------|---------------------------|
| A | 311 N (70 lb) | 756 N (170 lb) |
| B | 311 N (70 lb) | 1157 N (260 lb) |

TRA III

Some 2004 models come equipped with a TRA III style drive clutch. They include most models with the 600 and 800 cc engines. This style of clutch is the “next” generation of engineering development from Ski-Doo and will certainly be used in more models as years go on.

Visual comparisons between the TRA and TRA III styles may appear slight, but in fact, there are many differences, and when you are working with it, you need to be aware of the differences.

VSA

The TRA III has Variable Sheeve Angle (VSA). The machined angle of both sheeves varies from 12 degrees at the bottom to 14 degrees at the top. This provides better efficiency through out the entire range of shift. With the improved efficiency, belt life is also extended. The TRA III clutch must be matched with a VSA type driven clutch and belt to achieve maximum performance.

TUNING COMPONENTS

As mentioned earlier, few tuning components can be interchanged between the TRA and TRA III clutches. Springs, rollers and some pin weights can be interchanged. Short pins can be used but not the heavy long ones, as they will cause interference. Ramps and arms cannot be interchanged. At this time, only one type of arm is available through Ski-Doo, and that is the production aluminum. However, several ramps have been developed to allow you to tune your sled. Below is a list of ramps available and how they compare to a TRA ramp.

| TRA III | P/N | TRA EQUIVALENT |
|---------|-------------|----------------------------|
| 410 | 417 222 596 | 299 |
| 411 | 417 222 514 | 299 |
| 412 | 417 222 515 | 293 |
| 414 | 417 222 546 | 300 |
| 415 | 417 222 548 | 300 less load at beginning |
| 417 | 417 222 552 | 293 less load at beginning |
| 419 | 417 222 557 | 414 with engagement notch |

SECTION 05 - DRIVE SYSTEM

DRIVE PULLEY

TRA III

All REV Series Models

NOTE: This is a lubrication free drive pulley. Always refer to appropriate parts catalog for replacement part. Most parts of TRA III are not interchangeable with those of the TRA.

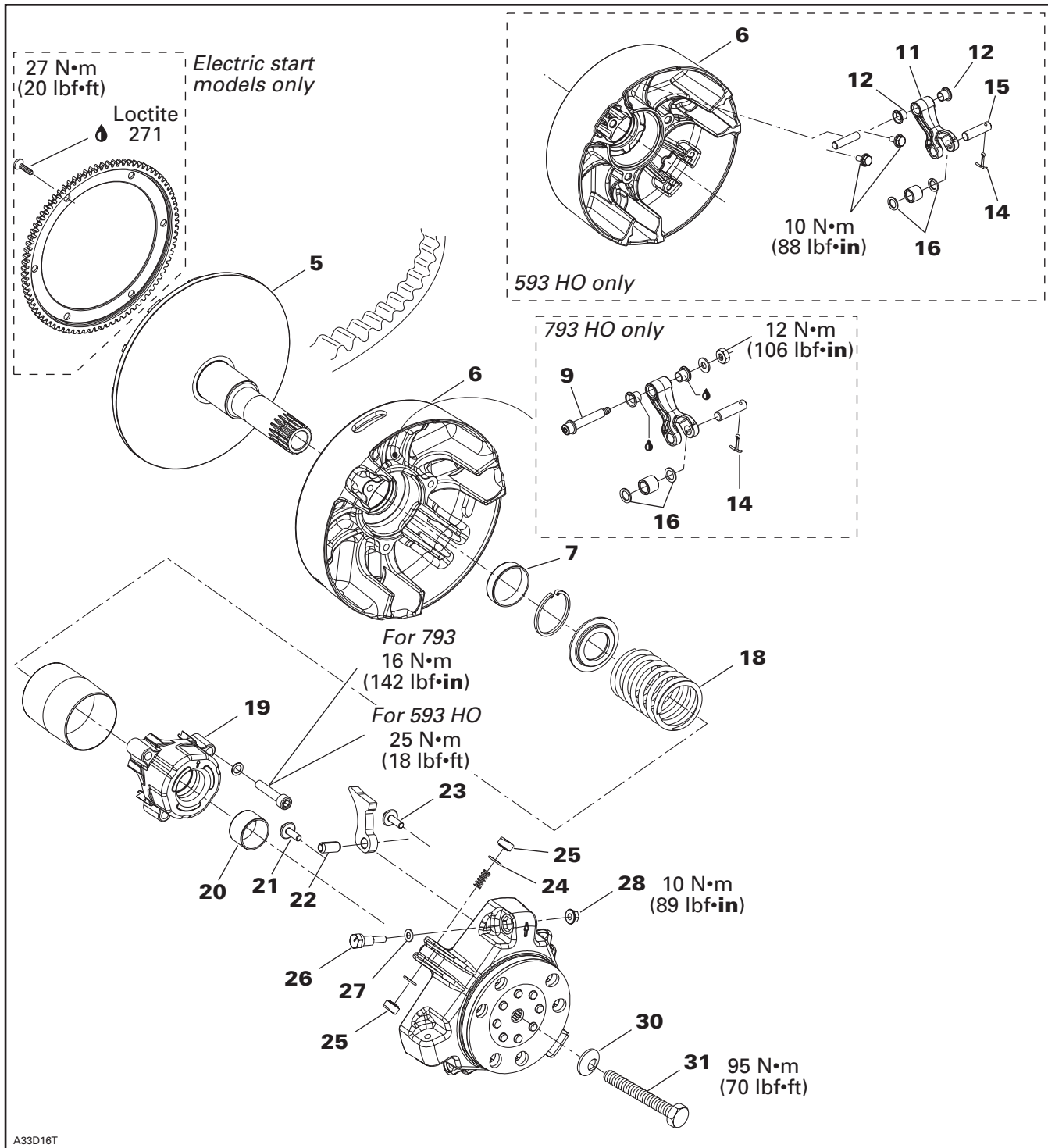

A33D16T

GENERAL

Some drive pulley components (return spring, ramp) can be changed to improve vehicle performance in high altitude regions. A service bulletin will give information about calibration according to altitude.

CAUTION: Such modifications should only be performed by experienced mechanics since they can greatly affect vehicle performance. Verify spring specifications before installation. Do not only refer to the spring color code.

NOTE: TRA drive pulley stands for Total Range Adjustable drive pulley.

⚠ WARNING

Any drive pulley repairs must be performed by an authorized Bombardier snowmobile dealer. Sub-component installation and assembly tolerances require strict adherence to procedures detailed.

REMOVAL

30,31, Conical Spring Washer and Screw

Use holder (P/N 529 035 674).

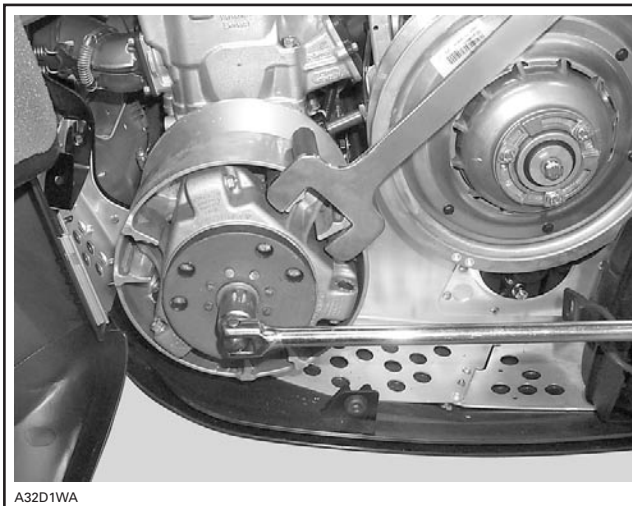

Insert the tool in sliding flange tower

⚠ WARNING

Never use any type of impact wrench at drive pulley removal and installation.

Remove retaining screw.

To remove drive pulley ass'y and/or fixed half from engine, use puller (P/N 529 022 400) for liquid cooled models.

CAUTION: These pulleys have metric threads. Do not use imperial threads puller. Always tighten puller by hand to ensure that the drive pulley has the same type of threads (metric vs imperial) prior to fully tightening.

To Remove Drive Pulley Ass'y:

Retain drive pulley with clutch holder.
Install puller in pulley shaft then tighten.

DISASSEMBLY

1,2, Screw and Ring Gear

CAUTION: Retaining screws must be heated before disassembly. Do not exceed 150°C (300°F).

5,6, Fixed and Sliding Half

CAUTION: Do not tap on governor cup.

Screw puller into fixed half shaft about 13 mm (1/2 in). Raise drive pulley and hold it by the sliding half while knocking on puller head to disengage fixed half.

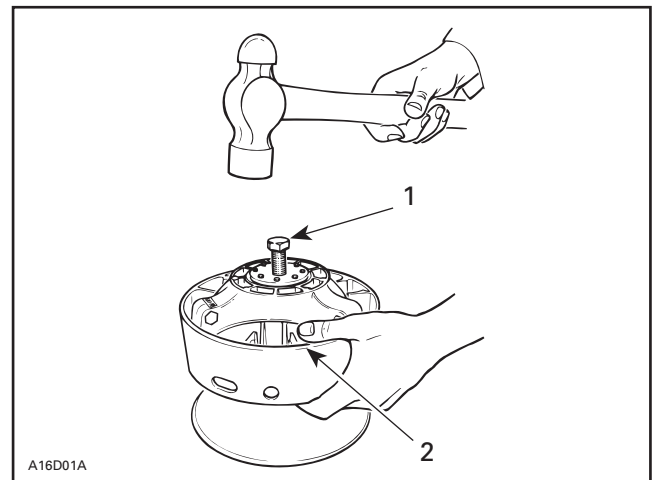

TYPICAL

- 1. Puller
- 2. Holding sliding half

NOTE: No components marking is required before disassembling this drive pulley since it has factory mark and arrows as indexing reference.

SECTION 05 - DRIVE SYSTEM

32, Cushion Drive

CAUTION: Do not disassemble cushion drive. Governor cup and cushion drive are factory balanced as an assembly.

25,29, Slider Shoe and Governor Cup

Carefully lift governor cup until slider shoes come at their highest position into guides.

Hold a slider shoe set then carefully lift its housing and remove slider shoes. Proceed the same way for other housings lifting one at a time.

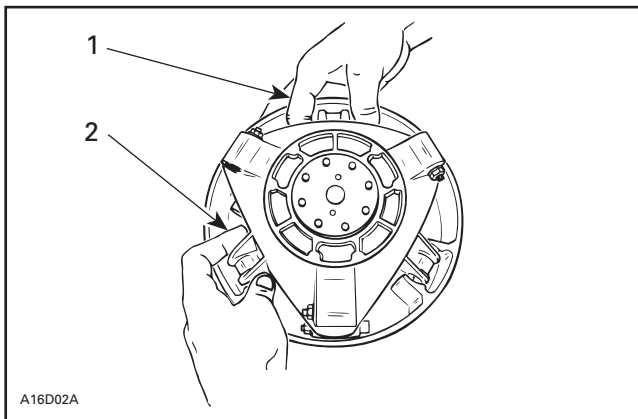

1. Hold slider shoes
2. Lift one housing at a time

NOTE: To ease disassembly, forks (P/N 529 005 500) should be used to hold slider shoes prior to removing governor cup.

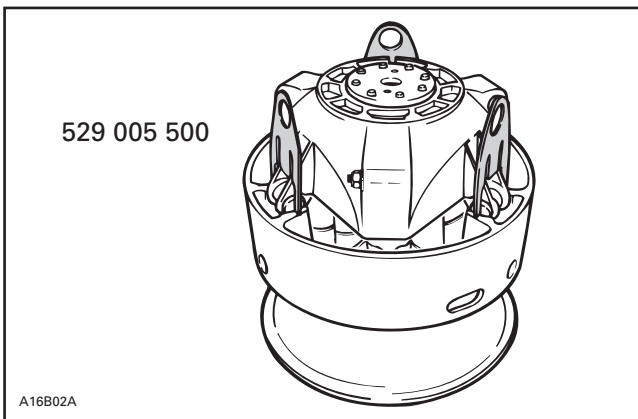

19, Spring Cover Ass'y

It is pushed by clutch spring pressure.

⚠ WARNING

Clutch spring is very strong. Never attempt to remove spring cover without the recommended tools.

Use spring compressor (P/N 529 035 524).
Install support guide.

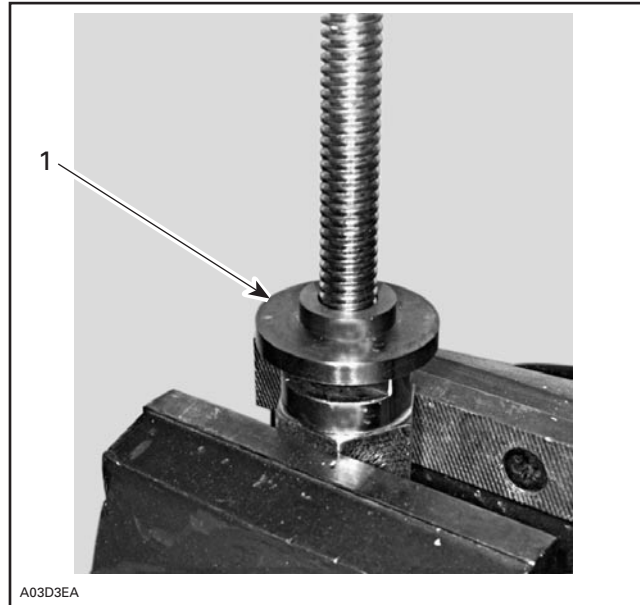

1. Support guide

Install sliding half then a second support guide. These support guides will prevent bushing damages.

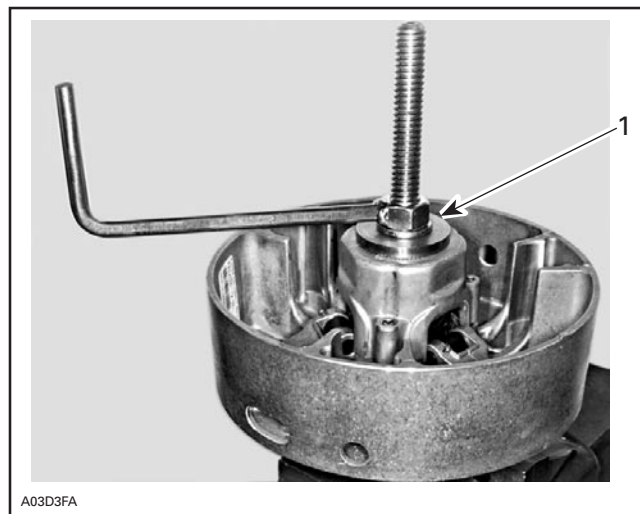

1. Support guide

Remove 3 Allen screws retaining spring cover then unscrew compressor.

CLEANING

5,6, Fixed and Sliding Half

Clean pulley faces and shaft with fine steel wool and dry cloth.

5, Fixed Half and Crankshaft End

Parts must be at room temperature before cleaning.

Using a paper towel with cleaning solvent, clean crankshaft tapered end and the taper inside the fixed half of the drive pulley, crankshaft threads and retaining screw threads.

WARNING

This procedure must be performed in a well-ventilated area.

CAUTION: Avoid contact between cleaner and crankshaft seal because damage may occur.

Remove all hardened oil deposits that have baked on crankshaft and pulley tapered surfaces with coarse or medium steel wool and/or sand paper no. 600.

CAUTION: Do not use any other type of abrasive.

Reclean mounting surfaces with paper towel and cleaning solvent.

Wipe off the mounting surfaces with a clean, dry paper towel.

CAUTION: Mounting surfaces must be free of any oil, cleaner or towel residue.

7,20, Bushing

Only use petrol base cleaner when cleaning bushings.

CAUTION: Do not use acetone to clean bushing.

INSPECTION

Drive pulley should be inspected annually.

16,17, Thrust Washer and Roller

Check roller for roundness of external diameter. Check thrust washer for thickness wear. Replace as required.

CAUTION: Ensure rollers are in good condition. Replace as required.

9,12, Fitting Bolt Ass'y and Flanged Bushing

Check for wear, replace as required.

24,25, O-Ring and Slider Shoe

Check if O-rings are cracked, cut or crushed. Replace as required.

Check slider shoes for wear. Replace if groove is not apparent on top.

5,29, Fixed Half and Governor Cup

Inspect splines and free play between both parts. Maximum free play is 0.5 mm (.020 in) measured at calibration screw radius. Replace if required.

7,20, Sliding Half and Spring Cover Bushing

Visually inspect coating. Replace if worn.

Sliding Half Bushing Replacement

This bushing is not replacable. If worn out, replace sliding half ass'y.

Spring Cover Bushing Replacement

Under normal use there is no need to replace this bushing.

Mount compressor (P/N 529 035 524) in a vise.

Use tools (P/N 529 035 932 and 529 035 931) to remove old bushing.

CAUTION: Bushing must be bonded with retaining compound.

Apply retaining compound Loctite 609 outside of bushing then press it down to counterbore from outside end.

CAUTION: Insert bushing from sliding half side (inner side) of spring cover.

ASSEMBLY

NOTE: This drive pulley is lubrication free. Do not lubricate any component.

1,2,3, Screw, Ring Gear and Loctite 271

Apply Loctite 271 (P/N 413 702 900) on threads and then torque to 27 N•m (20 lbf•ft).

SECTION 05 - DRIVE SYSTEM

26,27,28, Calibration Screw, Washer and Locking Nut

When installing calibration screw, make sure to install washer as shown.

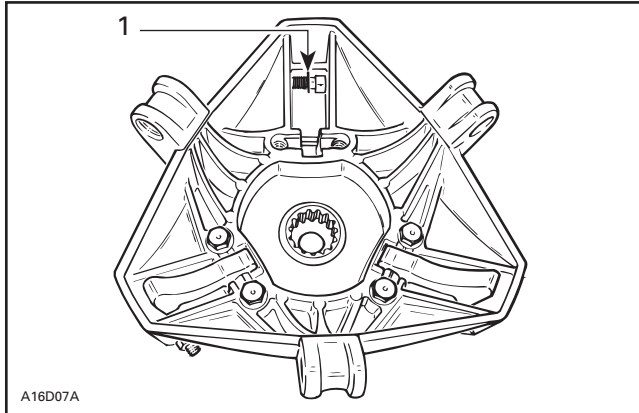

1. Washer

Torque locking nut to 10 N•m (89 lbf•in).

15, Pin

Always use the same type of pin as originally installed when servicing. Different types have different weights for calibration purpose. Refer to TECHNICAL DATA.

21,22,23, Screw, Dowel Tube and Ramp

Insert dowel tube from chamfered side. Make sure ramp is centered on dowel tube.

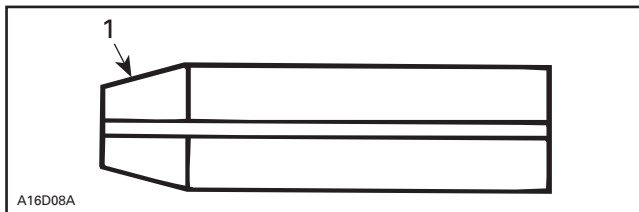

1. Chamfered side

Position dowel tube split at the angle A.

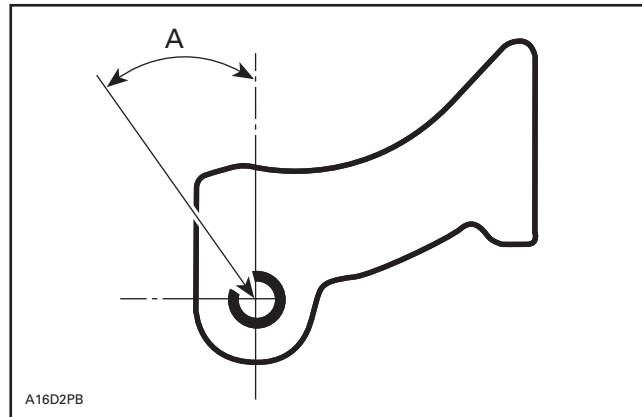

| MODEL | ANGLE (A) |
|--------------|------------------|
| With TRA III | $45 \pm 3^\circ$ |

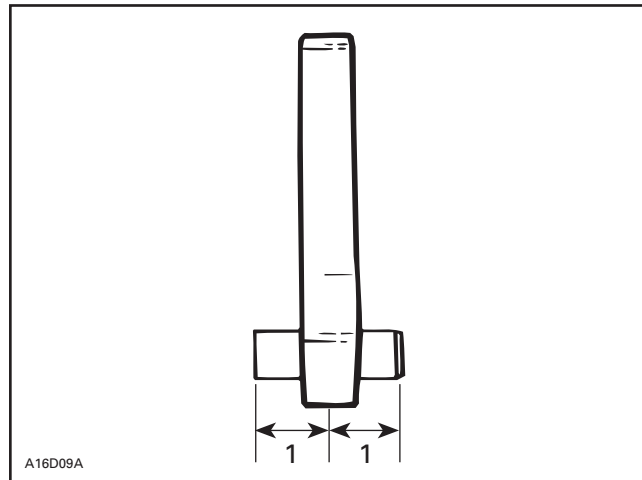

1. Equal distance

Torque screws to 10 N•m (89 lbf•in).

9,11,13,14, Screw, Lever Ass'y, Nut and Cotter Pin

NOTE: While installing lever assemblies make sure that the curved sides of the levers are outwards as shown.



Always install lever assemblies so that cotter pins are on the shown side. Besides install cotter pin head on top when lever is sat at bottom of sliding half. Bend cotter pin ends to sit perfectly against lever.

⚠ WARNING

Whenever replacing centrifugal levers, always replace all 3 at the same time. Otherwise, drive pulley misbalancing will occur because of levers difference.

793 Engine Equipped Models Only

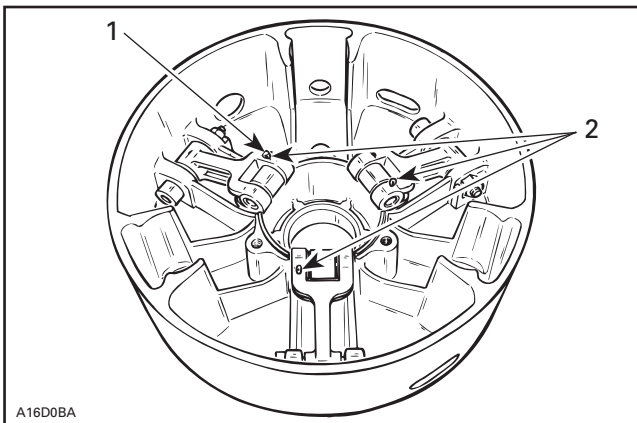

TYPICAL

1. Head on top
2. All on the same side

593 HO Engine Equipped Models Only

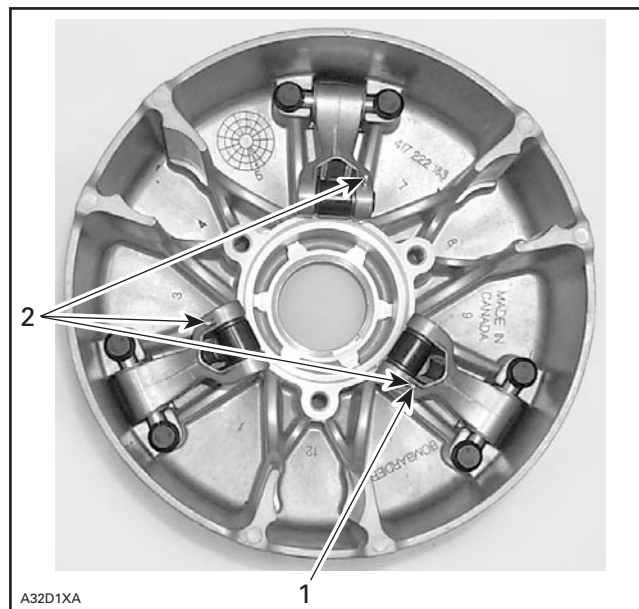

1. Head on top
2. All on the same side

All Models

CAUTION: Lever assemblies must be installed so that cotter pins are on the same side.

Torque nuts to 12 N•m (106 lbf•in).

CAUTION: Lever ass’y and rollers must move easily after installation.

5,6,18,19, Fixed Half, Sliding Half, Spring, Spring Cover and Screw

To install spring cover, use spring compressor (P/N 529 035 524).

Assemble fixed and sliding halves. Note that fixed halves have different cone angle. Match cone angle with crankshaft.

Lift sliding half against spring cover and align spring cover arrow with sliding half mark.

SECTION 05 - DRIVE SYSTEM

793 Engine Equipped Models Only

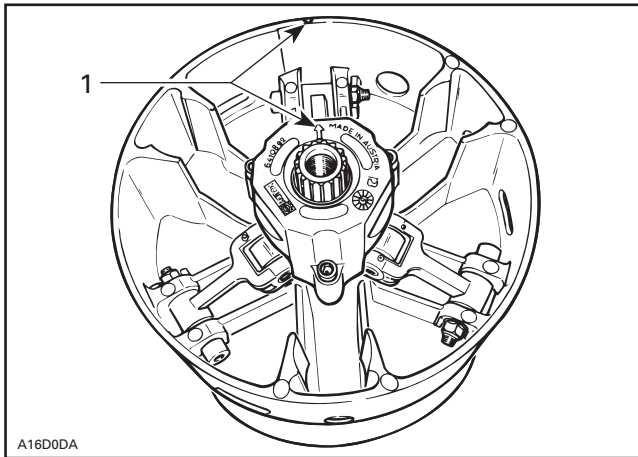

TYPICAL

1. Align

593 HO Engine Equipped Models Only

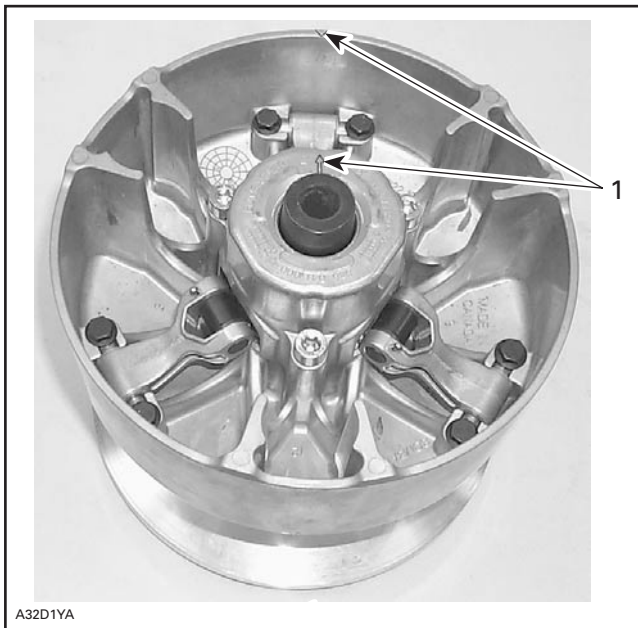

1. Align

All Models

Tighten screws to proper torque as mentioned in exploded view.

6,25,29, Sliding Half, Slider Shoe and Governor Cup

To install governor cup, use following tool:

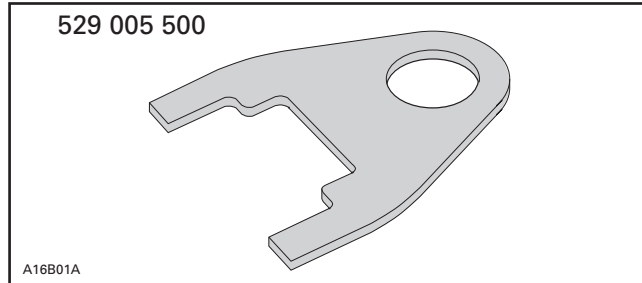

Insert spring and slider shoes into governor cup so that groove in each slider shoe is vertical to properly slide in guides.

CAUTION: Make sure O-rings are installed on slider shoes and that grooves are positioned vertically.

Install fork (P/N 529 005 500) into slider shoe grooves to maintain them for governor cup installation. Proceed on 3 set of slider shoes.

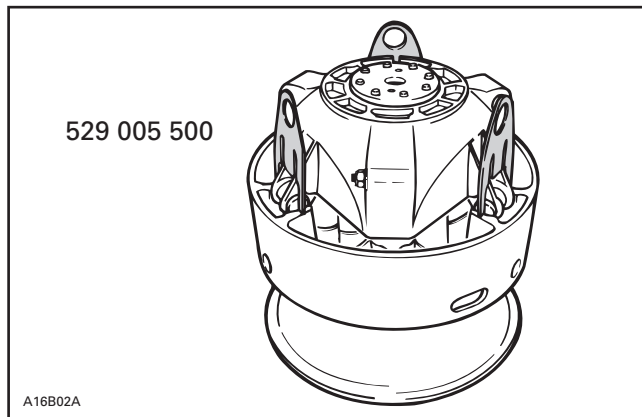

TYPICAL

Make sure to align governor cup arrow with sliding half and fixed half mark.

NOTE: If fixed half has no mark, align governor cup mark with segment no. 1 of inner half. Segments are identified on engine side.

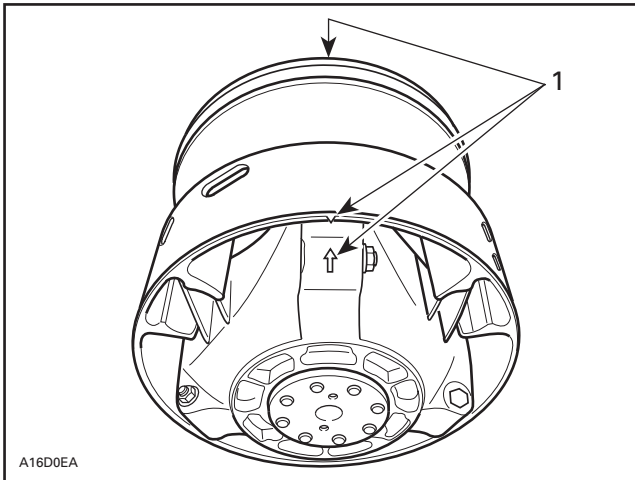

TYPICAL

1. Align

Carefully slide governor cup into sliding half. Align mark of governor cup with mark of fixed half.

Remove forks and push governor cup so that its splines engage with fixed half shaft splines.

CAUTION: Make sure splines of both parts are fully engaged.

INSTALLATION

⚠ WARNING

Do not apply anti-seize or any lubricant on crankshaft and drive pulley tapers.

⚠ WARNING

Never use any type of impact wrench at drive pulley removal and installation.

Clean mounting surfaces as described in CLEANING above.

Drive Pulley Ass'y

The following installation procedure must be strictly adhered to.

Install drive pulley on crankshaft extension.

Install a new conical spring washer with its concave side towards drive pulley then install screw.

⚠ WARNING

Never substitute conical spring washer and/or screw with jobber ones. Always use Bombardier genuine parts for this particular case.

Use holder. See removal procedure.

Torque screw to 80 to 100 N•m (59 to 74 lbf•ft).

Install drive belt and guard.

Raise and block the rear of the vehicle and support it with a mechanical stand.

⚠ WARNING

Ensure that the track is free of particles which could be thrown out while track is rotating. Keep hands, tools, feet and clothing clear of track. Ensure nobody is standing near the vehicle.

Accelerate the vehicle at low speed (maximum 30 km/h (20 MPH)) and apply the brake, repeat 5 times.

Retorque screw to 90 to 100 N•m (66 to 74 lbf•ft).

⚠ WARNING

After 10 hours of operation the transmission system of the vehicle must be inspected to ensure the retaining screw is properly torqued.

DRIVE PULLEY ADJUSTMENT

The drive pulley is factory calibrated to transmit maximum engine power at a predefined RPM. Factors such as ambient temperature, altitude or surface condition may vary this critical engine RPM thus affecting snowmobile efficiency.

This adjustable drive pulley allows setting maximum engine RPM in the vehicle to maintain maximum power.

Calibration screws should be adjusted so that actual maximum engine RPM in vehicle matches with the maximum horsepower RPM given in TECHNICAL DATA.

NOTE: Use precision digital tachometer for engine RPM adjustment.

NOTE: The adjustment has an effect on high RPM only.

To adjust, modify ramp end position by turning calibration screws.

SECTION 05 - DRIVE SYSTEM

26,28,29, Calibration Screw, Locking Nut and Governor Cup

Calibration screw has a notch on top of its head.

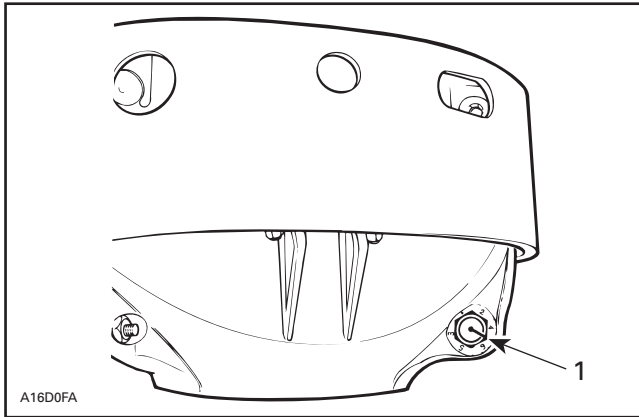

1. Notch

Governor cup has 6 positions numbered 2 to 6. Note that in position 1 there is no stamped number (due to its location on casting).

See TECHNICAL DATA for original setting.

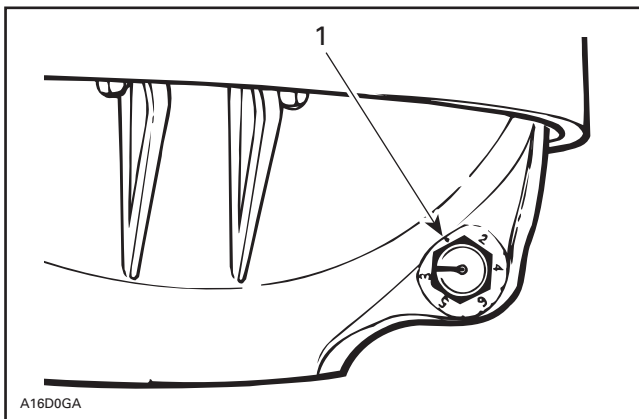

1. Position 1 (not numbered)

Each number modifies maximum engine RPM by about 200 RPM.

Lower numbers decrease engine RPM in steps of 200 RPM and higher numbers increase it in steps of 200 RPM.

Example:

Calibration screw is set at position 3 and is changed to position 5. So maximum engine RPM is increased by about 400 RPM.

To Adjust:

Just loosen locking nut enough to pull calibration screw **partially** out and adjust to desired position. Do not completely remove the locking nut. Torque locking nuts to 10 N•m (89 lbf•in).

CAUTION: Do not completely remove calibration screw otherwise its inside washer will fall off.

CAUTION: Always adjust all 3 calibration screws and make sure they are all set at the same number.

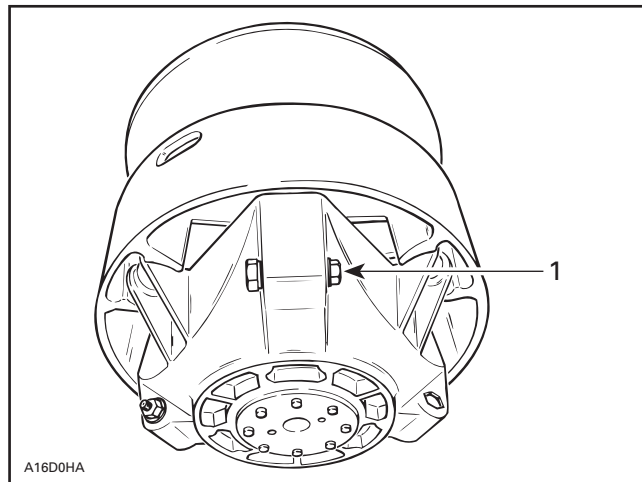

TYPICAL

1. Loosen just enough to permit rotating of calibration screw

SECTION 05 - DRIVE SYSTEM

KIT P/N 486 400 003 TRA III WEIGHT SET-UP FOR PIN

From 12.4 to 22.15 grams

| PART DESCRIPTION | PART NUMBER | WEIGHT (G) | KIT QTY |
|------------------|-------------|------------|---------|
| Pin 35.75 mm | 417 222 595 | 12.4 | 3 |
| Slug 14 mm | 486 400 004 | 5.044 | 3 |
| Slug 23 mm | 486 400 005 | 8.287 | 3 |
| Set screw 6 mm | 206 260 699 | 0.73 | 9 |
| Set screw 12 mm | 206 261 299 | 1.68 | 3 |
| Set screw 16 mm | 206 261 699 | 2.35 | 3 |
| Set screw 20 mm | 206 262 099 | 3.02 | 3 |
| Set screw 25 mm | 206 262 599 | 3.81 | 3 |

| 13.86 GRAMS SET-UP | | | |
|--------------------|-------------|------------|-----|
| PART DESCRIPTION | PART NUMBER | WEIGHT (G) | QTY |
| Pin 35.75 mm | 417 222 595 | 12.4 | 1 |
| Set screw 6 mm | 206 260 699 | 0.73 | 2 |



A32D3A4

| 14.81 GRAMS SET-UP | | | |
|--------------------|-------------|------------|-----|
| PART DESCRIPTION | PART NUMBER | WEIGHT (G) | QTY |
| Pin 35.75 mm | 417 222 595 | 12.4 | 1 |
| Set screw 6 mm | 206 260 699 | 0.73 | 1 |
| Set screw 12 mm | 206 261 299 | 1.68 | 1 |



A32D3B4

| 15.54 GRAMS SET-UP | | | |
|--------------------|-------------|------------|-----|
| PART DESCRIPTION | PART NUMBER | WEIGHT (G) | QTY |
| Pin 35.75 mm | 417 222 595 | 12.4 | 1 |
| Set screw 6 mm | 206 260 699 | 0.73 | 2 |
| Set screw 12 mm | 206 261 299 | 1.68 | 1 |



A32D3C4

| 16.21 GRAMS SET-UP | | | |
|--------------------|-------------|------------|-----|
| PART DESCRIPTION | PART NUMBER | WEIGHT (G) | QTY |
| Pin 35.75 mm | 417 222 595 | 12.4 | 1 |
| Set screw 25 mm | 206 262 599 | 3.81 | 1 |



A32D3D4

| 16.43 GRAMS SET-UP | | | |
|--------------------|-------------|------------|-----|
| PART DESCRIPTION | PART NUMBER | WEIGHT (G) | QTY |
| Pin 35.75 mm | 417 222 595 | 12.4 | 1 |
| Set screw 16 mm | 206 261 699 | 2.35 | 1 |
| Set screw 12 mm | 206 261 299 | 1.68 | 1 |



A32D3E4

| 13.13 GRAMS SET-UP | | | |
|--------------------|-------------|------------|-----|
| PART DESCRIPTION | PART NUMBER | WEIGHT (G) | QTY |
| Pin 35.75 mm | 417 222 595 | 12.4 | 1 |
| Set screw 6mm | 206 260 699 | 0.73 | 1 |



A32D3F4

| 14.59 GRAMS SET-UP | | | |
|--------------------|-------------|------------|-----|
| PART DESCRIPTION | PART NUMBER | WEIGHT (G) | QTY |
| Pin 35.75 mm | 417 222 595 | 12.4 | 1 |
| Set screw 6mm | 206 260 699 | 0.73 | 3 |



A32D3G4

SECTION 05 - DRIVE SYSTEM

| 15.42 GRAMS SET-UP | | | |
|--------------------|-------------|------------|-----|
| PART DESCRIPTION | PART NUMBER | WEIGHT (G) | QTY |
| Pin 35.75 mm | 417 222 595 | 12.4 | 1 |
| Set screw 20 mm | 206 262 099 | 3.02 | 1 |



A32D3H4

| 16.15 GRAMS SET-UP | | | |
|--------------------|-------------|------------|-----|
| PART DESCRIPTION | PART NUMBER | WEIGHT (G) | QTY |
| Pin 35.75 mm | 417 222 595 | 12.4 | 1 |
| Set screw 20 mm | 206 262 099 | 3.02 | 1 |
| Set screw 6 mm | 206 260 699 | 0.73 | 1 |



A32D3I4

| 16.27 GRAMS SET-UP | | | |
|--------------------|-------------|------------|-----|
| PART DESCRIPTION | PART NUMBER | WEIGHT (G) | QTY |
| Pin 35.75 mm | 417 222 595 | 12.4 | 1 |
| Set screw 6 mm | 206 260 699 | 0.73 | 3 |
| Set screw 12 mm | 206 261 299 | 1.68 | 1 |



A32D3J4

| 16.88 GRAMS SET-UP | | | |
|--------------------|-------------|------------|-----|
| PART DESCRIPTION | PART NUMBER | WEIGHT (G) | QTY |
| Pin 35.75 mm | 417 222 595 | 12.4 | 1 |
| Set screw 20 mm | 206 262 099 | 3.02 | 1 |
| Set screw 6 mm | 206 260 699 | 0.73 | 2 |



A32D3K4

| 16.94 GRAMS SET-UP | | | |
|--------------------|-------------|------------|-----|
| PART DESCRIPTION | PART NUMBER | WEIGHT (G) | QTY |
| Pin 35.75 mm | 417 222 595 | 12.4 | 1 |
| Set screw 25 mm | 206 262 599 | 3.81 | 1 |
| Set screw 6 mm | 206 260 699 | 0.73 | 1 |



A32D3L4

| 18.17 GRAMS SET-UP | | | |
|--------------------|-------------|------------|-----|
| PART DESCRIPTION | PART NUMBER | WEIGHT (G) | QTY |
| Pin 35.75 mm | 417 222 595 | 12.4 | 1 |
| Set screw 6 mm | 206 260 699 | 0.73 | 1 |
| Slug 14 mm | 486 400 004 | 5.044 | 1 |



A32D3M4

| 19.63 GRAMS SET-UP | | | |
|--------------------|-------------|------------|-----|
| PART DESCRIPTION | PART NUMBER | WEIGHT (G) | QTY |
| Pin 35.75 mm | 417 222 595 | 12.4 | 1 |
| Set screw 6 mm | 206 260 699 | 0.73 | 3 |
| Slug 14 mm | 486 400 004 | 5.044 | 1 |



A32D3N4

| 20.52 GRAMS SET-UP | | | |
|--------------------|-------------|------------|-----|
| PART DESCRIPTION | PART NUMBER | WEIGHT (G) | QTY |
| Pin 35.75 mm | 417 222 595 | 12.4 | 1 |
| Set screw 6 mm | 206 260 699 | 0.73 | 1 |
| Set screw 16 mm | 206 261 699 | 2.35 | 1 |
| Slug 14 mm | 486 400 004 | 5.044 | 1 |



A32D3O4

SECTION 05 - DRIVE SYSTEM

| 22.15 GRAMS SET-UP | | | |
|--------------------|-------------|------------|-----|
| PART DESCRIPTION | PART NUMBER | WEIGHT (G) | QTY |
| Pin 35.75 mm | 417 222 595 | 12.4 | 1 |
| Set screw 6 mm | 206 260 699 | 0.73 | 2 |
| Slug 23 mm | 486 400 005 | 8.287 | 1 |



A32D3P4

| 19.85 GRAMS SET-UP | | | |
|--------------------|-------------|------------|-----|
| PART DESCRIPTION | PART NUMBER | WEIGHT (G) | QTY |
| Pin 35.75 mm | 417 222 595 | 12.4 | 1 |
| Set screw 6 mm | 206 260 699 | 0.73 | 1 |
| Set screw 12 mm | 206 261 299 | 1.68 | 1 |
| Slug 14 mm | 486 400 004 | 5.044 | 1 |



A32D3S4

| 17.16 GRAMS SET-UP | | | |
|--------------------|-------------|------------|-----|
| PART DESCRIPTION | PART NUMBER | WEIGHT (G) | QTY |
| Pin 35.75 mm | 417 222 595 | 12.4 | 1 |
| Set screw 6 mm | 206 260 699 | 0.73 | 1 |
| Set screw 16 mm | 206 261 699 | 2.35 | 1 |
| Set screw 12 mm | 206 261 299 | 1.68 | 1 |



A32D3Q4

| 21.42 GRAMS SET-UP | | | |
|--------------------|-------------|------------|-----|
| PART DESCRIPTION | PART NUMBER | WEIGHT (G) | QTY |
| Pin 35.75 mm | 417 222 595 | 12.4 | 1 |
| Set screw 6 mm | 206 260 699 | 0.73 | 1 |
| Slug 23 mm | 486 400 005 | 8.287 | 1 |



A32D3T4

| 18.90 GRAMS SET-UP | | | |
|--------------------|-------------|------------|-----|
| PART DESCRIPTION | PART NUMBER | WEIGHT (G) | QTY |
| Pin 35.75 mm | 417 222 595 | 12.4 | 1 |
| Set screw 6 mm | 206 260 699 | 0.73 | 2 |
| Slug 14 mm | 486 400 004 | 5.044 | 1 |



A32D3R4

SECTION 05 - DRIVE SYSTEM

TRA III RAMP PROFILES

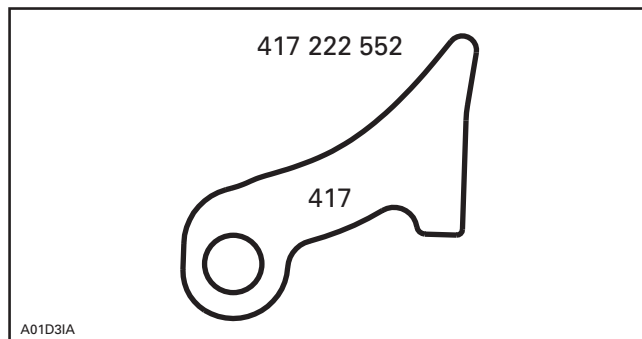
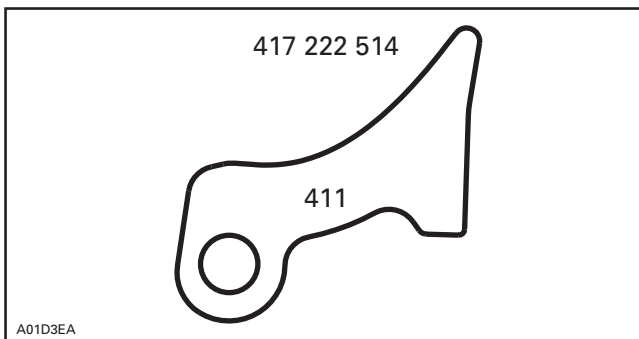
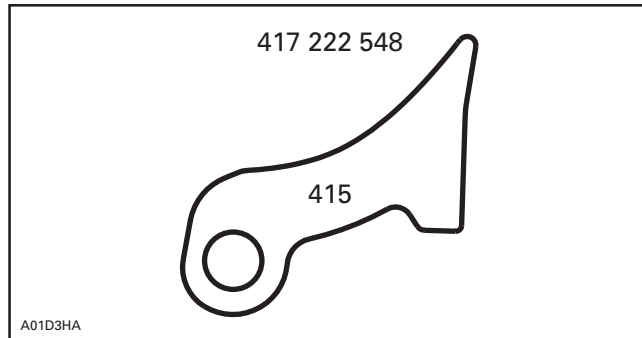
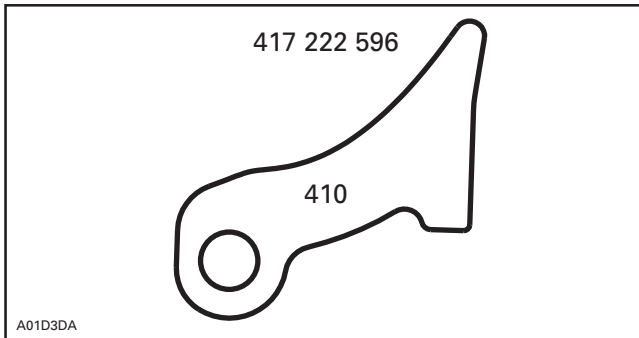
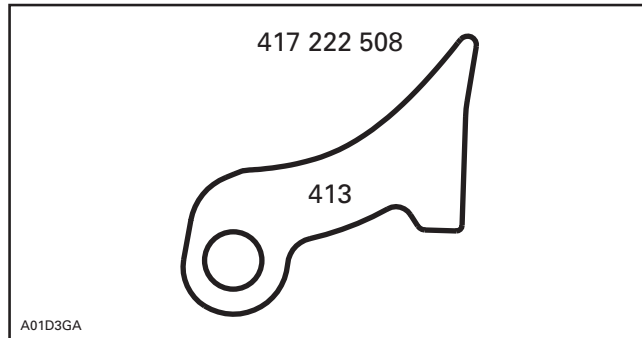
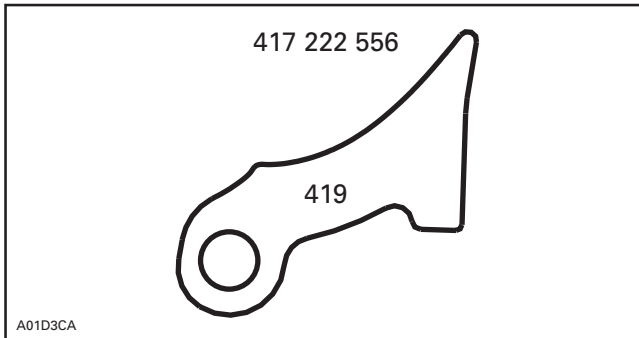
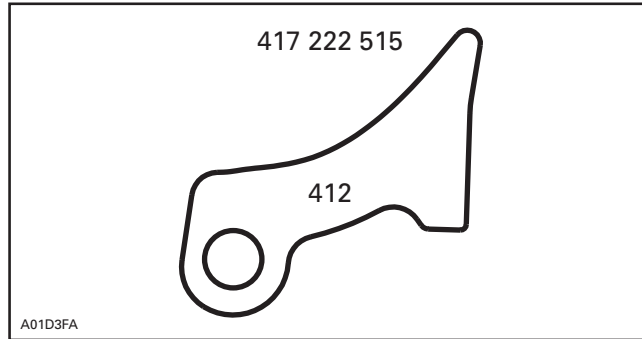
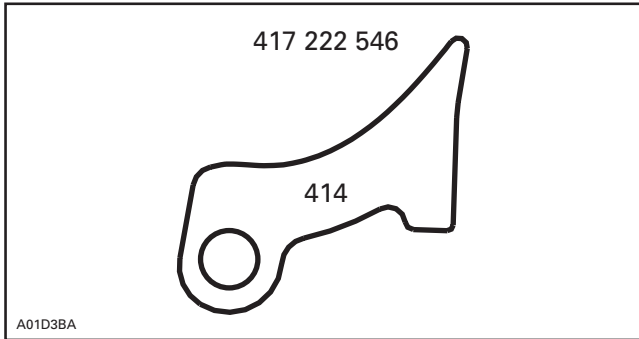

SECTION 05 - DRIVE SYSTEM

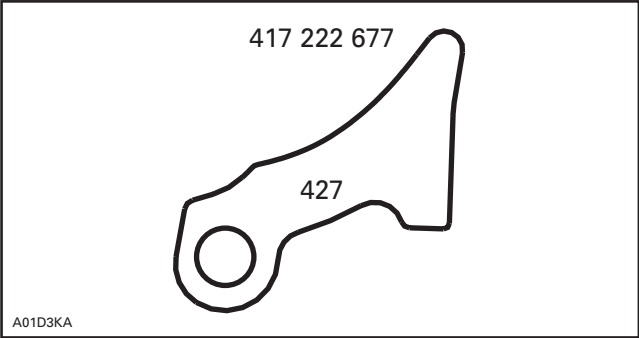
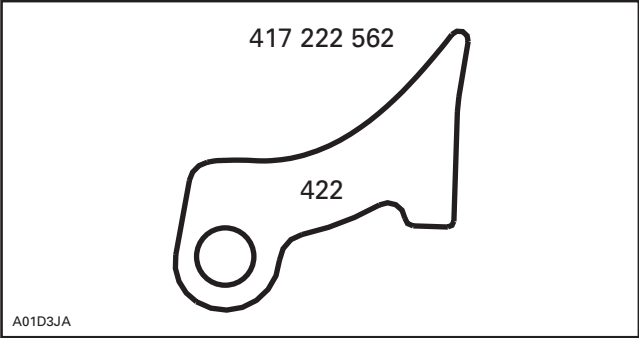

SECTION 05 - DRIVE SYSTEM

TRA SPRINGS CHART

| FORCE @ POUNDS ± 5% 74 mm - 41 mm 2.9 in - 1.6 in | P/N BOMBARDIER | COLOR CODE | WIRE DIA. | | FREE LENGTH | |
|--|-------------------|-----------------|--------------|----------------|-------------|-----|
| | | | mm | in | mm | in |
| 70 - 170 | 414 689 800 | RED - RED | 5.26 5.00 | 0.207 0.197 | 99 | 3.9 |
| 70 - 200 | 415 015 200 | RED - ORANGE | 5.26 | 0.207 | 94 | 3.7 |
| 70 - 230 | 414 817 500 | RED - YELLOW | 5.54 | 0.218 | 89 | 3.5 |
| 70 - 260 | 414 689 200 | RED - GREEN | 5.94 | 0.234 | 88 | 3.5 |
| 70 - 290 | 414 691 500 | RED - BLUE | 5.94 | 0.234 | 86 | 3.4 |
| 70 - 320 | 414 701 000 | RED - PURPLE | 6.35 | 0.250 | 85 | 3.3 |
| 100 - 170 | 414 993 000 | YELLOW - RED | 4.88 | 0.192 | 128 | 5.0 |
| 100 - 200 | 414 689 700 | YELLOW - ORANGE | 5.26 | 0.207 | 110 | 4.3 |
| 100 - 230 | 414 748 600 | YELLOW - YELLOW | 5.54 5.41 | 0.218 0.213 | 102 | 4.0 |
| 100 - 260 | 414 742 100 | YELLOW - GREEN | 5.72 5.94 | 0.225 0.234 | 96 | 3.8 |
| 100 - 290 | 414 818 000 | YELLOW - BLUE | 5.94 | 0.234 | 97 | 3.8 |
| 100 - 320 | 414 678 400 | YELLOW - PURPLE | 6.35 6.17 | 0.250 0.243 | 93 | 3.7 |
| 130 - 200 | 414 639 000 | BLUE - ORANGE | 4.88 5.00 | 0.192 0.197 | 145 | 5.7 |
| 130 - 230 | 414 689 500 | BLUE - YELLOW | 5.26 | 0.207 | 125 | 4.9 |
| 130 - 260 | 414 817 700 | BLUE - GREEN | 5.54 | 0.218 | 109 | 4.3 |
| 130 - 290 | 414 689 400 | BLUE - BLUE | 5.94 | 0.234 | 104 | 4.1 |
| 130 - 320 | 414 817 800 | BLUE - PURPLE | 6.17 5.94 | 0.243 0.234 | 98 | 3.9 |
| 130 - 350 | 414 916 300 | BLUE - PINK | 6.35 6.17 | 0.250 0.243 | 96 | 3.8 |
| 150 - 240 | 414 605 600 | WHITE | 5.26 | 0.207 | 135 | 5.3 |
| 160 - 230 | 415 015 300 | PURPLE - YELLOW | 4.88 | 0.192 | 158 | 6.2 |
| 160 - 260 | 415 015 400 | PURPLE - GREEN | 5.26 | 0.207 | 133 | 5.2 |
| 160 - 270 | 414 605 500 | YELLOW | 5.26 5.54 | 0.207 0.218 | 130 | 5.1 |
| 160 - 290 | 415 034 900 | PURPLE - BLUE | 5.54 5.72 | 0.218 0.225 | 120 | 4.7 |

SECTION 05 - DRIVE SYSTEM

| FORCE @ POUNDS ± 5% 74 mm - 41 mm 2.9 in - 1.6 in | P/N BOMBARDIER | COLOR CODE | WIRE DIA. | | FREE LENGTH | |
|--|-------------------|---|--------------|----------------|-------------|------------|
| | | | mm | in | mm | in |
| 160 - 320 | 414 817 900 | PURPLE - PURPLE | 5.72 5.94 | 0.225 0.234 | 111 | 4.4 |
| 160 - 350 | 414 949 500 | PURPLE - PINK | 5.94 6.17 | 0.234 0.243 | 105 | 4.1 |
| 185 - 410 | 415 019 500 | "ALL" BLACK | 6.35 | 0.250 | 105 | 4.1 |
| 200 - 290 | 414 768 200 | GREEN - BLUE | 5.26 | 0.207 | 156 | 6.1 |
| 200 - 320 | 414 762 800 | GREEN - PURPLE | 5.54 5.72 | 0.218 0.225 | 135 | 5.3 |
| 200 - 350 | 414 756 900 | GREEN - PINK | 5.72 | 0.225 | 126 | 5.0 |
| 200 - 380 | 414 222 371 | GREEN - WHITE | 5.94 | 0.234 | | |
| 230 - 350 | 415 074 800 | PINK - PINK | 5.54 | 0.218 | 143 | 5.6 |
| 230 - 380 | 414 991 400 | PINK - WHITE (OLD) RED - WHITE | 5.94 5.72 | 0.234 0.225 | 128 134 | 5.0 5.3 |
| 230 - 390 | 415 019 600 | GREEN | 5.94 | 0.234 | 126 | 5.0 |
| 230 - 410 | 415 019 700 | RED | 5.94 | 0.234 | 120 | 4.7 |
| 240 - 430 | 415 019 800 | BLUE | 5.94 | 0.234 | 120 | 4.7 |
| 250 - 380 | 417 222 004 | WHITE - WHITE (OLD) GREEN - WHITE | 5.72 | 0.225 | 140 | 5.5 |
| 250 - 460 | 415 019 900 | PINK | 6.17 | 0.243 | 116 | 4.6 |
| 260 - 420 | 417 222 164 | WHITE - SILVER (OLD) ORANGE | 5.94 | 0.234 | 135 | 5.3 |
| 280 - 420 | 415 020 100 | GREEN - GREEN | 5.72 | 0.225 | 146 | 5.7 |
| 280 - 460 | 415 020 200 | RED - RED | 6.17 | 0.243 | 132 | 5.2 |
| 280 - 510 | 415 020 300 | BLUE - BLUE | 6.35 | 0.250 | 121 | 4.8 |
| 310 - 460 | 415 020 400 | PINK - PINK | 5.94 | 0.234 | 148 | 5.8 |
| 310 - 510 | 415 020 500 | ORANGE - ORANGE (OR) GOLD - GOLD | 6.17 | 0.243 | 132 | 5.2 |

Part numbers with a 486 prefix must be ordered from the Valcourt Race Dept. All others must be ordered from your local Ski-Doo dealer.

SECTION 05 - DRIVE SYSTEM

EFFECTS OF THE DRIVEN PULLEY SPRING

The driven pulley spring is needed to keep the plastic slider buttons in contact with the cam and to provide enough side force on the belt in the low gear position to allow initial acceleration while the torque rises to a point where the torque sensing cam begins to take over. At full load, the driven pulley spring has much less effect on the driven pulley shifting sequence than does the cam, especially at low shift ratios. At the part throttle loads at low ratios, the spring has the main effect on the shift characteristics of driven pulley.

Increases in the driven pulley spring preload will bring the engine speed up before the pulley starts shifting and will help backshift the clutch quicker. Decreasing the preload will allow a faster upshift but a slower backshift thus lowering the engine RPM.

NOTE: Control of the engine speed is done by calibrating the engine pulley not by adjusting the driven pulley spring preload. An attempt to lower the engine RPM by decreasing the spring preload in the driven pulley will result in belt slippage on acceleration. An attempt to increase engine RPM by increasing the preload will result in excessive drive belt wear and decreased efficiency in the transmission.

The driven pulley spring preload is listed in the basic specifications for all our machines. This preload tension will vary from 4 kg (9 lb) to 7.5 kg (17 lb) on models equipped with the TRA clutch.

The preload figure given in our specifications is quoted in kg (lb) of force for each machine, not in inch-pounds or foot-pounds of torque. A figure given in units of torque would require multiplying the radius of the pulley by the pull recorded on the scale. Our figures are quoted for each pulley size and it is only necessary to record the pull of the spring by attaching a scale to the rim of the pulley. The scale must be positioned at 90° to the radius of the pulley. Holding the fixed half of the pulley still, pull until the sliding half just begins to rotate. At this point, read the scale.

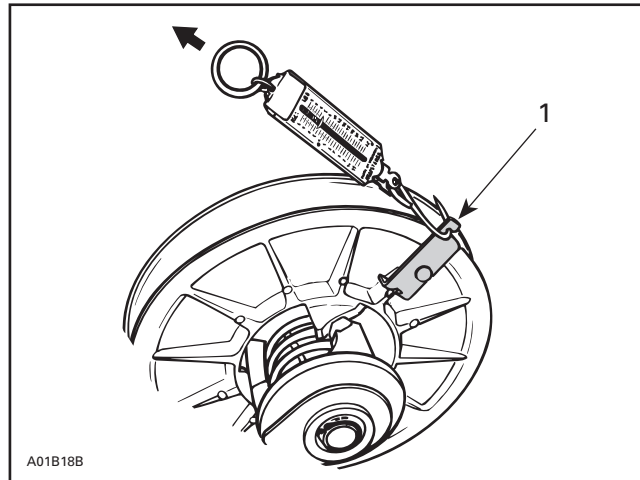

TYPICAL

1. Spring scale hook (P/N 529 030 900)

To change the spring tension, relocate the spring end in the sliding pulley half or reposition the spring end in the cam.

There are six holes available on a Formula cam. They are numbered 1-6. Most Formula driven pulleys have three adjustment holes in the sliding half. They are lettered A, B, C. When adjusting driven pulley tension, always refer to the tension in kg (lb) — not B-6 or A-5 hole positions for accuracy and repeatability. Moving the spring from one numbered hole to a hole adjacent will change the preload by 1.35-1.8 kg (3-4 lb). Remember, use the number and letters as references — measure the tension for accuracy. By using various combinations, the preload is adjustable from 5 to 35 pounds (depending on spring type).

The charts below will give an approximate reference for each spring position. It will vary with different springs and cam angles.

FORMULA DRIVEN CLUTCH PRELOAD

| WHITE SPRING/LBS | | | |
|------------------|----|----|----|
| POSITION | A | B | C |
| 1 | 26 | 29 | 24 |
| 2 | 21 | 23 | 20 |
| 3 | 16 | 19 | 15 |
| 4 | 11 | 14 | 10 |
| 5 | 7 | 10 | 6 |
| 6 | 3 | 5 | 1 |

| BEIGE SPRING/LBS | | | |
|------------------|------|------|------|
| POSITION | A | B | C |
| 1 | 14 | 16 | 12 |
| 2 | 9 | 11 | 7 |
| 3 | 4 | 6 | 2 |
| 4 | 28 | 30 | 26 |
| 5 | 23 | 25 | 21 |
| 6 | 18.5 | 20.5 | 16.5 |

Our procedure is as follows:

- Remove the drive belt and lock the parking brake.
- Using a reliable fish scale and our spring scale hook (P/N 529 030 900) pull perpendicular to the rim of the pulley until the moveable sheave begins to open. Record the reading on the fishscale.
- Next while the pulley is still being pulled open, relax the tension on the fish scale until the moveable pulley begins to close, record the reading.

- **Next add the two readings together and divide by two. This is the number we use as our reference.**
- Recording **only the pull** reading and this will definitely allow the driven pulley tension to be too low. This low tension will lead to a noticeable drop in peak RPM and a loss of top speed.

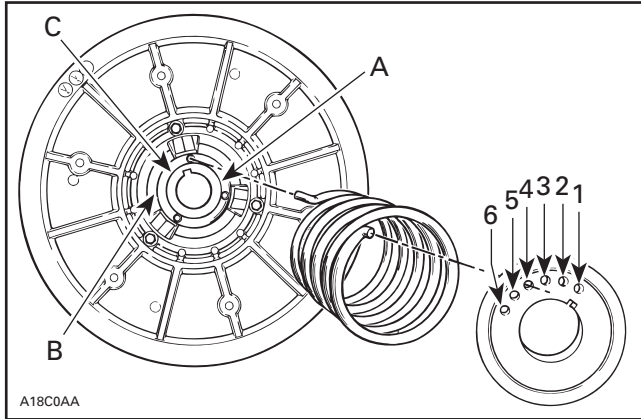

Letters and numbers shown in illustration are actual letters and numbers embossed on parts

NOTE: Always recheck torsional pre-load after adjusting.

By experimenting with them, you may find a more efficient combination of minimum side pressure yet adequate back shifting for your particular racing application.

| COLOR | WIRE DIAMETER | PART NUMBER |
|-------|---------------|-------------|
| BEIGE | .207 in | 414 558 900 |
| WHITE | .207 in | 504 152 070 |
| YL/BK | — | 486 104 000 |

Part numbers with a 486 prefix must be ordered from the Valcourt Race Dept. All others must be ordered from your local Ski-Doo dealer.

HPV 27 VSA CLUTCH SPRINGS

| PART NUMBER | COLOR | FREE LENGTH (MM) | WIRE DIA. (MM) | LOAD @ 61 MM | LOAD @ 35.2 MM |
|-------------|--------|------------------|----------------|-----------------|-----------------|
| 417 126 687 | BLACK | 88.8 | 6.17 | 700 N (157 lb) | 1350 N (303 lb) |
| 417 126 686 | RED | 81.6 | 6.35 | 600 N (135 lb) | 1350 N (303 lb) |
| 417 126 688 | GREEN | 98.5 | 5.94 | 800 N (180 lb) | 1350 N (303 lb) |
| 417 126 689 | BLUE | 130.5 | 5.25 | 700 N (157 lb) | 950 N (214 lb) |
| 414 978 300 | VIOLET | N/A | N/A | 1000 N (225 lb) | 1350 N (303 lb) |

SECTION 05 - DRIVE SYSTEM

EFFECTS OF THE DRIVEN PULLEY CAM

The purpose of the driven pulley cam is to sense the torque requirements of the drive axle and feed a portion of the engine torque, which has been applied to the driven pulley, back to the sliding half of the pulley. It is this side force that signals the downshift and provides side thrust to give traction to the drive belt.

The cam is acting like a screw pushing against the sliding half of the pulley. A large cam angle will act like a coarse thread while a small cam angle will act similar to a fine thread. The smaller the cam angle, the greater the side force on the sliding half of the pulley and the slower the upshift will be. This will result in higher engine RPM.

A larger cam angle will allow the pulley to upshift at a lower engine speed. Less side force will be exerted on the sliding half of the pulley and the pulley will upshift more rapidly.

On downshift, a smaller cam angle will backshift more easily and, again, tend to keep the engine RPM higher. A larger cam angle will be harder to downshift and will load the engine and reduce the RPM.

If all other variables in the pulleys are kept constant, a cam change with a smaller angle will result in a slower upshift and a faster downshift. Engine RPM will remain higher. A change to a cam with a larger angle will result in a faster upshift and the downshift will be slower. Engine RPM will be lower.

Remember the drive pulley signals or controls the upshift of the transmission while the driven pulley signals the downshift largely because of the effect of the cam.

The standard factory cam will probably work well for most **woods** type cross-countries, while a smaller angled cam may prove to be better for high speed lake cross-countries.

Top speed and low ET's are drag racers' and radar runners' most important concerns. Because backshifting is not at all important in these races, most racers experiment with larger cam angles for the fastest possible upshift.

Multi-angle cams are sometimes used by racers needing a good holeshoot. They generally work best on vehicles where no track spin is encountered. As a vehicle idles on the starting line, the exhaust temperature cools thus slightly lowering the optimum HP RPM of the engine. Because of this, a steeper (larger) angle cam can be used to upshift more quickly, and lower the RPM to work with the cooler exhaust. As the exhaust heats up, the optimum HP RPM increases. A multi-angle cam reduces to a shallower (smaller) angle as the clutch shift out and the RPM is increased to match the **hot** HP curve of the engine. This phenomena is more pronounced on engines with narrower powerbands.

Oval and snowcross racers need the best of both worlds. A good holeshoot is critical but backshifting must be quick in order to have good response out of the corners. They may have to change cam angles depending on what type of track layout is encountered.

Driven pulley cams are helices. A helix is measured in lead. Lead is the distance a point moves along the axis of rotation in one revolution of the helix. (Screw threads are a helix).

The helix angle is computed from the lead and the circumference of the helix.

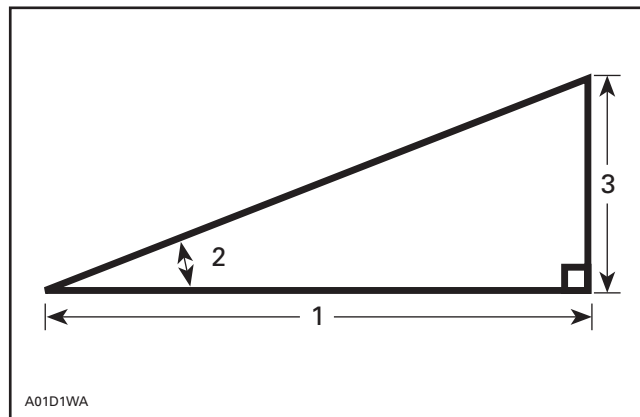

1. Circumference (C)
2. Helix angle A
3. Lead (L)

DRIVEN CLUTCH CAMS

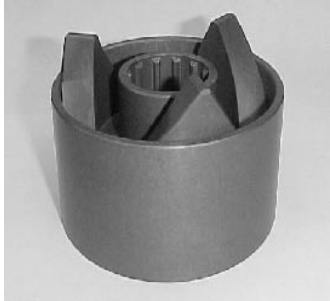
|  | |  | | |  | | |
|---|-------|--|------|-------------|---|------|-------------|
| FORMULA - STD | | FORMULA RER & VSA | | | HPV 27 & VSA | | |
| PART NUMBER | ANGLE | PART NUMBER | TYPE | ANGLE | PART NUMBER | TYPE | ANGLE |
| 860 424 800 | 40 | 417 126 715 | RER | 44 Alu. | 417 126 445 | VSA | 44 Anod. |
| 860 424 900 | 42 | 417 126 683 | RER | 47 Alu. | 417 126 577 | VSA | 47 Anod. |
| 860 425 000 | 44 | 417 126 716 | RER | 50 Alu. | 417 126 724 | VSA | 47-40 Anod. |
| 860 425 100 | 47 | 417 126 685 | RER | 48-44 Alu. | 417 126 385 | VSA | 47-44 Anod. |
| 860 425 200 | 50 | 417 126 680 | RER | 50-47 Alu. | 417 126 721 | VSA | 50-40 Anod. |
| 860 425 300 | 53 | 417 126 747 | RER | 44 Anod. | 417 126 580 | VSA | 50-47 Anod. |
| 860 427 600 | 56-50 | 417 126 748 | RER | 47 Anod. | | | |
| 860 427 500 | 56-47 | 417 126 749 | RER | 50 Anod. | 417 126 740 | 27 | 53-50 Anod. |
| 860 427 400 | 56-44 | 417 126 750 | RER | 48-44 Anod. | 417 126 741 | 27 | 53-47 Anod. |
| 860 427 300 | 53-50 | 417 126 751 | RER | 50-47 Anod. | 417 126 722 | 27 | 50-40 |
| 860 427 200 | 53-47 | | | | 417 126 725 | 27 | 47-40 |
| 860 427 100 | 53-44 | 417 126 718 | VSA | 44 Anod. | 417 126 674 | 27 | 44-40 |
| 860 427 000 | 53-42 | 417 126 707 | VSA | 47 Anod. | 417 126 742 | 27 | 40-44 |
| 860 426 900 | 53-40 | 417 126 719 | VSA | 48-44 Anod. | 417 126 743 | 27 | 44-47 |
| 860 426 800 | 50-47 | 417 126 704 | VSA | 50 Anod. | 417 126 744 | 27 | 47-50 |
| 860 426 700 | 50-44 | 417 126 720 | VSA | 50-47 Anod. | | | |
| 860 426 600 | 50-42 | | | | | | |
| 860 426 500 | 50-40 | | | | | | |
| 860 426 400 | 50-37 | | | | | | |
| 860 426 300 | 47-44 | | | | | | |
| 860 426 200 | 47-42 | | | | | | |
| 860 426 100 | 47-40 | | | | | | |
| 860 426 000 | 47-37 | | | | | | |

SECTION 05 - DRIVE SYSTEM

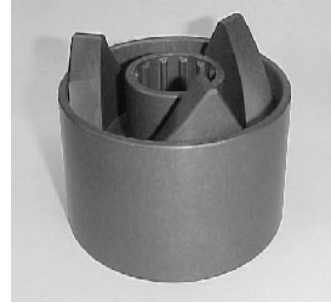

FORMULA - STD

FORMULA RER & VSA

HPV 27 & VSA

| FORMULA - STD | | FORMULA RER & VSA | | | HPV 27 & VSA | | |
|---|-------|---|------|-------|--|------|-------|
| PART NUMBER | ANGLE | PART NUMBER | TYPE | ANGLE | PART NUMBER | TYPE | ANGLE |
| 860 425 900 | 44-40 | | | | | | |
| 860 425 800 | 44-37 | | | | | | |
| 860 425 600 | 42-37 | | | | | | |
| 860 425 500 | 40-44 | | | | | | |
| 860 425 400 | 40-37 | | | | | | |
| <p>All cams have been anodized coated. The standard Formula cam can be used in place of a Formula RER or VSA cam, providing the reverse function has been disabled.</p> | | <p>The Formula RER and VSA cams are interchangeable. The difference between the two types is the number of holes drilled for spring tension and bearing surface. RER and VSA cams may be used in place of standard Formula cams also.</p> | | | <p>The HPV 27 and VSA cams are interchangeable. The difference between the two types is the number of holes drilled for spring tension adjustment. These cams are not interchangeable with Formula style cams.</p> | | |

Alu.: Aluminum
Anod.: Anodized

DRIVEN PULLEY

FORMULA VSA

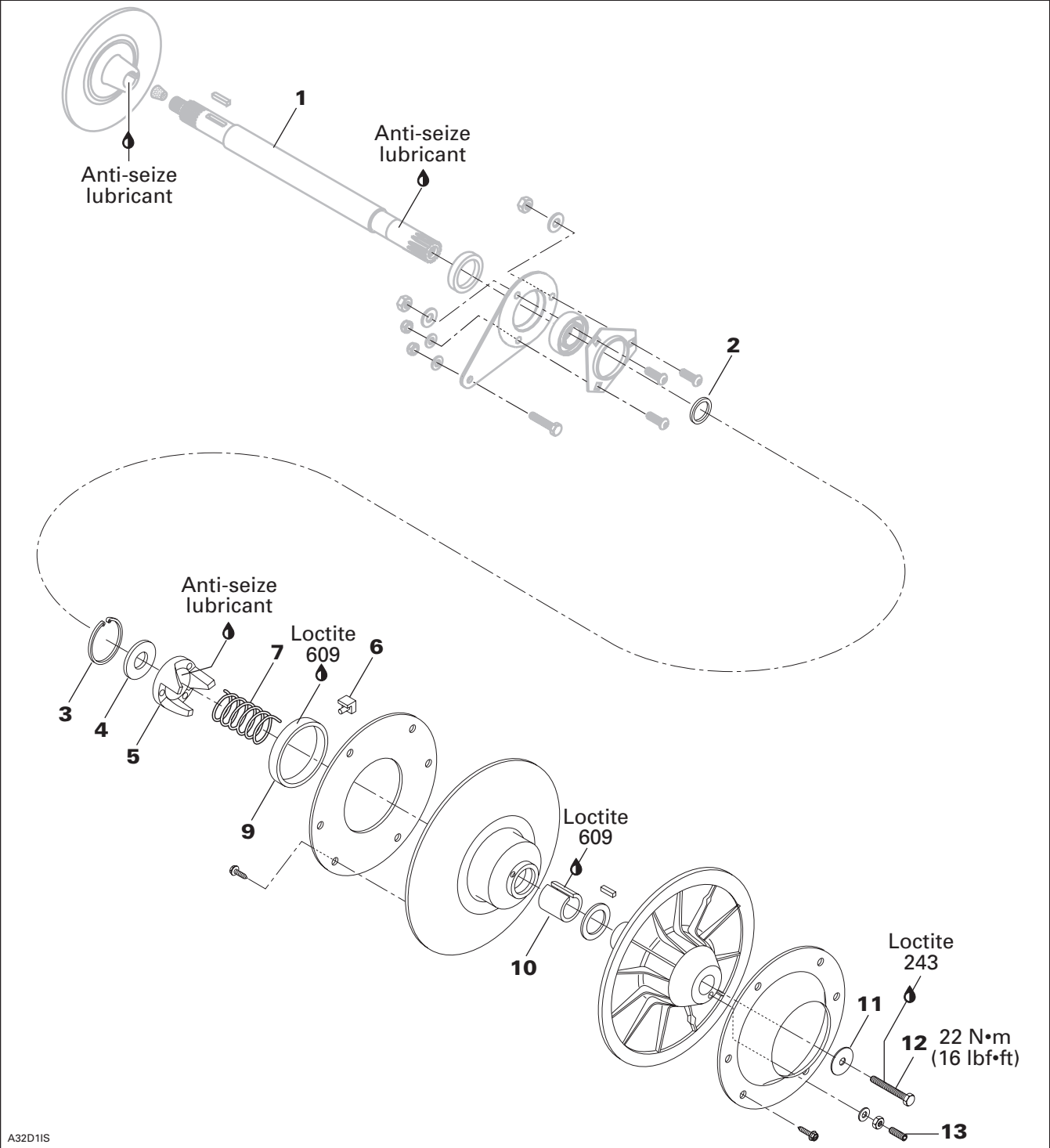

SECTION 05 - DRIVE SYSTEM

REMOVAL

Remove guard and drive belt from vehicle.

Remove cap screw **no. 12** and shouldered washer **no. 11** then pull the driven pulley from the countershaft.

Note shouldered washer position for reinstallation.

Take care not to lose spacer **no. 2**.

NOTE: Make sure that the smaller diameter spacer is against the bearing to avoid damage to the bearing seal.

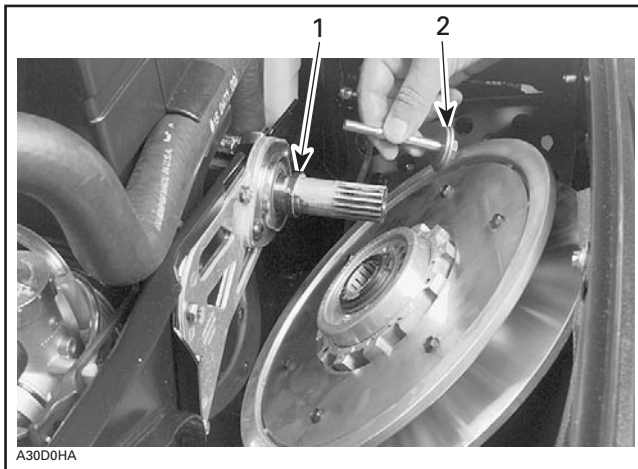

TYPICAL

1. Spacer
2. Shoulder on this side

1, Countershaft

Should countershaft **no. 1** removal be required, refer to BRAKE then look for COUNTERSHAFT AND BRAKE DISC REMOVAL.

DISASSEMBLY

Use spring compressor (P/N 529 018 600).



Remove snap ring **no. 3** and washer **no. 4** to disassemble the cam and the 2 pulley halves.

⚠ WARNING

Driven pulley cam is spring and/or torsion loaded, use above mentioned tool.

CLEANING

9, Large Bushing

During break-in period (about 10 hours of use), bushing teflon moves toward cam or shaft surface. A teflon over teflon running condition occurs, leading to low friction. So it is normal to see gray teflon deposit on cam or shaft. Do not remove that deposit, it is not dust.

When a dust deposit has to be removed from the cam or the shaft, use dry cloth to avoid removing transferred teflon.

Pulley Half Cleaning

Use Pulley Flange Cleaner (P/N 413 711 809).

INSPECTION

9,10, Bushings

Check for cracks, scratch and for free movement when assembled to fixed half.

Using a dial bore gauge measure bushing diameter. Measuring point must be at least 5 mm (1/4 in) from bushing edge.



Replace bushing(s) if worn more than specified.

| DRIVEN PULLEY BUSHING WEAR LIMIT mm (in) | |
|---|---------------|
| Large bushing | 89.15 (3.510) |

6, Slider Shoe

Check cam slider shoes for wear. Replace when inside edge thickness of cam slider shoe slope base is worn to 1 mm (.039 in) or less.

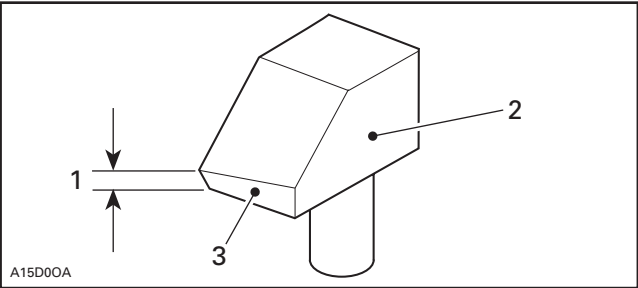

1. Measure thickness of slope base here
2. Sliding pulley side
3. Slope base

ASSEMBLY

6, Cam Slider Shoe

When replacing slider shoes, always install a new set (3 shoes) to maintain equal pressure on the cam.

Assemble driven pulley components by reversing the disassembly procedure.

5, Cam

Coat cam interior with anti-seize lubricant.

INSTALLATION

1, Countershaft

CAUTION: Always apply anti-seize lubricant (P/N 293 800 070) on the countershaft before final pulley installation.

Should installation procedure be required, refer to BRAKE then look for BRAKE DISC AND COUNTERSHAFT BEARING ADJUSTMENT.

Reinstall the pulley on the countershaft by reversing the removal procedure.

Driven pulley end-play is 0 (zero).

12, Pulley Retaining Screw

Torque to 22 N•m (16 lbf•ft).

ADJUSTMENT

7, Spring

General

It is usual to experience spring setting during breaking period of a new spring. The factory spring preload is slightly higher (about 1 kg (2 lb)) to compensate for spring setting. Specifications in TECHNICAL DATA are applicable after break-in period (about 10 hours of use).

Spring Torsional Pre-Load

To check spring pre-load adjustment, use spring scale hook (P/N 529 006 500) and a spring scale.

Remove drive belt.

Install the hook on the sliding half. Preventing fixed half from turning, pull sliding half with the spring scale perpendicularly with pulley axle.

SECTION 05 - DRIVE SYSTEM

Take 1st measurement when sliding half begins to turn. Rotate sliding half to 10 mm (3/8 in) of rotation. Hold spring scale at this position. Slowly release tension from spring scale and take 2nd measurement when sliding half begins to return. Spring pre-load is the average measurement between these 2.

$$\frac{1^{\text{st}} \text{ measurement (when opening)} + 2^{\text{nd}} \text{ measurement (when closing)}}{2} = \text{Spring pre-load}$$

Example: $\frac{3.8 \text{ kg (8.4 lb)} + 3.4 \text{ kg (7.5 lb)}}{2} = 3.6 \text{ kg (8 lb)}$ Actual spring pre-load

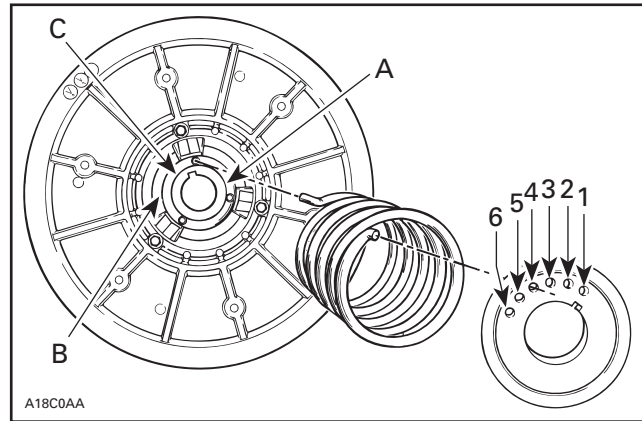

TYPICAL

Letters and numbers shown in illustration are actual letters and numbers embossed on parts

NOTE: Always recheck torsional pre-load after adjusting.

Pulley Alignment and Drive Belt Height

Refer to PULLEY DISTANCE AND ALIGNMENT and DRIVE BELT to perform adjustments.

Drive belt height is adjusted by turning Allen screws no. 13 equally and accordingly.

CAUTION: Drive belt and pulley adjustments must always be checked whenever pulleys have been removed, replaced or disassembled.

5, Cam

Make sure to install proper cam. Refer to TECHNICAL DATA.

Cam angle is identified on cam.

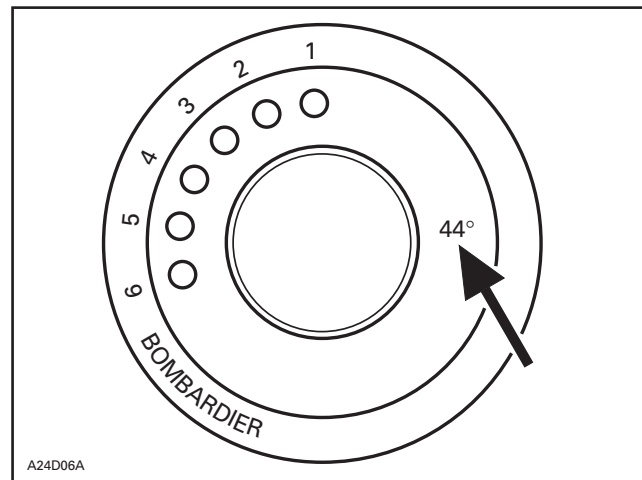

NOTE: For high altitude regions, a service bulletin will give information about calibration according to altitude.

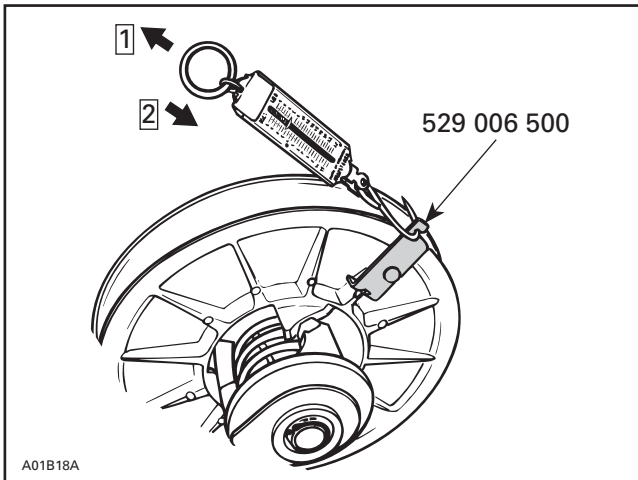

TYPICAL

Step 1: 1st measurement

Step 2: 2nd measurement

To adjust spring pre-load, relocate spring end in cam, moving it clockwise to increase the pre-load and counterclockwise to decrease it. Refer to TECHNICAL DATA.

NOTE: If spring pre-load can not be adjusted, try to relocate the other end of spring in sliding pulley (holes A, B and C).

HPV27 VSA

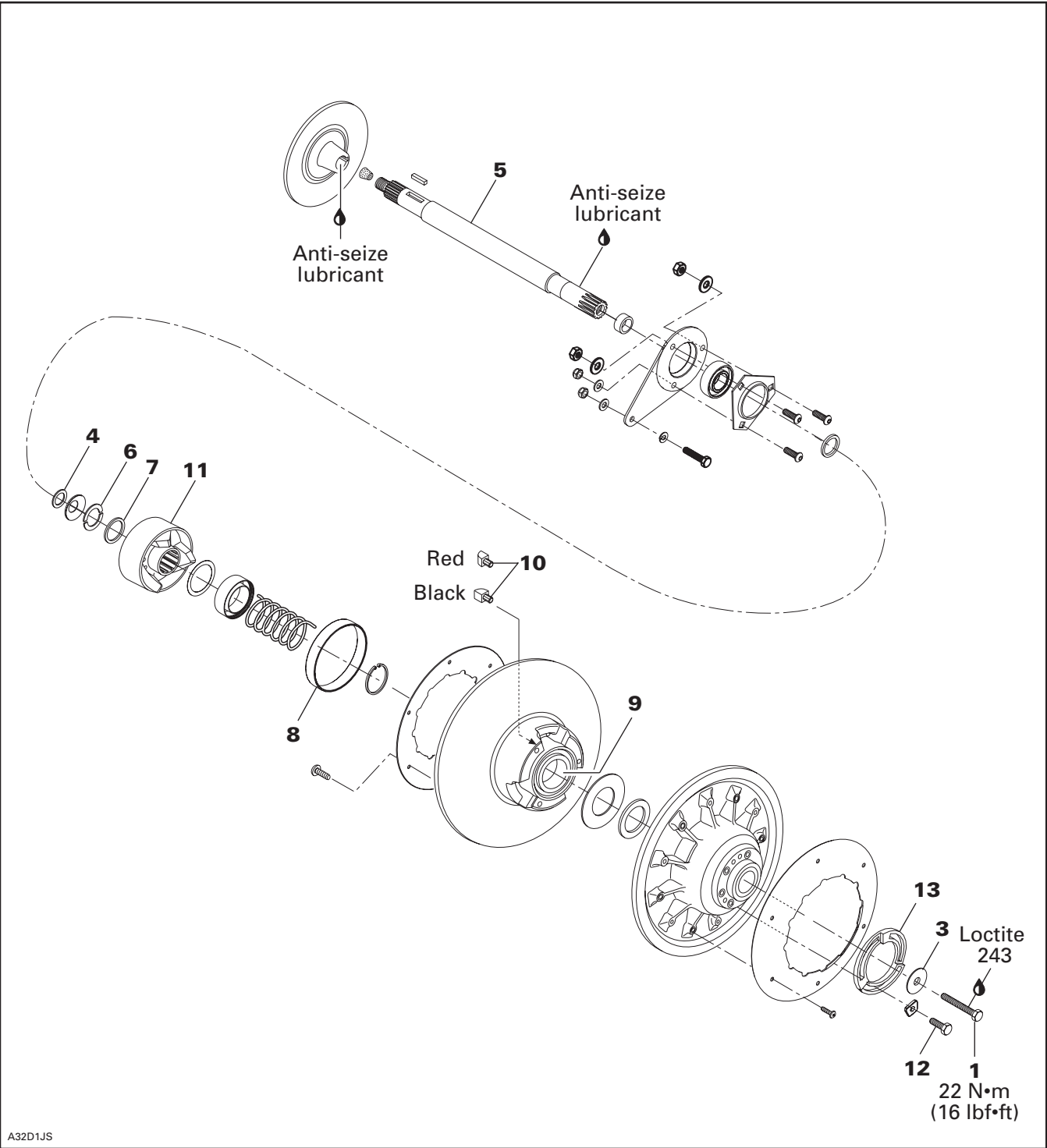

SECTION 05 - DRIVE SYSTEM

REMOVAL

Remove guard and drive belt from vehicle.

Remove cap screw **no. 1** and shouldered washer **no. 13** then pull the driven pulley from the countershaft.

Note shouldered washer position for reinstallation.

Take care not to lose spacer **no. 4**.

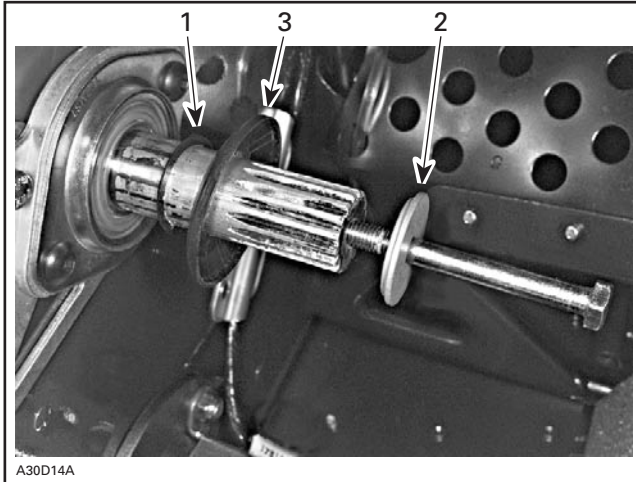

1. Spacer
2. Shoulder on this side
3. Concave side facing driven pulley

5, Countershaft

Should countershaft **no. 5** removal be required, refer to BRAKE then look for COUNTERSHAFT AND BRAKE DISC REMOVAL.

DISASSEMBLY

Use spring compressor (P/N 529 035 524).

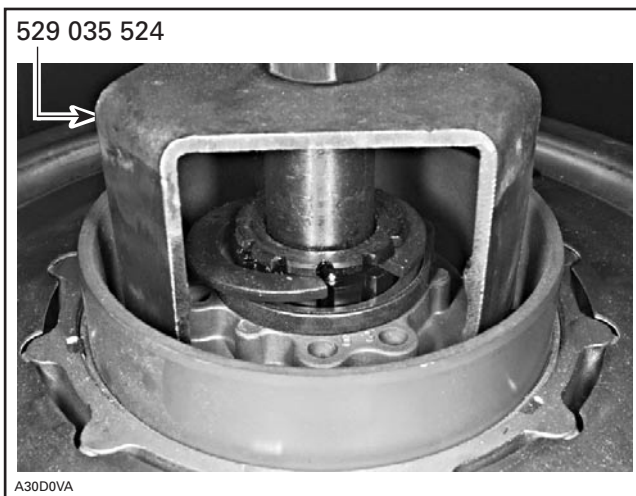

Remove half keys **no. 6** and washer **no. 7** to disassemble the cam and the 2 pulley halves.

⚠ WARNING

Driven pulley cam is spring loaded, use above mentioned tool.

CLEANING

8,9, Large Bushing and Small Bushing

During break-in period (about 10 hours of use), teflon from bushing moves to cam or shaft surface. A teflon over teflon running condition occurs, leading to low friction. So it is normal to see gray teflon deposit on cam or shaft. Do not remove that deposit, it is not dust.

When a dust deposit has to be removed from the cam or the shaft, use dry cloth to avoid removing transferred teflon.

Pulley Half Cleaning

Use pulley flange cleaner (P/N 413 711 809).

INSPECTION

10, Slider Shoe

Check cam slider shoes for wear. Replace when inside edge thickness of cam slider shoe slope base is worn to 1 mm (.039 in) or less.

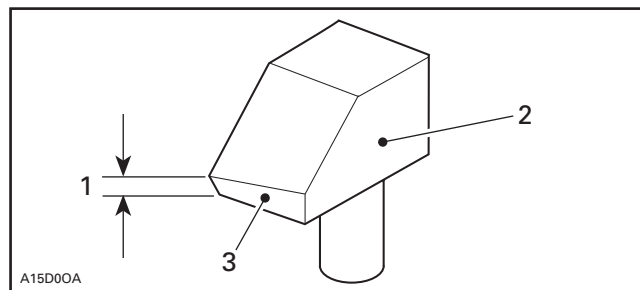

1. Measure thickness of slope base here
2. Sliding pulley side
3. Slope base

ASSEMBLY

10, Cam Slider Shoe

When replacing slider shoes, always install a new set (3 shoes) to maintain equal pressure on the cam. Install slider shoes as per following photo. RED slider shoes are being used for reverse and BLACK ones for forward.

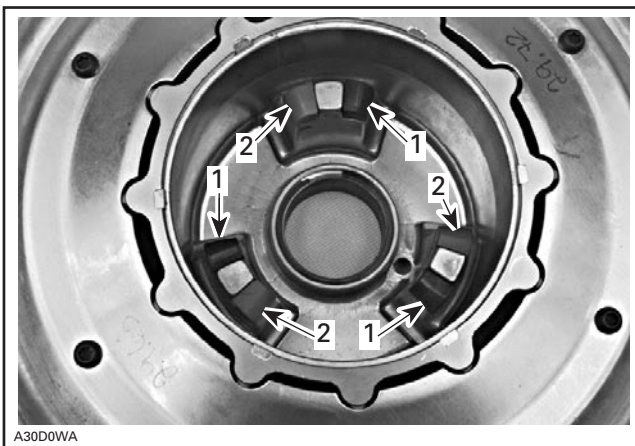

1. BLACK slider shoe
2. RED slider shoe

12, Screws

These screws are machined at there end. With the adjustment ring steel to position 0 (zero), screw ends are flush with inner side of fixed pulley half when tighten.

CAUTION: If any of these screws is not flush with inner side of sliding pulley, bushings will worn unequally.

Assemble driven pulley components by reversing the disassembly procedure.

11, Cam

Coat cam interior with anti-seize lubricant.

INSTALLATION

5, Countershaft

CAUTION: Always apply anti-seize lubricant (P/N 293 800 070) on the countershaft before final pulley installation.

Should installation procedure be required, refer to BRAKE then look for BRAKE DISC and COUNTER-SHAFT BEARING ADJUSTMENT.

Reinstall the pulley on the countershaft by reversing the removal procedure.

Driven pulley end-play is 0 (zero).

1, Pulley Retaining Screw

Torque to 22 N•m (16 lbf•ft).

ADJUSTMENT

Pulley Alignment and Drive Belt Height

Refer to PULLEY DISTANCE AND ALIGNMENT and DRIVE BELT to perform adjustments.

Loosen screws no. 12, turn adjustment ring no. 13 then retighten screws to adjust drive belt height.

CAUTION: Drive belt and pulley adjustments must always be checked whenever pulleys have been removed, replaced or disassembled.

11, Cam

Make sure to install proper cam. Refer to TECHNICAL DATA.

Cam angle is identified on cam.

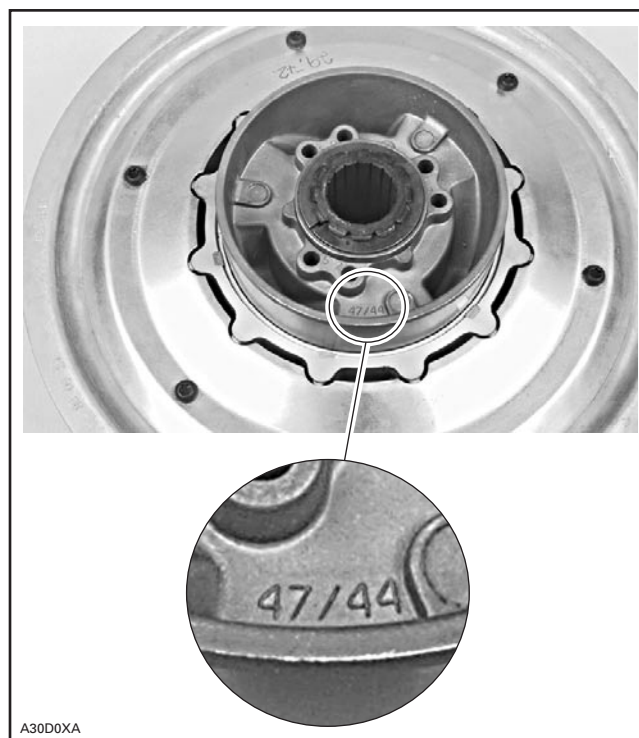

NOTE: For high altitude regions, a service bulletin will give information about calibration according to altitude.

SECTION 05 - DRIVE SYSTEM

TEAM PERFORMANCE DRIVEN CLUTCH

(All TEAM Performance Clutch Parts must be ordered from the Valcourt Race Dept. or Ski Doo Parts Support Truck)

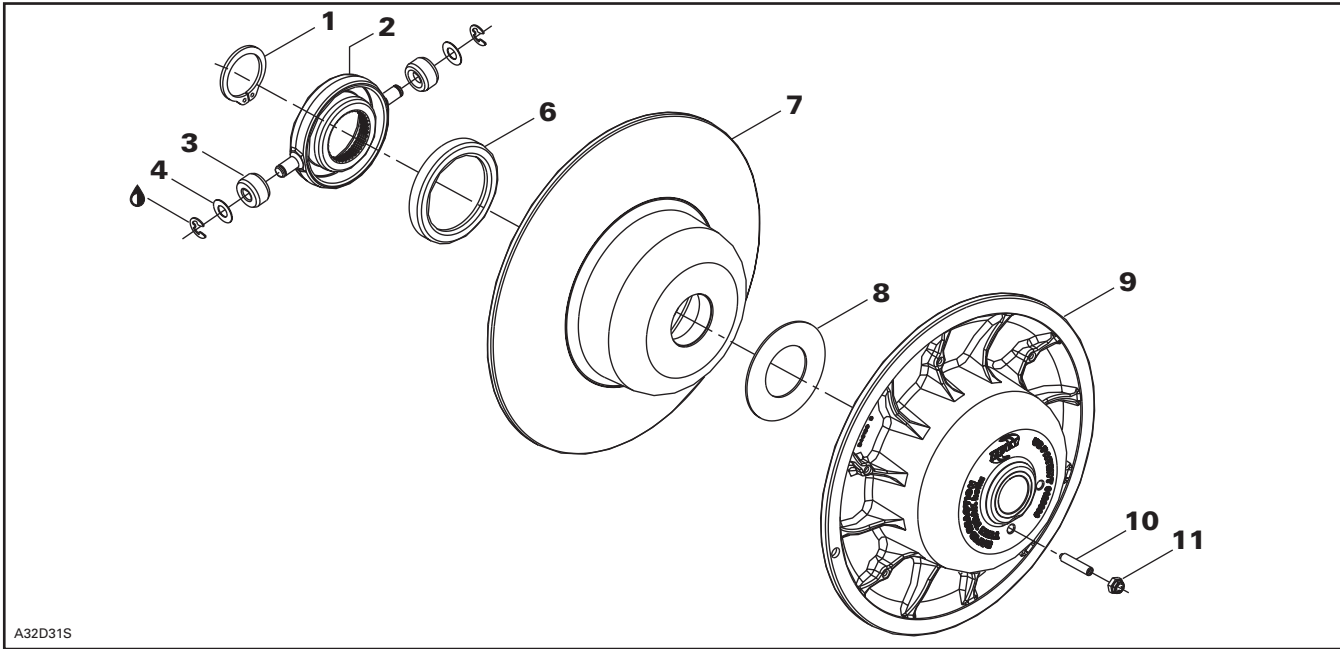

| ITEM NO. | PART NUMBER | QUANTITY | DESCRIPTION | SERVICEABLE |
|----------|-------------|----------|----------------------------------|--------------|
| 1 | 130032 | 1 | Ring, Retaining Basic Ext. 1.500 | Yes |
| 2 | 285275 | 1 | Spider, 38T 10.75 Mach. | No |
| 3 | 460079 | 2 | Roller, Clutch | Yes |
| 4 | 150151 | 2 | Washer, Thrust | Yes |
| 5 | 130059 | 2 | Ring, Retaining E-Ring Ext. .375 | Yes |
| 6 | 430063 | 1 | Washer, Thrust | Yes |
| 7 | 410488 | 1 | Subassembly Moveable Sheave | Bushing Only |
| 8 | 150175 | 1 | Spacer | Yes |
| 9 | 410489 | 1 | Subassembly Stationary Sheave | No |
| 10 | 105100 | 1 | Screw, Set Hex SKT ¼-20 x 1.25 | Yes |
| 11 | 110003 | 1 | Nut, ¼-20 UNC Flexlock | Yes |

SECTION 05 - DRIVE SYSTEM

The two pictures shown below are showing how the helix angles are called out and how they are measured. The first picture shown is a full progressive stamped as "F" on a helix (example 54-40- F). The second picture refers to a partial or .46 as most of our helix's are called out (example 58-44.46). During the transition zone the angle is constantly changing.

The angle will remain constant once the shift pattern passes through the transition zone.

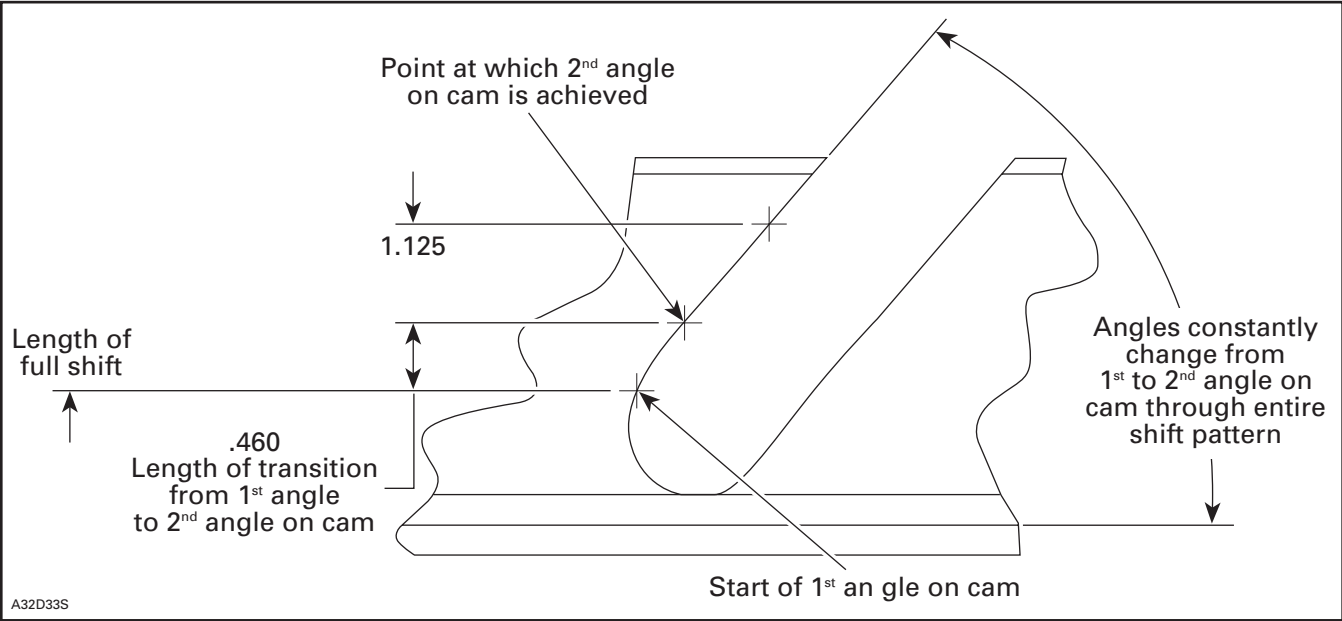
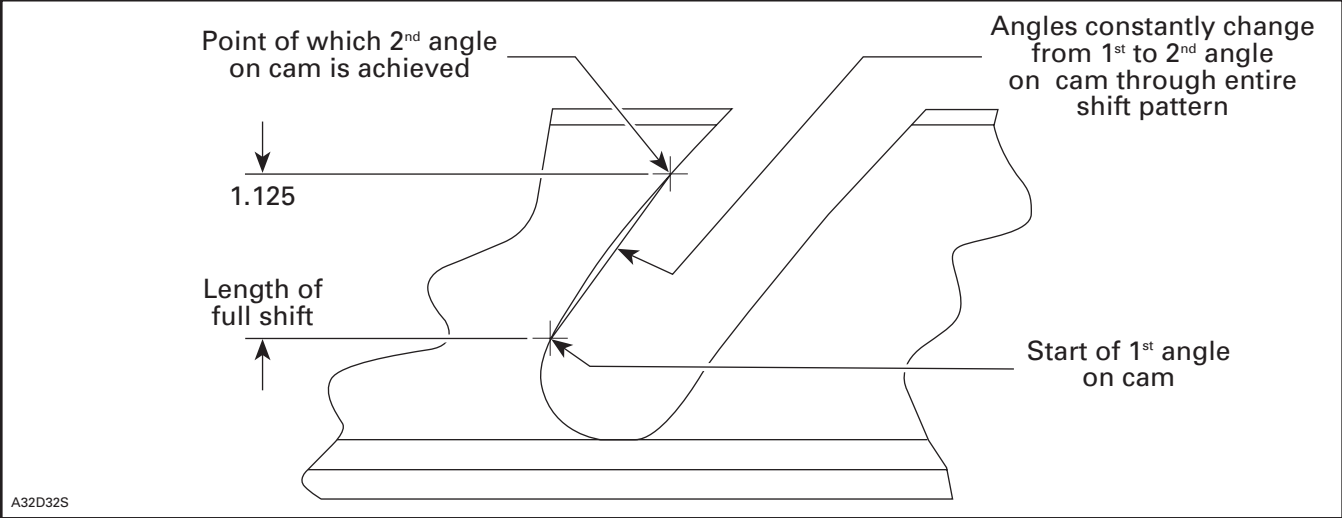

SECTION 05 - DRIVE SYSTEM

SPRINGS

The springs used in the TEAM Performance Driven Clutch are measured differently because of the use of a compression spring instead of a torsion spring. The first number on our spring which is measured at 2.2" is the starting rate where the secondary will begin to open. The second measurement of 1.1" is the final compression achieved at full shift.

Examples: 140-200 spring vs. 100-200 (The 140-200 spring has a higher starting compression than 100-200 spring, better throttle response than the 100-200, same ending compression meaning the overall RPM's should run the same with 100-200 spring.)

The higher you go with the ending compression load, the higher your RPM's will be. For every 20 lbs. of spring added to the final compression load you will have to go up two degrees in helix angle. If you take away 20 lbs. of ending compression you will have to go down two degrees in helix angle.

It is not recommended to shim any springs to achieve extra RPM's. If the sled you are tuning is low on RPM's, weight should be removed from the primary clutch or helix angle should be dropped to achieve correct and consistent RPM's.

Improper springs, drive clutch ramp, weight or helix combination can result in excessive clutch heat. If the helix is matched properly with the spring, drive clutch ramp and weight combination, the result should be a fast, efficient, cool running clutch setup.

Relationship Between Drive Clutch Ramps, Weight, And Spring In Maintaining Operating RPM

The drive clutch is a RPM sensing unit designed to transfer the maximum amount of horsepower from the engine to the ground. This is accomplished by ramps, weight and a spring inside the unit which react to the centrifugal force from the engine RPM. The spring, ramps and weight work in combination. In a properly set up clutch, the maximum desired operating RPM will be reached immediately after clutch engagement, under full throttle conditions. To gain optimum power this RPM should be maintained. As centrifugal force pushes the weight against the ramps, the movable sheave will force the belt to climb up the drive clutch sheave and increase vehicle speed. If the weight is too light, the ramp too steep, or the spring rate too high, the engine will over rev and the clutches won't be able to shift all the way out. If the weight is too heavy, the ramp too shallow or the spring is too light, the engine RPM will be low. The result of either condition will be dramatic loss of horsepower and torque.

ADJUSTING BELT DEFLECTION ON THE TEAM ROLLER SECONDARY

1. To adjust the sheaves, loosen the 7/16" jam nut on the belt width adjuster.
2. Using a 1/8" Allen wrench (PN 920001), adjust the threaded set screw as needed.

NOTE: Turn the set screw in (clockwise) to increase the distance between the sheaves and out (counter-clockwise) to decrease the distance.

3. Tighten the jam nut after the belt adjustment has been made. See arrow.

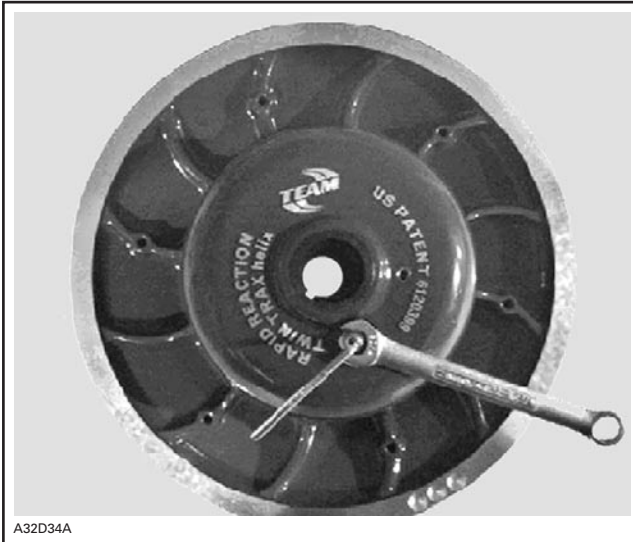

A32D34A

BELT REMOVAL ON TEAM ROLLER SECONDARY

1. Thread the belt installation tool (PN 930002) into the open hole next to the belt width adjuster bolt.
2. Thread the tool into the hole until the sheaves separate enough to remove the drive belt.

(If the tool turns hard, rotate the moveable back and forth to ensure that the roller is not locked in the ER notch.)

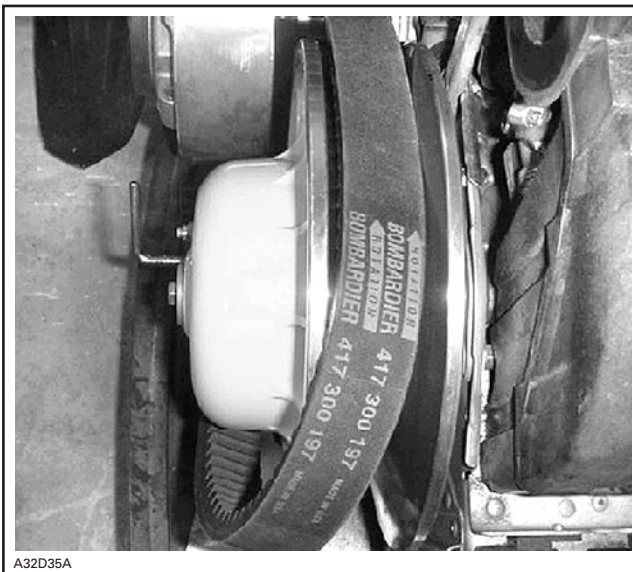

A32D35A

Too Much Belt Deflection

If the belt is too long or the center distance is too short, the initial starting ratio will be too high, resulting in performance loss. This is due to the belt rising too high in the drive clutch sheaves upon engagement. (Belt riding below top of sheave.)

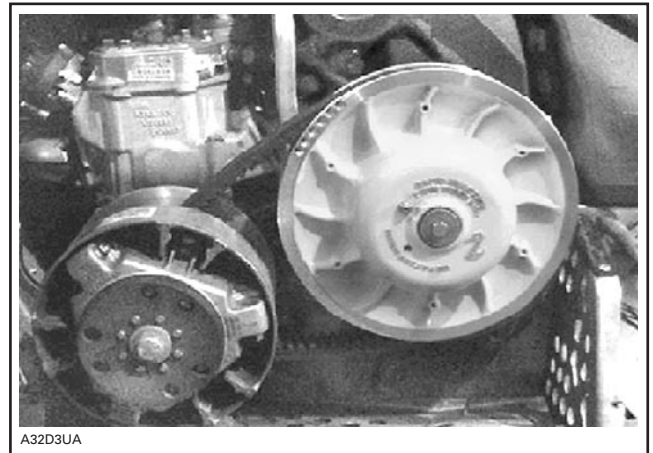

A32D3UUA

Not Enough Belt Deflection (belt too tight)

If the drive belt is too short or the center distance is too long, the ratio will again be incorrect. In addition, the machine may creep when the engine idles, causing damage to the internal face of the drive belt.

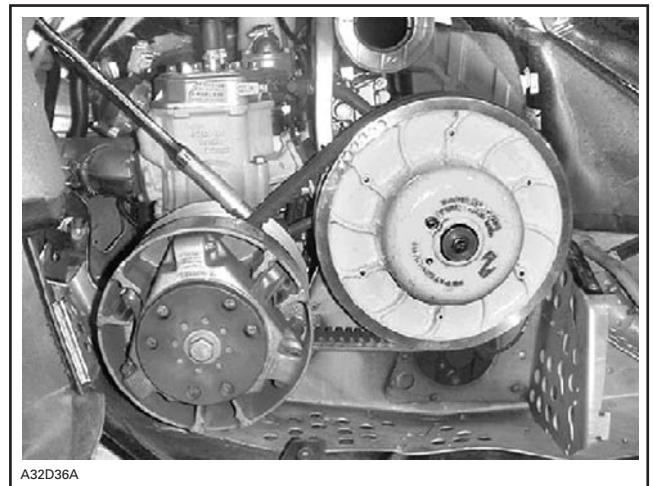

A32D36A

MEASURING BELT DEFLECTION

IMPORTANT NOTE: Do not apply excessive pressure to force belt into driven sheaves. This will result in an improper measurement. If belt deflection cannot be adjusted within specification using methods below, inspect center distance and compare to specifications.

SECTION 05 - DRIVE SYSTEM

1. Measure belt deflection with both clutches at rest and in their full neutral position.
2. Place a straight edge on the belt and apply downward pressure while measuring at the point shown.

Belt Deflection - 1-1/4 in (3.2 cm).

TEAM SECONDARY CLUTCH MAINTENANCE/ADJUSTMENT

1. Remove clutch from vehicle.
2. Remove the screws that hold the helix in place, (Torx Wrench PN 920002).
3. Pull and twist upward to remove helix from the clutch. Note: If changing helix angles move the helix 90 degrees to the desired combination and reinstall holding screws.

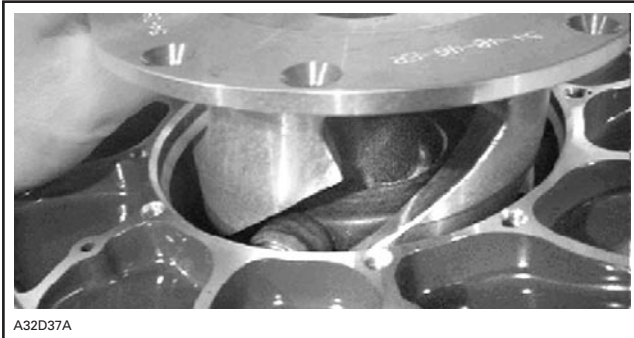

1. Place the compression tool (PN 930001) through the clutch shaft and twist handle down to compress spring.

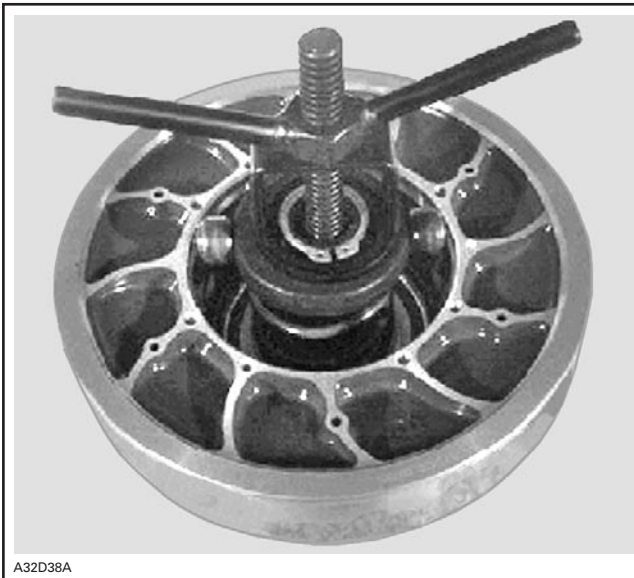

2. Once you have tension on the spider assembly, remove the snap ring.
3. Back off the compression tool and remove the spider assembly.
4. Note the location of the skip tooth on the spider assembly for installation. The skip tooth is marked with an X on the spider that should match the skip tooth found on the clutch shaft. The X should also line up with the machined dimple found on the moveable sheave.



1. Inspect spring rate at proper load heights with spring compression scale (all TPS secondary springs measured at load heights of 2.2" and 1.1"). If spring rate measures less than 10% at specified load heights it should be replaced.
2. Inspect roller assembly for unusual wear or damage (flatspots or dia. less than .925).
3. Inspect shaft for nicks or burrs.
4. Measure ID of moveable bushing, clearance to shaft should not exceed .010". If this condition exists replace bushing. Part No. 180165.
5. With air hose or clean dry rag wipe or blow all components free of all loose contaminants.

Reassemble In Reverse Order

- * Make sure that the "X" on the spider and the 1/8" dia. drilled dimple on the moveable sheave are aligned prior to installing the helix. This ensures proper balance!!!

INSTALLATION

1. Install proper number of spacer washers on jackshaft between clutch and jackshaft bearing.
2. Inspect Jackshaft Bearing
3. Excessive vibration or abnormal drive belt wear can be caused by a worn bearing or jackshaft on the driven clutch side. To inspect bearing fit, watch the bearing area closely as you try to force the jackshaft up and down. If movement is detected, disassemble to determine which parts are worn. Replace the jackshaft if the new bearing is loose on the shaft. The bearing should be greased at 1000 mile (1600km) intervals and before storage.

NOTE: Spacer washers between driven clutch and jackshaft bearing set the offset.

1. Lightly grease jackshaft keyway or spline. With square key in place slide clutch onto jackshaft.
2. Install spacer, bolt and washer to hold driven clutch in place.
3. See belt installation instructions.

TROUBLESHOOTING

1. Always make sure to use the OEM belt that is specified for your sled. Using the incorrect belt can result in RPM fluctuation. **It is very important when tuning to ensure the proper belt width, compound, and length.** This is one of the most common causes of poor performance.
2. Verify ramps, weights and spring in the drive clutch are correct first. If performance problems still exist, look to the secondary.

3. Helix angle selection. Starting angle will effect how fast the clutch opens from a dead stop. Ex. (70-44.46, a 70° starting angle will shift extremely fast). If the sled will not pull RPM until farther out in the shift pattern this angle may be too steep. The second number, (as in example 44°) will affect the shift rate from approximately 1/3 of the shift on. If there is a problem with the helix, this is normally the culprit. If your engine is over reving and the sled is not going anywhere, the angle is probably too shallow. If you can't achieve desired RPM or the sled goes flat towards top end, the angle is very likely too steep.
4. Secondary springs can also affect the RPM and shift rate. It is best to start with a lower rate spring and move up from there. Stiff springs can cure some problems and create others at the same time. Heat can be one of the biggest problems when running stiff springs. Heat will rob performance extremely fast. The lighter the spring you can run and still achieve the results you want the better. Spring rate will also affect back shifting. For most flat land applications start with a 140-200 spring, mountain setups 140-240.
5. Under racing conditions, clutches should be taken apart often and wiped clean of any foreign material. Make sure not to use any solvents or lubricants on bushings or rollers during this process. At this time it is recommended that the spring is measured for correct operating loads.
6. Alignment has a huge role on performance and belt life. Make sure to use the proper clutch alignment tool.

SECTION 05 - DRIVE SYSTEM

7. When inspecting the rest of the clutching components the primary clutch should be checked for four things:

- "Worn out rollers and bushings
- "Flat spots on ramps
- "Worn out buttons in the clutch towers
- "Worn out bushing on moveable clutch sheave and clutch cover

RPM Graph Examples

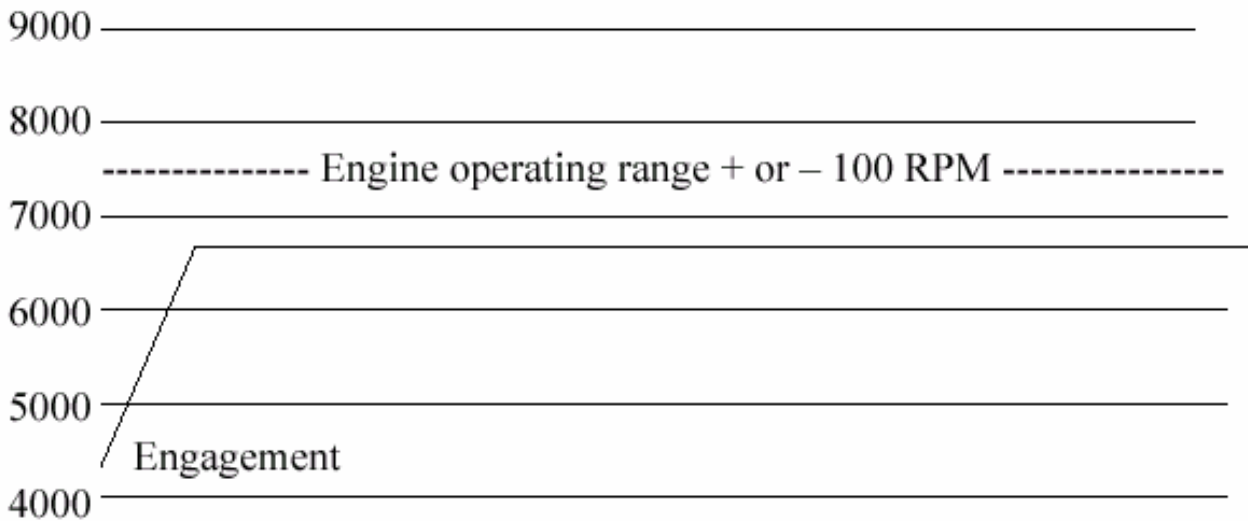

If the weights are too heavy, or spring rate too low, the engine RPM will be low and the drive clutch will up-shift too fast, keeping the engine out of its power band.

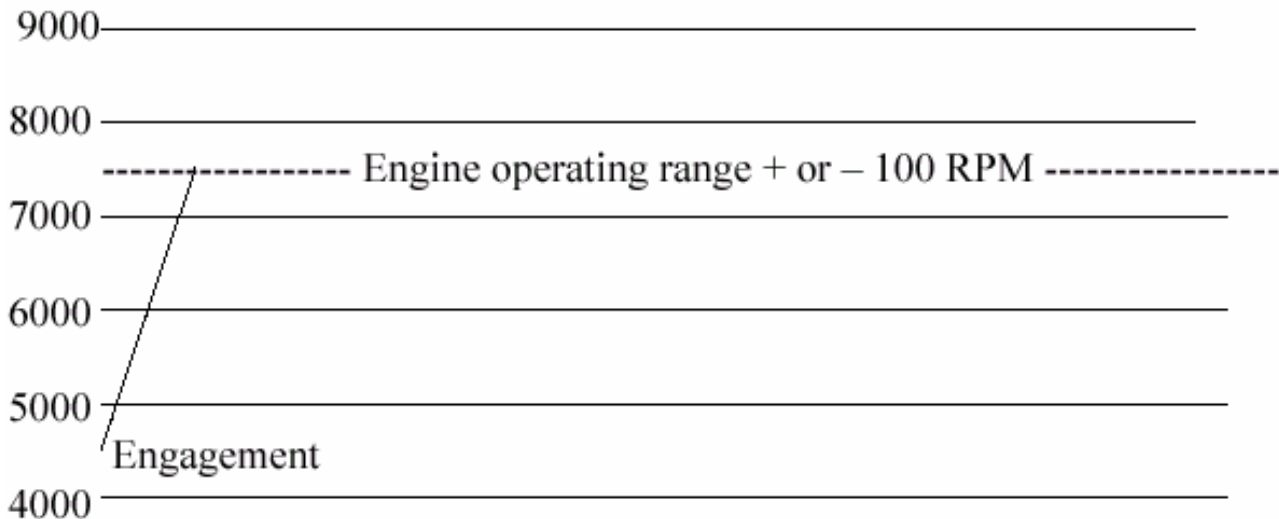

If the clutching setup is calibrated properly, the engine should hold consistent RPM's, during up-shift and back-shift.

TEAM PERFORMANCE DRIVEN CLUTCH PARTS

(All TEAM Performance Clutch Parts must be ordered from the Valcourt Race Dept. or the Ski Doo Parts Support Truck)

| SPRINGS | |
|-------------|----------|
| PART NUMBER | RATE LBS |
| 210035 | 100-150 |
| 210063 | 125-175 |
| 210064 | 140-200 |
| 210084 | 100-200 |
| 210085 | 120-220 |
| 210086 | 140-240 |
| 210095 | 140-260 |
| 210100 | 155-222 |
| 210106 | 123-203 |
| 210114 | 140-220 |
| 210134 | 160-260 |

| HELIX | |
|-------------|-----------------------|
| PART NUMBER | TWIN TRAX ANGLE |
| 420400 | 60-38-46 60-36-46 |
| 420401 | 56-40-46 56-38-46 |
| 420403 | 60-44-46 60-42-46 |
| 420404 | 66-40-46 66-38-46 |
| 420405 | 54-38-46-E 54-40-46-E |
| 420406 | 54-40-46-E 54-42-46-E |
| 420407 | 58-38-46-E 58-40-46-E |
| 420408 | 58-42-46-E 58-44-46-E |
| 420409 | 64-40-46-E 64-44-46-E |
| 420423 | 34 STRT 36 STRT |
| 420424 | 60-44-46-E |
| 420425 | 60-46-46-E |
| 420426 | 62-48-46-E |

| HELIX | |
|-------------|-----------------------|
| PART NUMBER | TWIN TRAX ANGLE |
| 420427 | 62-44-46-E |
| 420428 | 62-40-46-E |
| 420429 | 58-40-46-E |
| 420430 | 58-42-F 62-44-F |
| 420433 | 54-42-36-E |
| 420434 | 36 STRT-E 38 STRT-E |
| 420435 | 42 STRT-E 38 STRT-E |
| 420436 | 54-44-46-E 44 STRT-E |
| 420437 | 54-44-46 44 STRT |
| 420438 | 56-38-46 56-40-46 |
| 420439 | 56-38-46-E 56-40-46-E |
| 42440 | 36 STRT 38 STRT |
| 420451 | 50-42-46 50-44-46 |
| 420452 | 50-42-46-E 50-44-46-E |
| 420453 | 42 STRT 44 STRT |
| 420454 | 42 RS 44 RS |
| 420478 | 42 STR ER 44 STR ER |
| 420501 | 42-36-F 50-36-46 |
| 420504 | 48-40-F 56-40-46 |
| 420505 | 52-36-46 52-32-46 |
| 420506 | 50-36-F 56-36-46 |
| 420507 | 48-34-F 56-34-46 |
| 420508 | 46-42-F 52-42-46 |
| 420509 | 52-40-F 58-40-46 |
| 420510 | 52-36-46 50-34-46 |
| 420512 | 54-38-46 54-36-46 |
| 420513 | 49-40-46 49-38-46 |

SECTION 05 - DRIVE SYSTEM

| HELIX | |
|-------------|-----------------------|
| PART NUMBER | TWIN TRAX ANGLE |
| 420514 | 54-40-46 54-38-46 |
| 420515 | 58-40-46 58-38-46 |
| 420516 | 54-44-46 54-42-46 |
| 420517 | 58-44-46 58-42-46 |
| 420518 | 60-40-46 60-38-46 |
| 420519 | 60-48-46 58-44-46 |
| 420520 | 54-36-46 54-34-46 |
| 420524 | 66-48-46 66-40-46 |
| 420525 | 62-44-46 62-40-46 |
| 420526 | 58-44-46 58-40-46 |
| 420529 | 64-44-46 64-40-46 |
| 420530 | 58-44-46-E |
| 420531 | 46-34-F 48-34-F |
| 420532 | 64-48-46 54-44-F |
| 420533 | 66-44-56 54-42-F |
| 420535 | 54-34-46 64-42-46 |
| 420536 | 54-34-46 48-34-F |
| 420537 | 66-44-56 66-44-46 |
| 420538 | 66-44-46 66-40-46 |
| 420541 | 58-42-46-E |
| 420542 | 62-42-46-E |
| 420543 | 62-46-46-E |
| 420545 | 54-40-46 54-42-46 |
| 420546 | 58-40-46 58-42-46 |
| 420547 | 52-42-F 66-42-46 |
| 420548 | 54-40-46 64-42-46 |
| 420549 | 54-44-F 68-44-46 |
| 420554 | 52-40-46-4 52-40-46-2 |
| 420561 | 66-44-46 70-44-46 |
| 420562 | 38 STRT 42 STRT |

| HELIX | |
|-------------|-----------------|
| PART NUMBER | TWIN TRAX ANGLE |
| 420563 | 40 STRT 44 STRT |
| 420564 | 42 STRT 46 STRT |
| 420565 | 44 STRT 48 STRT |
| 420566 | 46 STRT 50 STRT |
| 420567 | 48 STRT 52 STRT |
| 420568 | 50 STRT 54 STRT |
| 420569 | 52-42-F 52-40-F |
| 420570 | 50-40-F 48-38-F |
| 420571 | 54-42-F 54-44-F |
| 420572 | 56-44-F 56-46-F |

PULLEY DISTANCE AND ALIGNMENT

GENERAL

Both pulley distance and pulley alignment must be checked out to ensure the highest efficiency of the transmission system. Furthermore, optimum drive belt operation and minimal wear will be obtained only with proper pulley alignment.

CAUTION: Before checking pulley adjustment, the rear suspension must be mounted on the vehicle and track tension/alignment must be done. Always check pulley adjustment after suspension is adjusted.

WARNING

Failure to correctly perform pulley alignment may cause the vehicle to creep forward at idle.

All Pulley Alignment Specifications Refer to:

X = Distance between straight bar and drive pulley fixed half edge, **measured between pulleys.**

Y = Distance between straight bar and drive pulley fixed half edge, **measured at the end of straight bar.**

Z = Pulley distance is not adjustable on the REV Series models.

GENERAL PROCEDURE

Remove guard, drive belt, driven pulley and air silencer.

Loosen lock nut.

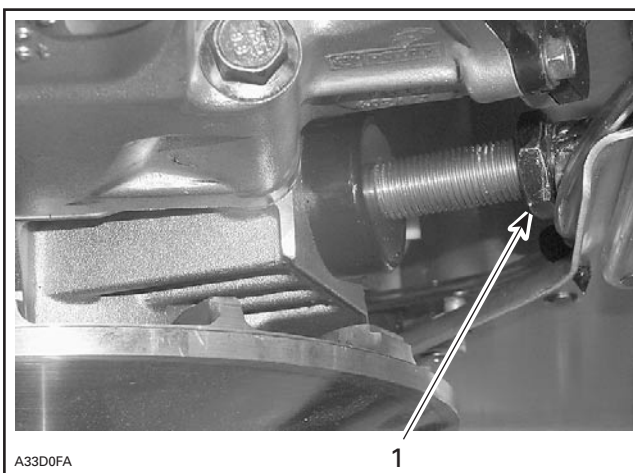

1. Lock nut

Untighten torque rod using a long hexagonal key.

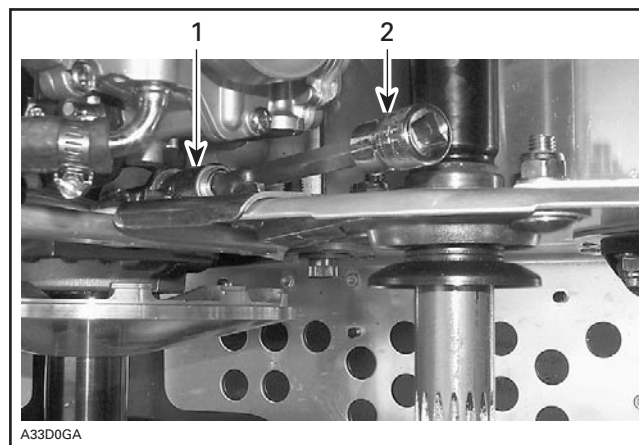

1. Torque rod
2. Hexagonal key

Install driven pulley. By using driven pulley opening tool (P/N 529 017 200) push the sliding half to open the driven pulley.

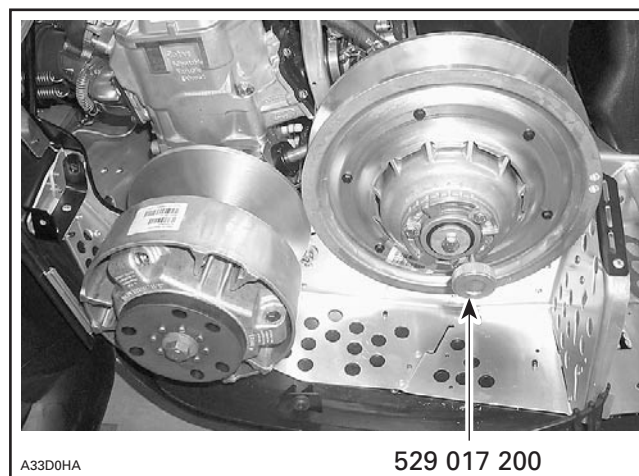

DRIVEN PULLEY OPENING TOOL

Insert a straight bar 9.5 mm (.375 in) square, 48 cm (19 in) long or the proper alignment bar into the opened driven pulley.

SECTION 05 - DRIVE SYSTEM

Measuring Procedure

Using Straight Bar

Always measure distances X and Y from the farther straight bar side (including its thickness to the fixed half edge).

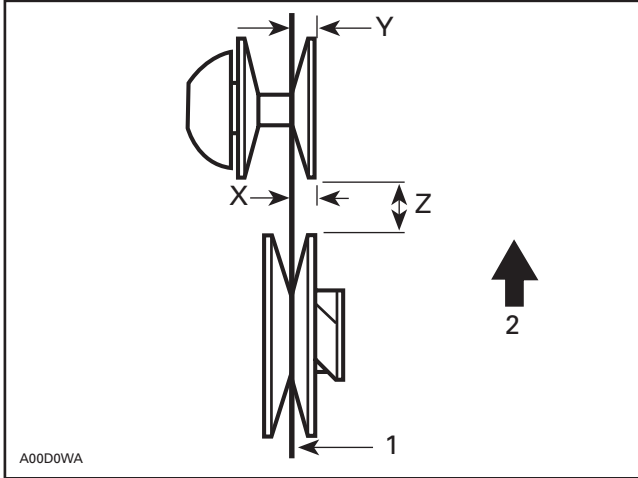

TYPICAL

1. Straight bar
2. Front of vehicle

The distance Y **must** exceed distance X to compensate for the twist due to the engine torque.

Drive Belt Deflection

NOTE: When pulley distance and alignment are adjusted to specifications, refer to DRIVE BELT to adjust drive belt deflection.

CAUTION: This section deals mainly with adjustment procedures. For complete assembly requirements, refer to the proper ENGINE or TRANSMISSION installation section.

PULLEY ALIGNMENT AND DISTANCE SPECIFICATIONS CHART

| MODEL | PULLEY DISTANCE | OFFSET | | ALIGNMENT BAR P/N |
|--|------------------------|------------------------|------------------------|-------------------|
| | Z | X | Y-X | |
| | ± 0.50 mm (.020 in) | ± 0.50 mm (.020 in) | ± 0.50 mm (.020 in) | |
| ALL REV SERIES MODELS WITH FORMULA VSA | 19.0 (0.748) | 37.0 (1.456) | 1.5 (0.060) | 529 026 700 |
| ALL REV SERIES MODELS WITH HPV 27 VSA | 20.0 (0.787) | 37.0 (1.456) | 1.5 (0.060) | 529 035 831 |
| 2004 440 REV MODELS | 20.0 (0.787) | 40.0 (?..) | 1.5 (0.060) | 529 035 831 |

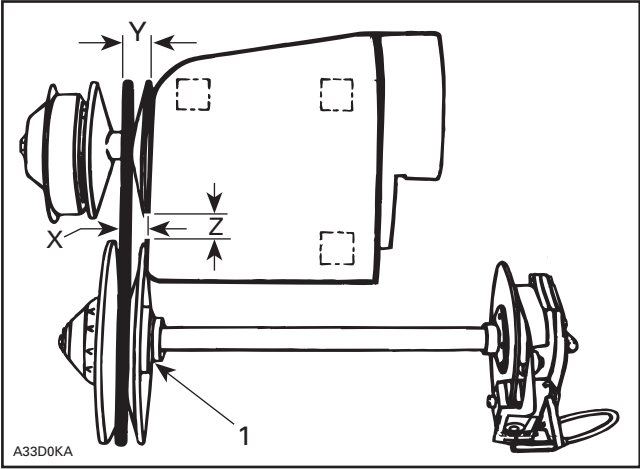

TYPICAL
1. Contact

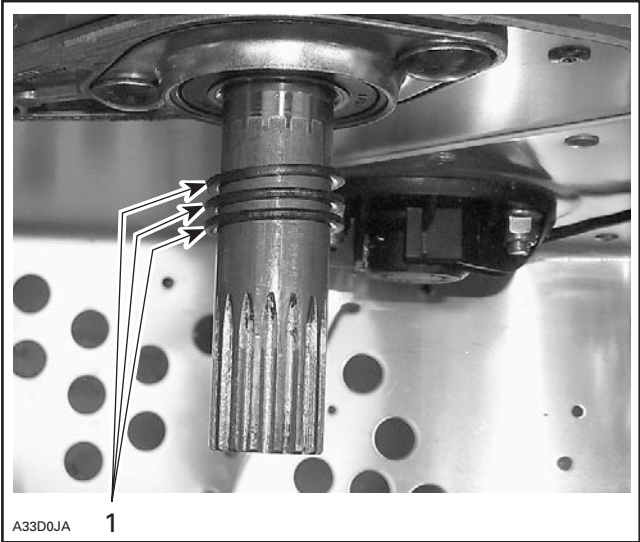

1. Spacers

NOTE: After alignment hand tighten torque rod so it slightly contacts engine crankcase. Do not over tighten, it will disalign pulleys.



ALIGNMENT BAR IN PULLEYS

NOTE: Prior to performing pulley adjustment, loosen torque rod and lock nut as mentioned above in the GENERAL PROCEDURE subsection.

Pulley Distance Adjustment Method

Pulley distance adjustment cannot be done on REV series models.

Pulley Alignment Method

Remove pulley and add or remove spacer(s) as required to obtain the specified alignment.

DRIVE BELTS

The drive belt is the critical link in transmitting power from one clutch to the other. The changes in belt technology and materials have allowed us to take for granted the kind of reliability and efficiency that not many years ago we all only dreamed about.

One of the more important changes in drive belts has been the introduction of Kevlar® Fiber B to replace fiberglass or polyester cord in the tensile layer of modern drive belts. This material is much stronger, more flexible, and allows a better adhesive bond with the various rubber compounds used to build a drive belt.

Another important change in drive belts is the increase in width. The extra width allows us to add more Kevlar cords in the tensile layer for strength with today's high output sleds.

Use only the specific Bombardier drive belt listed for your application. The drive belt is a calibrated part of the transmission system. Different belts with different compounds or angles will change how your transmission shifts.

Drive belts can vary ± 6 mm (1/4 in) length from belt to belt. Because of this manufacturing tolerance, we recommend measuring your drive belts and marking their length on the outer cover. Try to use only belts that are the same length while racing to keep your clutch set up as consistent as possible.

SECTION 05 - DRIVE SYSTEM

Always break in a new belt by running it easy for 10-15 miles. Vary the vehicle speed and throttle setting without going over $\frac{2}{3}$ throttle. It is also a good idea to mark the direction of rotation on the belt. Once the belt has been used, always run it in the same direction.

Be careful not to bend sharply or coil up these new hard compound drive belts since they are much more prone to cracking in cold weather than earlier belts.

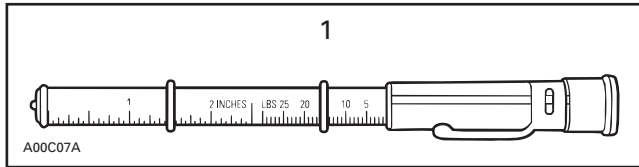

1. Use Ski-Doo tool (P/N 414 348 200)

Proper belt deflection and alignment are extremely important. Included is a page on proper alignment procedures and deflection measurement methods for your use.

Do not forget about the torque limiter rod on most models. This bolt is located between the jackshaft and the engine on the left side. It should be lightly snugged **after** the proper alignment and center to center distances have been set.

NOTE: Do not overtighten, it will misalign pulleys.

Proper deflection, setup, alignment, and break-in will help insure maximum performance and longevity from the drive belt.

DRIVE BELT

APPLICATION CHART

| MODEL | PART NUMBER | MINIMUM WIDTH (wear limit) mm (in) |
|-----------------------------------|-------------|---------------------------------------|
| 2004 440 REV | 417 300 253 | 34.70 (1.366) |
| All 593 HO engine equipped models | 417 300 197 | 33.35 (1.313) |
| All 793 HO engine equipped models | 417 300 166 | 34.70 (1.366) |
| Drag Race Belt | 417 300 230 | 34.70 (1.366) |

INSPECTION

Inspect belt for cracks, fraying or abnormal wear (uneven wear, wear on one side, missing cogs, cracked fabric). If abnormal wear is noted, probable cause could be pulley misalignment, excessive RPM with frozen track, fast starts without warm-up period, burred or rusty sheave, oil on belt or distorted spare belt.

Check drive belt width. Replace the drive belt if width is under minimum recommended width (see table above).

CHECKING NEUTRAL FUNCTION

⚠ WARNING
Always check neutral function when servicing.

Apply parking brake. Vehicle must be on the ground and on a plane level surface. No one should be in front of vehicle.

Attach vehicle tether cord to your clothing. Stand aside of vehicle, then start engine.

⚠ WARNING
Do not sit on vehicle.

Release parking brake. Vehicle must not creep when engine is idling. Otherwise, make sure that:

- idle speed is as specified
- proper belt is installed
- pulley center-to-center is as specified
- belt deflection is as specified.

ROTATION DIRECTION

The maximum drive belt life span is obtained when the drive belt is installed as shown. This will ensure that correct direction of rotation is respected.

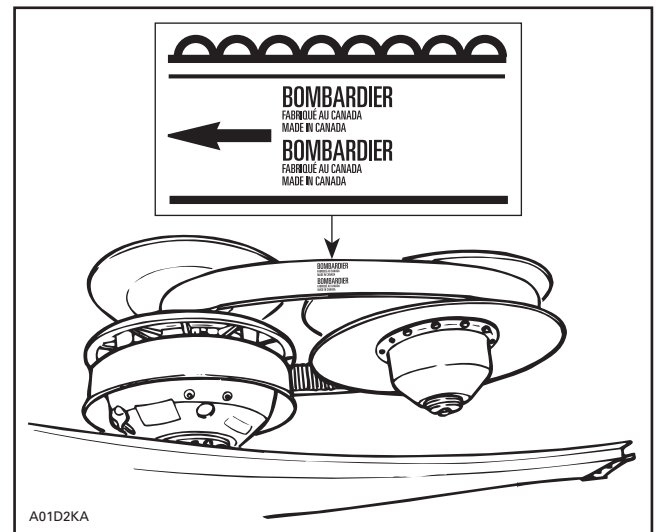

CORRECT

SECTION 05 - DRIVE SYSTEM

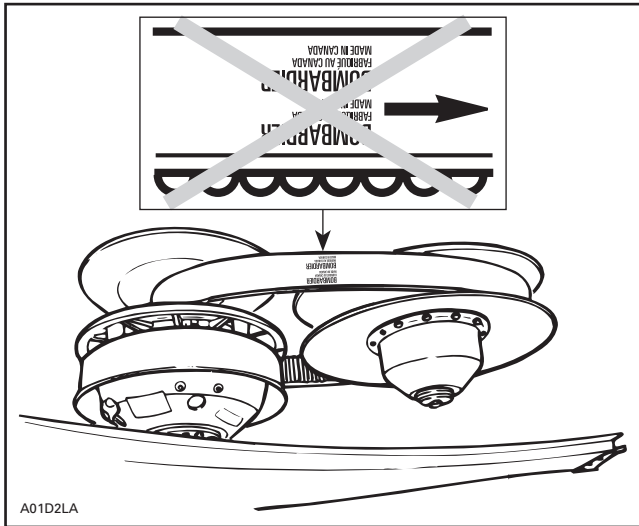

INCORRECT

NOTE: For used drive belt, mark and reinstall in the same position.

DRIVE BELT HEIGHT MEASUREMENT AND ADJUSTMENT

Measurement

NOTE: The drive belt height measurement must be performed each time a new drive belt is installed.

NOTE: To obtain an accurate drive belt height measurement, it is suggested to allow a break-in period of 50 km (30 m).

Before checking the belt height, ensure that a good-condition proper belt (refer to the *Application Chart*) is installed.

Adjust pulley distance and alignment. Refer to PULLEY DISTANCE AND ALIGNMENT.

To obtain maximum vehicle performance, the belt height must be adjusted according to specifications shown in the accompanying chart.

| MODEL | BELT HEIGHT |
|------------|---|
| All models | Top edge of drive belt cord should be flush with driven pulley edge |

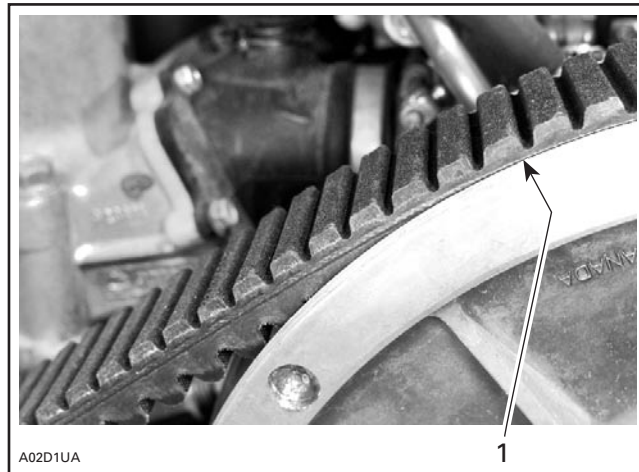

1. Flush

Adjustment

Before adjusting the belt height, ensure that a good-condition proper belt (refer to the *Application Chart*) is installed.

Adjust pulley distance according to specification, refer to PULLEY DISTANCE AND ALIGNMENT.

Models Equipped with Formula VSA Type Driven Pulley

Adjust drive belt height using Allen screws, as shown.

To lower belt in driven pulley: turn Allen screws clockwise.

To raise belt in driven pulley: turn Allen screws counterclockwise.

NOTE: Turn Allen screws 1/4 turn at a time, then rotate driven pulley to allow drive belt to settle in pulley. Check height, repeat as required.

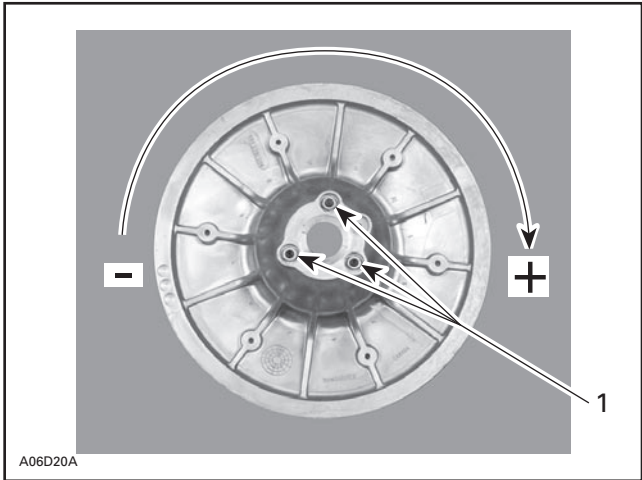

TYPICAL

- 1. Allen screws with jam nuts

Allen screws must be restrained while tightening jam nut to prevent throwing adjustment out. Use drive belt tension adjuster (P/N 529 008 700).

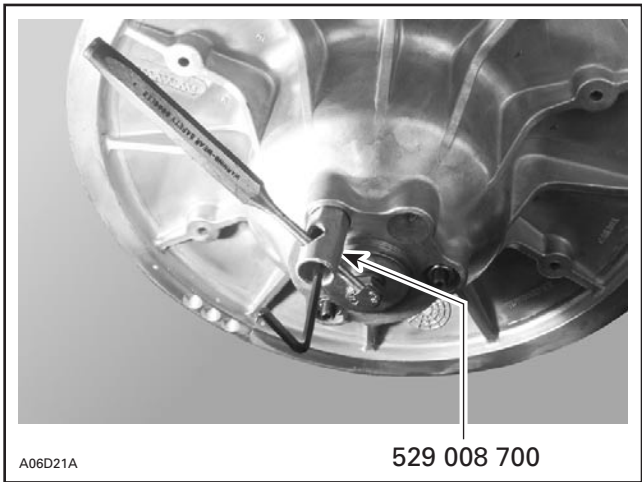

TYPICAL

Models Equipped with HPV27 VSA Type Driven Pulley

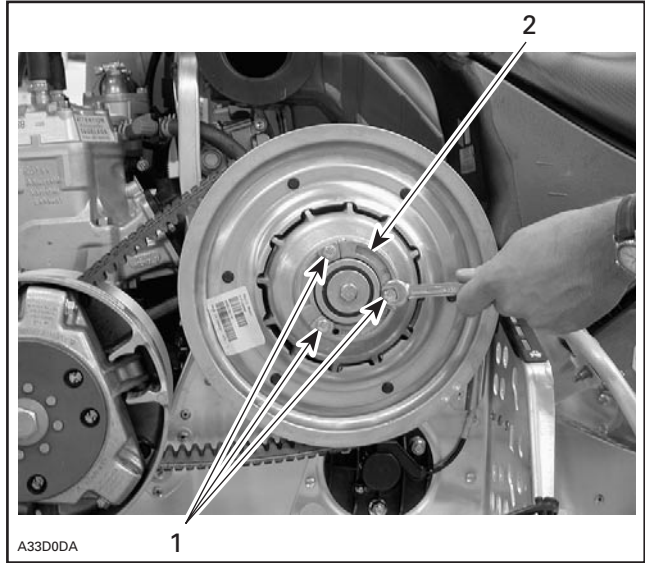

- 1. Screws
- 2. Adjustment ring

Loosen screws and turn adjustment ring as follows:

To lower belt in driven pulley: turn adjustment ring counterclockwise and tighten the screws.

To raise belt in driven pulley: turn ring clockwise and tighten the adjustment screws.

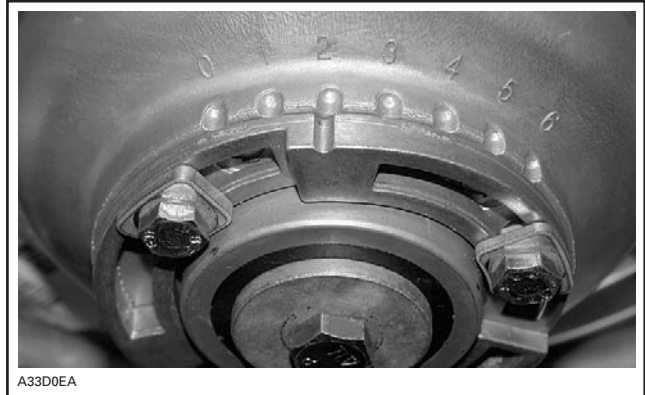

DRIVEN PULLEY NOTCHES

Turn the adjustment ring up to one notch, tighten the screws, then rotate driven pulley to allow drive belt to settle in pulley. Check height, if required the adjustment ring can be turned up to 1/4 or 1/2 the notch. Check height, repeat as required.

NOTE: Notches are there on the driven pulley for reference purpose only and the desired adjustment can be attained at any point.

SECTION 05 - DRIVE SYSTEM

DRIVE BELT DEFLECTION MEASUREMENT (reference only)

NOTE: The drive belt deflection measurement must be performed each time a new drive belt is installed.

NOTE: To obtain an accurate drive belt deflection measurement, it is suggested to allow a break-in period of 50 km (30 m).

Before checking the belt deflection, ensure vehicle has the proper belt (refer to the *Application Chart*).

Adjust pulley distance and alignment. Refer to PULLEY DISTANCE AND ALIGNMENT.

To obtain maximum vehicle performance, the belt tension must be adjusted according to specifications shown in the accompanying chart.

| MODEL | DEFLECTION [†] mm (in) | FORCE kg (lb) |
|------------|------------------------------------|------------------|
| All models | 32 ± 5 (1.260 ± .197) | 11.5 (25) |

[†] FOR REFERENCE ONLY

To Check Tension

Position a reference rule on drive belt.

Wooden Stick and Spring Scale Method

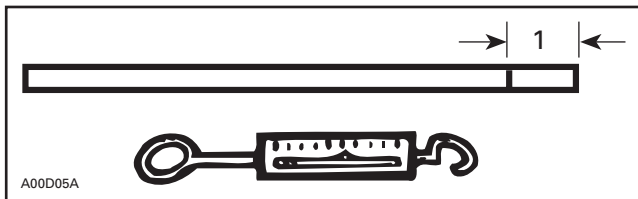

1. Mark specified deflection

Using spring scale and stick, apply specified force on drive belt halfway between pulleys as shown.

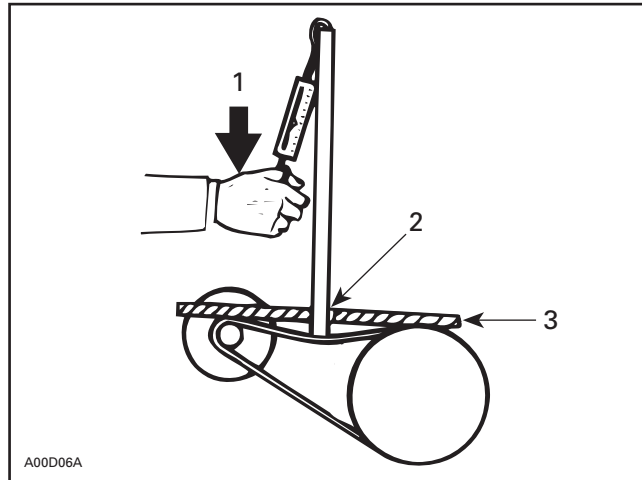

1. Force
2. Read deflection here
3. Reference rule

Or use the belt tension tester (P/N 414 348 200).

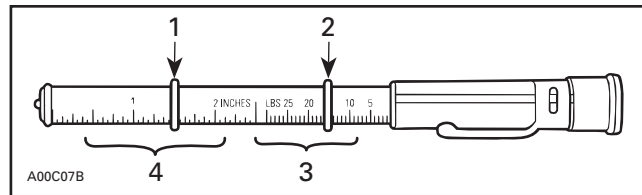

1. Lower O-ring
2. Upper O-ring
3. Force (read down)
4. Deflection (read up)

1. Slide lower O-ring of deflection scale to specified measure.
2. Slide upper O-ring to 0 (zero) on the force scale.
3. Apply pressure until lower O-ring is flush with edge of rule and read force on the upper scale at top edge of O-ring.

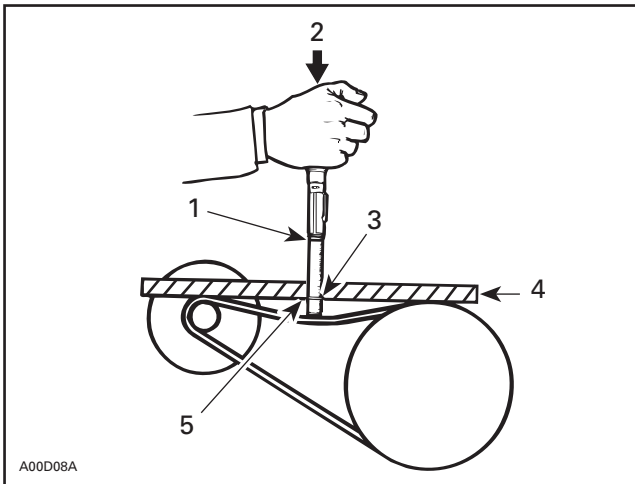

1. Upper O-ring — force
2. Force
3. Lower O-ring — deflection
4. Reference rule
5. Deflection

CHAINCASE GEARING

Contrary to popular belief, small gear changes do not directly affect top speed as long as the clutches are functioning properly. Gearing one or two teeth taller on the top will not generally make the vehicle any faster on top end unless the clutches are fully shifted out and the engine is starting to overrev.

With the TRA clutch, we have about 20 percent more shift ratio available compared to other designs. Because of this, we have been able to lower the gearing in our chaincase considerably. Yet, we still have the same overall top gear ratio because of the 0.8:1 top ratio of the TRA clutch.

This gives us better belt life by allowing our clutches to **slip** for a shorter period of time at engagement. It also provides more torque to the drive axle for acceleration.

Most snowmobiles are geared on the **high** side from the factory. They are usually geared for 8 -16 km/h (5-10 MPH) more than they would reach in average conditions. Because of this, the belt does not seem to go all the way to the top of the drive clutch. This is a normal situation. Snowmobiles run under widely varying conditions. If all snowmobiles were geared to attain a full shift under average conditions and then the vehicle were run on a perfectly smooth frozen surface, it would easily shift out to its geared top speed. Since the drag is so low under these conditions, the engine would begin to over-rev, eventually lose power, possibly damage the engine, and you will not achieve top speed.

There are other factors involved here also. As clutches shift through their range, the efficiency with which they transmit power decreases as the clutch ratio exceeds about 1.5:1. Efficiency also drops as belt speed (RPM) increases. For optimum chaincase performance ensure that you use the synthetic chaincase oil.

Because newer clutch designs shift beyond a 1:1 ratio, belt speed increases dramatically and the diameter that the belt follows around the driven pulley decreases considerably. This wastes energy and efficiency as the belt is being bent around a smaller diameter and centrifugal force is trying to pull the belt into a circular path instead of following the pulleys.

This is why for years manufacturers kept their clutch ratios around 1:1 to keep belt speeds down.

Now with the advent of larger displacement, high torque, lower RPM engines, we can use overdrive transmissions and still keep our belt speeds within reason.

As we mentioned, as belt speeds go up, efficiency drops. This is one reason many radar runners gear extremely high sometimes even approaching 1:1 in the chaincase. They have found through diligent testing that they can achieve a higher top speed without shifting their clutches all the way out because of a decrease in belt speed which means an increase in transmission efficiency. That is their bottom line.

SECTION 05 - DRIVE SYSTEM

For oval racing, the small benefit you may achieve in top end speed would probably be lost by the loss of acceleration on the start and out of the corners on a tight oval circuit.

This holds true for cross-country and snow crossers also. Top speed is not as important as quick acceleration out of the corners and ditches.

You can easily check your gearing selection by marking your drive clutch with a black marker with straight lines from bottom to top on the belt surfaces of the clutch. Go out and ride your sled under your normal conditions and stop to see how far the belt has rubbed the marker off the clutch surfaces. If it has shifted the belt all the way to the top, you may be able to pull one or two more teeth on the top sprocket. Experiment!

If it is down about 1/2 in or more from the top, you could consider trying a one tooth smaller top gear depending upon your type of racing.

The best combination of gearing for speed and acceleration you can achieve is far more important than shifting the belt **all the way to the top** of the clutches.

The following formula can be used to calculate the theoretical top speed of your Ski-Doo. The formula assumes the transmission is shifted out to its top gear ratio. Make sure you use the correct track pitch and transmission ratio for your machine.

TRA clutch top ratio = .83

Pitch of internal drive track = 2.52 in

Number of teeth on internal drive sprocket = 9

NOTE: Some Summit and long track models use 10 tooth drive sprockets.

SECTION 05 - DRIVE SYSTEM

$$\text{top speed in MPH} = \frac{\text{engine RPM}}{\text{clutch ratio}} \times \frac{\text{teeth, top sprocket}}{\text{teeth, bottom sprocket}} \times \frac{(\text{pitch of track} \times \text{No. of teeth on drive sprocket})}{12} \times \frac{60}{5280}$$

A little known fact that can seriously impair a racer's performance is the misconception that the factory stated peak horsepower RPM or the peak power point you find on a dyno is the correct figure to clutch your race sled to.

Generally, this is not the case. The figures that are printed by the factory are determined on a dynamometer in clinical test conditions.

MX Z X 440 GEAR RATIO VS SPEED

ENGINE RPM = 8500 1 - 1 RATIO

| TOP | BOTTOM | RATIO | CHAIN | MPH |
|-----|--------|-------|-------|-----|
| 27 | 43 | 1.59 | 76 | 115 |
| 26 | 43 | 1.65 | 76 | 110 |
| 25 | 43 | 1.72 | 76 | 106 |
| 24 | 43 | 1.79 | 74 | 102 |
| 23 | 43 | 1.87 | 74 | 98 |
| 22 | 43 | 1.95 | 74 | 93 |
| 21 | 43 | 2.05 | 74 | 89 |
| 20 | 43 | 2.15 | 74 | 85 |
| 19 | 43 | 2.26 | 72 | 81 |
| 27 | 44 | 1.63 | 76 | 112 |
| 26 | 44 | 1.69 | 76 | 108 |
| 25 | 44 | 1.76 | 76 | 104 |
| 24 | 44 | 1.83 | 76 | 100 |
| 23 | 44 | 1.91 | 74 | 95 |
| 22 | 44 | 2.00 | 74 | 91 |
| 21 | 44 | 2.10 | 74 | 87 |
| 20 | 44 | 2.20 | 74 | 83 |
| 19 | 44 | 2.32 | 74 | 79 |
| 27 | 45 | 1.67 | 78 | 110 |
| 26 | 45 | 1.73 | 76 | 105 |
| 25 | 45 | 1.80 | 76 | 101 |
| 24 | 45 | 1.88 | 76 | 97 |
| 23 | 45 | 1.96 | 76 | 93 |

| TOP | BOTTOM | RATIO | CHAIN | MPH |
|-----|--------|-------|-------|-----|
| 22 | 45 | 2.05 | 76 | 89 |
| 21 | 45 | 2.14 | 74 | 85 |
| 20 | 45 | 2.25 | 74 | 81 |
| 19 | 45 | 2.37 | 74 | 77 |
| 27 | 46 | 1.70 | 78 | 107 |
| 26 | 46 | 1.77 | 78 | 103 |
| 25 | 46 | 1.84 | 76 | 99 |
| 24 | 46 | 1.92 | 76 | 95 |
| 23 | 46 | 2.00 | 76 | 91 |
| 22 | 46 | 2.09 | 76 | 87 |
| 21 | 46 | 2.19 | 76 | 83 |
| 20 | 46 | 2.30 | 74 | 79 |
| 19 | 46 | 2.42 | 74 | 75 |
| 27 | 47 | 1.74 | 78 | 105 |
| 26 | 47 | 1.81 | 78 | 101 |
| 25 | 47 | 1.88 | 78 | 97 |
| 24 | 47 | 1.96 | 78 | 93 |
| 23 | 47 | 2.04 | 76 | 89 |
| 22 | 47 | 2.14 | 76 | 85 |
| 21 | 47 | 2.24 | 76 | 82 |
| 20 | 47 | 2.35 | 76 | 78 |

SECTION 05 - DRIVE SYSTEM

CHAINCASE GEARS AND CHAINS

| # OF TEETH | 13 WIDE | | |
|------------|-------------|-------------|-------------|
| | STEEL | POWDER | ALUMINUM |
| Top | | | |
| 19 | 504 152 030 | 504 152 031 | — |
| 20 | 504 151 912 | 504 152 328 | — |
| 21 | 504 151 500 | 504 096 200 | — |
| 22 | 504 083 500 | 504 091 100 | — |
| 23 | 504 085 400 | 504 091 000 | — |
| 24 | 504 139 700 | 504 090 900 | — |
| 25 | — | 504 084 300 | — |
| 26 | — | 504 085 300 | — |
| 27 | — | 504 148 400 | — |
| Bottom | | | |
| 40 | — | — | — |
| 41 | — | — | — |
| 42 | — | — | — |
| 43 | — | 504 148 500 | 486 104 600 |
| 44 | — | 504 085 500 | — |
| 45 | 504 152 379 | — | 486 104 700 |
| 46 | — | — | — |
| 47 | — | — | 486 104 800 |

| # OF TEETH | 15 WIDE | | |
|------------|-------------|-------------|-------------|
| | STEEL | POWDER | ALUMINUM |
| Top | | | |
| 19 | 486 092 600 | — | — |
| 20 | 486 092 700 | — | — |
| 21 | 504 152 044 | 504 151 913 | — |
| 22 | 486 074 600 | 504 151 914 | — |
| 23 | 486 093 000 | — | — |
| 24 | — | 504 151 930 | — |
| 25 | — | — | — |
| 26 | — | 504 151 931 | — |
| 27 | — | 504 148 900 | — |
| Bottom | | | |
| 42 | — | — | — |
| 43 | — | 504 148 700 | 486 400 006 |
| 44 | — | — | — |
| 45 | — | — | 486 400 007 |
| 46 | — | — | — |
| 47 | — | — | — |

| CHAIN | 13 LINK | 15 LINK |
|----------|-------------|-------------|
| 78 Pitch | - | 486 130 094 |
| 76 Pitch | 412 107 600 | 486 130 093 |
| 74 Pitch | 412 106 900 | 504 151 910 |
| 72 Pitch | 412 106 700 | 486 074 300 |

All 486 parts must be ordered from the Valcourt Race Dept. or the Ski-Doo Parts Support Truck.

TRANSMISSION CALIBRATION PROCEDURE

1. A new vehicle should be broken-in before fine tuning the transmission. 200 — 300 miles will allow things like bearings and the track to loosen-up. This will allow the sled to roll much freer which may slightly change the clutch calibration.
 2. Set up the chassis configuration (lowering, weight transfer, traction).
 3. Adjust the carburetor calibration to match the condition of the day.
 4. Pick the chain case ratio.
 5. Define the driven pulley calibration. Stock is a good starting point. Drag racers may consider trying a larger cam angle. Use multi-angle cams only for fine tuning after working with the drive clutch.
 6. Choose the drive belt (compound, length, width).
 7. Define the TRA calibration.
 - Start with the stock ramp in position #3.
 - For most forms of racing, a higher engagement RPM can be utilized. The better the traction, the higher the engagement that can be used. Most stock grass drag rules limit engagement to 5500 RPM. That's 5500 RPM on the technical inspector's tachometer and it may not agree with your dash tachometer. If in doubt, get the tech. man to verify your engagement. The easiest way to raise engagement is to use a spring with a higher start load and a similar finish load. Remember, the stiffer spring at start will also affect the shift curve at 0 to 1/2 ratio.
 - If the stiffer spring slowed down the shift at low ratios, try more roller pin weight. The pin weight will not change engagement much but will shift faster. Utilize the threaded roller pins to achieve pin weights in between the hollow steel and solid steel pin.
 - Fine tune the shift curve by trying different adjuster positions. Use the lowest adjuster number that still allows you to maintain RPM.
 - Pin weight and ramp angle are interrelated, but can be varied to achieve certain results. A 16.5 gram pin and the adjuster set in #5 may produce the same full throttle RPM as a 14.5 gram pin with the adjuster set in #3, but the lighter pin will be revving higher at part throttle setting at low ratios. This may work better for snowcross or woods racing whereas the heavier pin may be better in a drag race. Some ramp profiles will achieve better top speed with the adjusters set in lower numbers (1-4). If you are in position 5 or 6, try a slightly lighter pin weight (1.5 to 2 grams) and lower the adjuster position.
- NOTE:** Never use adjuster position #6 with the FZ ramp. The tip of the ramp may touch the lever arm.
- If your shift curve is perfect but the engagement is too low, a flat or notch can be ground in the ramp right where the roller sits at neutral position. This is a touchy procedure and should only be attempted as a last resort. Be prepared to scrap some ramps during the learning procedure.
 8. The best way to test clutching is with a set of timing lights or side by side comparison with a similar vehicle. Leave one machine as a base line reference while tuning the test vehicle. Don't change things on both vehicles at the same time or you won't know if you are gaining or losing. Also, only change one parameter at time on your test vehicle so you know exactly what results from the change.
 9. For drag racers, try running the engine down to several hundred RPM below the stated power peak. When the exhaust is cold, the peak power RPM drops. How much lower depends on the engine type, exhaust type, jetting and underhood temperature. Summer and fall grass draggers should especially try lower RPM.
 10. This is where the winners become winners. Test, test, test and then go test some more.
 11. **KEEP DETAILED NOTES OF ALL YOUR TESTINGS!!!** No matter how good you think your memory is, after you test your hundredth combination, things can get overwhelming.

SECTION 05 - DRIVE SYSTEM

TRANSMISSION TUNING TEST SHEET

DATE: _____ VEHICLE: _____ SHEET NO.: _____
 TEST SITE: _____ TEMPERATURE: _____ SURFACE COND.: _____

| | TEST 1 | TEST 2 | TEST 3 | TEST 4 | TEST 5 |
|--------------------------------------|--------|--------|--------|--------|--------|
| Cam angle | | | | | |
| Spring color code | | | | | |
| Spring preload, lb | | | | | |
| Spring position ex.: (A-4) | | | | | |
| Chaincase gearing | | | | | |
| Lever arm and pin type | | | | | |
| Weight each assembly | | | | | |
| Ramp identification | | | | | |
| No. of set screws added (if used) | | | | | |
| Spring color code/tension | | | | | |
| TRA adjuster position | | | | | |
| Belt part number | | | | | |
| Width | | | | | |
| Length | | | | | |
| Engagement RPM | | | | | |
| Shift RPM | | | | | |
| Top speed | | | | | |
| Time for run/measured distance | | | | | |
| Variation min./max. | | | | | |
| Special notes | | | | | |

SECTION 05 - DRIVE SYSTEM

RACERS LOG

| | | | | |
|------------------------------|-----|----------------------|--------------------|---------------|
| VEHICLE: | | DATE: | | SHEET NUMBER: |
| LOCATION: | | SURFACE CONDITIONS: | | |
| TEMPERATURE: | | BAROMETRIC PRESSURE: | | HUMIDITY: |
| CARBURETOR SIZE: | | FUEL: | | C.R.A.D.: |
| | PTO | MAG | Carburetion notes: | |
| Main jet | | | | |
| Needle jet | | | | |
| Jet needle | | | | |
| E-clip position | | | | |
| Slide cut-away | | | | |
| Pilot jet | | | | |
| Drive pulley | | | Clutching notes: | |
| Lever arm/pin type | | | | |
| Pin weight | | | | |
| Ramp identification | | | | |
| TRA adjuster position | | | | |
| Spring identification | | | | |
| Spring pressure @ engagement | | | | |
| Spring pressure @ full shift | | | | |
| Engagement RPM | | | | |
| Shift RPM | | | | |
| Drive belt identification | | | | |
| Driven pulley | | | | |
| Cam identification | | | | |
| Spring identification | | | | |
| Spring preload and location | | | | |
| Chaincase gearing | | | | |
| | LH | RH | Chassis notes: | |
| Inches of carbide/ski | | | | |
| Camber | | | | |
| Front spring identification | | | | |
| Ride height | | | | |
| Center spring identification | | | | |
| Limiters adjustment | | | | |
| Rear spring identification | | | | |
| Ride height | | | | |
| Stud quantity and type | | | | |

BRAKE

HYDRAULIC BRAKE

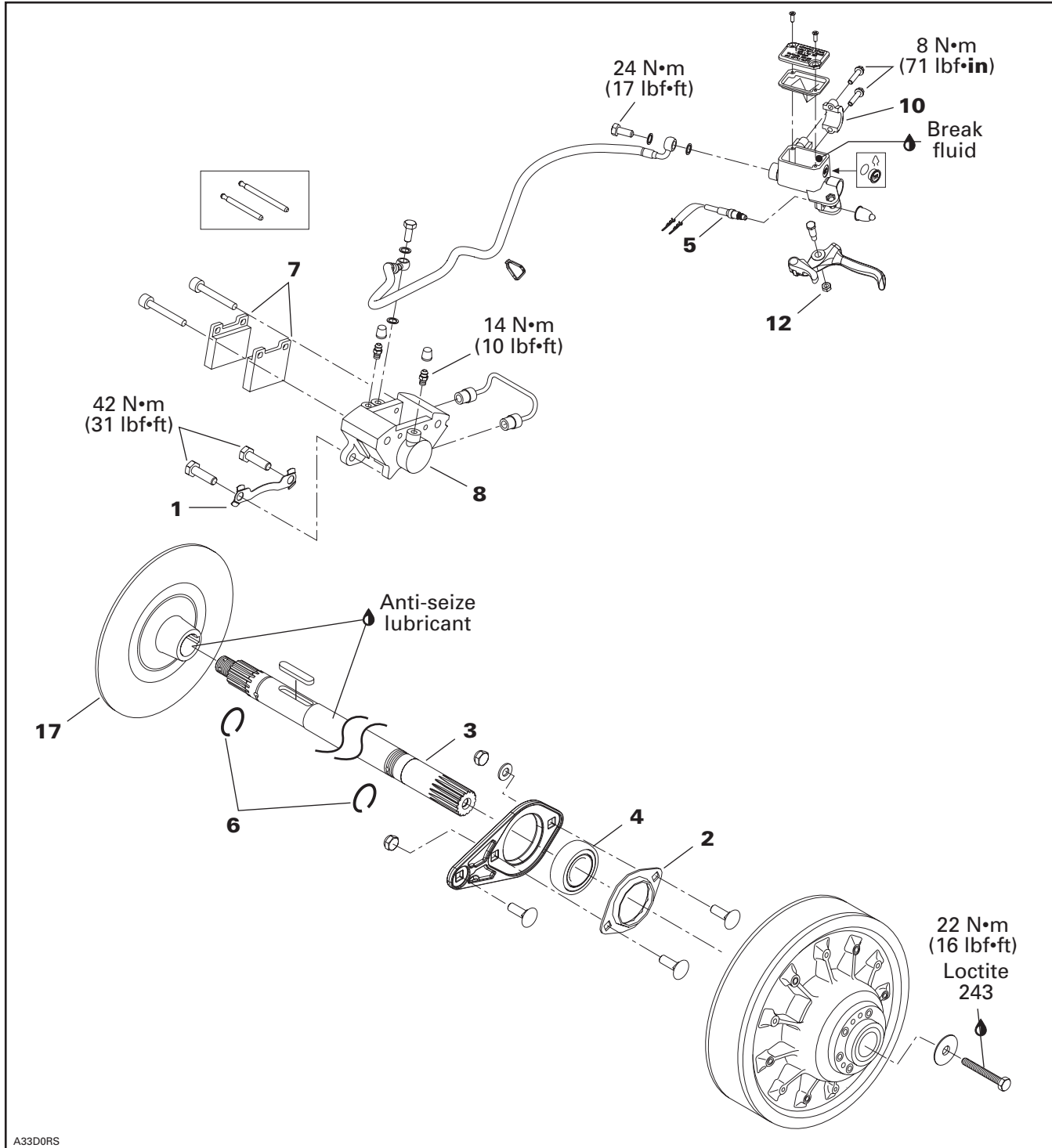

BRAKE FLUID TYPE

Use recommended brake fluid SRF (DOT 4) (P/N 293 600 063) or GTLMA (DOT 4) (P/N 293 600 062).

CALIPER

Removal

Caliper no. 8 can be removed as follows:

- Unscrew 2 screws and remove locking tab no. 1.

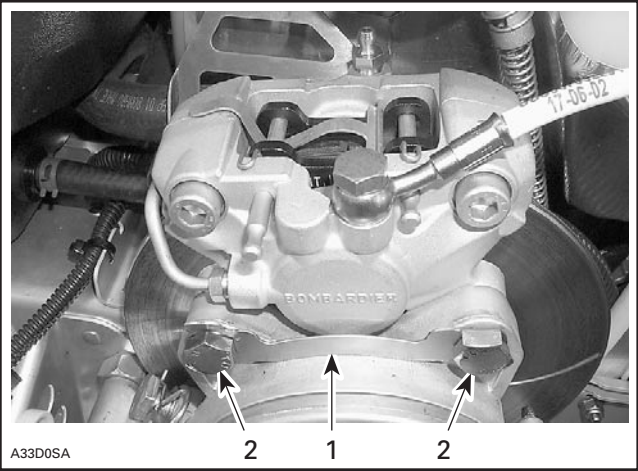

- 1. Locking tab
- 2. Screws

- Pull out caliper from the brake disc.

Installation

- Install caliper on the brake disc.
- Install locking tab.

BRAKE PADS REPLACEMENT

Brake pads must be replaced when lining is 1 mm (1/32 in) thick or less.

CAUTION: Brake pads must always be replaced in pairs.

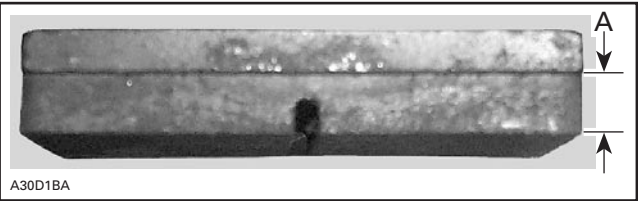

A. 1 mm (1/32 in) minimum

Removal

Brake pads removal procedure is as follows:

- Remove 2 retainers from the pins.
- Pull out 2 pins which releases the spring.
- Remove the brake pads.

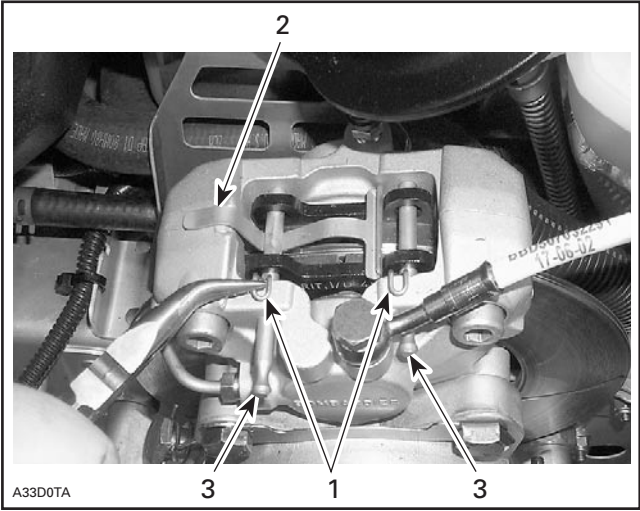

- 1. Retainer
- 2. Spring
- 3. Pin

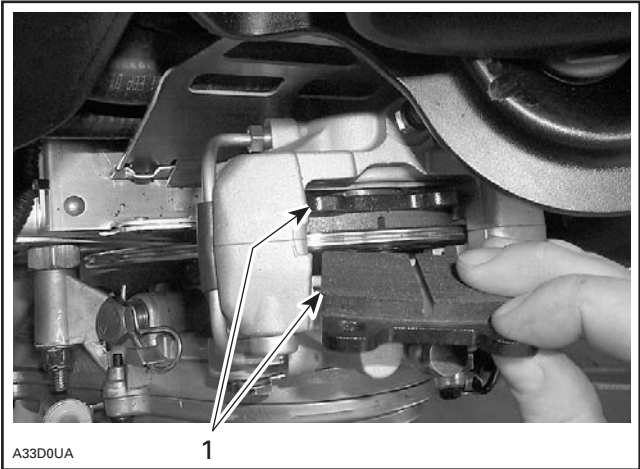

- 1. Brake pad

SECTION 05 - DRIVE SYSTEM

Installation

- Install new brake pads.
- Install spring and push 2 pins to lock the brake pads.
- Install 2 retainers in the pin holes.

To install brake, reverse removal procedure pay attention to the following.

⚠ WARNING

Avoid getting oil on brake pads.

Each time a new caliper or new brake pads are installed, proceed with the following:

- With caliper not bolted to chaincase, apply brake few times until both new pads are touching each other.
- Push back pads and repeat above step.
- Push back pads then fasten caliper to chaincase.
- Proceed with bleeding as described in this subsection.

REMOVAL

BRAKE DISC REMOVAL

Brake disc can be removed without removing chaincase. Proceed as follows:

- Remove belt guard, belt and driven pulley.
- Remove air silencer.
- Loosen the carburetor.
- Unbolt bearing support **no. 2** from chassis.
- Unscrew caliper from chaincase.

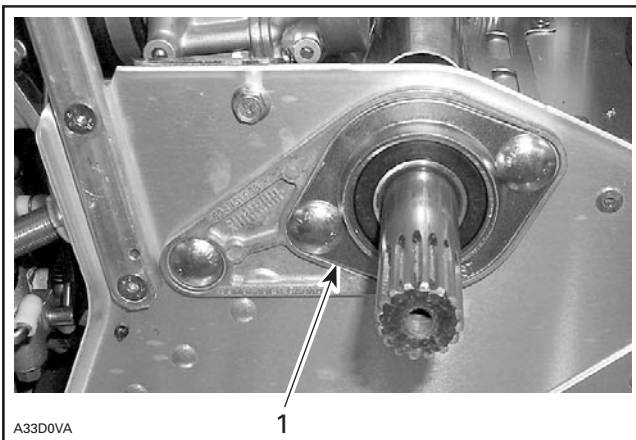

1. Bearing support

- Open chaincase and remove upper sprocket.
- Pull countershaft **no. 3** toward driven pulley side to free from chaincase and disc.
- Remove disc.

COUNTERSHAFT BEARING REMOVAL

Unbolt bearing support **no. 2**. Install screws on the remover (P/N 529 035 699).



Install remover (P/N 529 035 699) on countershaft for complete bearing removal.

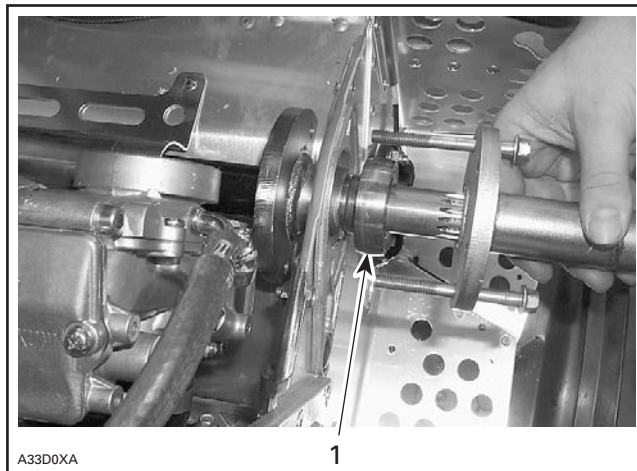

1. Bearing

COUNTERSHAFT REMOVAL

Proceed the same as for brake disc and countershaft bearing removal and then remove the countershaft.

DISASSEMBLY

7, Brake Pad

Only brake pads are available as spare parts. If caliper or master cylinder are damaged, replace each of them as an assembly.

CLEANING

Clean all metal components in a general purpose solvent. Thoroughly dry all components before assembling.

CAUTION: Do not clean brake pads in solvent. Soiled brake pads must be replaced by new ones.

INSPECTION

7, Brake Pad

CAUTION: Brake pads must always be replaced in pairs.

Brake pads must be replaced when lining is 1 mm (1/32 in) thick or less. Refer to the photo in BRAKE PADS REPLACEMENT.

17, Brake Disc

Check for scoring, cracking or bending, replace as required.

CAUTION: Brake disc should never be machined.

INSTALLATION

Apply anti-seize lubricant (P/N 293 800 070) on shaft.

The disc hub exceeds the disc more from one side than from the other. Install disc with the longer exceeding portion toward driven pulley.

7, Brake Pad

After brake pads installation, brake disc must be centered in caliper. Apply brake then check for proper brake disc positioning.

Push on appropriate caliper piston in order to move pad inward allowing proper brake disc positioning.

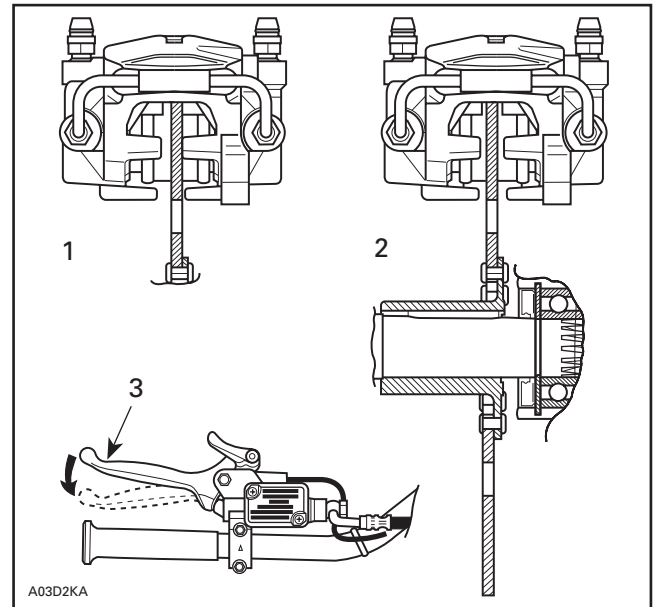

1. Brake disc not centered
2. Brake disc centered
3. Apply brake before checking

Apply brake then recheck.

Countershaft Bearing Adjustment

Insert countershaft (with brake disc) from chaincase side through countershaft support (driven pulley side), then insert into chaincase.

Install countershaft bearing **no. 4** using proper tool.

To install bearing on countershaft, use remover (P/N 529 030 100) and some flat washers of 3 mm (1/8 in) total thickness. Using original retaining screw and shouldered washer tighten until bearing rests against circlip.

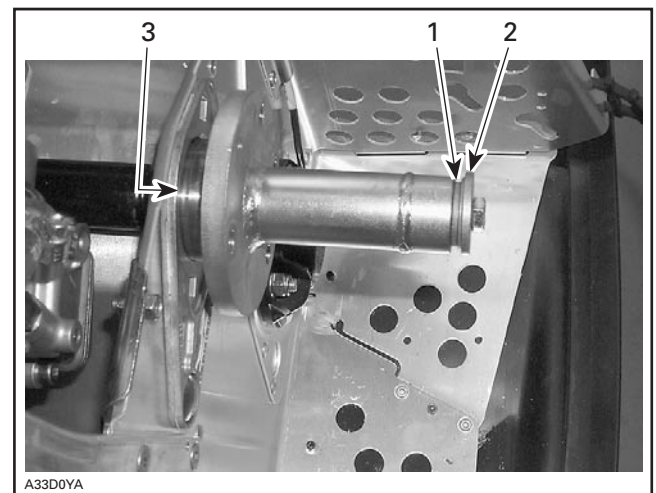

1. Washers use as a 3 mm (1/8 in) spacer
2. Original retaining screw and shouldered washer
3. Bearing against circlip

SECTION 05 - DRIVE SYSTEM

Ensure that countershaft is properly aligned, then tighten 3 retaining screws.

NOTE: A misaligned countershaft will result in difficulty to center the bearing in its support.

Torque castellated nut of upper sprocket to 45 to 75 N•m (33 to 55 lbf•ft).

Close chaincase referring to CHAINCASE.

5,12, Brake Cable and Nut

Insert brake cable into upper hole in brake lever and caliper. Install nut and tighten until a few threads exceed.

WARNING

At least 3 threads must exceed the elastic stop nut.

ADJUSTMENT

Brake

Bleed brake system as follows:

Keep sufficient SRF (DOT 4) (P/N 293 600 063) or GTLMA (DOT 4) (P/N 293 600 062) brake fluid in reservoir at all times.

CAUTION: Use only SRF (DOT 4) (P/N 293 600 063) or GTLMA (DOT 4) (P/N 293 600 062) brake fluid.

Install a hose on bleeder. Route this hose to a container. Open bleeder.

Pump brake lever until no air escapes from hose. Close bleeder.

5, Brake Light Switch

There is no adjustment on these models. Check that switch is securely installed.

BLEEDING

Change brake fluid often.

Bleed brake system as follows:

Keep sufficient SRF (DOT 4) (P/N 293 600 063) or GTLMA (DOT 4) (P/N 293 600 062) 4 brake fluid in reservoir at all times.

CAUTION: Use only SRF (DOT 4) (P/N 293 600 063) or GTLMA (DOT 4) (P/N 293 600 062) brake fluid.

Install a clear hose on bleeder. Route this hose to a container. Open bleeder.

Pump brake lever until no air escapes from hose. Close bleeder.

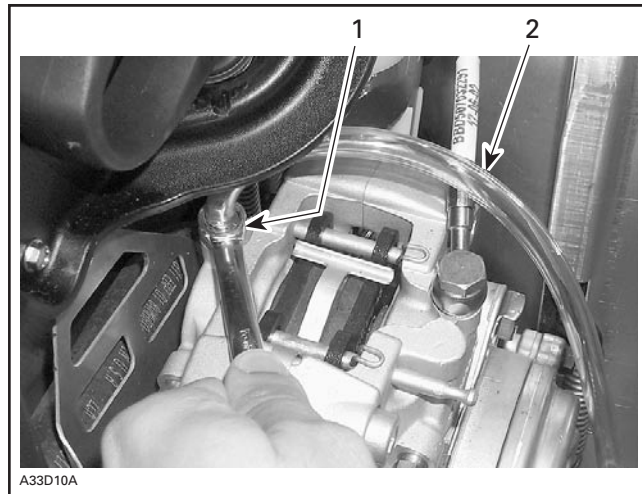

1. Open bleeder
2. Clear hose to catch used brake fluid

WARNING

Avoid getting oil on brake pads. Do not lubricate or apply antirust or antifreeze solution in brake cable.

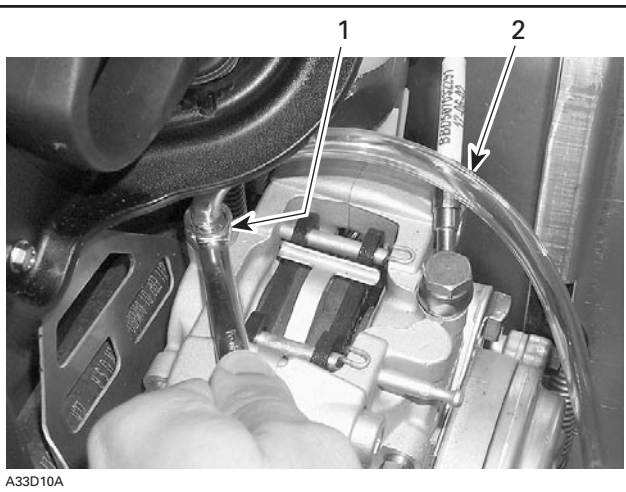

1. Open bleeder
2. Clear hose to catch used brake fluid

CHAINCASE

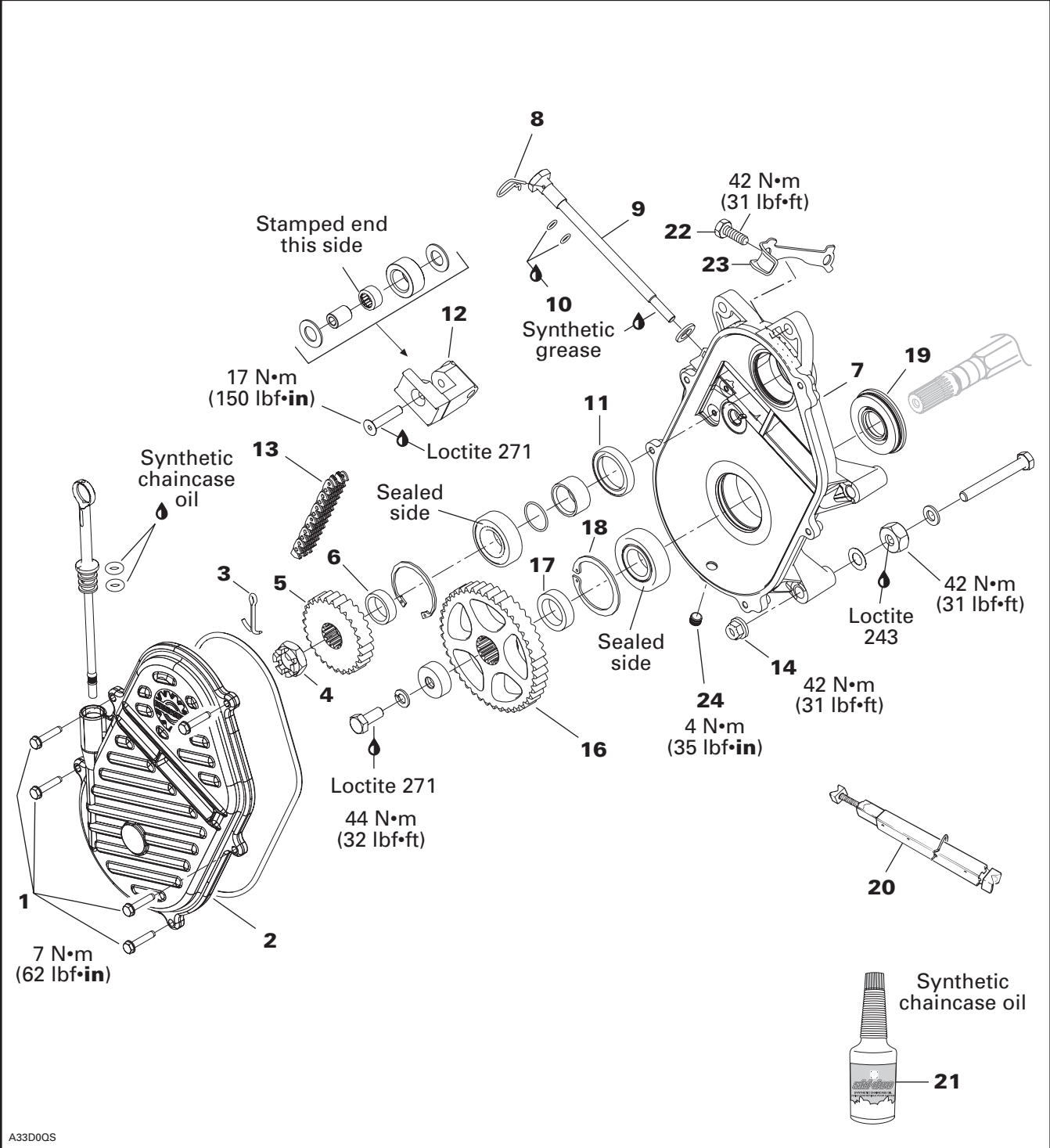

A33D0QS

SECTION 05 - DRIVE SYSTEM

REMOVAL AND DISASSEMBLY

To remove chaincase proceed as follows.

Remove hair pin **no. 8**. Release drive chain tension by unscrewing tensioner adjustment screw.

Drain oil by removing drain plug **no. 24**.

Remove 5 screws **no. 1**

3,4,5,6,13,16,17, Cotter Pin, Nut, Sprocket, Shim and Drive Chain

Apply parking brake.

Remove cotter pin **no. 3** and nut **no. 4** retaining upper sprocket **no. 5** and screw **no. 15** retaining lower sprocket **no. 16**. Pull sprockets and drive chain simultaneously. Remove shims **nos. 6** and **17**.

NOTE: Should countershaft removal be required, refer to BRAKE then look for COUNTERSHAFT REMOVAL.

Release parking brake.

Remove 3 nuts **no. 14**.

Unfold locking tab **no. 23** then remove caliper retaining screws **no. 22**.

Release track tension, use drive axle holder **no. 20** (P/N 529 007 200).

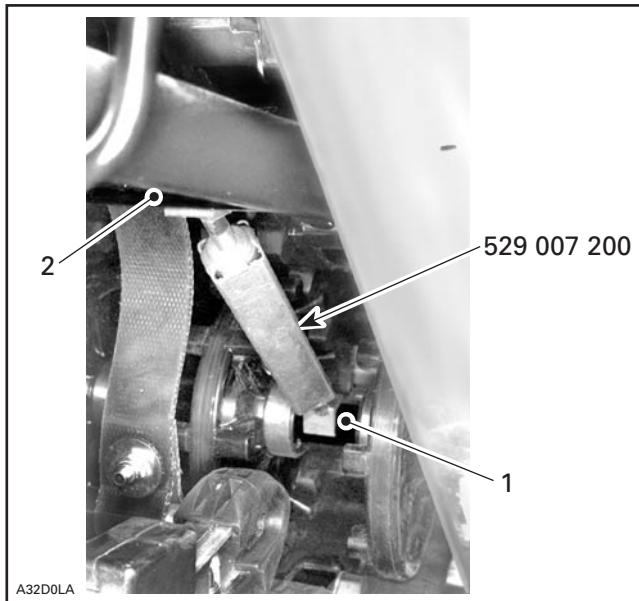

TYPICAL

3. Drive axle

4. Suspension front arm upper axle

Pry out drive axle oil seal **no. 19** from chaincase.

Pull chaincase from drive axle and countershaft.

Using 2 large prybars inserted between chaincase housing **no. 7** and frame, pry complete assembly from vehicle.

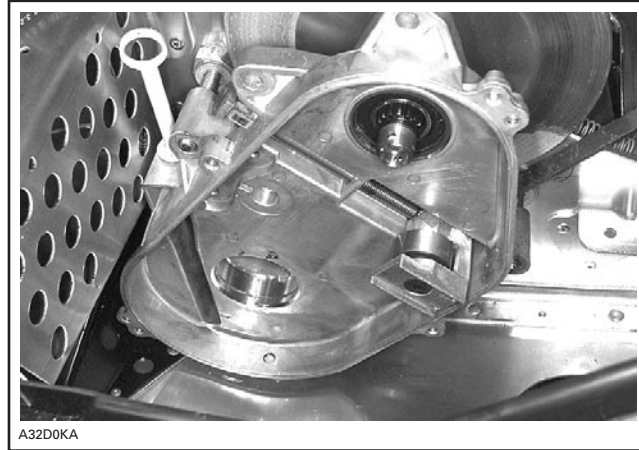

TYPICAL — CHAINCASE HOUSING REMOVAL

INSPECTION

Visually inspect the chain for cracked, damaged or missing links. Check for worn or defective bearings, sprockets and chain tensioner components.

WARNING

If chain deflection is greater than 38 mm (1.5 in) (without chain tensioner), replace chain and check condition of sprockets.

GEAR RATIO MODIFICATION

For particular applications, the number of teeth of the sprockets can be increased or decreased on lower and upper sprockets.

CAUTION: Gear ratio modifications should only be performed by experienced mechanics since they can greatly affect vehicle performance.

NOTE: For high altitude regions, a service bulletin will give information about calibration according to altitude.

INSTALLATION AND ASSEMBLY

Reverse removal and disassembly procedure and pay attention to the following. Replace oil seals, gaskets O-rings and drain plug.

25, Hardened Washer

Make sure to install a hardened washer on each end of spring.

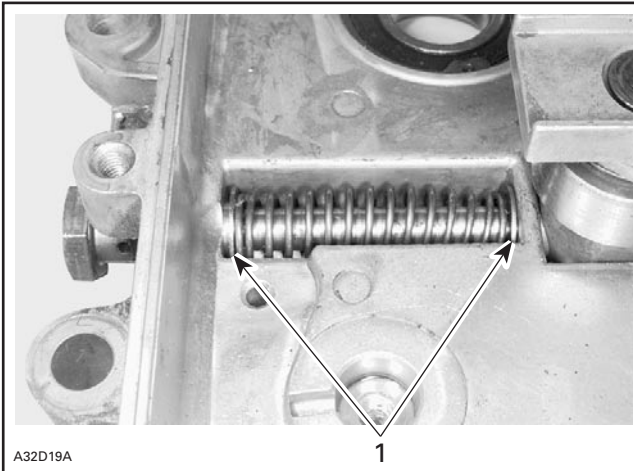

1. Hardened washers

11, Oil Seal

Using an appropriate pusher, press the oil seal into chaincase hub. Oil seal must fit flush with the chaincase edge.

NOTE: Should installation procedure for countershaft be required, refer to BRAKE.

5,16, Sprockets

Position the sprockets with the writing facing the chaincase cover. Sprocket hub faces toward chaincase.

4, Upper Sprocket Castellated Nut

Torque to 45 to 75 N•m (33 to 55 lbf•ft).

Install new cotter pin in the position shown.

CAUTION: When removing a cotter pin always replace with a new one.

CAUTION: Cotter pin will rub on chaincase cover if installed otherwise.

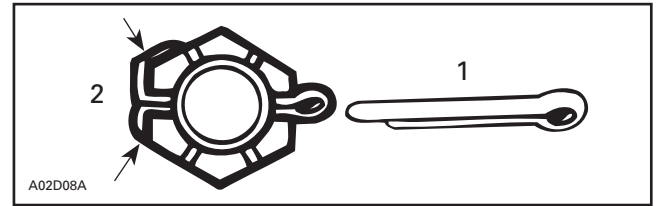

1. New
2. Fold cotter pin over castellated nut flats only

18, Circlip

CAUTION: It is of the utmost importance to install the circlip otherwise damage to the chaincase components may occur.

DRIVE CHAIN ADJUSTMENT

NOTE: Brake disc key must be in good condition before checking if chain is loose.

10, O-Ring

Replace O-ring no. 10 on tensioner adjustment screw. Fully tighten tensioner adjustment screw **by hand**, then back off only far enough for hair pin to engage in locking hole.

This initial adjustment should provide 3 - 5 mm (1/8 - 13/64 in) free-play when measured at the outer circumference of the brake disc.

CAUTION: Free-play must not exceed 5 mm (13/64 in), readjust if necessary.

WARNING

If the specified free-play is not reached with the tensioner screw fully tightened, replace chain and check the condition of sprockets.

21, Chaincase Oil

Pour 250 mL (8.5 U.S. oz) of synthetic chaincase oil (P/N 413 803 300) into chaincase.

NOTE: Chaincase oil capacity is 250 mL (8.5 U.S. oz).

Check oil level with the dipstick then add if required. Remove metal particles from magnet.

SECTION 05 - DRIVE SYSTEM

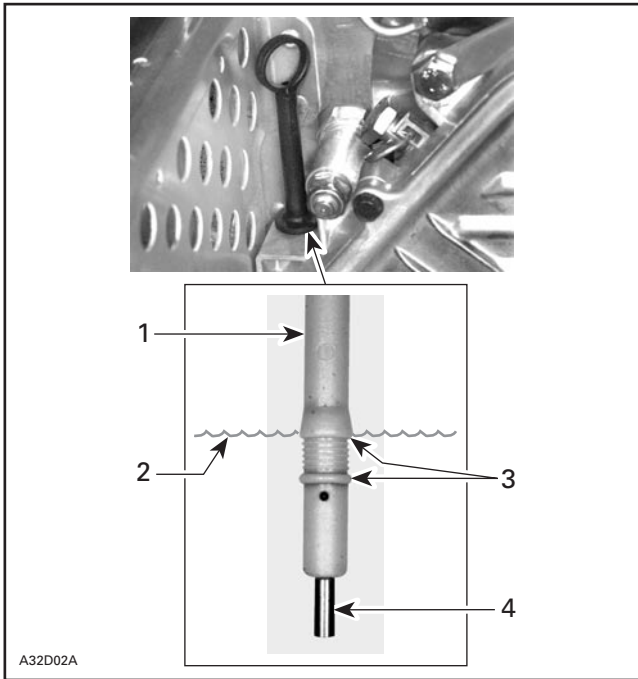

TYPICAL

1. Dipstick
2. Oil level
3. Level between marks
4. Magnet

NOTE: Chaincase must be in its proper position when checking oil level.

ADJUSTMENT

Pulley Alignment

Refer to PULLEY DISTANCE AND ALIGNMENT.

Track Tension and Alignment

Refer to TRACK.

DRIVE AXLE

REV Series Models

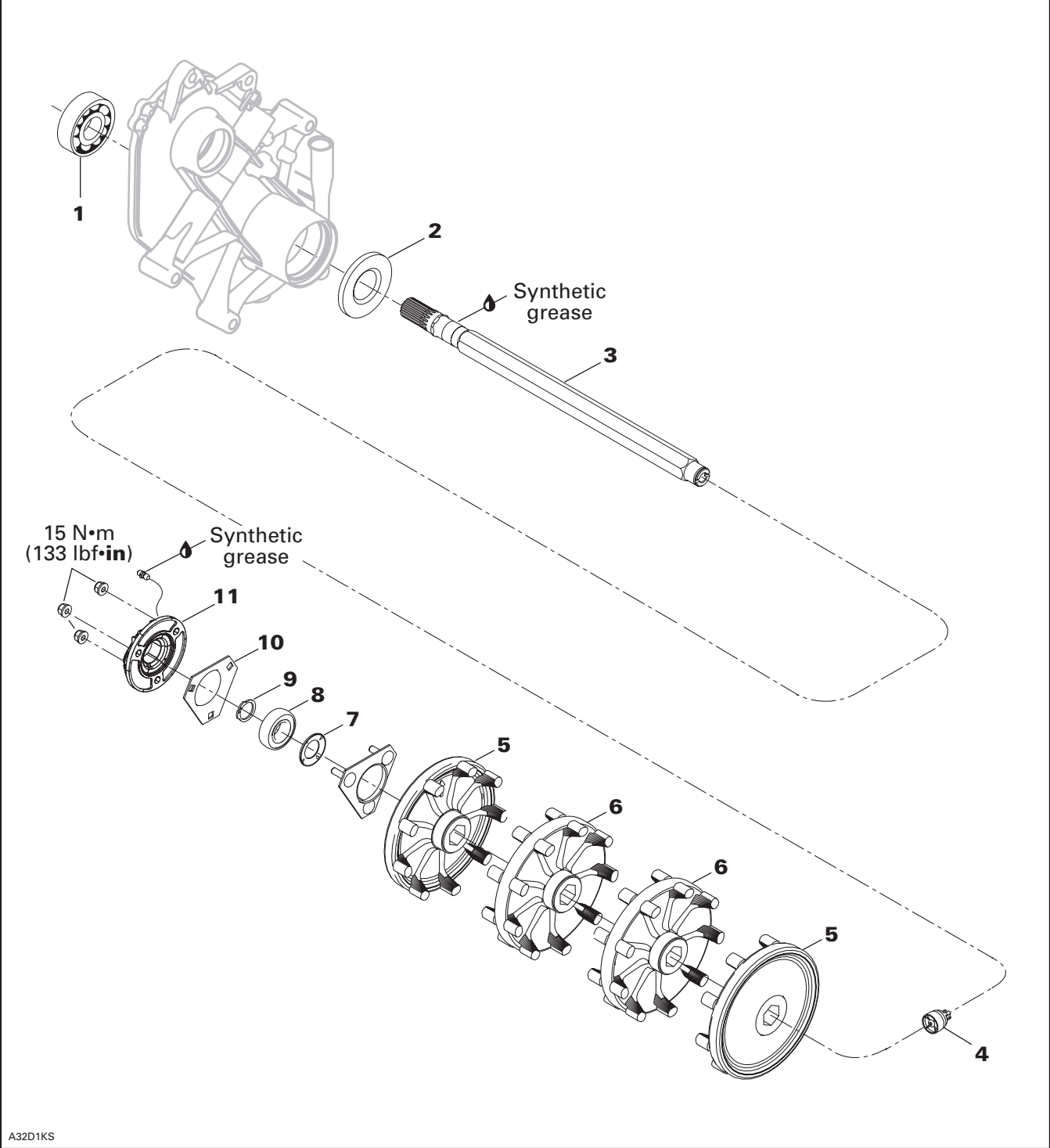

SECTION 05 - DRIVE SYSTEM

REMOVAL

Remove battery (if so equipped) to gain access, refer to BATTERY section.

Drain oil from chaincase. Remove chaincase cover. Release drive chain tension.



TYPICAL

Raise and block rear of vehicle off the ground.

Remove suspension. Refer to proper subsection.

Track can be held in tunnel using a rod in place of center idler wheel axle.

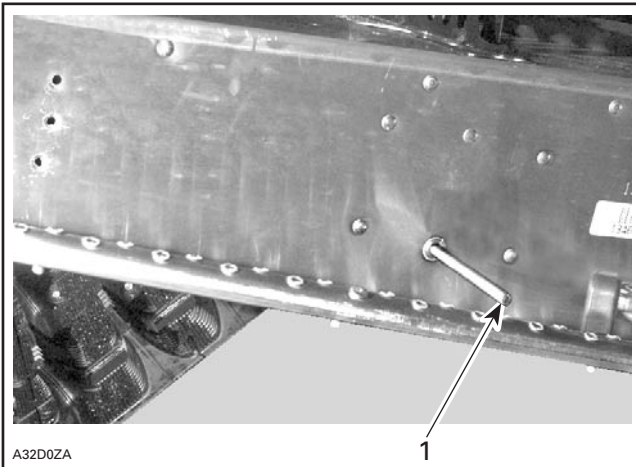

1. Rod

Remove speed sensor no. 11, outer flange no. 10 and circlip no. 9 from left side.

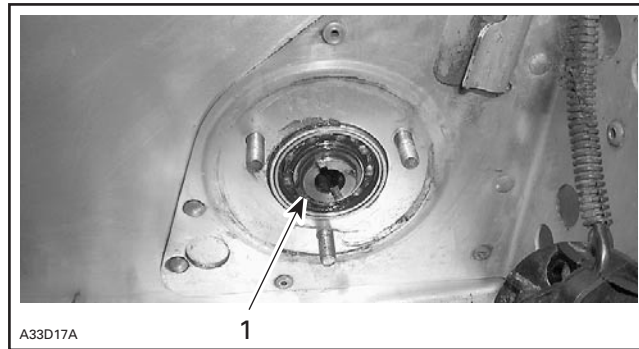

1. Circlip

Apply parking brake.

Remove chain and sprockets then circlip from right side.

Release drive axle sprocket from track and at the same time, push the drive axle no. 3 toward the right side. Drive axle bearing no. 1 in chaincase or gear-box will fall off.

5,6, Sprocket and Half-Sprocket

To remove press fit sprockets, use a press and a suitable support as illustrated.

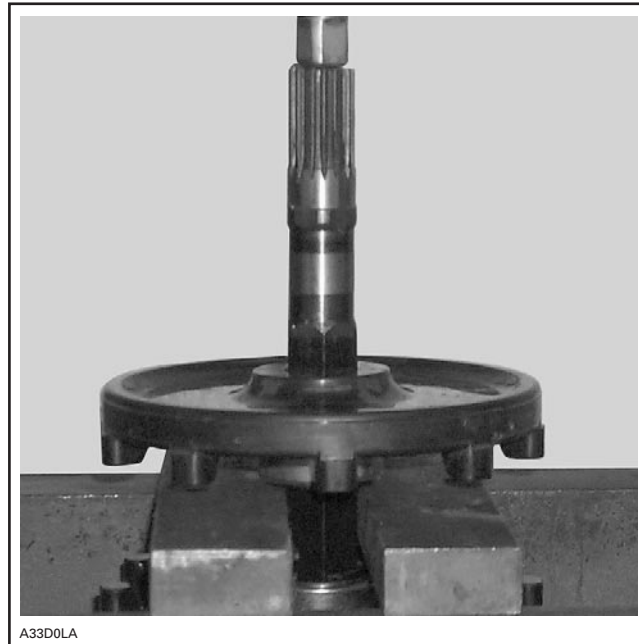

SUPPORT SPROCKET NEAR HUB

ASSEMBLY

3,5,6, Drive Axle and Sprocket

To assemble press fit sprockets, use a press and a suitable pipe as illustrated. Sprockets must be assembled according to the following dimensions.

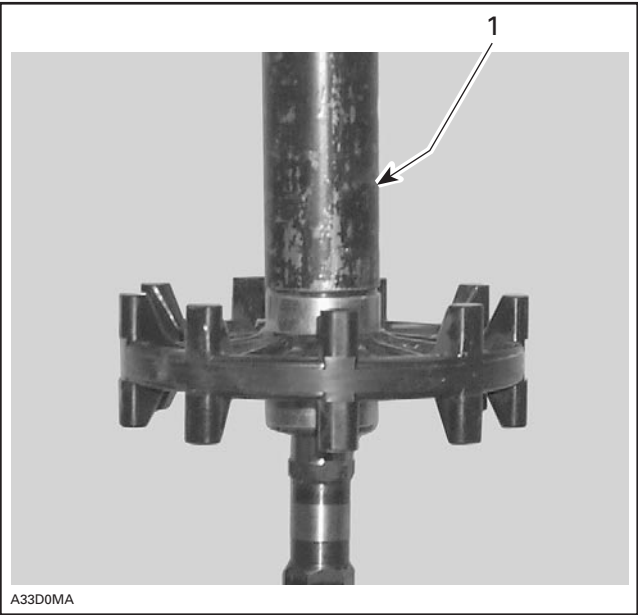

1. Pipe

REV Series

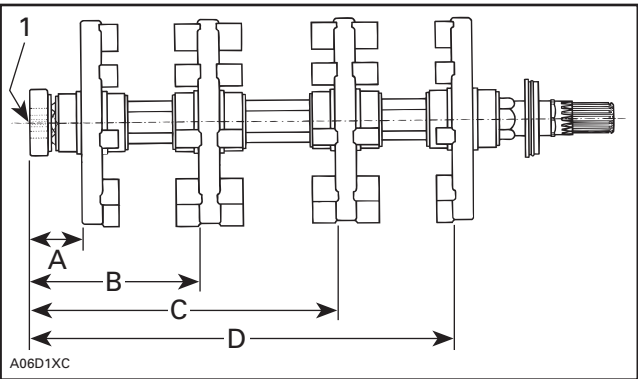

- 1. Measure from end of drive axle
- A. 48.5 mm (1.909 in)
- B. 151.0 mm (5.944 in)
- C. 274.0 mm (10.787 in)
- D. 376.5 mm (14.822 in)

Ensure to align indexing marks of each sprocket when assembling.

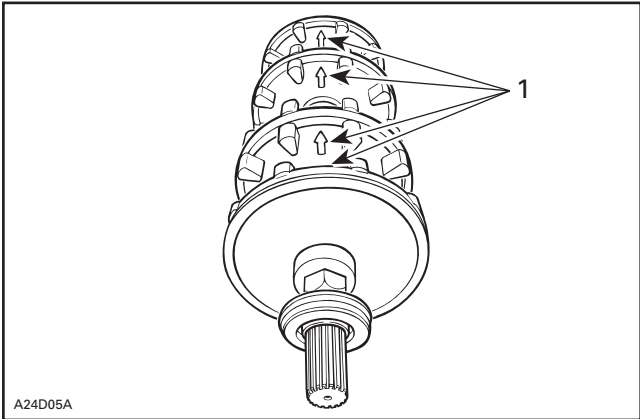

TYPICAL

- 1. Indexing marks aligned

The maximum desynchronization for the sprockets is 1.5 mm (1/16 in).

To check this tolerance, place axle assembly on a plane surface and measure the gap between sprocket tooth and surface.

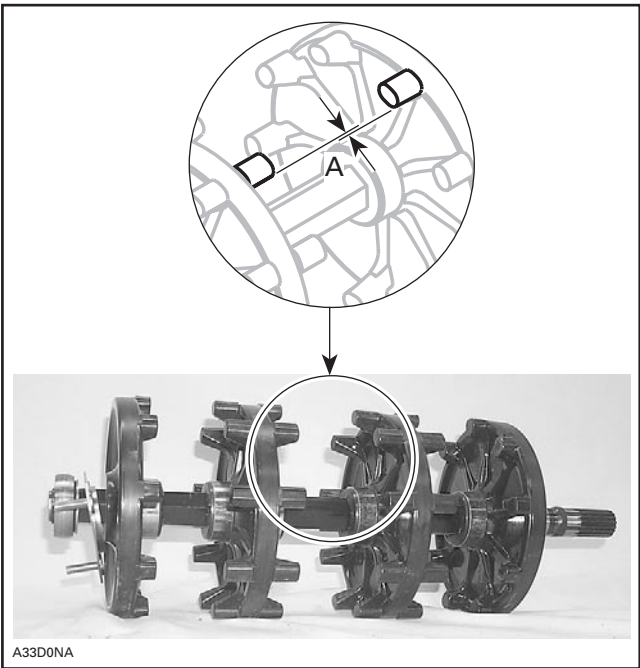

A. 1.5 mm (1/16 in) MAXIMUM

CAUTION: The same sprocket must not be pressed twice on the axle. If synchronization is found to be defective, use a new sprocket.

SECTION 05 - DRIVE SYSTEM

7, Bearing Protector

At assembly, flat side of bearing protector must be against bearing.

8, Bearing

Always push bearing by inner race.

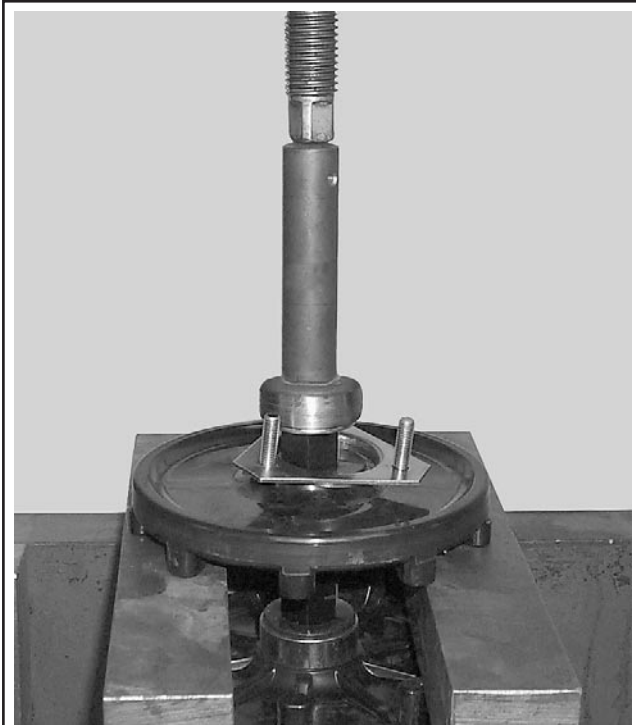

The bearing no. 8 must have its shield facing the sprocket.

The bearing no. 1 must have its shield facing right side (cover).

LUBRICATION

Lubricate end housing bearing with synthetic grease (P/N 413 711 500).

ADJUSTMENT

Sprocket/Track Alignment

CAUTION: Do not temper with sprocket/track alignment if frame or suspension is damaged.

Sprockets might be repositioned to fit lugs without removing drive axle.

Use drive axle sprocket adjuster kit (P/N 861 725 700).

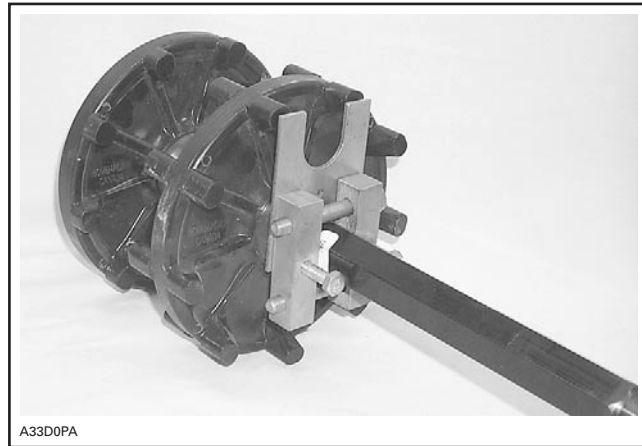

TYPICAL

TRACK

TRACK TYPE APPLICATION

Refer to TECHNICAL DATA.

GENERAL

This section gives guidelines for track removal. Some components require more detailed disassembly procedures. In these particular cases, refer to the pertaining section in this manual.

INSPECTION

Visually inspect track for:

- cuts and abnormal wear
- broken rods
- broken or missing track cleats.

If track is damaged or rods are broken, replace track. For damaged or missing cleats, replace by new ones, using cleat remover (P/N 529 028 700). Use narrow-cleat installer (P/N 529 008 500).

⚠ WARNING

Do not operate a snowmobile with a cut, torn or damaged track.

REMOVAL

Remove the following parts:

- driven pulley
- speedometer cable
- end bearing housing
- chaincase or gearbox cover
- sprockets and chain
- rear suspension
- drive axle seal
- drive axle
- track.

INSTALLATION

Reverse the removal procedure.

NOTE: When installing the track, respect rotation direction indicated by an arrow on track thread.

Check sprocket/track alignment as described in DRIVE AXLE.

ADJUSTMENT

Track Tension and Alignment

Track tension and alignment are inter-related. Do not adjust one without checking the other. Track tension procedure must be carried out prior to track alignment.

Track Tension

NOTE: Ride the snowmobile in snow about 15 to 20 minutes prior to adjusting track tension.

Lift snowmobile by a rope, chain or lift strap that has been secured into holes provided for that purpose, one on each side of tunnel rear.

Allow the rear suspension to fully extend and check gap half-way between front and rear idler wheels. Measure between slider shoe bottom and inside of track. The gap should be as given in SPECIFICATIONS. If the track tension is too loose, track will have a tendency to thump.

NOTE: A belt tension tester (P/N 414 348 200) may be used to measure deflection as well as force applied.

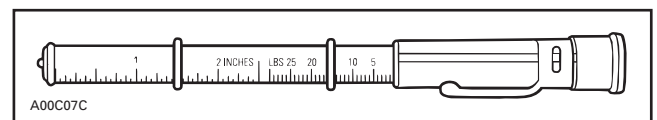

BELT TENSION TESTER

SECTION 05 - DRIVE SYSTEM

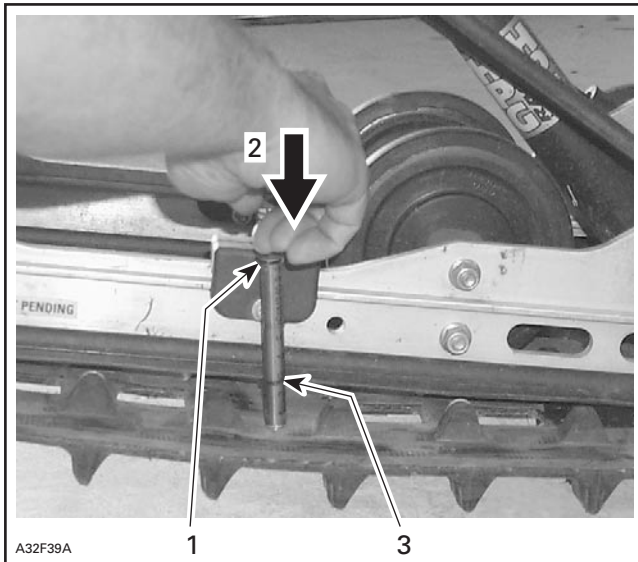

1. Top tool O-ring positioned at 7.3 kg (16 lb)
2. Push on top portion of tool until it contacts the top O-ring
3. Measured track deflection

CAUTION: Too much tension will result in power loss and excessive stresses on suspension components.

To adjust tension:

- Loosen one of the rear idler wheel retaining screws.
- Loosen the lock nut on the adjustment screw.
- Turn adjustment screws to adjust.

Alignment

WARNING

Before checking track alignment, ensure that the track is free of all particles which could be thrown out while track is rotating. Keep hands, tools, feet and clothing clear of track. Ensure no one is standing in close proximity to the vehicle. Never rotate at high speed.

Start the engine and accelerate slightly so that track barely turns. This must be done in a short period of time (1 to 2 minutes)

Check that the track is well centered; equal distance on both sides between edges of track guides and slider shoes.

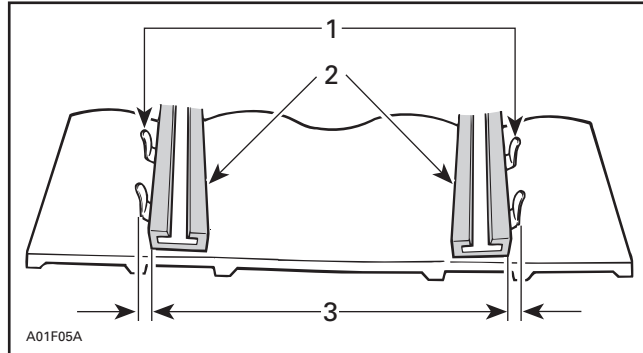

1. Guides
2. Slider shoes
3. Equal distance

To correct, stop engine, loosen rear wheel screws, then tighten the adjustment screw on side where the slider shoe is the farthest from the track insert guides.

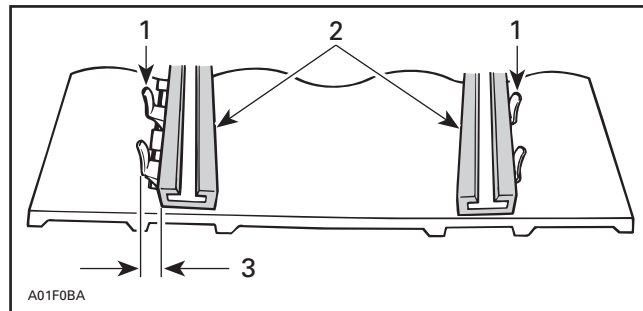

1. Guides
2. Slider shoes
3. Tighten on this side

Restart engine, rotate track **slowly** and recheck alignment. If the satisfactory alignment is achieved, then tighten the idler wheel retaining screws to 48 N•m (35 lbf•ft).

Track Cleat

Removal

- Raise rear of vehicle off the ground and lift snow-guard and snow deflector then hand rotate track to expose a cleat to be replaced.
- Using track cleat remover (P/N 529 028 700) for all models.

Installation

- Place new cleat in position on the track and using narrow track cleat installer (P/N 529 008 500) bend cleat then push tabs into rubber.

- Re-open installer, then position cleat tabs on open end of tool and squeeze tabs until they are indented in rubber.

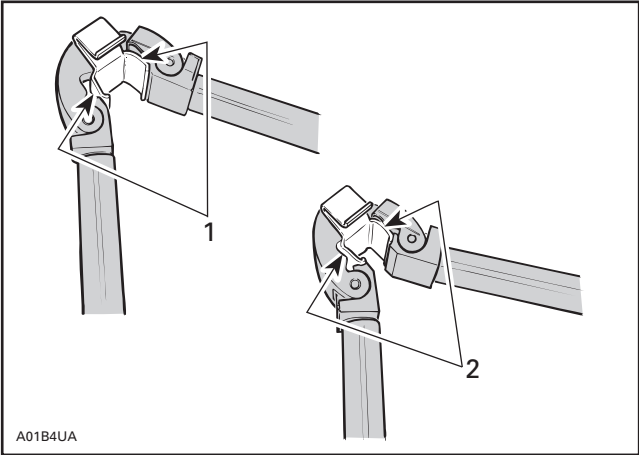

TYPICAL

1. First step
2. Second step (to push tabs into rubber)

TABLE OF CONTENTS

| | |
|---|------|
| 2004 OPEN MOD SNOCROSS ENGINE SPECIFICATIONS & PARTS 793 (ROTAX) 2 CYLINDERS | 06-2 |
| DRIVE CLUTCH PARTS LIST..... | 06-3 |

SECTION 06 - 2004 800 MOD ENGINE KIT

2004 OPEN MOD SNOXCROSS ENGINE SPECIFICATIONS & PARTS 793 (ROTAX) 2 CYLINDERS

| | |
|--|---|
| BORE | 82 mm |
| STROKE | 75.7 mm |
| CC | 799.2 cc |
| SQUISH | 1.4 mm (.055 in) |
| VOLUME COMBUSTION CHAMBER (FLAT PLATE) | 28.6 cc |
| CYLINDER HEAD INSERT DOME | P/N 420 613 810 |
| CYLINDER HEAD DOME COVER | P/N 420 613 802 |
| IGNITION | 290 watts |
| ELECTRONIC BOX | P/N M512 059 304 |
| DAMPER | P/N 420 866 990 |
| MAGNETO ASS'Y | P/N 420 888 665 |
| STATOR | P/N 420 888 665 |
| FLYWHEEL | P/N 410 922 954 |
| IGNITION COIL | P/N 512 059 564 |
| RAVE SPRING 0.8 X 52.0 | P/N 420 239 941 (blue) |
| NO THERMOSTAT | Use gasket P/N 420 850 338 (but put restriction in bypass hose with 1/8 dia. hole). |
| CONNECTING ROD | P/N 420 917 398 |
| CYLINDER | P/N M420 613 852 |
| RAVE VALVE | P/N 420 854 465 |
| VALVE COVER | P/N 420 911 558 |
| PISTON PIN BEARING | Cage less P/N 420 832 425 With cage P/N 420 832 442 (optional) |
| O-RING FOR CUP | P/N 420 950 890 |
| SQUARE O-RING | P/N 420 931 590 |
| O-RING | P/N 290 931 410 |
| PISTON | P/N 420 889 780 |
| PISTON RING (CKS) | P/N 420 815 360 |

| | |
|-----------------------------------|---|
| PISTON PIN | P/N 420 916 370 |
| CIRCLIP | P/N 420 845 106 |
| BASE GASKET AVAILABLE | <ul style="list-style-type: none"> .4 mm P/N 420 931 836 .5 mm P/N 420 931 838 .6 mm P/N 420 931 837 .7 mm P/N 420 931 964 (already installed on the engine) .8 mm P/N 420 931 839 |
| CRANKSHAFT | P/N 420 888 407 |
| CRANKCASE | P/N 420 890 160 |
| SEAL COVER | P/N 420 812 420 |
| SPARK PLUG | BR9ES (gap .016 in) P/N 414 961 100 |
| CONNECTING FLANGE (behind rewind) | P/N 420 810 867 |
| CARBURETOR | <p>TMS 38 Taper Bored P/N 486 130 002</p> <ul style="list-style-type: none"> • MJ 360 PTO 360 MAG @ 0° F • JN 6HDY35-58 P/N 486 400 029 <ul style="list-style-type: none"> - #2 pos from top @ 0° F • NJ 633 Q-4 P/N 486 228 100 <ul style="list-style-type: none"> - Opt. 633 Q-0 P/N 486 227 900 - Opt. 633 Q-2 P/N 486 228 000 - Opt. 633 Q-6 P/N 486 228 200 - Opt. 633 Q-8 P/N 486 228 300 • CA 4.0 P/N 486 228 900 • AS 0.5 turns • PJ 50 P/N 486 230 200 <ul style="list-style-type: none"> - Opt. 35 P/N 707 200 168 - Opt. 40 P/N 707 200 136 - Opt. 45 P/N 486 230 100 - Opt. 55 P/N 486 230 300 - Opt. 60 P/N 486 230 400 • VS 2.0 P/N 486 204 800 |
| AIR FILTER - KICKASS | P/N 486 100 400 |
| THROTTLE CABLE | P/N 486 130 007 |
| THROTTLE HANDLE | P/N 572 101 900 |
| FUEL PUMP (stock 440) | P/N 403 901 810 |
| REED VALVE (rimoldi ass'y) | Center w/slots P/N 420 924 905 Outside P/N 420 924 900 |

SECTION 06 - 2004 800 MOD ENGINE KIT

| | |
|---|--|
| DRIVE CLUTCH Clutch ass'y - forged Ramp 419 pos. 4 Arm, std. aluminum • Pin, metric WITH • 1 Metric Screw • 1 Metric Screw TOTAL WEIGHT (16.5 gr) • Opt. Set Screw, Metric (.73 gr) • Opt. Set Screw, Metric (1.7 gr) • Opt. Set Screw, Metric (2.3 gr) • Opt. Set Screw, Metric (3.0 gr) • Opt. Set Screw, Metric (3.8 gr) Spring 250-380 WHITE/WHITE | P/N 417 222 706 P/N 417 222 557 P/N 417 222 383 P/N 417 222 595 P/N 206 261 699 P/N 206 261 299 P/N 206 261 699 P/N 206 262 599 P/N 206 261 699 P/N 206 262 099 P/N 206 262 599 P/N 417 222 004 |
| DRIVEN CLUTCH (TEAM) • Cam - Twin Trac 44° & 48° The TEAM driven clutch cam has 2 cam angle positions. Set the Open Mod on 44° the stock 440 uses the 48° position • Spring-140/200, Red/Blue (TEAM) | P/N 420 565 000 P/N 210 064 000 |
| BELT MBL | P/N 414 300 253 |
| GEARING 22 - 45 | P/N 486 074 600 P/N 504 152 379 |
| CHAIN 74 LINKS | P/N 504 151 910 |
| BELT GUARD (meets ISR rules) | P/N M417 300 222 |
| BELT GUARD (side panel) | P/N 486 130 010 |

SECTION 06 - 2004 800 MOD ENGINE KIT

| | Engine Type: | 793 |
|--------|---------------------|-----------------------|
| | Stroke: | 75.7 |
| | C.R. Length: | 132 |
| DEGREE | PISTON POS. (mm) | PISTON POS. (inch) |
| 0 | 0 | 0.000 |
| 1 | 0.01 | 0.000 |
| 2 | 0.03 | 0.001 |
| 3 | 0.07 | 0.003 |
| 4 | 0.12 | 0.005 |
| 5 | 0.19 | 0.007 |
| 6 | 0.27 | 0.010 |
| 7 | 0.36 | 0.014 |
| 8 | 0.47 | 0.019 |
| 9 | 0.60 | 0.024 |
| 10 | 0.74 | 0.029 |
| 11 | 0.89 | 0.035 |
| 12 | 1.06 | 0.042 |
| 13 | 1.24 | 0.049 |
| 14 | 1.44 | 0.057 |
| 15 | 1.65 | 0.065 |
| 16 | 1.88 | 0.074 |
| 17 | 2.12 | 0.083 |
| 18 | 2.37 | 0.093 |
| 19 | 2.64 | 0.104 |
| 20 | 2.92 | 0.115 |
| 21 | 3.21 | 0.126 |
| 22 | 3.52 | 0.139 |
| 23 | 3.84 | 0.151 |
| 24 | 4.17 | 0.164 |
| 25 | 4.52 | 0.178 |

| | Engine Type: | 793 |
|--------|---------------------|-----------------------|
| | Stroke: | 75.7 |
| | C.R. Length: | 132 |
| DEGREE | PISTON POS. (mm) | PISTON POS. (inch) |
| 26 | 4.88 | 0.192 |
| 27 | 5.25 | 0.207 |
| 28 | 5.63 | 0.222 |
| 29 | 6.03 | 0.237 |
| 30 | 6.43 | 0.253 |
| 31 | 6.85 | 0.270 |
| 32 | 7.28 | 0.287 |
| 33 | 7.73 | 0.304 |
| 34 | 8.18 | 0.322 |
| 35 | 8.64 | 0.340 |
| 36 | 9.12 | 0.359 |
| 37 | 9.60 | 0.378 |
| 38 | 10.10 | 0.398 |
| 39 | 10.60 | 0.417 |
| 40 | 11.12 | 0.438 |
| 41 | 11.64 | 0.458 |
| 42 | 12.17 | 0.479 |
| 43 | 12.72 | 0.501 |
| 44 | 13.27 | 0.522 |
| 45 | 13.83 | 0.544 |
| 46 | 14.40 | 0.567 |
| 47 | 14.97 | 0.589 |
| 48 | 15.56 | 0.612 |
| 49 | 16.15 | 0.636 |
| 50 | 16.74 | 0.659 |

Recommended fuel:

Use Racing fuel **R + M** 114 octane (VP C14 or Phillips B33 with pre-mix oil 25 to 1 (good quality of synthetic oil)).

SECTION 06 - 2004 800 MOD ENGINE KIT

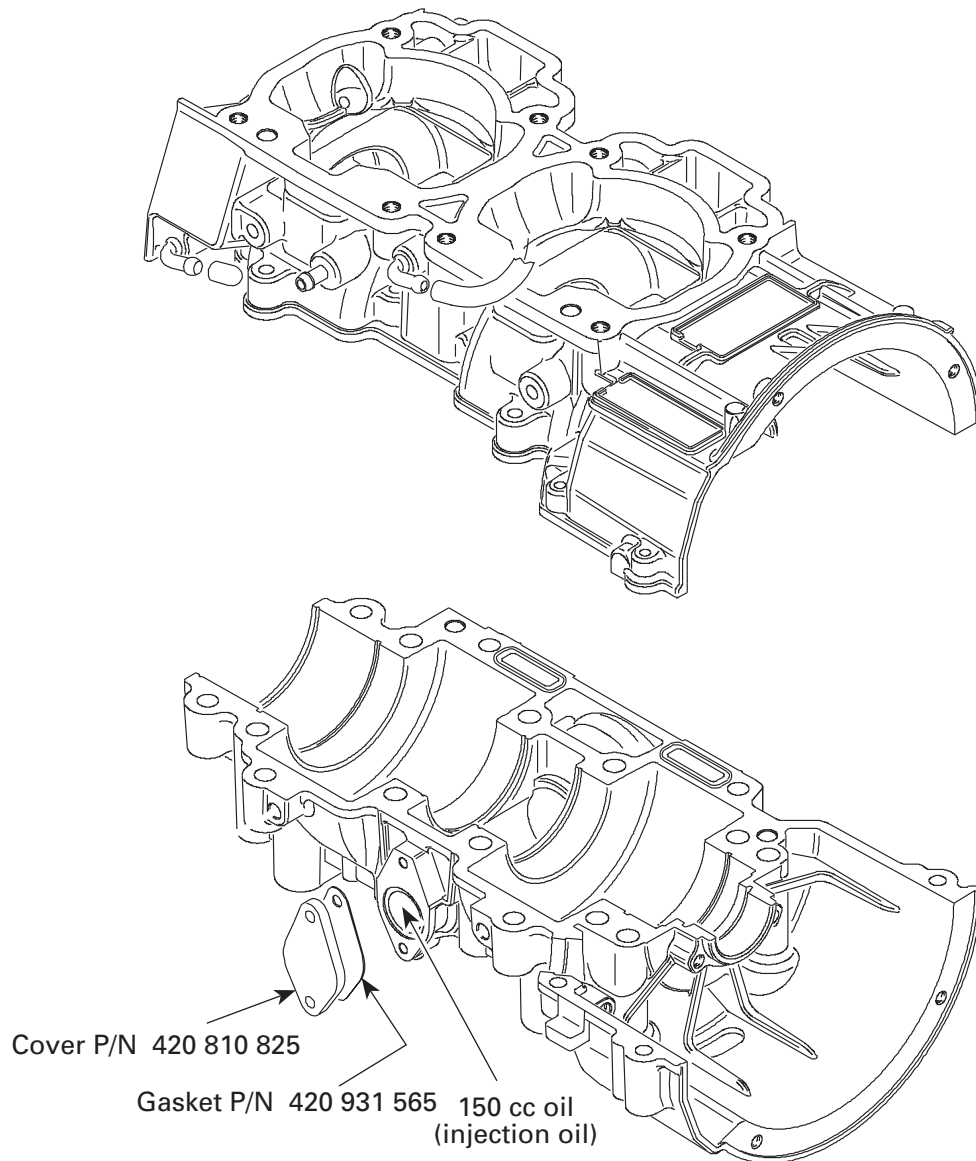

You must eliminate the two (2)
oil injection holes.
(use plugs or hoses)

WARNING: Note that the engine water pump gear oil cavity has to be filled with 150 mL of oil by removing oil pump block off plate and venting (opening empty bottle) then add 70 mL to bottle. (Best done when engine is on the work bench with the exhaust side facing work bench).

A33C0MS

SECTION 06 - 2004 800 MOD ENGINE KIT

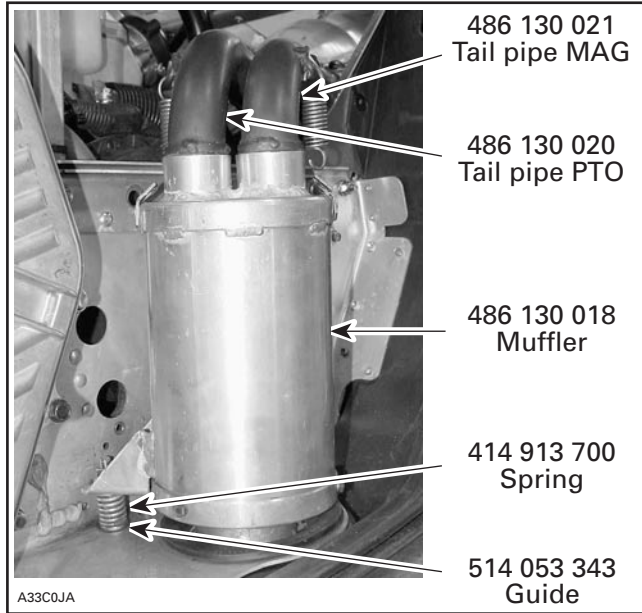
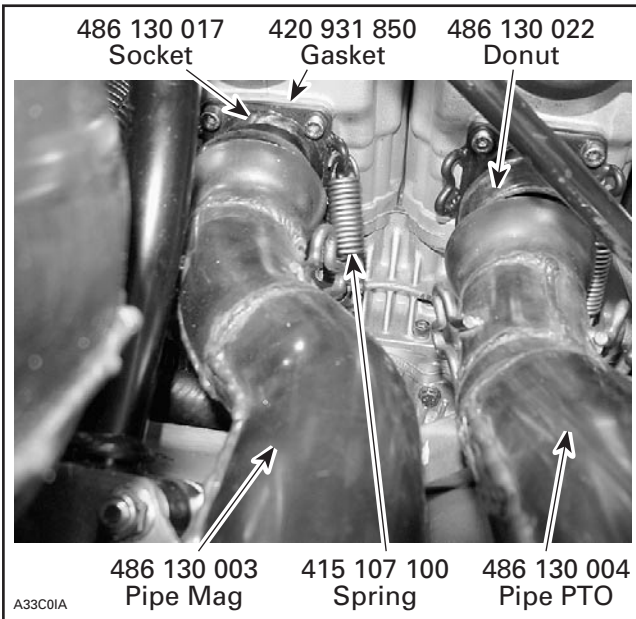
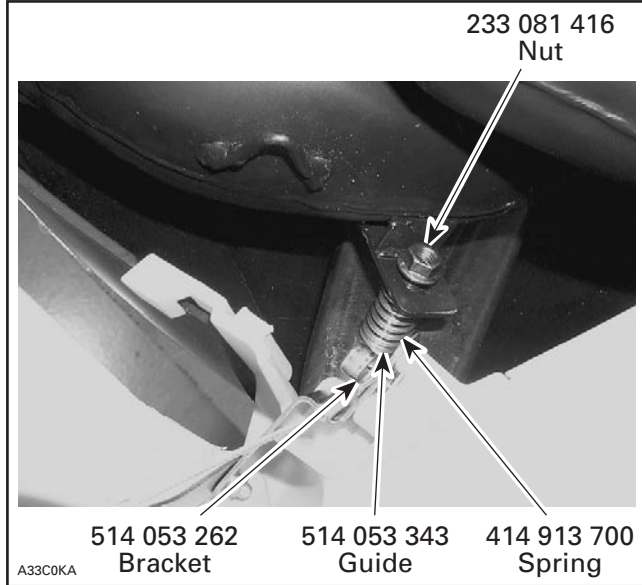
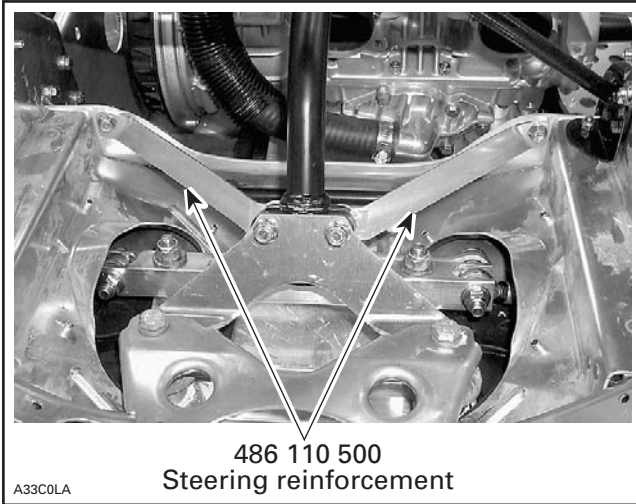

SECTION 06 - 2004 800 MOD ENGINE KIT

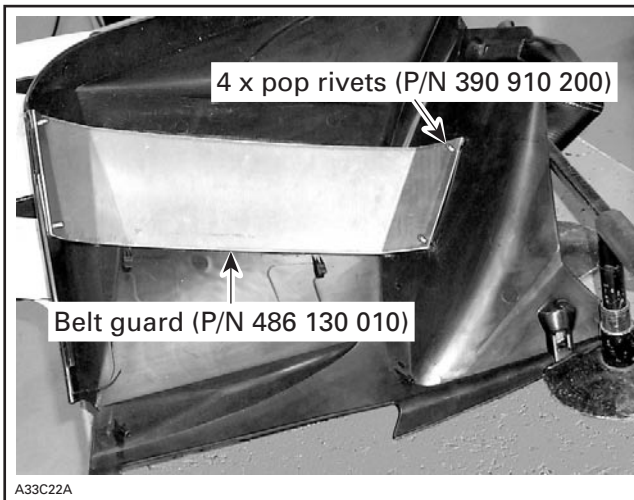
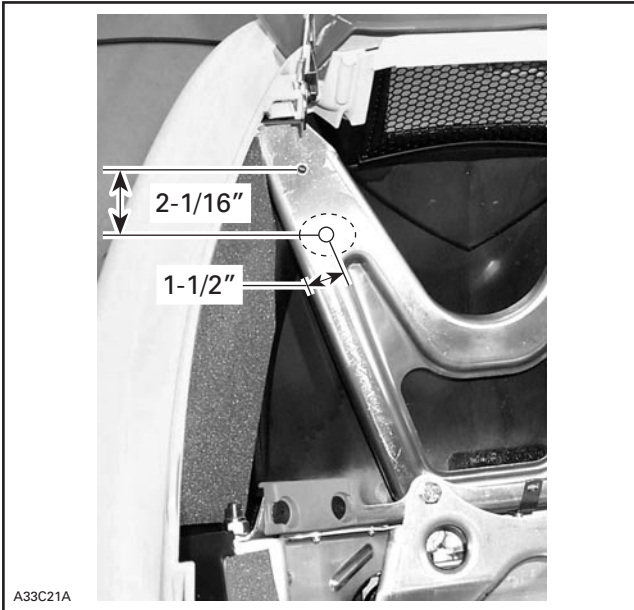

SECTION 06 - 2004 800 MOD ENGINE KIT

Tune Pipe Support

Make a new hole of 5/16 in. in the support hull. Insert the fastener of the tune pipe in that 5/16 in. hole. Make an other hole of 3/16 in. the support of the hull and install a new pop rivet to hold the fastener.

Tune Pipe Fastener Installation

Update tune pipe fastener installation. Use the black pop rivet 3/16 in. x 690 in.

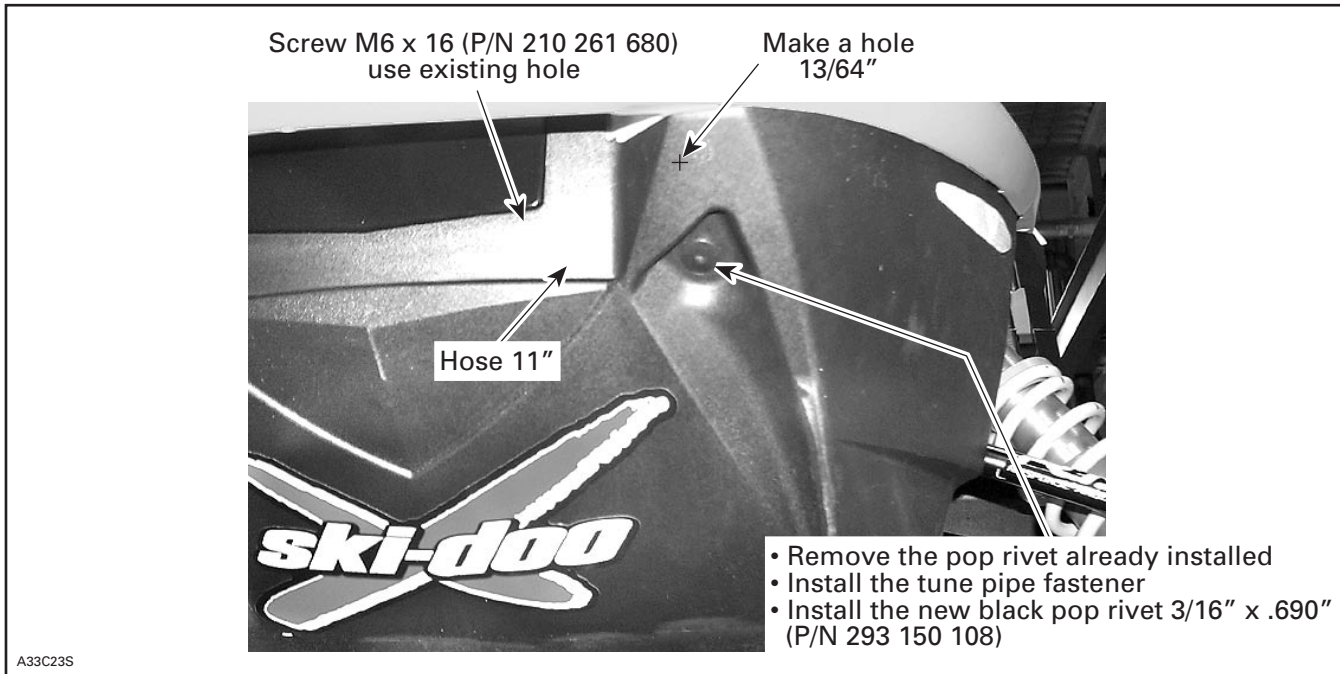

TABLE OF CONTENTS

| | |
|--|--------------|
| 2003 SKI-DOO MX Zx RACING TIP SHEET | 07-9 |
| SKI-DOO RACING, 7575 BOMBARDIER COURT, WAUSAU, WI 54401-8035 NUMBER: 01 NOVEMBER 11, 2002 | 07-9 |
| 2003 SKI-DOO MX Zx RACING TIP SHEET | 07-11 |
| SKI-DOO RACING, 7575 BOMBARDIER COURT, WAUSAU, WI 54401 NUMBER: 02 NOVEMBER 22, 2002 | 07-11 |
| 2003 SKI-DOO MX Zx RACING TIP SHEET | 07-12 |
| SKI-DOO RACING, 7575 BOMBARDIER COURT, WAUSAU, WI 54401 NUMBER: 03 AUGUST 01, 2003 | 07-12 |
| 2003 SKI-DOO MX Zx RACING TIP SHEET | 07-13 |
| SKI-DOO RACING, 7575 BOMBARDIER COURT, WAUSAU, WI 54401 NUMBER: 04 APRIL 2, 2003 | 07-13 |

SECTION 07 - 2003 MX Zx 440 INFORMATION

| 2003 OPTION PACKAGE COLOR | | MX Zx 440 RACING BLACK - YELLOW | | | |
|--|-----------|---------------------------------|---------|--------|----------|
| MODEL NUMBER | | CDN / U.S. : 2613 EUR : 2614 | | | |
| ENGINE | | | | | |
| Engine manufacturer | | Rotax | | | |
| Engine type no. | | 453 | | | |
| Lubrication type | | Premix | | | |
| Number of cylinders | | 2 | | | |
| Bore | mm in | 65.00 | | 2.559 | |
| 1 st oversize bore | mm in | N/A | | N/A | |
| 2 nd oversize bore | mm in | N/A | | N/A | |
| Stroke | mm in | 65.80 | | 2.591 | |
| Displacement | cc cu.in. | 436.70 | | 26.649 | |
| Cylinder Ø: (Piston to mm) | mm in | 64.88 | | 2.554 | |
| Compression ratio | | 14.8 | ± 0.5 | | |
| 1 st piston ring shape type | | Semi-trapez | | | |
| 2 nd piston ring shape type | | N/A | | | |
| Reed valve | (YES/NO) | YES | | | |
| Reed valve part number | | 420 924 810 | | | |
| RAVE system | (YES/NO) | YES | | | |
| Opening engine speed | RPM | 6500 - 7250 | | | |
| Spring part number | | 420 239 948 | | | |
| Spring color | | Gray | | | |
| Spring wire diameter | mm in | 1.00 | | 0.039 | |
| Spring free length | mm in | 38.00 | | 1.496 | |
| COOLING | | | | | |
| Cooling system type | | Liquid | | | |
| Thermostat opening temp. | °C °F | 42 | | 107.60 | |
| Cap opening pressure | kPa PSI | 90 | | 13.05 | |
| ENGINE | | | | | |
| Piston ring end gap | | | | | |
| New, min. | mm in | 0.400 | | 0.0157 | |
| New, max. | mm in | 0.550 | | 0.0217 | |
| Wear limit | mm in | 1.000 | | 0.0394 | |
| Ring/piston groove clearance | | | | | |
| New, min. | mm in | 0.040 | | 0.0016 | |
| New, max. | mm in | 0.080 | | 0.0031 | |
| Wear limit | mm in | 0.200 | | 0.0079 | |
| Piston/cylinder clearance | | | | | |
| New, min. | mm in | 0.100 | ± 0.016 | 0.0039 | ± 0.0006 |
| Wear limit | mm in | 0.200 | | 0.0079 | |
| Cylinder taper (max.) | | | | | |
| New, max. | mm in | 0.050 | | 0.0020 | |
| Wear limit | mm in | 0.100 | | 0.0039 | |
| Cylinder out of round (max.) | | | | | |
| New, max. | mm in | 0.010 | | 0.0004 | |
| Wear limit | mm in | 0.080 | | 0.0031 | |

SECTION 07 - 2003 MX Zx 440 INFORMATION

| 2003 OPTION PACKAGE COLOR | | MX Zx 440 RACING BLACK - YELLOW | |
|--------------------------------------|-------|--|---------------|
| MODEL NUMBER | | CDN / U.S. : 2613 EUR : 2614 | |
| Crankshaft balance factor | % | 42.5 % | |
| Cr. deflection (MAG side) | mm in | 0.050 | 0.0020 |
| Cr. deflection (center) | mm in | 0.080 | 0.0031 |
| Cr. deflection (PTO side) | mm in | 0.060 | 0.0024 |
| Crankshaft end play | | | |
| New, min. | mm in | 0.100 | 0.0039 |
| New, max. | mm in | 0.300 | 0.0118 |
| Wear limit | mm in | N/A | N/A |
| Con. rod big end axial play | | | |
| New, min. | mm in | 0.390 | 0.0154 |
| New, max. | mm in | 0.737 | 0.0290 |
| Wear limit | mm in | 1.200 | 0.0472 |
| Con. rod/piston pin clearance | | | |
| New, min. | mm in | 0.003 | 0.0001 |
| New, max. | mm in | 0.012 | 0.0005 |
| Wear limit | mm in | 0.015 | 0.0006 |
| Con. rod/crankpin clearance | | | |
| New, min. | mm in | 0.024 | 0.0009 |
| New, max. | mm in | 0.038 | 0.0015 |
| Wear limit | mm in | 0.050 | 0.0020 |
| CARBURETOR | | | |
| Carburetor manufacturer | | Mikuni | |
| Carburetor quantity x type | | 2 x TMX 34mm (Primer) | |
| | | PTO | MAG |
| Identification number | | TMX34-23 | TMX34-24 |
| Carburetor # | | 403 138 737 | 403 138 738 |
| Jet needle | | 6FIY4-59 | 6FIY4-59 |
| Clip position no. | | 4 | 4 |
| Needle jet | | Q-6 | Q-6 |
| Throttle slide cut-away | | 4.0 | 4.0 |
| Needle valve and seat | | 1.5 | 1.5 |
| Idle throttle slide position | | 1.4 | 1.4 |
| | | mm ± 0.1 | mm ± 0.1 |
| | | in ± 0.039 | in ± 0.039 |
| Main jet | | 0.055 | 0.055 |
| Idle (pilot) | | 390 | 390 |
| Idle air/mixture screw adj. | | 25.0 | 25.0 |
| Idle air/mixture screw adj. Ref | | 1.0 | 1.0 |
| Float level adjustment | | N/A | N/A |
| | | mm ± 0.1 | mm ± 0.1 |
| | | in ± 0.039 | in ± 0.039 |
| Cable/throttle slide adjustment | | At full throttle opening, cut-away lower edge must be equal or 1.0 (0.04) lower than of the venturi bore on engine side. | |
| Calibration engine speed | | ± 100 RPM | 8400 |
| Engagement engine speed | | ± 100 RPM | 5000 |
| Idle engine speed | | RPM | ± 200 1800 |

SECTION 07 - 2003 MX Zx 440 INFORMATION

| 2003 OPTION PACKAGE COLOR | | MX Zx 440 RACING BLACK - YELLOW | | | | |
|------------------------------|--------------|---|--------|-------------|----------|--|
| MODEL NUMBER | | CDN / U.S. : 2613 EUR : 2614 | | | | |
| ELECTRICAL SYSTEM | | | | | | |
| Ignition system manufacturer | | Nippondenso | | | | |
| Ignition system type | | C.D.I. | | | | |
| Ig. timing BTDC (Dynamic) | mm in | 3.140 | 0.1236 | at 3500 RPM | | |
| Stroboscopic timing | | 22.5° | | | | |
| Ig. timing BTDC (Static) | mm in | N/A | N/A | at 3500 RPM | | |
| Lighting system type | | AC-Generator | | | | |
| Lighting sys. output (AC) | W @ 6000 RPM | 290 | | | | |
| Nominal voltage output | V | 12 | | | | |
| Generator coil (low speed) | Ohm | 17.5 - 42.5 | | | | |
| Generator coil (high speed) | Ohm | 2.4 - 5.8 | | | | |
| Lighting coil | Ohm | 0.1 - 0.4 | | | | |
| Pick-up (trigger) coil | Ohm | 190 - 300 | | | | |
| High tension coil (pri.) | Ohm | 0.3 - 0.7 | | | | |
| High tension coil (sec.) | KOhm | 9.6 k to 14.4 k | | | | |
| Coils / MIN | mm | 0.700 | | 0.0276 | | |
| Magneto ring gap MAX | mm in | 1.850 | | 0.0728 | | |
| Trig. coil / MIN | mm in | 0.550 | | 0.0217 | | |
| Key mag. g. MAX | mm in | 1.450 | | 0.0571 | | |
| Spark plug manufacturer | in | NGK | | | | |
| Spark plug model no. | | BR 9 ES | | | | |
| Electrodes gap | mm in | 0.450 | ± 0.05 | 0.0177 | ± 0.0020 | |
| EXHAUST SYSTEM | | | | | | |
| Exhaust system type | | Single-tuned pipe to baffle muffler | | | | |
| TORQUE SPECIFICATIONS | | | | | | |
| Crankcase nuts/screws M6 | N•m lbf•ft | 9.0 | ± 1.0 | 6.6 | ± 0,7 | |
| Crankcase nuts/screws M8 | N•m lbf•ft | 29.0 | ± 1.0 | 21.4 | ± 0,7 | |
| Crankcase/engine sup. studs | N•m lbf•ft | 11.0 | ± 1.0 | 8.1 | ± 0,7 | |
| Crankcase/engine sup. nuts | N•m lbf•ft | 35.0 | ± 4.0 | 25.8 | ± 2.9 | |
| Cylinder head nuts / screws | N•m lbf•ft | 29.0 | ± 1.0 | 21.4 | ± 0,7 | |
| Water pump screws | N•m lbf•ft | 5.5 | ± 1.0 | 4.1 | ± 0,7 | |
| Magneto ring nut | N•m lbf•ft | 125.0 | ± 5.0 | 92.2 | ± 3,5 | |
| Exhaust manifold screws | N•m lbf•ft | 21.5 | ± 0.5 | 15.9 | ± 0,4 | |
| Intake manifold screws | N•m lbf•ft | 5.5 | ± 1.0 | 4.1 | ± 0,7 | |
| Magneto flywheel screws | N•m lbf•ft | 21.0 | ± 1.0 | 15.5 | ± 0,7 | |
| | | 29.0 | ± 1.0 | 21.4 | ± 1,5 | |
| Drive pulley retaining screw | N•m lbf•ft | *95.0 | | 70.068 | | |
| Shouldered pin nuts | N•m lbf•ft | 10.0 | | 7.376 | | |
| Ramp retaining screw | N•m lbf•ft | 10.0 | | 7.376 | | |
| Spring cover screws | N•m lbf•ft | 13.0 | | 9.588 | | |
| Nut of calibration bolt | N•m lbf•ft | 10.0 | | 7.376 | | |
| Steering arm/ski leg bolt | N•m lbf•ft | 25.0 | | 18.439 | | |
| Ball joints | N•m lbf•ft | 53.0 | | 39.091 | | |
| M. length unengaged threads | mm in | 15.0 | | 0.591 | | |
| Handlebar bolts | N•m lbf•ft | 26.0 | | 19.177 | | |
| ADDITIONAL INFORMATION | | *Torque 80 to 100 N•m (59-74 lbf•ft), 5 "accel./brake" cycles, torque 90 to 100 N•m (66-74 lbf•ft). | | | | |

SECTION 07 - 2003 MX Zx 440 INFORMATION

| | | | | | |
|------------------------------------|-----------------------|--|--------|--------|---------|
| 2003 OPTION PACKAGE COLOR | | MX Zx 440 RACING BLACK - YELLOW | | | |
| MODEL NUMBER | | CDN / U.S. : 2613 EUR : 2614 | | | |
| POWER TRAIN (DRIVE PULLEY) | | | | | |
| Drive pulley manufacturer | | IBC Canada | | | |
| Drive pulley type | | Cushion drive T.R.A. | | | |
| Drive pulley part number | | 417 222 421 | | | |
| Drive pulley diameter | mm in | 210.00 | | 8.268 | |
| Ramp identification | | 296 | | | |
| Ramp quantity | | 3 | | | |
| Ramp part number | | 417 005 296 | | | |
| Pressure lever part number | | 417 222 383 | | | |
| Roller part number | | 417 003 900 | | | |
| Roller quantity | | 3 | | | |
| Roller pin type | | 10.3 g. Threaded | | | |
| Roller pin part number | | 417 222 625 | | | |
| Drive pulley spring part number | | 415 019 800 | | | |
| Spring stripes colors | | blue | | | |
| Drive pulley spring length | mm in | 120.00 | | 4.724 | |
| Calibration screw position no. | | 5 | | | |
| Engagement speed | ± 100 RPM | 5000 | | | |
| POWER TRAIN (DRIVEN PULLEY) | | | | | |
| Driven pulley type | | FORMULA Roller | | | |
| Driven pulley part number | | Type | | | |
| Driven pulley diameter | mm in | 417 126 494 | | 10.709 | |
| Driven pulley spring number | | 272.00 | | | |
| Driven pulley spring color | | 414 558 900 | | | |
| Preload at external dia. MIN | kg ± 0.7 lbf ± 1.5 | Beige | | | |
| Driven pulley cam angle | deg. | 7.00 | | | |
| Cam part number | | 15,432 | | | |
| Pulleys center distance | mm in | 417 126 737 | ± 0.5 | 10.138 | ± 0.020 |
| "Z" distance | mm in | 257.50 | | 0.689 | |
| (Without torque rod preload) | | 17.50 | | | |
| "X" offset | mm in | | ± 0.5 | 1.398 | ± 0.020 |
| "Y-X" difference | mm in | 35.50 | ± 0.75 | 0.059 | ± 0.030 |
| | | 1.50 | | | |
| DRIVE BELT | | | | | |
| Drive belt part number | | 414 860 700 | | | |
| Drive belt width | mm in | 35.30 | | 1.390 | |
| Drive belt outside perimeter | mm in | 1107.90 | | 43.618 | |
| Wear limit | mm in | 32.50 | | 1.280 | |
| Drive belt def. (+/- .197") | mm in | 32.00 | | 1.260 | |
| Drive belt adjustment force | kg lbf | 11.34 | | 25.000 | |
| Small sprocket number of teeth | | 21 | | | |
| Small sprocket part number | | 504 152 044 | | | |
| Large sprocket number of teeth | | 43 | | | |
| Large sprocket part number | | 504 148 600 | | | |
| Gear ratio | | 2.05 | | | |
| Chain type | | Silent | | | |
| Chain part number | | 504 151 910 | | | |
| Chain pitch | mm in | 9.525 | | 0.375 | |
| Chain, number of links | | 74 - 15 | | | |

SECTION 07 - 2003 MX Zx 440 INFORMATION

| | | | |
|-----------------------------------|-----------------|--|---|
| 2003 OPTION PACKAGE COLOR | | MX Zx 440 RACING BLACK - YELLOW | |
| MODEL NUMBER | | CDN / U.S. : 2613 EUR : 2614 | |
| Drive sprocket pitch diameter | mm in | 181.5 | 7.146 |
| Drive sprocket number of teeth | | 9 | |
| FRONT SUSPENSION | | | |
| Front suspension type | | R.A.S. A-Arm | |
| Front suspension travel | mm in | 242.00 | |
| Sway bar type | | Sway bar (Formed Shape) | 9,528 |
| Front susp. shock abs. qty & type | | *1 .G. T/A Remote reservoir | .5 in dia |
| Shock absorber part number | | 505 070 952 | R.H. 505 070 953 |
| Standard spring part number | | 505 071 200 | 105 lb/in LH |
| Optional spring(s) part number(s) | | 486 130 023 | 90 lb/in |
| | | 486 130 024 | 120 lb/in |
| REAR SUSPENSION | | | |
| Rear suspension type | | SC 10 III | |
| Rear suspension flat travel | mm in | 369.00 | 14.528 |
| Rear suspension max. travel | mm in | 369.00 | 14.528 |
| Wheels quantity & diameter | mm in | 2 x 102 mm (4.00") 2 x 165 mm (6.50") 6 x 135 mm (5.31") 3 x 165 mm (6.50") | |
| Stroke limiter type | | Stopper strap | |
| Stroke limiter standard position | | 2 / 7 | |
| Front arm shock abs. qty & type | | *1 .G. T/A Remote reservoir | |
| Front arm shock abs. part number | | 503 189 972 | |
| Standard front spring part number | | 503 190 296 / 503 190 299 | |
| Optional spring(s) part number(s) | | — — | |
| Front preload adjustment type | | — | |
| Rear arm shock abs. qty & type | | *1 T/A Remote reservoir C-36 | |
| Rear arm shock abs. part number | | 503 189 974 | |
| Standard rear spring part number | RH LH | 503 189 902 503 189 904 | |
| Optional spring(s) part number(s) | RH LH | HARD 503 189 992 503 189 994 | SOFT 503 189 947 503 189 948 |
| Rear preload adjustment type | | 4 positions cam on shock abs. | |
| BRAKE SYSTEM | | | |
| Brake type | | Hydraulic, disc, self-adjust. | |
| Brake lining material | | FERIT # 451 | |
| Brake lining surface | cm ² | 2 X 12.4 | |
| Minimum lining thickness | mm in | 1.00 | 0.039 |

SECTION 07 - 2003 MX Zx 440 INFORMATION

| 2003 OPTION PACKAGE COLOR | | MX Zx 440 RACING BLACK - YELLOW | |
|---|----------|--|------------|
| MODEL NUMBER | | CDN / U.S. : 2613 EUR : 2614 | |
| TRACK | | | |
| Track # & profile height | mm in | 504 152 200 | 41.3 1.625 |
| Track construction | | Rubber, polyester reinforced | |
| Track nominal width | mm in | 381.00 | 15.000 |
| Track nominal length | mm in | 3074.00 | 121.024 |
| Track lug pitch distance | mm in | 63.90 | 2.516 |
| Number of track pitches | | 48.00 | |
| Track deflection | mm in | 30.00 | 1.181 |
| MIN/MAX | mm in | 35.00 | 1.378 |
| Track adjustment force | kg lbf | 7.30 | 16.094 |
| GENERAL SPECIFICATIONS | | | |
| Vehicle overall length | mm in | 2787.00 | 109.724 |
| Chassis overall length | mm in | 2062.00 | 81.181 |
| Vehicle overall width | mm in | 1217.00 | 47.913 |
| Vehicle overall height | mm in | 1280.00 | 50.394 |
| Ski stance (Carbides to carbides) | mm in | 1080.00 | 42.520 |
| Ski overall length | mm in | 997.00 | 39.252 |
| Ski width | mm in | 133.00 | 5.236 |
| Total toe-out (raised vehicle) | mm in | 0.00 | — |
| Camber angle | deg. | 0 | |
| Dry vehicle mass | kg lb | 199 | 438 |
| VEHICLE ELECTRICAL SYSTEM | | | |
| Headlamp bulb hi/low beam | W | 60/55 | H-4 |
| Tail/stop lamp bulb | W | 8/27 | |
| Tachometer bulb | W | 2 x 3 | |
| Lamp-pilot (high beam) | W | 0.5 | |
| Lamp-pilot (temperature) | W | 0.5 | |
| Heat. throttle handle (hi/low) | W | 7 / 5 | |
| Heated grips hi/low (driver) | W | 40 / 20 | |
| LIQUIDS SPECIFICATIONS | | | |
| Fuel tank (SAE J288a rated) | L US gal | 20 | 5.3 |
| Recommended fuel type | | Premium unleaded | |
| Minimum octane number (R+M)/2 | | 92 | |
| Premix fuel/oil ratio | | 33 : 1 | |
| Recommended mixing oil | | Bombardier Synthetic oil (FORMULA XP-S II) | |
| Chaincase oil capacity | mL US oz | 250 | 8.5 |
| Oil level height | mm in | Maximum mark on dipstick | |
| Recommended chaincase oil | | Bombardier synthetic chaincase oil | |
| Cooling system capacity | L US oz | 4.3 | 145.4 |
| Ethylene-glycol concentration | % vol. | 50 / 50 | |
| Brake fluid reservoir | mL US oz | | |
| Recommended brake fluid | | 60 | 2.0 |
| | | Brake fluid SRF (DOT 4) | |

SECTION 07 - 2003 MX Zx 440 INFORMATION

| 2003 OPTION PACKAGE COLOR | | MX Zx 440 RACING BLACK - YELLOW | | |
|--|--|---------------------------------|-----|---------------------------|
| MODEL NUMBER | | CDN / U.S. : 2613 EUR : 2614 | | |
| STANDARD/OPTIONAL EQUIPMENT | | | | |
| Electric starter kit | | N/A | | |
| Gauge (Tachometer (White facia)) | | STD | | |
| Gauge (Speedometer (White facia)) | | STD | | |
| Gauge (Fuel (electric) (White facia)) | | N/A | | |
| Gauge (Temp. (electric)(White facia)) | | | OPT | 861 507 900 |
| Heated grips (driver) | | STD | | |
| Heated throttle lever | | STD | | |
| Power Outlet Kit | | N/A | | |
| Heated visor quick connect kit | | N/A | | |
| Mirrors (kit) | | | OPT | 861 780 800 |
| Seat (1 + 1) | | N/A | | |
| Luggage rack | | N/A | | |
| Hitch (hook type) | | N/A | | |
| Hitch (tongue type) | | N/A | | |
| Quick adjustment kit | | | OPT | 860 306 500 |
| Bridge & fasteners plastic ski (Flex) | | STD | | |
| Bridge & fasteners plastic ski (Precision) | | | OPT | 860 507 700 |
| Bridge & fasteners plastic ski (Mountain) | | N/A | | |
| Ski soles Black B-160 (FLEX) | | STD | | |
| Ski soles Black B-160 (Precision) | | | OPT | 505 070 727 |
| Ski soles Yellow B-190 (Precision) | | | OPT | 505 070 831 |
| Ski soles Red B-212 (Precision) | | | OPT | 505 070 832 |
| Ski soles Black B-160 (Mountain) | | N/A | | |
| Ski runner | | | OPT | 505 069 300 |
| Ski runner (With Carbides) | | STD | | |
| Skid plate fasteners kit / Rivets | | | OPT | 861 764 600 / 861 770 300 |
| Skid plate black | | | OPT | 502 006 671 |
| Skid plate orange | | | OPT | 502 006 672 |
| Skid plate yellow | | | OPT | 502 006 673 |
| Windshield (Low) | | STD | | |
| Windshield (Medium) | | N/A | | |



2003 SKI-DOO MX Zx RACING TIP SHEET

SKI-DOO RACING, 7575 BOMBARDIER COURT, WAUSAU, WI 54401-8035
NUMBER: 01 NOVEMBER 11, 2002

⚠ WARNING

This information relates to the preparation and use of snowmobiles in competitive events. Bombardier, Inc. and Bombardier Corporation disclaim liability for all damages and/or injuries resulting from the improper use of the contents. We strongly recommend that these modifications be carried out and/or verified by a highly skilled professional racing mechanic. It is understood that racing or modifications of any Bombardier made snowmobile voids the vehicle warranty and that such modifications may render use of the vehicle illegal in other than sanctioned racing events under existing federal, provincial and state regulations.

NUMBER PLATE - 2003 440 REV & ROLLING CHASSIS

New regulations are being implemented this year regarding the size of numbers to be used during competition. The new rule requires 8" high black numbers on a white background located on both sides of the sled. The OEM white number plate is not large enough to meet those requirements. To meet the new requirements, enlarge the white area upward past the body panel curve and then place your number in the area. You may want to install an actual number plate in that area by fastening it to the side panel.

FUEL OCTANE SWITCH - 2003 440 REV

The wires from the fuel octane switch were inadvertently switched on some units during production. Locate the 6 pin connector from the octane switch. Identify the GREY wire in position 6 and the GREY/VIOLET wire in position 4. Using a small screwdriver, remove the GREY and the GREY/VIOLET wires from the connector. Reinstall the GREY wire in position 4 and the GREY/VIOLET wire in position 6.

LOWER GEAR BOLT - 2003 440 REV & ROLLING CHASSIS

During production, an excess amount of Loc tite was used to install the bolt securing the lower gear. To correct this, heat up the bolt to release the Loc tite, remove the bolt and gear, clean the bolt threads and splines of the shaft and gear, re-install the bolt using a small amount of Loc tite.

CARBURETOR VENT LINES - 2003 440 REV

The vent line from the carburetors to the air box is too long and allows fuel to collect in the low areas of the line when the side panel is closed. To correct this, open left side panel fully, remove vent line from air box, lightly pull the vent line until all slack is taken up, cut approx. 8 inches off the end of the line. Reconnect vent line to air box. The correct length of vent line is when you open the side panel, a slight pull should be on the line. Do not cut too much, otherwise you will have to replace the line. This will prevent fuel from building up in the line, restricting the airflow in the line and possibly changing the jetting.

SECTION 07 - 2003 MX Zx 440 INFORMATION

ENGINE SPECS - 2003 440 REV

At the Midwest Race School, the combustion chamber volumes and squish measurement were presented incorrectly. The values given at the school were for the low compression head inserts. The correct values for the high compression head inserts are as follows;

Installed Volume 18.0 + 1.5cc

Flat Plate Volume 17.6 + .9 cc

Squish mm 1.16 + .3 mm

Squish in. .046 + .012 in

ROLLING CHASSIS & 800 MOD ENGINE KIT

When installing the 800 Mod engine kit into the rolling chassis, disconnect the heat sensor and timing switch from the MPEM.

These 2 items are not required.

The rolling chassis comes with the driven clutch installed and 5 shim washers behind it. After installing the engine, perform proper clutch alignment to insure correct clutch offset.

The rolling chassis is equipped with a jetting chart located on the belt/clutch guard, this chart is for the 440 cc engine and should not be used with the 800 Mod engine kit.

SNOW FLAP - 2003 440 REV & ROLLING CHASSIS

Some race circuits are requiring the snow flap to touch the ground when the rider is NOT on the sled. A flap extension is required. Rubber material is not allowable for an extension, it must be made of rigid plastic and securely fastened by rivets or small bolts to prevent it from coming loose.

SKI LOOPS - 2003 440 REV & ROLLING CHASSIS

Due to the change in rules, the stock ski loop does not meet the new rules. 2 options are available. Option 1, is to replace the entire ski with a set that does meet the new rules. Option 2 is to replace the ski loop. Legal loops can be purchased from the Ski Doo Parts Support Truck, or can be ordered from Warnert Enterprises, 728 8th Ave. S., Sauk Rapids MN 56379. By phone, call 320 251 4764.

If you have any information you would like to be included in future TIP Sheets, please contact me at;

Tom Lawrence
Racing Coordinator
7575 Bombardier Court
Wausau WI. 55401
Phone: 715-848-4971
Fax: 715-847-6879



2003 SKI-DOO MX Zx RACING TIP SHEET

SKI-DOO RACING, 7575 BOMBARDIER COURT, WAUSAU, WI 54401
NUMBER: 02 NOVEMBER 22, 2002

⚠ WARNING

This information relates to the preparation and use of snowmobiles in competitive events. Bombardier, Inc. and Bombardier Corporation disclaims liability for all damages and/or injuries resulting from the improper use of the contents. We strongly recommend that these modifications be carried out and/or verified by a highly skilled professional racing mechanic. It is understood that racing or modifications of any Bombardier made snowmobile voids the vehicle warranty and that such modifications may render use of the vehicle illegal in other than sanctioned racing events under existing federal, provincial and state regulations.

DRIVEN CLUTCH - 440 REV & ROLLING CHASSIS

Remove the cam from the driven clutch and, using a file, file a small bevel angle on the outside edge of the cam angle. This is to prevent the cam from contacting the backing washer behind the roller.

REAR SHOCK MOUNTS - 440 REV & ROLLING CHASSIS

After a short breakin period, check the torque of the rear shock mounting bolts. Retorque to 22 - 24 ft lbs. Check often and retorque if necessary.

CARBURETION CALIBRATION - 800 OPEN MOD KIT

If you are experiencing a low to midrange richness, move the needle clip to first (#1) position from the top.

CARBURATION CALIBRATION - 440 REV

The 440 REV comes stock with very rich jetting, rejet according to the jet chart located on the belt guard.

FRONT SUSPENSION BALL JOINTS - 440 REV & ROLLING CHASSIS

Regularly check the torque of the front suspension ball joints. Torque to 44 - 48 ft lbs.

HANDLEBAR PAD

To prevent loss of the handlebar pad, use cable ties to securely fasten to handlebar.

REAR SUSPENSION SPRINGS - 440 REV & ROLLING CHASSIS

For drivers lighter than 140 lbs, remove the rear stock springs and install the soft spring option, part number 503 189 947 and 503 189 948. Turn both the low and high speed adjusters to 1-1/2 turns out.

IDLER WHEELS - 440 REV & ROLLING CHASSIS

To prevent front arm interference when installing idler wheels in the rear suspension, the front set of wheels must be mounted on the inside the rails. The second set (middle) must be on the out side of the rails, and the third set (rear) must be mounted on the inside.

SKI ALIGNMENT - 440 REV & ROLLING CHASSIS

Check ski alignment and adjust from 0 to 1/8" toe out.



2003 SKI-DOO MX Zx RACING TIP SHEET

SKI-DOO RACING, 7575 BOMBARDIER COURT, WAUSAU, WI 54401
NUMBER: 03 AUGUST 01, 2003

⚠ WARNING

This information relates to the preparation and use of snowmobiles in competitive events. Bombardier, Inc. and Bombardier Corporation disclaims liability for all damages and/or injuries resulting from the improper use of the contents. We strongly recommend that these modifications be carried out and/or verified by a highly skilled professional racing mechanic. It is understood that racing or modifications of any Bombardier made snowmobile voids the vehicle warranty and that such modifications may render use of the vehicle illegal in other than sanctioned racing events under existing federal, provincial and state regulations.

SHOCKS - 2003 440 REV AND ROLLING CHASSIS

It is highly recommended to check the torque of the retaining nut that holds the valve stack and piston in place when rebuilding or cleaning any of the shocks on the unit. The Race Manual incorrectly lists the torque spec as 8-10 ft lbs. The proper torque specification is 18-20 ft lbs.

RACE SUPPORT TRUCK

The Ski Doo Race Support Truck will be at all WSA National Sno X events and other selected events thruout the winter. To order parts from the support truck, call 320-251-2882 or fax your order to 320-251-3733.



2003 SKI-DOO MX Zx RACING TIP SHEET

**SKI-DOO RACING, 7575 BOMBARDIER COURT, WAUSAU, WI 54401
NUMBER: 04 APRIL 2, 2003**

⚠ WARNING

This information relates to the preparation and use of snowmobiles in competitive events. Bombardier, Inc. and Bombardier Corporation disclaims liability for all damages and/or injuries resulting from the improper use of the contents. We strongly recommend that these modifications be carried out and/or verified by a highly skilled professional racing mechanic. It is understood that racing or modifications of any Bombardier made snowmobile voids the vehicle warranty and that such modifications may render use of the vehicle illegal in other than sanctioned racing events under existing federal, provincial and state regulations.

2004 MX Z X 440, ROLLING CHASSIS, 800 MOD ENGINE KIT APPLICATION FORM

To get a downloaded version of the 2004 Application Form, go to www.ski-doo.com, click on the Racing tab, then select X Team Home. This is a PDF file which includes the X Team logo, which causes the form to take extra time to download. Be patient. You can also receive the form on a Microsoft Excel spreadsheet from the Ski Doo Race Dept. by emailing tom.lawrence@recreation.bombardier.com. If you do not have Excel capabilities, email Tom and he will fax a form to you. One last method to obtain a form is through your local Ski Doo Dealer. Deadline is April 15th 2003

INCORRECT SHOCK PART NUMBERS

Please make the following Part Number corrections on page 3-28 of the 2003 Racing Handbook regarding the 2003 MXZx 440 HPG C-36 Shock Part List. All the 486 130 xxx numbers must be changed to 486 140 xxx. We regret any inconvenience this may have caused.

C-36 SHOCK HIGH AND LOW SPEED COMPRESSION ADJUSTERS

A reminder when adjusting the High and Low Speed compression adjusters, They must be a minimum of one turn open for the shock to operate properly and to avoid failure.

RACER FEEDBACK AND COMMENTS

With the race season almost over, the Ski Doo Race Dept. is looking for feedback regarding the 440 MX Z X REV, Rolling Chassis and 800 Mod engine kits that were allocated this past year. We would appreciate your comments to improve for the upcoming years. Email your comments to tom.lawrence@recreation.bombardier.com or fax to 715-847-6879.

2004 RACE SCHOOLS

Plans are currently being made to once again offer Race Schools this upcoming fall. The Midwest School will once again be held in the Minneapolis MN area, The Eastern School will be in the Syracuse NY area, AND, we are planning a Hillclimb/Sno X School for the Western area. Details, dates and locations will be released later this summer.

Everyone, have an enjoyable summer!

TABLE OF CONTENTS

| | |
|---|-------|
| SNO CROSS..... | 08-2 |
| HILLCROSS | 08-2 |
| HILL CLIMBING..... | 08-3 |
| DRAG RACING (ICE AND GRASS) | 08-3 |
| SPEED RUNS | 08-5 |
| OVAL RACING..... | 08-5 |
| SUGGESTED SPARE PARTS..... | 08-7 |
| EQUIVALENT WEIGHTS AND MEASURES CHART | 08-9 |
| FUEL/OIL RATIO CHARTS | 08-10 |
| STOCK CLASS PREPARATION | 08-15 |
| TECHNICAL DATA..... | 08-16 |

SECTION 08 - COMPETITION PREPARATION

These are general guide lines for preparing a stock REV chassis for various forms of competition. Refer to the appropriate section of the book for more detailed information and tuning components.

SNO CROSS

Chassis

- The ideal chassis to use is the MX Zx 440 REV chassis. This chassis is specifically designed for Sno Cross racing.

Front Suspension

- The 2004 MX Zx 440 REV comes equipped with remote adjustable shocks for both high and low speed compression. Use the low speed shock adjusters to control the small or slow bumps and adjust the high speed adjusters to control big or fast bumps to prevent the suspension from bottoming out.
- Stock spring rate is 18.4 N/mm (105 lbf/in), and there is lighter and stiffer springs available. Adjust spring preload between 0 and 13 mm (0 in and 1/2 in) of suspension ride in (sag) when the rider is standing in race position. If you have to adjust the spring pressure more than 38 mm (1-1/2 in) of preload on the shock, you may want to change to a stiffer spring.
- A 13 mm (1/2 in) diameter anti roll bar comes standard. Many racers choose to remove the anti-roll bar. If you remove the bar, make sure to cover the holes in the bulkhead area with aluminum or plastic plate as to prevent snow from entering. If you wish to use a larger bar, the 600 & 800 REV use a 16 mm (5/8 in) diameter. Those are the only options available to date.

Center Suspension

- Set spring pressure to light settings and adjust shocks adjusters to control high and low compression to prevent bottoming out. If the rear of the sled wants to pass the front while in the air, reduce spring pressure and/or shock compression.

Rear Suspension

- Again, the rear shock has external adjusters for high and low speed compression. Set adjusters so the suspension does not bottom out. This adjustment must be for different courses.

- Adjust spring pressure, with the rider in place, so the ACM block is in the center of the coupling window. Stiffer and softer springs are available. Adjust the ACM block to control the amount of weight transfer according to conditions.

Fuel and Carburetion

- Recommended fuel octane is minimum 100. Be aware that only unleaded fuel is legal to use. Use the jetting chart on the belt guard as a guideline. When installing 0.3 mm (.012 in) base gasket, you are able to increase octane and performance. Higher altitude requires lower fuel octane. Example, 1829 m (6000 feet), maximum 100 octane.

Skis

- The ski loops do not meet ISR guidelines, therefore modification to the loops must be made before using them in competition. The loop must be rapped and secured with a foam or rubber tube to meet the 25 mm (1 in) minimum width and also fold over the front of the ski tip and secured. Failure to do so may result in disqualification.

Snow Flap

- Some circuits are requiring that the snow flap be long enough to touch the ground when the rider is not on the sled. An extension may be required. Best extension material is plastic sheet or another snow flap.

HILLCROSS

Special Rules

- The stud rule is the same as Sno Cross. Care must be taken when installing studs as not to place them where they will cause damage to heat exchanger or tunnel. Tunnel protectors of the correct height are required.
- Most circuits have different classes from Stock to Modified, be sure to check with the Race Circuit for specific rules and guidelines regarding each class.

Suspension

- Use Sno Cross spring and shock set up.

Track

- Best performance and speed is achieved by installing a 136" x 15" with 1.75" lug height.
- 136" Track extension kits are available in limited quantities. Contact Ski-Doo Race Dept. for availability and information.

Transmission

- Clutch setups will be similar to Sno Cross. Due to higher speeds than Sno Cross, an increase in gearing is required, depending on length and steepness of course.

HILL CLIMBING

Front Suspension

- Use soft springs. You want the skis to compress very easily and not transmit any upward force into the chassis.
- Use minimal compression and medium rebound dampening in the shock absorbers and, the gas pressure can be reduced to 1379 kPa 200 PSI.

Center

- Use medium spring pressure. You need some track pressure for traction but the front arm must be able to compress easily to absorb bumps.
- Use minimal compression and medium rebound dampening in the shock absorbers.
- The limiter strap should be fairly short to keep front end lift to a minimum. Two to three inches of lift is plenty. A balance must be maintained between having enough traction and keeping the front end down for steering.

Rear Suspension

- Spring pressure should be kept firm in order to reduce weight transfer and help keep the front end down on the ground.
- Medium amount of compression and enough rebound to control the stiffer spring settings to prevent the rear of the machine from "pogoing".

Track

- Use a "finger" type track with a 1.75" to 2.00" lug height profile. Beginning of season or fresh snow, use a track with a 1.75" lug height and later in the year when the hill has a lot of ice, use a 2.00" lug height track.
- Use a 144" X 15" track for best performance.
- For information regarding chassis extension kits, contact Ski-Doo Race Dept.
- Check with the race organization for rules regarding changing of tracks.

Transmission

- Good backshifting is important. Use a few pounds more than normal preload on the driven pulley.
- Adjust the TRA to maintain optimum RPM.

Driving Style

- Contrary to popular belief, constant full throttle is not always the fastest way to the top. Use your thumb to adjust for the conditions. Sometimes you need to back out of it to keep the track from spinning excessively. You need to keep your momentum up but you must keep the sled on the ground so your track is hooked up and the skis can steer you around any obstacles.

DRAG RACING (ICE AND GRASS)

Special Rules

- Snow flap must be retained by 3 mm (1/8 in) diameter cable.
- Double limiter straps are required by many organizations.

Front Suspension

- Lower the ride height by installing shorter springs, limiter straps or spacer inside the shock to limit suspension travel. Maximum shock length is 360 mm (14.7 in) with 15 mm (.59 in) of spring preload.
- Trim the rubber blocks under the ski legs to reduce and adjust the amount of heel pressure on the ski.
- Use steel runners on the grass and stock trail carbide runners on the ice.

SECTION 08 - COMPETITION PREPARATION

Center

- Use stock springs but limit suspension travel with limiter straps or stops to 76 mm (3 in), measured from the front arm to bumper stop.
- Shorter limiter straps will be required. On grass, more weight transfer can be used to keep the weight off the skis. On ice, run the limiter very short to keep ski lift to a minimum.

Rear Suspension

- Replace stock springs with (P/N 486 099 100 RH) and (P/N 486 099 300 LH). These springs have a higher spring rate but softer preload. Limit suspension travel by straps or stops to 102 mm (4 in), measured between the rear arm and bumper stop. Adjust the ACM coupling block to full couple.
- Grass: Soften preload to help weight transfer and keep the skis from dragging.
- Ice: Use a lot of preload to help keep the front end down for better top speed at the end of the chute.
- Remove slider shoes (HyFax). Add idler wheels of correct size to prevent track from contacting rails

Traction

- Most rules limit maximum stud height to 19 mm (3/4") over the tallest part of the track. Taller tunnel protectors will be required.
- Generally, fewer studs are required on grass than on ice. Also, less studs are needed on good, thick sod or hard clay. More studs will be needed on loose grass, dirt and sand.
- Grass: Four steel picks per bar (4 x 48 pitches on 121" track = 192 studs). Large horsepower machines may need more studs. Exchange some picks for grass hooks on looser track surfaces. Use "chisel" style studs. They have a wider pro-file but are still sharp on the ends.
- Ice: Stud quantity is directly related to horsepower on the ice. Up to about 80 HP, 4 to 5 ice picks per pitch should be used for a total of 200-250 studs. 80 to 105 HP should need 6 to 7 picks per pitch for a total of 300-350 studs. Over 110 HP will require 7 to 8 picks per pitch and possibly hooker plates welded to the track guides.

NOTE: The installation of hooker plates will require modification to the tunnel protection system and should be approached with caution.

- 51 mm (2 in), two hole angled aluminum backer plates should be used when many studs are required. They should form the basis of your stud pattern with single, square, flat or angled backer plates used in between.
- Studs should be placed so the pattern does not repeat itself for 4 to 6 pitches.

Transmission

- Gear for about 10% over the actual speed you will run in the race. On grass, your upper sprocket should be about two teeth smaller than on the ice.
- Always stay with the same belt type and size, belt deflection, and center to center distance. Have several belts of the same size broken in and ready to race. Don't test with one belt and then throw on a new one for race day.
- Keep the clutches clean! The pulley faces and belt should be lightly sanded and wiped down with acetone before every run. Excessive pulley heat indicates belt slippage and you may need to recalibrate your clutch to squeeze the belt harder.
- Torque is what overcomes resistance to rolling. Normally peak torque is about 200 to 300 RPM below peak horsepower. When accelerating at the start of a race, clutch to peak torque and let the RPM climb to max horsepower by the end of the run.
- Tune your clutches so that you run best for the final which means everything will be heat soaked. If your sled requires different set ups between early runs when everything is cold and later runs, know what to change and when to change it. Test under a variety of conditions so you are prepared for any track and race conditions.

Cooling

- Install a pair of hydraulic quick couplers in the coolant hoses at a convenient location on the sled. Make a cooling cart using a cooler filled with ice and several winds of copper tubing inside (or another type of heat exchanger) connected to an electric pump and another set of quick couplers. Connect your sled to this mobile refrigerator between runs to circulate coolant through the system and cool the engine down. Cool the engine to the same temperature every time so your runs are consistent.

For more drag racing and setup information contact Racing Dept. by fax at (715) 847-6869, phone (715) 848-4971.

SPEED RUNS

Generally, a speed run sled will be set up very similar to an ice drag sled with the following differences.

- Some organizations do not allow lowering for stock class sleds. Check your rules. Shorter springs may be an option to try.
- Because holeshots are not important, engagement speed does not have to be set at 5000 RPM. Top speed at the end of the course is the only concern.
- Chaincase gearing can be set for high theoretical top speeds. Use the largest top and smallest bottom sprocket available. This will keep the belt low in the drive pulley which lowers the belt and countershaft speed which makes the transmission more efficient.
- As few studs as possible should be used. It takes energy to push a stud into the ice and pull it back out again. Since holeshots are not important, use only enough studs to maintain control at top speed.
- Use standard trail carbide runners with the sharp edge worn down a bit. This way you will have steering control without sacrificing speed.
- Run with a very short limiter strap and soft center spring. This will reduce the track approach angle which helps top speed.

OVAL RACING

Special Rules

- Rear of tunnel must be enclosed per specifications in the I.S.R. rulebook.
- Snowflap must be retained by chains or 3 mm (1/8 in) diameter cable.
- Tail light AND brake light element must be on at all times! Add a jumper wire inside the taillight assembly.
- Any glass lenses must be taped over with clear tape.

Front Suspension

- Relocate ski mount in spindle by drilling out the predrilled hole 10 mm (.39 in) behind stock mounting hole.
- Lower the ride height to the two inch minimum travel requirement. Shorter springs are available.
- Valve shocks to light compression and medium rebound
- Camber: Left = 0 degrees
Right = Negative 2 to 4 degrees
- Verify ski toe out, about 3 mm (1/8 in) at the carbide edge.
- Steering ball joints should have as many jam nuts added as will fit between the tie rod and the ball joint. This helps prevent bending of the threaded portion of the ball joint.

Center

- Use spring with soft preload and compression and medium rebound.

Rear Suspension

- Lower the ride height to the 51 mm (2 in) minimum travel requirement.
- Install a 4th idler wheel on the rear axle.
- Stiffer springs and firm preload may be required to reduce weight transfer and help keep the skis on the ice. If the handling is generally good but the inside ski is lifting, increase the right rear spring preload.
- Remove non guide clips and install taller track guides on the right side of the track or use designated oval track.

SECTION 08 - COMPETITION PREPARATION

Traction

- Most rules limit maximum stud height to 3/8" over the tallest part of the track. Track cutting is illegal. A camoplast oval track is available (P/N 700 9844), it has 19 mm (3/4 in) lug height and tall guide clips for oval racing.
- Use a thin profile, sharp tipped stud for hard ice conditions. If the track conditions get sloppy, exchange some picks for a chisel or wedge type stud.
- Seven picks per bar for a total of 336 studs will be required for all sleds up to about 100 HP. Bigger sleds may require more picks and/or hooker plates.
- Use 51 mm (2 in), 2 hole angled aluminum backer plates for the majority of your pattern, especially on the outside belts. The right hand belt will need a 51 mm (2 in) plate on every pitch. Fill in the pattern with 25 mm (1 in) square backer plates. The pattern should not repeat itself for at least 5 pitches.
- Use a good quality square bar carbide runner with 254 mm (10 in) of carbide for starters. As you gain experience, try 356 mm (14 in) of carbide for more front end bite.
- Studs and carbides need to be SHARP! The carbide must shave your fingernail when scraped across and studs must prick your finger.

Controls

- You will probably be more comfortable in the corners if you make a curved extension for the left side of the handlebars. Many drivers make a new set of bars from the same size tubing and custom bend it to fit their preference. (Check your rule book for requirements on handlebars).
- You may also want to fabricate a stirrup for your right foot.

Transmission

- You need aggressive shifting to get a good hole-shot but you also need good backshifting. Here again, testing is the key to success.
- Use the lowest TRA setting that still allows you to maintain correct RPM when exiting the corners.
- Gear for the speed you will go on the course.
- Break in several belts of the same type and size and set up your pulleys to work with these belts.
- Maintain your clutches on a weekly basis. A clean, free moving driven pulley is important to good backshifting. Clean the pulley faces with acetone on a regular basis.

Physical Conditioning

- While a well set up sled will be easier to drive than a poor one, it still takes good arm strength to turn a stocker with aggressive carbide. Train your upper body for strength and endurance. A good overall conditioning program that also works your legs and respiratory system is a smart idea. While it may not seem like 3 lap heats are very long, 10 lap finals on a short track with tight corners can really wear you down.

RACE CIRCUITS

Remember it is the driver and team's responsibility to have the sled race-ready in accordance with the rules of the circuit you race in. All races approved for Ski-Doo's Winners Circle contingency awards are governed by the general rules laid out in the ISR annual handbook. It is common practice for the various race associations across North America to modify the ISR rules for local use. This does result in conflicting standards and therefore every driver must carefully check the rules.

Contact the following circuits for detailed race rules.

SECTION 08 - COMPETITION PREPARATION

| | | |
|-------------|---|-------------------------------------|
| ISR | International Snowmobile Racing | 262-335-2401 PH 262-335-9440 Fax |
| WSA | World Snowmobile Association | 651-209-7400 PH 651-209-7447 Fax |
| CSRA | Canadian Snowcross Racing Association | 905-476-7182 PH 905-476-7157 Fax |
| ASRA | American Snowcross Racing Association | 905-476-7182 PH 905-476-7157 Fax |
| RMR | Rock Maple Racing | 802-368-2747 PH |
| USSA | U.S. Snowmobile Association | 262-252-2000 PH |
| WSA Pro Ice | World Snowmobile Association Pro Ice | 763-428-3800 PH 763-428-3897 Fax |
| SCM | Super Competition Motorsport | 450-794-2298 PH 450-794-2450 Fax |
| PRO | Power Sled Racing Organization | 315-827-4849 PH |
| NSRA | National Snowmobile Racing Assn. | 815-789-4266 PH |
| MSDRA | Michigan Snowmobile Drag Racing Association | 810-989-9554 PH |
| RMXCRC | Rocky Mountain Cross Country Racing Circuit | 208-887-4884 PH |
| BEST | Big East Snocross Tour | 315-768-3343 |
| MIRA | Midwest International Racing Association | 989-257-5264 |
| RMSHA | Rocky Mountain Snowmobile Hillclimb | 406-748-3111 |
| NIDRA | Northern Illinois Drag Racing Assn. | 517-522-8584 |
| NWSA | Northwest Sno-cross Assn. | 425-774-0505 |

PARTS SUPPORT

The **Ski-Doo** factory support trucks will be on hand at most major Snowcross, grass drag and oval events across the U.S. and Canada. The purpose of these trucks is to provide parts, and technical support for all racers racing Ski-Doo snowmobiles.

The Ski-Doo race support trucks carry an extensive inventory of parts, however it is always best to be self contained and not to count on anyone but himself for parts support.

SUGGESTED SPARE PARTS

You should have a self-contained parts supply. The factory parts truck won't always be there to back you up.

- parts book
- piston assembly and circlips
- tuned pipe
- radiator cap
- gas cap
- drive belts
- carb. inlet needle and seat
- drive and driven clutch springs
- driven clutch rollers
- TRA adjuster screws and nuts
- drive clutch retainer bolt
- brake fluid
- steering tie rods and ball joints
- ski shock assembly
- skis and carbide runners
- ski bolt and nut
- light bulbs
- windshield and O-rings
- tether cord and switch
- handlebars and grips
- shop manual/specification booklet
- engine gaskets, seals and O-rings
- rewind assembly and components
- exhaust springs
- spark plugs
- spark plug caps and wires
- main jets
- chaincase chain and sprockets
- TRA clutch puller and forks
- TRA clutch rollers
- driven pulley circlip and keys
- brake lever
- front suspension replacement parts
- brake pads
- steering arms
- throttle lever and housing

SECTION 08 - COMPETITION PREPARATION

- tail light assembly
- hood latch rubber
- synthetic chaincase oil.

Things to DOO Between Heats:

- carefully remove ice and snow build up front and rear suspension
- inspect suspension components
- check/replace studs
- check tightness of all suspension bolts
- check all idler wheels for missing rubber and condition of bearings
- lube steering and front suspension ball joints
- check chain tension and oil level
- check clutch alignment and clean pulley faces
- coolant hose condition/routing
- check electrical connections
- inspect track for damage and missing guide clips
- check skis and carbides
- check ski toe out
- check brake disc and pad condition
- grease all zerk fittings
- check track tension and alignment
- check brake fluid and operation
- inspect drive belt
- check throttle and oil cable and
- check light bulbs.

Replace any tools or parts used from race vehicle supply.

Shut off fuel before leaving for the night.

SECTION 08 - COMPETITION PREPARATION

EQUIVALENT WEIGHTS AND MEASURES CHART

| LINEAR MEASURE | |
|--|----------------------------------|
| 1 inch = 25.4 millimeters (mm) | 1 millimeter = .03937 inch |
| 1 inch = 2.54 centimeters (cm) | 1 centimeter = .3937 inch |
| 1 foot = .3048 meter (m) | 1 meter = 3.2808 feet |
| 1 yard = .914 meter (m) | 1 meter = 1.093 yards |
| 1 statute mile = 1.609 kilometers (km) | 1 kilometer = .6214 statute mile |

| WEIGHT | |
|-------------------------------|----------------------------|
| 1 Ounce = 28.35 Grams (g) | 1 Gram = .03527 Ounce |
| 1 Pound = .4536 Kilogram (kg) | 1 Kilogram = 2.2046 Pounds |
| 1 Ton = .907 Metric Ton (t) | 1 Metric Ton = 1.102 Tons |

| VOLUME | |
|--|--|
| 1 Fl. U.S. Ounce = 29.574 Milliliters = .2957 Deciliter = .0296 Liter | |
| 1 Fl. U.S. Pint = 473.18 Milliliters = 4.7316 Deciliters = .4732 Liter | |
| 1 Fl.U.S. Quart = 946.35 Milliliters = 9.4633 Deciliters = .9463 Liter | |
| 1 U.S. Gallon = 3.785 Liters | |
| 1 Cu. Inch = 16.387 Cu. cm | |
| 1 Cu. Centimeter = .061 Cu. Inch | |
| 1 Cu. Foot = 2.831.16 Cu. Cm. | |
| 1 Cu. Decimeter = .0353 Cu. Foot | |
| 1 Cu. Yard = .7646 Cu. Meter | |
| 1 Dry Quart = 1.101 Liters | |

| TEMPERATURE | |
|--------------------------------|---|
| 32° Fahrenheit = 0° Celsius | $^{\circ}\text{F} = 9/5^{\circ}\text{C} + 32$ |
| 0° Fahrenheit = -17.8° Celsius | $^{\circ}\text{C} = (^{\circ}\text{F} - 32) \times 5/9$ |

| SPEED | |
|-------------------|--|
| 1 MPH = 1.61 km/h | |

SECTION 08 - COMPETITION PREPARATION

FUEL/OIL RATIO CHARTS

50/1

METRIC (SI)

500 mL of oil + 25 L of fuel = 50/1

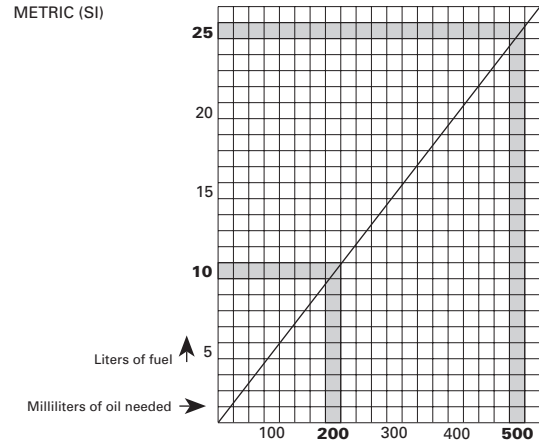

IMPERIAL

16 oz of oil + 5 Imp. gal of fuel = 50/1

500 mL of oil + 5.5 Imp. gal of fuel = 50/1

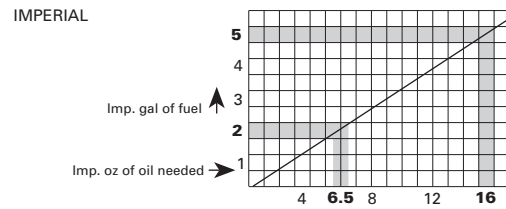

UNITED STATES

13 oz of oil + 5 U.S. gal of fuel = 50/1

500 mL of oil + 6.6 U.S. gal of fuel = 50/1

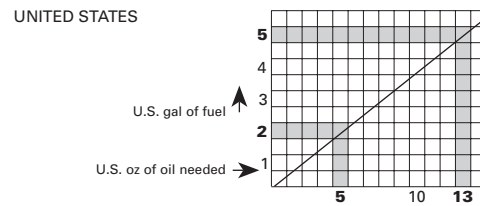

A00A1WJ

SECTION 08 - COMPETITION PREPARATION

40/1

METRIC (SI)

500 mL of oil + 20 L of fuel = 40/1

METRIC (SI)

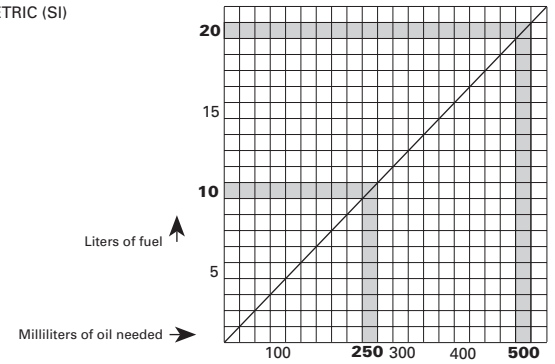

IMPERIAL

16 oz of oil + 4.0 Imp. gal of fuel = 40/1

500 mL of oil + 4.8 Imp. gal of fuel = 40/1

IMPERIAL

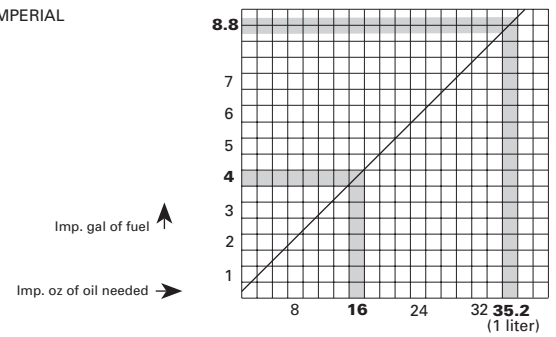

UNITED STATES

500 mL of oil + 5.3 U.S. gal of fuel = 40/1

UNITED STATES

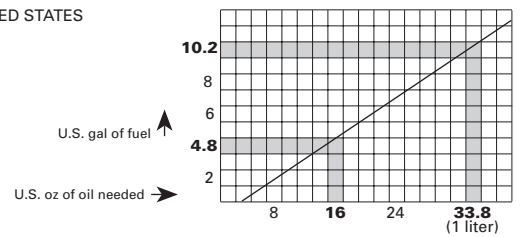

A00A2WJ

SECTION 08 - COMPETITION PREPARATION

33/1

METRIC (SI)

500 mL of oil + 16.5 L of fuel = 33/1

METRIC (SI)

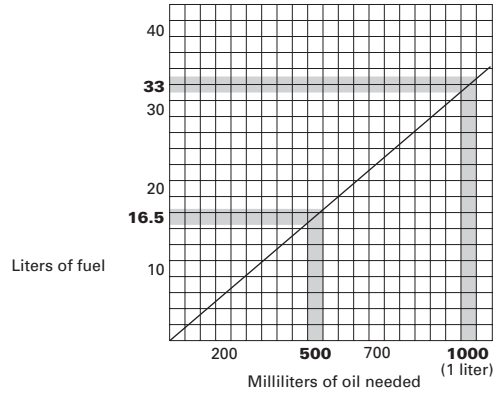

IMPERIAL

24 oz of oil + 5 Imp. gal of fuel = 33/1

500 mL of oil + 3.6 Imp. gal of fuel = 33/1

IMPERIAL

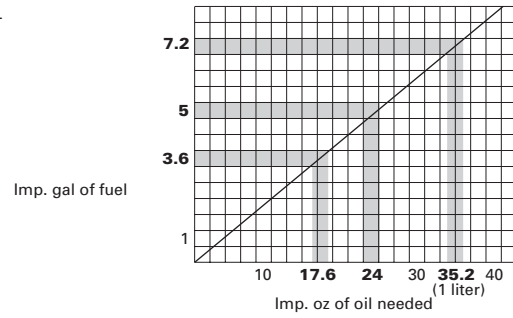

UNITED STATES

19.4 oz of oil + 5 U.S. gal of fuel = 33/1

500 mL of oil + 4.4 U.S. gal of fuel = 33/1

UNITED STATES

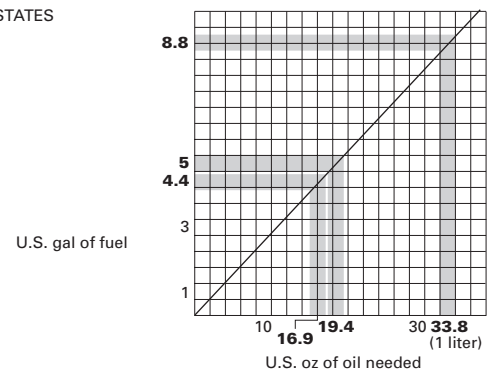

A00A6KJ

SECTION 08 - COMPETITION PREPARATION

25/1

METRIC (SI)

500 mL of oil + 12.5 L of fuel = 25/1

METRIC (SI)

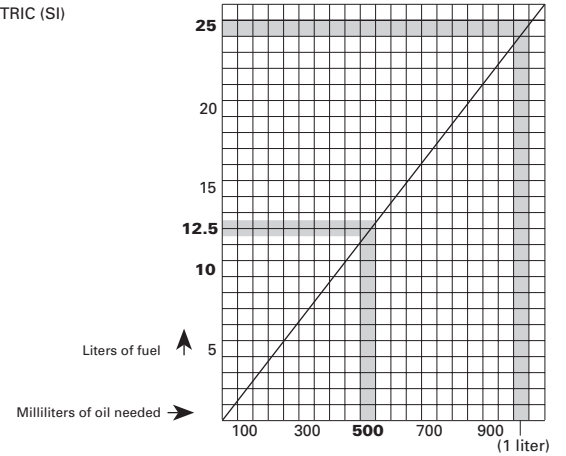

IMPERIAL

16 oz of oil + 2.5 Imp. gal of fuel = 25/1

500 mL of oil + 2.7 Imp. gal of fuel = 25/1

IMPERIAL

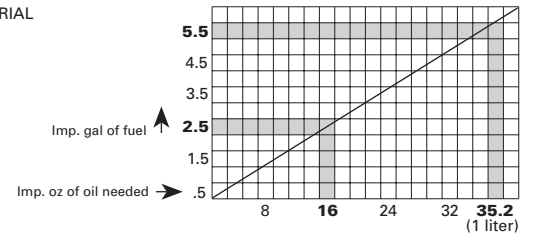

UNITED STATES

15 oz of oil + 2.8 U.S. gal of fuel = 25/1

500 mL of oil + 3.2 U.S. gal of fuel = 25/1

UNITED STATES

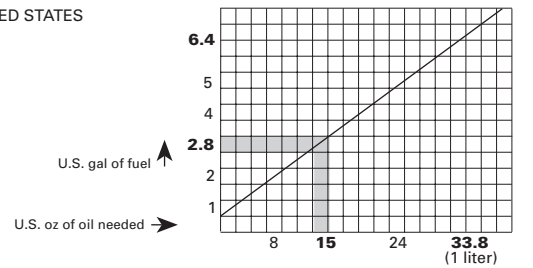

A00A2YJ

SECTION 08 - COMPETITION PREPARATION

20/1

METRIC (SI)

500 mL of oil + 10 L of fuel = 20/1

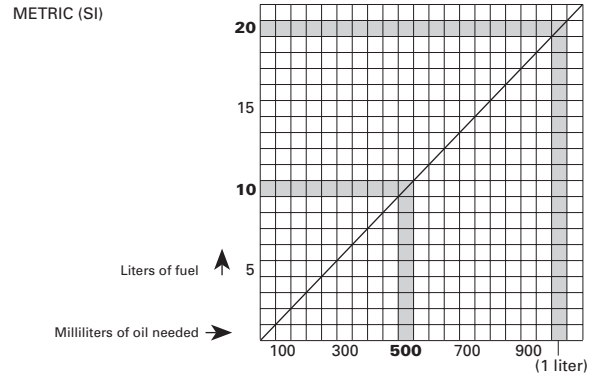

IMPERIAL

16 oz of oil + 2 Imp. gal of fuel = 20/1

500 mL of oil + 2.2 Imp. gal of fuel = 20/1

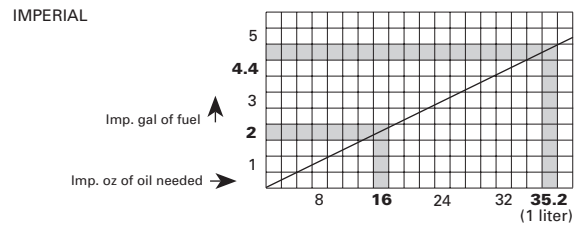

UNITED STATES

16 oz of oil + 2.4 U.S. gal of fuel = 20/1

500 mL of oil + 3.2 U.S. gal of fuel = 20/1

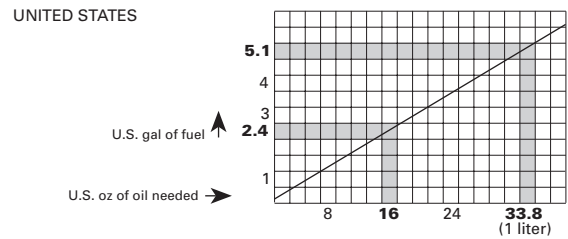

A00A2ZJ

STOCK CLASS PREPARATION

NOTE: Any machining and/or grinding is illegal in stock class racing. Keep your machine legal!

1. Remove and disassemble the engine according to correct *Shop Manual* procedures.
2. With the crankshaft resting in the lower half of the crankcase, set up a dial indicator and check the run out of the crankshaft at both ends. You should see no more than 0.05 mm (0.002 in) run out. If you have the capability, adjust the crankshaft as close to perfect as possible.

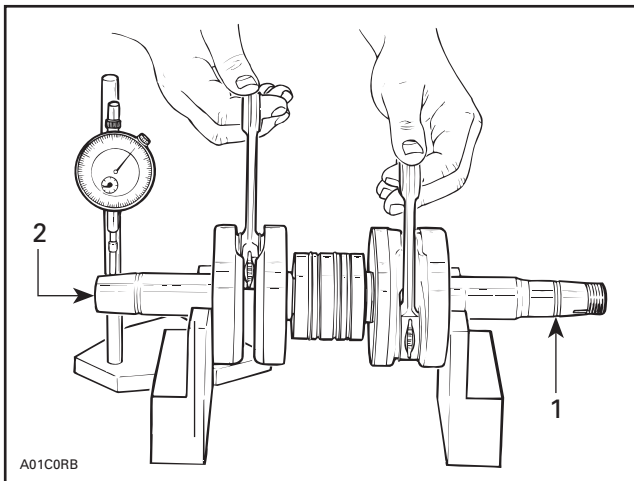

1. Measure behind the key
2. Measure at 6 mm (1/4 in) from edge

3. Set your cylinder base gaskets and cylinders on the upper half of the crankcase, and lightly torque the cylinders to the half. Be sure to install exhaust manifold on the cylinders before tightening them to the upper crankcase half to ensure the same position of the cylinders on final assembly.

Check the match of the gaskets and cylinders to the base; match them perfectly with a die grinder in the areas of transfer port passages. Also check for any over lap of the exhaust manifold gaskets where the exhaust manifold joins the cylinders. Before reassembling make sure that parts are free of any dust or particles.

4. Check piston to cylinder clearances, ring end gap, cylinder taper and out-of round.
5. Assemble the engine using the correct sealants where needed.

Rotary valve timing should be set with the closing edge as close to specs as possible or slightly higher.

NOTE: Refer to chart page.

6. The engine should be pressure-tested for air leaks. It should hold 6 PSI for 6 minutes with no more than a 1 PSI/min. loss.
7. Lube the rewind and inspect the rope for frays or cuts.
8. Oval racing must use taillight, brake light element on continuously (jumper from taillight wire terminal to brake light terminal on taillight assembly), regulator, tachometer, and temperature gauge.
9. Synchronize carburetors so that they open precisely together and ensure that the cut aways of the slides clear the inlet bores of the carburetors. After carb. adjustment, adjust oil injection pump.
10. On RAVE valve-equipped engines, check for free movement of the RAVE valve mechanism. Check the passageways between valve piston and exhaust port for any carbon buildup.

Adjust RAVE preload. It is better to have the valve open a little earlier than later.

NOTE: Pump fuels can be oxygenated or contain alcohol. Have your fuel tested prior to the race.

Do not use fuel de-icers.

11. Tie wrap ignition wire connectors together.
12. Adjust carburetors for atmospheric conditions. (See ENGINE PREPARATION section).
13. Break in a new engine before racing it. Performance can be gained by getting some run time on the engine. Ten hours of break-in is recommended.

SECTION 08 - COMPETITION PREPARATION

TECHNICAL DATA

Supplement for model: REV 600 2004

| MODEL: REV 600 2004 | | | | | |
|--|--|--------------------------------------|-----------------------------|---------------------|------------|
| RACING TYPE | | -GRASS DRAGS- | | | |
| | Maximum horsepower * ① RPM | 7600-7700 | | | |
| C A R B U R E T O R | Carburetor type | | <i>PTO</i> | <i>CENTER</i> | <i>MAG</i> |
| | Main jet | foam/paper type filters | 400 | | 400 |
| | Needle | | <i>std</i> | | <i>std</i> |
| | Needle clip position (use a plastic washer to raise the needle) P/N 404 137 600 | | | | |
| | Slide cut-away | | <i>std</i> | | <i>std</i> |
| | Pilot jet | P/N 404 110 300 | 25 | | 25 |
| | Needle jet | | | | |
| | Pilot screw adjustment | ± 1/8 turn | 2.0 | | 2.0 |
| | Needle valve | | <i>std</i> | | <i>std</i> |
| | Fuel | | <i>minimum 100 octane</i> | | |
| | D R I V E R A T I O | Drive ratio | 20 teeth P/N 504 074 800 | | |
| Chain | | 43 teeth P/N 504 148 600 | 72 links P/N 504 151 883 | | |
| Drive pulley | | Type of drive pulley | TRA III | | |
| | | Ramp identification | 419 P/N 417 222 557 | | |
| | | Calibration screw position | <i>no. 3</i> | | |
| | | Spring white/silver 260 lb-420 lb | P/N 417 222 164 | | |
| | | Clutch engagement | RPM | 5200 | |
| | | Pin weight | 417 222 594 | 18.8 grams | |
| | | Lever | | <i>std</i> | |
| Driven pulley | | Spring | Color std White | P/N 486 130 046 | |
| | | | Preload kg (lb) | <i>B 3 position</i> | |
| | | Cam whitout RER | Angle 48°-44° std | | |
| Drive belt | | P/N 417 300 230 | | | |
| Calibration done at temperature of 20° Celcius | | | | | |
| ① The maximum horsepower RPM is applicable on the vehicle. It may be different under certain circumstances and BOMBARDIER INC. reserves the right to modify it without obligation. | | | | | |

- A) Ski Spring = 150 lb/in P/N 415 020 700 - 5 mm preload shock length = 360 mm
- B) Center Spring = std 2-1/4 in travel max. for center arm
- C) Rear Spring = 11.9 mm 140° 3rd position: 486 099 100 right
 486 099 300 left
- D) 3-1/2 in travel max. for rear arm
- E) Block ACM full uncouple (thickness block downside)

SECTION 08 - COMPETITION PREPARATION

Supplement for model: REV 800 2004

| MODEL: REV 800 2003 | | | | | |
|--|------------------------|--------------------------------------|---------------------------|------------------------|--------------------------|
| RACING TYPE | | -GRASS DRAGS- | | | |
| Maximum horsepower * | | ① RPM | 7600 | | |
| C A R B U R E T O R | Carburetor type | | | | |
| | | | <i>PTO</i> | <i>CENTER</i> | <i>MAG</i> |
| | Main jet | foam/paper type filters | | 370 | 370 |
| | Needle | P/N 404 162 033 | | 9 DG158 | 9 DG158 |
| | Needle clip position | | 3° | | 3° |
| | Slide cut-away | | <i>std</i> | | <i>std</i> |
| | Pilot jet | | 30 | | 30 |
| | Needle jet | | — | | — |
| | Pilot screw adjustment | ± 1/8 turn | | 1.0 | 1.0 |
| | Needle valve | | <i>std</i> | | <i>std</i> |
| | Fuel | | <i>minimum 100 octane</i> | | |
| D R I V E R A T I O | Drive ratio | | 21 teeth P/N 504 084 000 | | |
| | Chain | | 23= P/N 504 085 400 | 43= <i>std</i> | 74 links P/N 504 151 859 |
| | Drive pulley | Type of drive pulley | | <i>TRA III</i> | |
| | | Ramp identification | | 419 P/N 417 222 557 | |
| | | Calibration screw position | | <i>no. 4</i> | |
| | | Spring white/silver 260 lb-420 lb | | P/N 417 222 164 | |
| | | Clutch engagement | | RPM | 5000 |
| | | Pin weight (kit pin P/N 486 400 003) | | 20.5 grams | |
| | | Lever | | <i>std</i> | |
| | Driven pulley | Spring | Color | blue | P/N 417 126 848 |
| | | | Preload | kg (lb) | 4° position |
| | | Cam | Angle | 50°-47° | P/N 417 126 580 |
| Drive belt | | P/N 486 300 230 | | | |
| Calibration done at temperature of 20° Celcius | | | | | |
| ① The maximum horsepower RPM is applicable on the vehicle. It may be different under certain circumstances and BOMBARDIER INC. reserves the right to modify it without obligation. | | | | | |

- A) Ski Spring = 150 lb/in P/N 415 020 700 - 5 mm preload shock length = 360 mm
- B) Center Spring = *std* 2-1/4 in travel max. for center arm
- C) Rear Spring = 11.9 mm 140° 3rd position: 486 099 100 right
 486 099 300 left
- D) 3-1/2 in travel max. for rear arm
- E) Block ACM full uncouple (thickness block downside)

SECTION 08 - COMPETITION PREPARATION

Supplement for model: REV 440 stock 2003

| MODEL: REV 440 stock 2003 | | | | | | |
|--|-----------------------------|-------------------------------------|---------------------------|--------------------------|---------------------|--|
| RACING TYPE | | -GRASS DRAGS- | | | | |
| | Maximum horsepower * | ① RPM | 8200 | | | |
| C A R B U R E T O R | Carburetor type | | TMX 34 mm | | | |
| | | | <i>PTO</i> | <i>CENTER</i> | <i>MAG</i> | |
| | Main jet | kick ass filters | 230 | | 230 | |
| | Needle | | <i>std</i> | | <i>std</i> | |
| | Needle clip position | | 4° | | 4° | |
| | Slide cut-away | | <i>std</i> | | <i>std</i> | |
| | Pilot jet | | 30 | | 30 | |
| | Needle jet | | <i>std</i> | | <i>std</i> | |
| | Pilot screw adjustment | ± 1/8 turn | 1.0 | | 1.0 | |
| | Needle valve | | <i>std</i> | | <i>std</i> | |
| | Fuel | | <i>minimum 108 octane</i> | | | |
| D R I V E R A T I O | Drive ratio | 4 P/N 504 148 600 | 43= std | 19 teeth P/N 414 680 500 | | |
| | Chain | 72 links <i>std</i> P/N 504 151 883 | | | | |
| | Drive pulley | Type of drive pulley | | TRA III | | |
| | | Ramp identification | | 296 <i>std</i> | | |
| | | Calibration screw position | | <i>no. 4</i> | | |
| | | Spring green 280 lb-420 lb | | P/N 415 020 100 | | |
| | Pin Threated 417 222 477 | Clutch engagement | | RPM | 5300 | |
| | | (3 set screw P/N 206 260 699) | | 13 grams | | |
| | | Lever | | <i>std</i> | | |
| | Driven pulley | Spring | Color | beige | | |
| | | | Preload | kg (lb) | <i>A-5 position</i> | |
| | | Cam without RER | Angle | 56°-44° | P/N 860 427 400 | |
| | Drive belt | P/N 414 860 700 | | | | |
| Calibration done at temperature of 25° Celcius | | | | | | |
| ① The maximum horsepower RPM is applicable on the vehicle. It may be different under certain circumstances and BOMBARDIER INC. reserves the right to modify it without obligation. | | | | | | |

TABLE OF CONTENTS

ENGINE 09-2
TRANSMISSION 09-6
SUSPENSION 09-10
VEHICLE 09-13
NEW TOOLS AND USAGE 09-14

SERVICE TOOLS

ENGINE

Hose pincher (2)
(P/N 295 000 076)

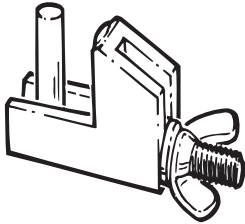

A01B2I4

APPLICATION

All vehicles.

NOTE: Only the P/N has been changed. This hose pincher is identical to the P/N 529 009 900.

Engine leak tester kit
(P/N 861 749 100)

1) Hand pump
(P/N 529 021 800)

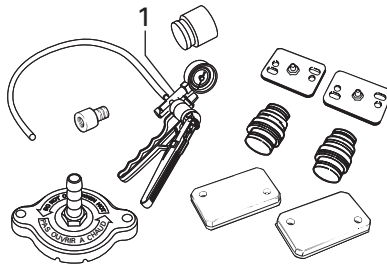

A01B5F5

APPLICATION

All engines.

1) Piston pin puller
(P/N 529 035 503)

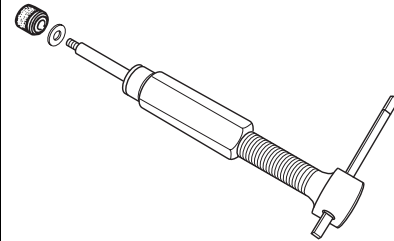

A02B094

- 2) Sleeve kit 18 mm
(P/N 529 035 541)
- 3) Sleeve kit 20 mm
(P/N 529 035 542)

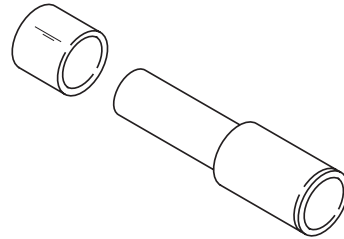

A01B5A4

NOTE: 18 mm sleeve kit contains 1 shouldered sleeve and 3 sleeves. 20 mm sleeve kit contains 1 shouldered sleeve and 2 sleeves.

APPLICATION

- 1) All engines.
- 2) 277, 443, 503 and 809 engine.
- 3) 593, 670 and 693 engines.

NOTE: The previous piston pin puller (P/N 529 029 000) can be upgraded by adding protector (P/N 529 035 513) and replacing the expansion sleeve with appropriate sleeve kit.

Magneto puller ring
(P/N 420 876 080)

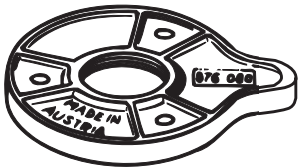

A00C1R4

APPLICATION

All engines except 247.

Piston circlip installer
(P/N 529 035 686) 20 mm



A32B0C4

APPLICATION

Engines with tab type circlip.

Magneto puller
(P/N 529 035 547)

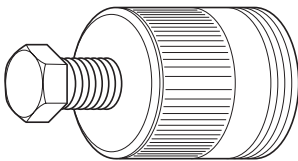

A00C1A4

APPLICATION

All engines except 247.

NOTE: The previous extractor (P/N 529 022 500) can be upgraded by replacing the screw with the new one (P/N 529 035 549).

ENGINE (continued)

Rubber pad
(P/N 529 023 400)

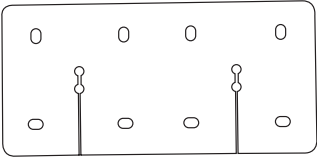

A01B4C4

APPLICATION
All cageless bearing engines.

Multimeter
(P/N 529 035 788)

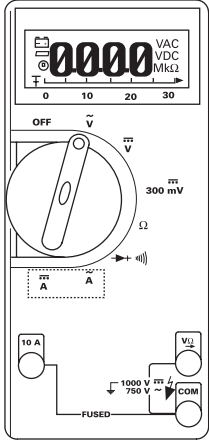

F01B104

APPLICATION
All models.

The following tools are highly recommended to optimize your basic tool kit and reduce repair time.

1-2) Crankshaft bearing puller with screw
(P/N 420 877 635)

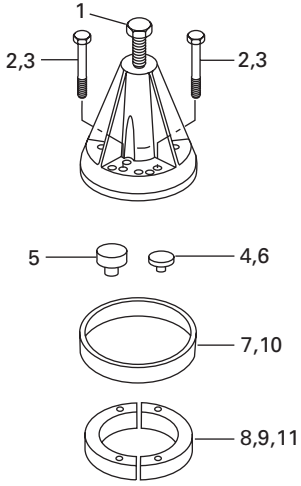

A01B547

APPLICATION
All engines.

| | |
|--|-------------------|
| 1) Screw M16 x 1.5 x 150 | (P/N 420 940 755) |
| 2) Screw M8 x 40 (4) | (P/N 420 840 681) |
| 3) Screw M8 x 70 (4) | (P/N 420 841 201) |
| 4) Crankshaft protector 247 engine. | (P/N 420 976 890) |
| 5) Crankshaft protector PTO All engines except 247. | (P/N 420 876 552) |
| 6) Crankshaft protector MAG All engines except 247. | (P/N 420 876 557) |
| 7) Puller ring Use with half rings (P/N 420 977 475 or 420 276 025). | (P/N 420 977 490) |
| 8) Half ring (2) For 72 mm O.D. bearings. | (P/N 420 977 475) |
| 9) Half ring (2) For 62 mm O.D. bearings. | (P/N 420 276 025) |
| 10) Puller ring For half rings (P/N 420 977 479). | (P/N 420 977 494) |
| 11) Half ring (2) For 80 mm O.D. bearings. | (P/N 420 977 479) |

SECTION 09 - SERVICE TOOLS

ENGINE (continued)

Piston circlip installer

- A) (P/N 529 035 561) 18 mm
- B) (P/N 529 035 562) 20 mm



A00B4Y4

APPLICATION

A) All engines except 593, 670, 693 and 793.

NOTE: This tool replaces circlip installer (P/N 529 016 900).

B) 2001 and older 593, 670 and 693 engines.

NOTE: This tool replaces circlip installer (P/N 290 877 016).

Piston pin/connecting rod bearing centering tool
(P/N 529 009 100)

NOTE: New diameter is 9.65 mm (0.380 in).

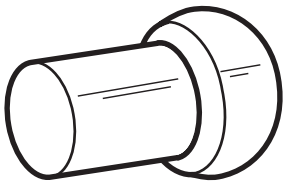

A01B1R4

APPLICATION

All engines except cageless and 670 engines.

Ring compressor

- A) (P/N 420 876 090) (62 mm)
- B) (P/N 420 876 974) (69.5 mm)
- C) (P/N 420 876 970) (72 mm)
- D) (P/N 420 876 972) (76 mm)
- E) (P/N 420 876 975) (67.5 mm)
- F) (P/N 529 030 800) (78 mm)

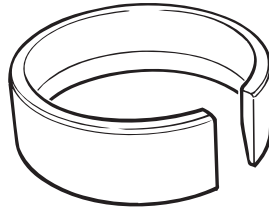

A01B1T4

APPLICATION

- A) 377 engine.
- B) 467 and 494 engines.
- C) 503, 253 and 536 engines.
- D) 582, 583 and 643 engines.
- E) 443 and 447 engines.
- F) 670 engine.

Cylinder aligning tool

- A) (P/N 420 876 904) (on exhaust side)
- B) (P/N 420 876 171) (on intake side)

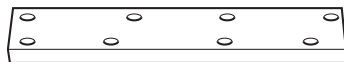

A00B084

APPLICATION

- A) 2-cylinder liquid cooled engines.
- B) 2-cylinder fan cooled engines.

Driver tool

(P/N 529 035 521)



A00B4O4

APPLICATION

Mini Z.

Attachment

(P/N 529 035 522)

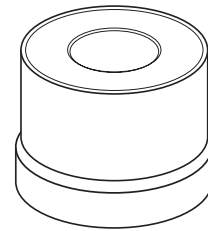

A00B4P4

APPLICATION

Mini Z.

Pilot 22 mm

(P/N 529 035 523)

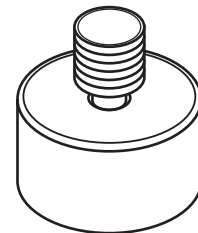

A00B4Q4

APPLICATION

Mini Z.

ENGINE (continued)

Carburetor tool kit
(P/N 404 112 000)

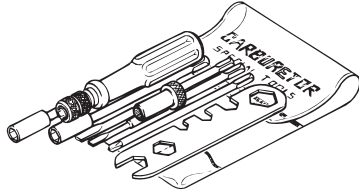

A00B2F4

APPLICATION
All models.

Stroboscopic timing light
(P/N 529 031 900)



A00B4F4

APPLICATION
All engines.

Injection pump gear holder
(P/N 420 277 905)

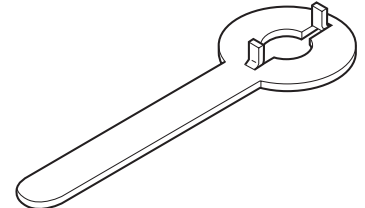

A00C164

APPLICATION
All liquid cooled engines.

Float level gauge
(P/N 529 035 520)

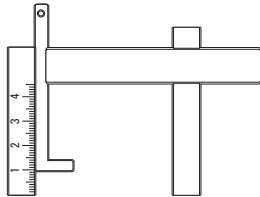

A00B4N4

APPLICATION
All models.

RAVE movement indicator
(P/N 861 725 800)

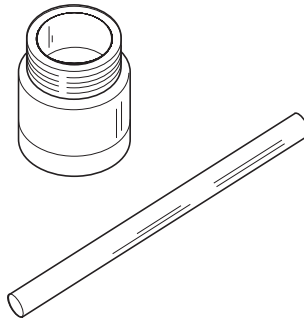

A18B014

APPLICATION
All RAVE equipped engines.

Digital/induction type tachometer
(P/N 529 014 500)

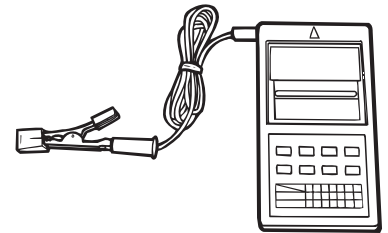

F01B1G4

APPLICATION
All engines.

Circuit tester
(continuity light)
(P/N 414 012 200)

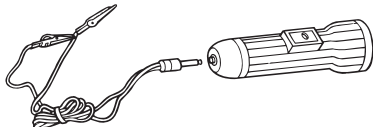

A00C214

APPLICATION
All vehicles.

Dial indicator
(TDC gauge)
(P/N 414 104 700)

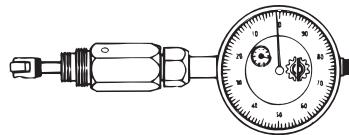

A00B4E4

APPLICATION
All engines.

Exhaust spring installer/remover
(P/N 529 035 559)

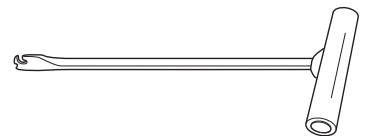

A00C3S4

APPLICATION
All models.

SECTION 09 - SERVICE TOOLS

ENGINE (continued)

Large hose pincher
(P/N 529 032 500)

(TYPICAL)

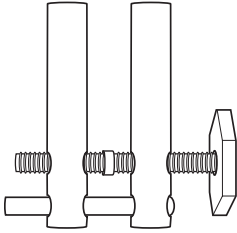

F01B234

APPLICATION

All vehicles.



Spark plug lift ring
(P/N 529 035 876)



A33B064

APPLICATION

REV.

TRANSMISSION

Driven pulley opening tool
(P/N 529 017 200)

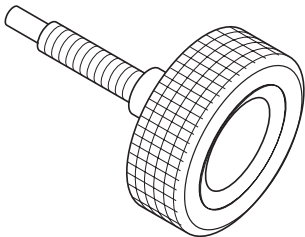

A00A1A4

APPLICATION

All non-RER models.

TRA drive pulley puller
(P/N 529 022 400)

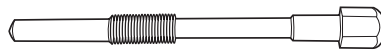

A06B014

APPLICATION

TRA drive pulley for the 454, 494, 599, 670, 699, 779 and 809 engines.

TRA drive pulley puller
(P/N 529 007 900) (25 mm)

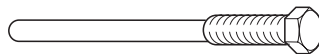

A18B044

APPLICATION

TRA drive pulley for 443, 467, 503, 536 and 537 engines.

Forks (3)
(P/N 529 005 500)

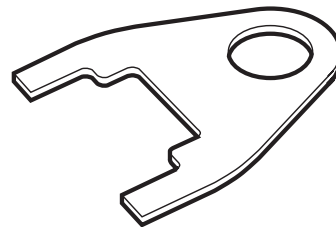

A16B014

APPLICATION

All vehicles equipped with a TRA drive pulley.

Clutch holder
(P/N 529 006 400)



A01B154

APPLICATION

All TRA drive pulleys.

Transmission alignment bar



A01B4D4

APPLICATION

F-Series, S-Series and ZX series with TRA.

TRANSMISSION (continued)

Drive belt tension adjuster tool
(P/N 529 008 700)

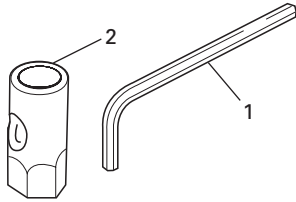

A15B044

Parts included:

- 1) Hexagonal wrench
(P/N 420 876 730).
- 2) Socket wrench
(P/N 529 015 000).

APPLICATION

All vehicles except Élan, Tundra II and Skandic WT.

Driven pulley spring compressor
(P/N 529 035 300)

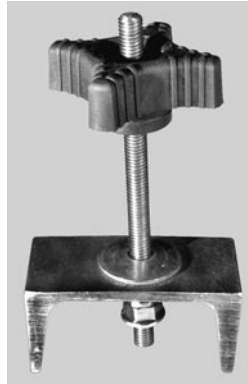

A05B034

APPLICATION

Tundra R.

Countershaft bearing
remover/installer
(P/N 529 035 699)

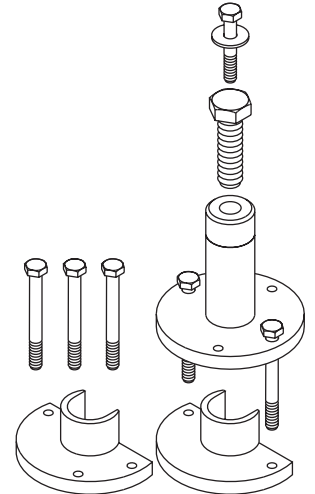

A00B5K4

APPLICATION

ZX and CK3 Series.

NOTE: This tool replaces CK3 series countershaft bearing remover/installer (P/N 529 035 554).

Pulley spring compressor
(P/N 529 035 524)

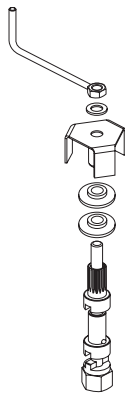

A02D1P4

APPLICATION

All models.

NOTE: This tool has Acme threads and replaces spring compressor (P/N 529 018 600).

Tension tester
(P/N 414 348 200)



A00C074

APPLICATION

All models.

SECTION 09 - SERVICE TOOLS

TRANSMISSION (continued)

The following tools are highly recommended to optimize your basic tool kit and reduce repair time.

Driven pulley opening tool
(P/N 529 035 501)



A03D2P4

APPLICATION

S and CK3 series with RER.

NOTE: This tool replaces driven pulley opening tool (P/N 529 019 500).

Large bushing extractor
(P/N 529 035 576)



A02D1Q4

APPLICATION

Formula type driven pulley.

NOTE: Use this tool only with new puller (P/N 529 035 524) that has Acme threads and support plate included with extractor (P/N 529 031 100).

Chaincase seal pusher
(P/N 529 035 584)

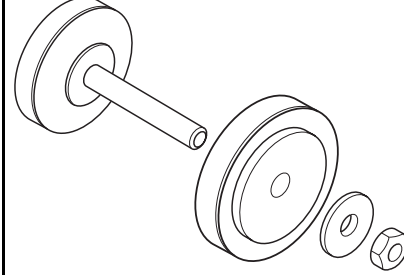

A00B504

APPLICATION

S, F, CK3 and ZX series.

NOTE: This tool replaces chaincase upper seal pusher (P/N 529 032 300).

Bushing extractor/installer
(P/N 529 031 300)



A01B5G4

APPLICATION

TRA drive pulley spring cover with replaceable bushing

Large bushing extractor
(P/N 529 035 575)

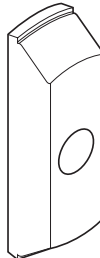

A02D1Q4

APPLICATION

LPV 27 driven pulley.

NOTE: Use this tool only with new puller (P/N 529 035 524) that has Acme threads and support plate included with extractor (P/N 529 031 100).

TRA drive pulley puller (27 mm)
(P/N 529 010 100)

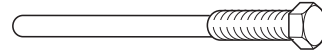

A18B044

APPLICATION

TRA drive pulley (27 mm) shaft except 454, 670 and 779 engines.

TRANSMISSION (continued)

Drive axle sprocket adjuster
(P/N 861 725 700)

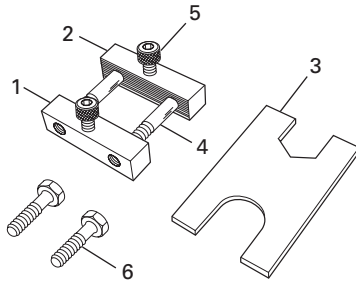

A01B204

Parts included in the kit:

- 1) Block with threads
(P/N 529 010 700)
- 2) Block without threads
(P/N 529 010 800)
- 3) Plate
(P/N 529 010 600)
- 4) Bolt M10 (2)
(P/N 222 007 565)
- 5) Allen screw M8 (2)
(P/N 222 983 065)
- 6) Screw M8 (2)
(P/N 222 082 565)

NOTE: When the tool is to be used between tunnel and sprocket use screws M8.

APPLICATION

All vehicles except Élan.



Clutch alignment bar
(P/N 529 035 831)

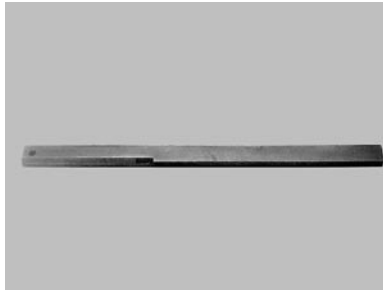

A33B034

APPLICATION

REV.

SECTION 09 - SERVICE TOOLS

SUSPENSION

Shock spring removal kit
(P/N 529 035 504)
Replacement clevis pin:
(P/N 414 528 400)

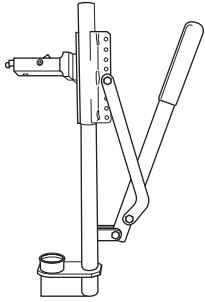

A01B404

APPLICATION

All suspensions with coil spring.

NOTE: The previous shock spring removal kit (P/N 529 027 100) can be upgraded by replacing the stopper with a wider stopper (P/N 529 035 551).

Track cleat remover
(P/N 529 028 700)

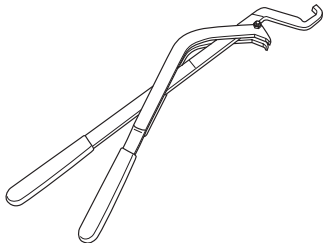

A01F224

APPLICATION

1994 and newer except Élan and Tundra II.

Camber angle tool
(P/N 529 021 600)

NOTE: Angle finder with a magnetic base must be used.

Suggestion: K-D tool no. 2968

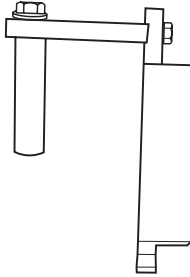

A06B024

APPLICATION

All DSA front suspensions.

Track tension gauge
(P/N 529 021 500)

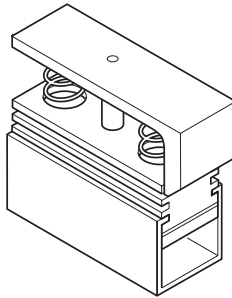

A00B3X4

APPLICATION

All models except Élan.

Track cleat installer
(P/N 529 028 800)

Narrow

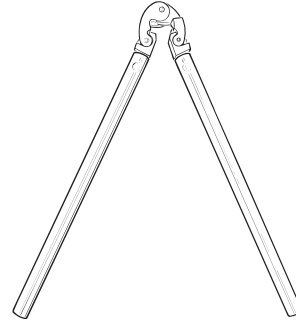

A01B1M4

APPLICATION

1994 and newer.

Dome guide

A) (P/N 529 026 500)

B) (P/N 529 035 728)

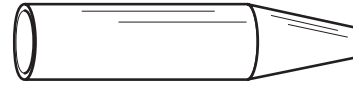

A06F1B4

APPLICATION

A) C-36 T/A shocks.

B) C-46 T/A shocks.

SUSPENSION (continued)

Shock wrench
(P/N 529 035 727)



A00F224

All T/A shocks except 2003 MX Zx 440.

Gas shock valve tool
(tire valve type)
(P/N 529 035 570)

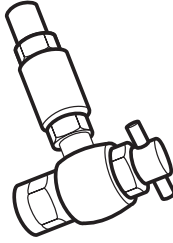

A02F134

APPLICATION
1999 and older T/A shocks and some 2000 and up T/A shocks.

NEW

A-arms nut wrench
(P/N 529 035 876)



A33B024

APPLICATION
REV.

HPG shock holding tool
(P/N 529 035 769)



A01B5H4

All HPG shocks

Tool for shock (needle type)
(P/N 529 035 614)



A00B5I4

APPLICATION
Most 2000 and up T/A shocks.

NEW

Ball joint remover
(P/N 529 035 877)



A33B074

APPLICATION
REV.

Piston guide
A) (P/N 529 026 600)
B) (P/N 529 035 608)

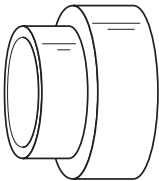

A06F1C4

APPLICATION
A) C-36 T/A shocks.
B) C-46 T/A shocks.

Adjustment wrench
(P/N 520 000 126)



A00B5H4

APPLICATION
SC-10 (coupling blocks).

SECTION 09 - SERVICE TOOLS

SUSPENSION (continued)

NEW

Ball joint remover support
(P/N 529 035 873)



V00B1J4

APPLICATION
REV.

A cylindrical metal component with a slightly wider top rim and a narrower body, used as a support for a ball joint remover.

NEW

Ball joint installer support
(P/N 529 035 875)



V00B1L4

APPLICATION
REV.

A simple cylindrical metal component used as a support for a ball joint installer.

NEW

Ball joint installer
(P/N 529 035 874)



V00B1K4

APPLICATION
REV.

A cylindrical metal component with a slightly wider top rim, used as a ball joint installer.

VEHICLE

Protective mat
(P/N 529 030 600)



A01B454

APPLICATION
All vehicles.

Snowmobile jack
(P/N 529 020 000)

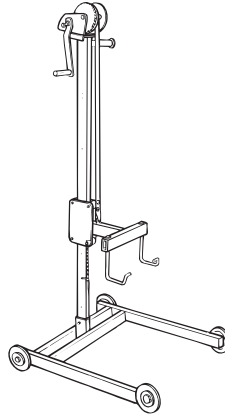

A01A1JJ

APPLICATION
All models.

Dolly
(P/N 529 029 900)

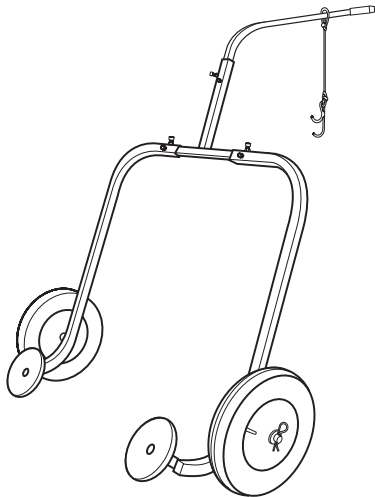

A00B4CJ

APPLICATION
All models.

Adjustment wrench
(P/N 529 035 603)



A32B044

APPLICATION
To remove and install fuel tank nut
on ZX series.

NEW

Filler neck nut wrench
(P/N 529 035 891)









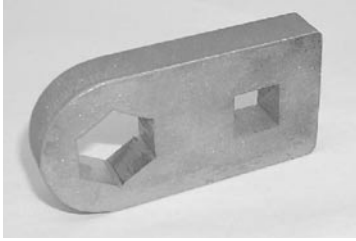

A33B084

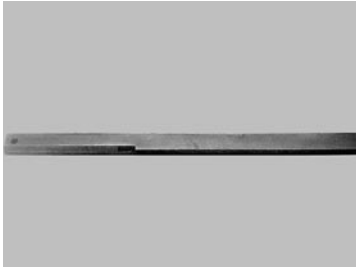
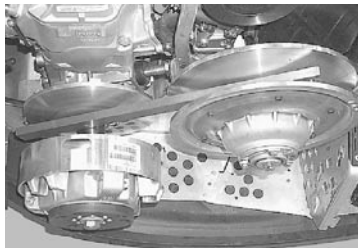
APPLICATION
REV.

SECTION 09 - SERVICE TOOLS

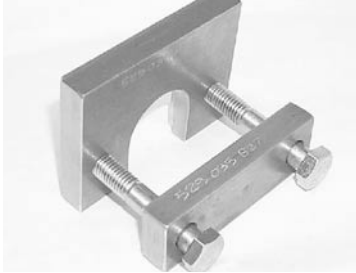
NEW TOOLS AND USAGE

| NEW TOOLS | USAGE | DESCRIPTION | P/N | MODEL |
|--|---|--|--------------------|------------|
|  |  | <p>A-arms nut wrench (SUSPENSION)</p> | <p>529 035 876</p> | <p>REV</p> |
|  |  | <p>Clutch alignment bar (TRANSMISSION)</p> | <p>529 035 831</p> | <p>REV</p> |
|  |  | <p>Engine removal hook (use with 529 035 830) (ENGINE)</p> | <p>529 035 829</p> | <p>REV</p> |
|  |  | <p>Spark plug lift ring (ENGINE)</p> | <p>529 035 830</p> | <p>REV</p> |
|  |  | <p>Ball joint remover (SUSPENSION)</p> | <p>529 035 827</p> | <p>REV</p> |

SECTION 09 - SERVICE TOOLS

| NEW TOOLS | USAGE | DESCRIPTION | P/N | MODEL |
|---|---|--|-------------|-------|
|  |  | Ball joint remover support (SUSPENSION) | 529 035 873 | REV |
|  |  | Ball joint installer (SUSPENSION) | 529 035 874 | REV |
|  |  | Ball joint installer support (SUSPENSION) | 529 035 875 | REV |
|  |  | Filler neck nut wrench (VEHICLE) | 529 035 891 | REV |

SECTION 10 - ACCESSORIES

| PART NUMBER | DESCRIPTION | MX Z 800HO (R) (X) | MX Z 600HO (R) (X) | MX Z 800HO (R) (ADRENALINE) | MX Z 600HO (R) (ADRENALINE) | MX Z X 440 (RACING) | MX Z 800HO (R) (RENEGADE X) | MX Z 600HO (R) (RENEGADE X) | MX Z 800HO (R) (RENEGADE) | MX Z 600HO (R) (RENEGADE) | MX Z 600HO SDI (R) (RENEGADE X) | SUMMIT 800HO (R) (HM XTREME) | SUMMIT 800HO (R) (HIGHMARK X) | SUMMIT 800HO (R) (HIGHMARK) | SUMMIT 800HO (R) (X) | SUMMIT 600HO (R) (X) | SUMMIT 800HO (R) (ADRENALINE) | SUMMIT 600HO (R) (ADRENALINE) |
|-------------|---|--------------------|--------------------|-----------------------------|-----------------------------|---------------------|-----------------------------|-----------------------------|---------------------------|---------------------------|---------------------------------|------------------------------|-------------------------------|-----------------------------|----------------------|----------------------|-------------------------------|-------------------------------|
| 861 784 100 | A arm protector Black for (REV) | X | X | X | X | X | X | X | X | X | X | X | X | X | X | X | X | X |
| 860 508 100 | A arm protector Orange for (REV) | X | X | X | X | X | X | X | X | X | X | X | X | X | X | X | X | X |
| 861 784 000 | A arm protector Yellow for (REV) | X | X | X | X | X | X | X | X | X | X | X | X | X | X | X | X | X |
| 517 302 803 | Body panel Black LH | X | X | X | X | X | X | X | X | X | X | X | X | X | X | X | X | X |
| 517 302 802 | Body panel Black RH | X | X | X | X | X | X | X | X | X | X | X | X | X | X | X | X | X |
| 517 302 805 | Body panel Yellow LH | X | X | X | X | X | X | X | X | X | X | X | X | X | X | X | X | X |
| 517 302 925 | Body panel Yellow RH | X | X | X | X | X | X | X | X | X | X | X | X | X | X | X | X | X |
| 507 032 329 | Braided Brake Hose | S | S | X | X | | S | S | X | X | S | S | S | S | S | S | X | X |
| 861 301 600 | Ceramic coated brake pads kit | X | X | X | X | | X | X | X | X | X | X | X | X | X | | X | X |
| 515 175 995 | Clear tail light | X | X | X | X | X | X | X | X | X | X | X | X | X | X | | X | X |
| 517 302 795 | Console Black (REV) | X | X | X | X | X | X | X | X | X | X | X | X | X | X | X | X | X |
| 517 302 797 | Console Orange (REV) | X | X | X | X | X | X | X | X | X | X | X | X | X | X | X | X | X |
| 517 302 845 | Console Yellow (REV) | X | X | X | X | X | X | X | X | X | X | X | X | X | X | X | X | X |
| 280 000 061 | Cover, canevas, (REV) 440 | | | | | X | | | | | | | | | | | | |
| 860 307 000 | Extension kit SC-10 (136) (REV X) | X | X | X | X | | | | | | | | | | | | | |
| 861 508 200 | Gauge, temperature, electric, White facia | X | X | X | X | | X | X | X | X | X | X | X | X | X | X | X | X |
| 860 603 000 | handguard kit, Acerbis Black | X | X | | | | X | X | | | X | | | | | | | |
| 860 602 700 | handguard kit, Acerbis Yellow | S | S | | | | S | S | | | S | | | | | | | |
| 517 302 788 | Hood Black (REV) | X | X | X | X | X | X | X | X | X | X | X | X | X | X | X | X | X |
| 517 302 790 | Hood Orange (REV) | X | X | X | X | X | X | X | X | X | X | X | X | X | X | X | X | X |
| 517 302 964 | Hood silver (REV) | X | X | X | X | X | X | X | X | X | X | X | X | X | X | X | X | X |
| 517 302 807 | Hood Yellow (REV) | X | X | X | X | X | X | X | X | X | X | X | X | X | X | X | X | X |
| 506 151 519 | J hook long 90 Black | X | X | X | X | X | X | X | X | X | X | X | X | X | X | X | X | X |

SECTION 10 - ACCESSORIES

| PART NUMBER | DESCRIPTION | MX Z 800HO (R) (X) | MX Z 600HO (R) (X) | MX Z 800HO (R) (ADRENALINE) | MX Z 600HO (R) (ADRENALINE) | MX Z X 440 (RACING) | MX Z 800HO (R) (RENEGADE X) | MX Z 600HO (R) (RENEGADE X) | MX Z 800HO (R) (RENEGADE) | MX Z 600HO (R) (RENEGADE) | MX Z 600HO SDI (R) (RENEGADE X) | SUMMIT 800HO (R) (HM XTREME) | SUMMIT 800HO (R) (HIGHMARK X) | SUMMIT 800HO (R) (HIGHMARK) | SUMMIT 800HO (R) (X) | SUMMIT 600HO (R) (X) | SUMMIT 800HO (R) (ADRENALINE) | SUMMIT 600HO (R) (ADRENALINE) |
|-------------|--|--------------------|--------------------|-----------------------------|-----------------------------|---------------------|-----------------------------|-----------------------------|---------------------------|---------------------------|---------------------------------|------------------------------|-------------------------------|-----------------------------|----------------------|----------------------|-------------------------------|-------------------------------|
| 506 151 503 | J hook long 90 Red | X | X | X | X | X | X | X | X | X | X | X | X | X | X | X | X | X |
| 506 151 505 | J hook long 90 Yellow | X | X | X | X | X | X | X | X | X | X | X | X | X | X | X | X | X |
| 506 151 520 | J hook short 45 Black | X | X | X | X | X | X | X | X | X | X | X | X | X | X | X | X | X |
| 506 151 502 | J hook short 45 Red | X | X | X | X | X | X | X | X | X | X | X | X | X | X | X | X | X |
| 506 151 504 | J hook short 45 Yellow | X | X | X | X | X | X | X | X | X | X | X | X | X | X | X | X | X |
| 506 151 596 | J hook Ultra, short 90 Black | S | S | | | | S | S | | | | S | S | S | S | S | S | S |
| 415 128 580 | J hook Ultra, short 90 Yellow | X | X | X | X | X | X | X | X | X | X | X | X | X | X | X | X | X |
| 506 151 593 | J hook Ultra, long 90 Black | S | S | | | | S | S | | | | S | S | S | S | S | S | S |
| 415 128 579 | J hook Ultra, long 90 Yellow | X | X | X | X | X | X | X | X | X | X | X | X | X | X | X | X | X |
| 861 786 300 | Jerry can kit (can, bracket, strap) | X | X | X | X | | X | X | X | X | X | S | S | S | S | S | X | X |
| 506 151 518 | J-Hook short 90x Black (B-160) | X | X | X | X | X | X | X | X | X | X | X | X | X | X | X | X | X |
| 861 784 200 | Knee pad (REV), Black | X | X | X | X | X | X | X | X | X | X | X | X | X | X | X | X | X |
| 861 784 400 | Knee pad (REV), Yellow | X | X | X | X | X | X | X | X | X | X | X | X | X | X | X | X | X |
| 861 802 500 | Nonskid strip kit, Black ((REV) X 2004 121") | X | X | X | X | X | | | | | | | | | | | | |
| 861 802 300 | Nonskid strip kit, Black ((REV) X 2004 136" to 159") | | | | | | X | X | X | X | X | X | X | X | X | X | X | X |
| 861 802 700 | Nonskid strip kit, Orange ((REV) X 2004 136" to 159") | | | | | | X | X | X | X | X | X | X | X | X | X | X | X |
| 861 802 600 | Nonskid strip kit, Yellow ((REV) X 2004 121") | X | X | X | X | X | | | | | | | | | | | | |
| 861 802 400 | Nonskid strip kit, Yellow ((REV) X 2004 136" to 159") | | | | | | X | X | X | X | X | X | X | X | X | X | X | X |
| 860 602 500 | Riser kit (REV) 2003 | | | X | X | | | | | | | | | | | | | |
| 860 427 800 | Roller secondary half | | | | | | | | | | | | | | | | | |
| 861 001 300 | Seat skin Rotax (REV) (short seat) | | | X | X | | | | X | X | | | | | | | | |

SECTION 10 - ACCESSORIES

| PART NUMBER | DESCRIPTION | MX Z 800HO (R) (X) | MX Z 600HO (R) (X) | MX Z 800HO (R) (ADRENALINE) | MX Z 600HO (R) (ADRENALINE) | MX Z X 440 (RACING) | MX Z 800HO (R) (RENEGADE X) | MX Z 600HO (R) (RENEGADE X) | MX Z 800HO (R) (RENEGADE) | MX Z 600HO (R) (RENEGADE) | MX Z 600HO SDI (R) (RENEGADE X) | SUMMIT 800HO (R) (HM XTREME) | SUMMIT 800HO (R) (HIGHMARK X) | SUMMIT 800HO (R) (HIGHMARK) | SUMMIT 800HO (R) (X) | SUMMIT 600HO (R) (X) | SUMMIT 800HO (R) (ADRENALINE) | SUMMIT 600HO (R) (ADRENALINE) |
|-------------|--|--------------------|--------------------|-----------------------------|-----------------------------|---------------------|-----------------------------|-----------------------------|---------------------------|---------------------------|---------------------------------|------------------------------|-------------------------------|-----------------------------|----------------------|----------------------|-------------------------------|-------------------------------|
| 415 128 670 | Seat snowcross XPS II (long seat) | X | X | | | | X | X | | | X | | | | | | | |
| 860 508 300 | Ski Mountain (Bridge & fasteners kit) | | | | | | | | | | | S | S | S | S | S | S | S |
| 505 071 391 | R.H. Ski plastic (Mountain), Black B-160 | | | | | | | | | | | S | S | S | S | S | S | S |
| 505 071 392 | Ski plastic (Mountain), Black B-160 | | | | | | | | | | | S | S | S | S | S | S | S |
| 505 071 406 | R.H. Ski plastic (Mountain), Yellow B-190 | | | | | | | | | | | X | X | X | X | X | X | X |
| 505 071 407 | Ski plastic (Mountain), Yellow B-190 | | | | | | | | | | | X | X | X | X | X | X | X |
| 505 070 242 | Ski plastic (Flex), Amethyst M-530 | X | X | X | X | S | X | X | X | X | X | | | | | | | |
| 505 070 189 | Ski plastic (Flex), Black B-160 | X | X | X | X | S | X | X | X | X | X | | | | | | | |
| 505 070 243 | Ski plastic (Flex), Blue B-182 | X | X | X | X | S | X | X | X | X | X | | | | | | | |
| 505 070 244 | Ski plastic (Flex), Viper Red B-176 | X | X | X | X | S | X | X | X | X | X | | | | | | | |
| 505 070 245 | Ski plastic (Flex), Yellow B-190 | X | X | X | X | S | X | X | X | X | X | | | | | | | |
| 505 070 727 | Ski plastic (Precision), Black B-160 | S | S | S | S | | S | S | S | S | S | | | | | | | |
| 505 070 831 | Ski plastic (Precision), Jaune B-190 | X | X | X | X | | X | X | X | X | X | | | | | | | |
| 505 070 832 | Ski plastic (Precision), Scarlet Red B-212 | X | X | X | X | | X | X | X | X | X | | | | | | | |
| 505 070 821 | Ski plastic (Flex) scarl. Red B212 | X | X | X | X | X | X | X | X | X | X | | | | | | | |
| 505 071 031 | Ski plastic (PRECISION), Blue B-226 | X | X | X | X | X | X | X | X | X | X | | | | | | | |
| 505 071 050 | Ski plastic (PRECISION), mix Black/Yellow | X | X | X | X | X | X | X | X | X | X | | | | | | | |

SECTION 10 - ACCESSORIES

| PART NUMBER | DESCRIPTION | MX Z 800HO (R) (X) | MX Z 600HO (R) (X) | MX Z 800HO (R) (ADRENALINE) | MX Z 600HO (R) (ADRENALINE) | MX Z X 440 (RACING) | MX Z 800HO (R) (RENEGADE X) | MX Z 600HO (R) (RENEGADE X) | MX Z 800HO (R) (RENEGADE) | MX Z 600HO (R) (RENEGADE) | MX Z 600HO SDI (R) (RENEGADE X) | SUMMIT 800HO (R) (HM XTREME) | SUMMIT 800HO (R) (HIGHMARK X) | SUMMIT 800HO (R) (HIGHMARK) | SUMMIT 800HO (R) (X) | SUMMIT 600HO (R) (X) | SUMMIT 800HO (R) (ADRENALINE) | SUMMIT 600HO (R) (ADRENALINE) |
|-------------|--|--------------------|--------------------|-----------------------------|-----------------------------|---------------------|-----------------------------|-----------------------------|---------------------------|---------------------------|---------------------------------|------------------------------|-------------------------------|-----------------------------|----------------------|----------------------|-------------------------------|-------------------------------|
| 505 071 051 | Ski plastic (PRECISION), Mix Yellow/ viper Red | X | X | X | X | X | X | X | X | X | X | | | | | | | |
| 505 071 052 | Ski plastic (PRECISION), Orange B-228 | X | X | X | X | X | X | X | X | X | X | | | | | | | |
| 860 507 700 | Ski PRECISION (Bridge & fasteners kit) | S | S | S | S | | S | S | S | S | S | | | | | | | |
| 505 070 863 | Ski runner (Montain) | | | | | | | | | | | | | | | | | |
| 860 508 400 | Ski runner (Carbides 5") Plastic ski (Mountain) | | | | | | | | | | | S | S | S | S | S | S | S |
| 860 506 800 | Ski runner (Carbides 10") Plastic ski (Flex) | | | | | | | | | | | | | | | | | |
| 860 503 500 | Ski runner 1/2" rod (Carbides 6") Plastic ski | | | | | | | | | | | | | | | | | |
| 860 503 200 | Ski runner 1/2" rod (Carbides 6") Plastic ski | | | | | | | | | | | | | | | | | |
| 860 503 400 | Ski runner 1/2" rod (Carbides 8") Plastic ski | | | | | | | | | | | | | | | | | |
| 860 503 300 | Ski runner 1/2" rod (Carbides 8") Plastic ski | | | | | | | | | | | | | | | | | |
| 860 502 700 | Ski runner -6" CARBIDE 1/2 60 deg. | | | | | | | | | | | | | | | | | |
| 860 506 600 | Ski runner -6" CARBIDE FLEX 1/2 60 deg. | | | | | | | | | | | | | | | | | |
| 860 505 200 | Ski runner 6"4" 60 degree, Precision | X | X | X | X | | X | X | X | X | X | | | | | | | |
| 860 505 100 | Ski runner 6"4" 90 degree, Precision | X | X | X | X | | X | X | X | X | X | | | | | | | |
| 502 006 743 | Skid plate, Black (REV) | X | X | X | X | X | X | X | X | X | X | X | X | X | X | X | X | X |
| 502 006 742 | Skid plate, Orange (REV) | X | X | X | X | X | X | X | X | X | X | X | X | X | X | X | X | X |
| 502 006 741 | Skid plate, Yellow (REV) | X | X | X | X | X | X | X | X | X | X | X | X | X | X | X | X | X |

SECTION 10 - ACCESSORIES

| PART NUMBER | DESCRIPTION | MX Z 800HO (R) (X) | MX Z 600HO (R) (X) | MX Z 800HO (R) (ADRENALINE) | MX Z 600HO (R) (ADRENALINE) | MX Z X 440 (RACING) | MX Z 800HO (R) (RENEGADE X) | MX Z 600HO (R) (RENEGADE X) | MX Z 800HO (R) (RENEGADE) | MX Z 600HO (R) (RENEGADE) | MX Z 600HO SDI (R) (RENEGADE X) | SUMMIT 800HO (R) (HM XTREME) | SUMMIT 800HO (R) (HIGHMARK X) | SUMMIT 800HO (R) (HIGHMARK) | SUMMIT 800HO (R) (X) | SUMMIT 600HO (R) (X) | SUMMIT 800HO (R) (ADRENALINE) | SUMMIT 600HO (R) (ADRENALINE) |
|-------------|---|--------------------|--------------------|-----------------------------|-----------------------------|---------------------|-----------------------------|-----------------------------|---------------------------|---------------------------|---------------------------------|------------------------------|-------------------------------|-----------------------------|----------------------|----------------------|-------------------------------|-------------------------------|
| 861 001 100 | Sled dolly 2 wheels | X | X | X | X | X | X | X | X | X | X | X | X | X | X | X | X | X |
| 861 000 800 | Sled shop wheels, Yellow | X | X | X | X | X | X | X | X | X | X | X | X | X | X | X | X | X |
| 520 000 343 | Snowguard (REV) X, Black | S | S | S | S | | S | S | S | S | S | | | | | | | |
| 520 000 412 | Snowguard (REV) X, Yellow | X | X | X | X | | X | X | X | X | X | | | | | | | |
| 860 306 500 | Suspension quick adjustment kit | X | X | X | X | | | | | | | | | | | | | |
| 861 770 400 | Track 15.0" X 121" (1.450") 36.8 mm kit | X | X | X | X | | | | | | | | | | | | | |
| 860 305 800 | Track 15.0" X 121" (1.750") 44.6 mm kit | X | X | X | X | | | | | | | | | | | | | |
| C9892H | Track 15X121X1.187 cone design | | | | | | | | | | | | | | | | | |
| C9921H | Track 15 X 121 X 1.25 rip saw | | | | | | | | | | | | | | | | | |
| C9882M | Track 15 X 144 X 2 paddle design | | | | | | | | | | | | | | | | | |
| C9871M | Track 15 X 144 X 2.25 finger design | | | | | | | | | | | | | | | | | |
| C9874C | Track 15 X 151 X 1.25 intense | | | | | | | | | | | | | | | | | |
| C9883M | Track 15 X 151 X 2 paddle design | | | | | | | | | | | | | | | | | |
| C9884M | Track 15 X 159 X 2 paddle design | | | | | | | | | | | | | | | | | |
| C9793T | Track, Challenger 15 X 121 X 1,000 | | | | | | | | | | | | | | | | | |
| C6799792 | Track, Challenger 15 X 121 X 1,187 | | | | | | | | | | | | | | | | | |
| C6799803 | Track, Challenger 15 X 121 X 1,500 | | | | | | | | | | | | | | | | | |
| C9800C | Track, Challenger 15 X 136 X 1,500 | | | | | | | | | | | | | | | | | |
| C6799842 | Track, Challenger 15 X 136 X 2,000 | | | | | | | | | | | | | | | | | |

SECTION 10 - ACCESSORIES

| PART NUMBER | DESCRIPTION | | | | | | | | | | | | | | | | | | |
|-------------|---|--------------------|--------------------|-----------------------------|-----------------------------|---------------------|-----------------------------|-----------------------------|---------------------------|---------------------------|---------------------------------|------------------------------|-------------------------------|-----------------------------|----------------------|----------------------|-------------------------------|-------------------------------|---|
| | | MX Z 800HO (R) (X) | MX Z 600HO (R) (X) | MX Z 800HO (R) (ADRENALINE) | MX Z 600HO (R) (ADRENALINE) | MX Z X 440 (RACING) | MX Z 800HO (R) (RENEGADE X) | MX Z 600HO (R) (RENEGADE X) | MX Z 800HO (R) (RENEGADE) | MX Z 600HO (R) (RENEGADE) | MX Z 600HO SDI (R) (RENEGADE X) | SUMMIT 800HO (R) (HM XTREME) | SUMMIT 800HO (R) (HIGHMARK X) | SUMMIT 800HO (R) (HIGHMARK) | SUMMIT 800HO (R) (X) | SUMMIT 600HO (R) (X) | SUMMIT 800HO (R) (ADRENALINE) | SUMMIT 600HO (R) (ADRENALINE) | |
| C9875M | Track, Challenger 15 X 144 X 2,000 | | | | | | | | | | | | | | | | | | |
| C6799871 | Track, Challenger 15 X 144 X 2,250 | | | | | | | | | | | | | | | | | | |
| C6799876 | Track, Challenger 15 X 151 X 2,000 | | | | | | | | | | | | | | | | | | |
| C6799872 | Track, Challenger 15 X 151 X 2,250 | | | | | | | | | | | | | | | | | | |
| C9808M | Track, Challenger 15 X 156 X 2,000 | | | | | | | | | | | | | | | | | | |
| C6799885 | Track, Challenger 15 X 159 X 2,250 | | | | | | | | | | | | | | | | | | |
| C9830H | Track, Predator 15 X 121 X 1,000 | | | | | | | | | | | | | | | | | | |
| C6909855 | Track, Predator 15 X 121 X 1,000 | | | | | | | | | | | | | | | | | | |
| C9854H | Track, Predator 15 X 121 X 1,250 | | | | | | | | | | | | | | | | | | |
| C6909818 | Track, Predator 15 X 121 X 1,250 | | | | | | | | | | | | | | | | | | |
| C6909856 | Track, Predator 15 X 136 X 1,000 | | | | | | | | | | | | | | | | | | |
| C6909819 | Track, Predator 15 X 136 X 1,250 | | | | | | | | | | | | | | | | | | |
| C9802R | Track, Predator racing 15 X 121 X 0,500 | | | | | | | | | | | | | | | | | | |
| C9811R | Track, Predator racing 15 X 121 X 0,540 | | | | | | | | | | | | | | | | | | |
| 861 302 200 | Translucent fuel tank w/bra, (REV) X | X | X | X | X | | | X | X | X | X | X | S | S | X | X | | X | X |
| 861 802 800 | Tunnel protector kit ((REV) X 121") | X | X | X | X | | | | | | | | | | | | | | |
| 861 80 3000 | Tunnel protector kit ((REV) X 136") | | | | | | | X | X | X | X | X | | | | | | | |
| 861 786 400 | Tunnel protector kit ((REV) X 121-136" 1-1/4") | X | X | X | X | | | X | X | X | X | X | | | | | | | |

SECTION 10 - ACCESSORIES

| PART NUMBER | DESCRIPTION | | | | | | | | | | | | | | | | | | |
|-------------|--------------------------------------|--------------------|--------------------|-----------------------------|-----------------------------|---------------------|-----------------------------|-----------------------------|---------------------------|---------------------------|---------------------------------|------------------------------|-------------------------------|-----------------------------|----------------------|----------------------|-------------------------------|-------------------------------|---|
| | | MX Z 800HO (R) (X) | MX Z 600HO (R) (X) | MX Z 800HO (R) (ADRENALINE) | MX Z 600HO (R) (ADRENALINE) | MX Z X 440 (RACING) | MX Z 800HO (R) (RENEGADE X) | MX Z 600HO (R) (RENEGADE X) | MX Z 800HO (R) (RENEGADE) | MX Z 600HO (R) (RENEGADE) | MX Z 600HO SDI (R) (RENEGADE X) | SUMMIT 800HO (R) (HM XTREME) | SUMMIT 800HO (R) (HIGHMARK X) | SUMMIT 800HO (R) (HIGHMARK) | SUMMIT 800HO (R) (X) | SUMMIT 600HO (R) (X) | SUMMIT 800HO (R) (ADRENALINE) | SUMMIT 600HO (R) (ADRENALINE) | |
| 860 306 800 | Wheel 165mm for rear suspension kit | | | | | S | | | | | | | | | | | | | |
| 860 306 900 | Wheel 180mm for rear suspension kit | X | X | X | X | | X | X | X | X | X | X | X | X | X | X | X | X | X |
| 517 303 020 | Windshield low fix swift, Black | X | X | | | X | X | X | | X | | | | | | | | | |
| 517 303 130 | Windshield low fix swift, fire Bee | X | X | | | X | X | X | | X | | | | | | | | | |
| 517 303 131 | Windshield low fix swift, piston Bee | X | X | | | X | X | X | | X | | | | | | | | | |
| 517 302 793 | Windshield (REV) (Low) | S | S | X | X | | | | | | | | | | | | | | |
| 517 302 843 | Windshield, high mobile (REV) | | | X | X | | | | X | X | | | | | | | | | |
| 517 302 617 | Windshield, low fix Black (REV) | | | | | S | | | | | | | | | | | | | |
| 415 128 570 | Windshield, low fix Yellow (REV) | | | | | X | | | | | | | | | | | | | |
| 517 302 814 | Windshield, med Black (REV) | | | X | X | | | | X | X | | | | | | | | | |

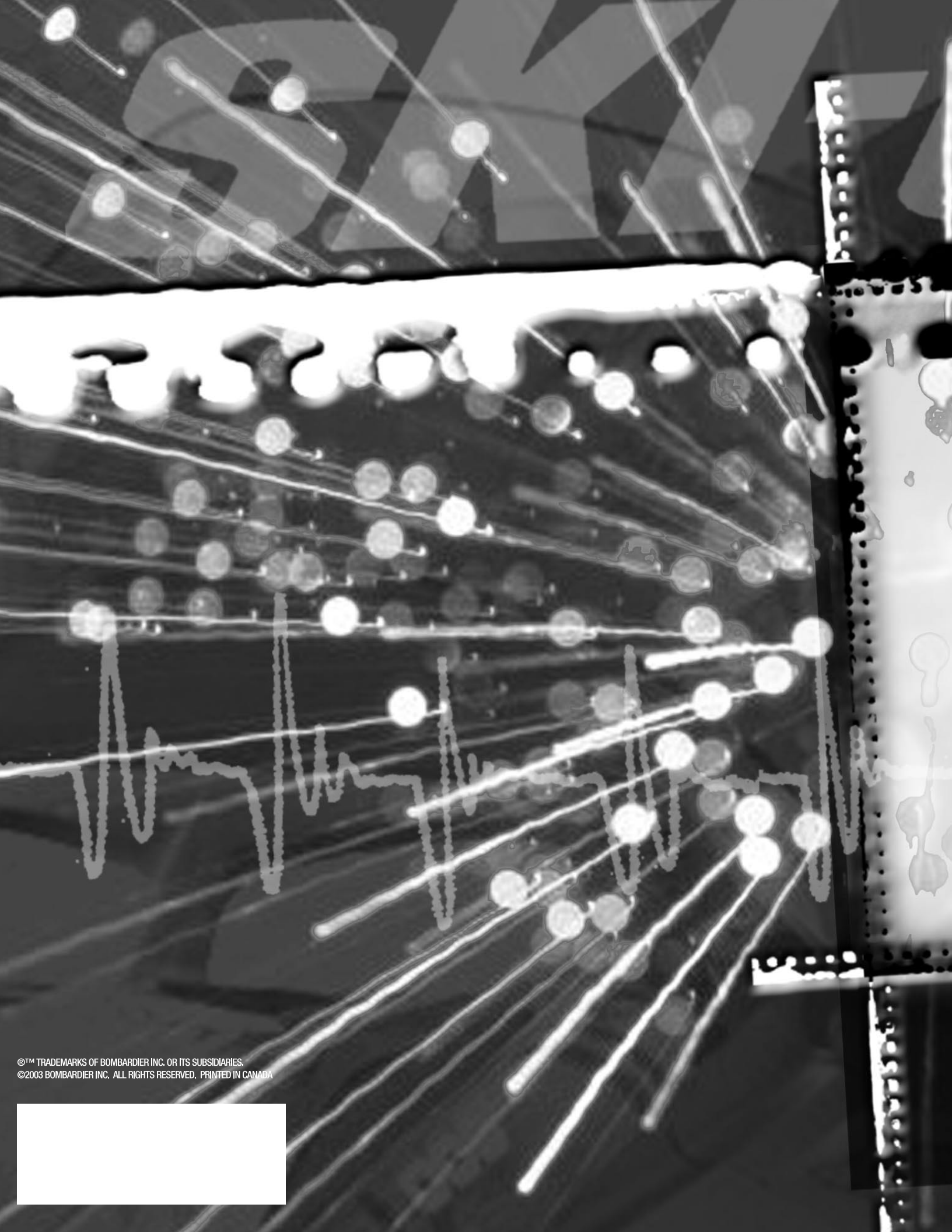

©™ TRADEMARKS OF BOMBARDIER INC. OR ITS SUBSIDIARIES.
©2003 BOMBARDIER INC. ALL RIGHTS RESERVED. PRINTED IN CANADA

