

# 2004 *ski-doo*®

## *Operator's Guide*

*Includes Safety,  
Vehicle and Maintenance  
Information*

# **SUPPLEMENT**

©™ TRADEMARKS OF BOMBARDIER INC. OR ITS SUBSIDIARIES.  
©2003 BOMBARDIER INC. ALL RIGHTS RESERVED. PRINTED IN CANADA.

This Supplement must be used in conjunction with  
2004 TUNDRA™ SKANDIC™ Series Operator's Guide  
(P/N 520 000 368).

## **SKANDIC™ EXPEDITION**

### **WARNING**

Read this supplement thoroughly. It contains important safety information.

Minimum recommended operator's age: 16 years old.

Minimum recommended passenger's age  
(if applicable): 16 years old.

Do not remove this Operator's Guide supplement from the vehicle.



4 8 4 2 0 0 0 6 0

## **SAFETY WARNING**

Disregarding any of the safety precautions and instructions contained in this *Operator's Guide Supplement*, *Safety Videocassette* or on-product warnings may result in injury, including the possibility of death.

This *Operator's Guide Supplement* and *Safety Videocassette* should remain with the unit at time of resale.

**BOMBARDIER**  
RECREATIONAL PRODUCTS



**Dear 2004 Skandic™ Expedition owner, in addition to the informations in the 2004 Tundra™ Skandic™ Series Operator's Guide (P/N 520 000 368), the following also applies to your model.**

---

# **BOMBARDIER LIMITED WARRANTY NORTH AMERICA: 2004 SKI-DOO® SNOWMOBILES**

## **1. SCOPE OF THE LIMITED WARRANTY**

In Canada, BOMBARDIER INC. (hereinafter "BOMBARDIER"), and in the USA, Bombardier on behalf of BOMBARDIER MOTOR CORPORATION OF AMERICA (BMCA) warrants its 2004 SKI-DOO snowmobiles from defects in material or workmanship for the period described below.

All genuine BOMBARDIER parts and accessories, installed by an authorized BOMBARDIER dealer (as hereinafter defined) at the time of delivery of the 2004 SKI-DOO snowmobile, carry the same warranty as that of the snowmobile.

Use of the product for racing or any other competitive activity, at any point, even by a prior owner will render this warranty null and void.

## **2. WARRANTY COVERAGE PERIOD**

This warranty will be in effect FROM THE DATE OF DELIVERY TO THE FIRST RETAIL CONSUMER or the date the product is first put into use, whichever occurs first and for a period of:

TWELVE (12) CONSECUTIVE MONTHS, for private or commercial use owners. The warranty coverage period on a snowmobile delivered between June 1<sup>st</sup> and December 1<sup>st</sup> of a given year will expire December 1<sup>st</sup> of the following year.

The emission-related components on EPA certified Skandic™ Expedition registered in the USA are covered for thirty (30) consecutive months or 2500 miles (4000 km) of engine use whichever occurs first. If the 2500 miles (4000 km) are reached during the regular warranty coverage period, the emission-related components are still on warranty until the end of regular warranty coverage period.

## Emission-Related Components

COMPONENT	ENGINE FAMILY (type)
	4-TEC V-1000
Throttle Position Sensor (TPS)	X
Air Temperature Sensor (ATS)	X
Air Pressure Sensor (APS)	X
Fuel Pressure Regulator	X
Fuel Injectors	X
Engine Management System (EMS)	X
Cylinder Head Rubber Rings/O-rings or Gasket	X
Crankcase Ventilation System	X

The repair or replacement of parts or the performance of service under this warranty does not extend the life of this warranty beyond its original expiration date.

### **3. CONDITIONS TO HAVE WARRANTY COVERAGE**

This warranty coverage is available only on 2004 SKI-DOO snowmobile purchased as new and unused by its first owner from a BOMBARDIER dealer authorized to distribute SKI-DOO products in the country in which the sale occurred (**hereinafter "BOMBARDIER dealer"**), and then only after the BOMBARDIER specified pre-delivery inspection process is completed and documented. Moreover, this warranty coverage is only available if the SKI-DOO snowmobile is purchased in the country in which the purchaser resides. Bombardier will not honor this limited warranty to any personal use owner or commercial use owner where the preceding conditions have not been met. Warranty coverage only becomes available upon proper registration of the product by a BOMBARDIER dealer. Such limitations are necessary in order to allow BOMBARDIER to preserve both the safety of its products, and also that of its consumers and the public. Routine maintenance outlined in the *Operator's Guide* must be timely performed in order to maintain warranty coverage. BOMBARDIER reserves the right to make warranty coverage contingent upon proof of proper maintenance.

### **4. WHAT TO DO TO OBTAIN WARRANTY COVERAGE**

The customer must notify a servicing BOMBARDIER dealer within two (2) days of the appearance of a defect, and provide it with reasonable access to the product and reasonable opportunity to repair it. The customer must also present to the BOMBARDIER dealer, proof of purchase of the product and must sign the repair/work order prior to the start of the repair in order to validate the warranty repair. All parts replaced under this limited warranty become the property of BOMBARDIER.

### **5. WHAT BOMBARDIER WILL DO**

BOMBARDIER's obligations under this warranty are limited to, at its sole discretion, repairing parts found defective under normal use, maintenance and service, or replacing such parts with new genuine BOMBARDIER parts without charge for parts and labor, at any authorized BOMBARDIER dealer.

BOMBARDIER reserves the right to improve or modify products from time to time without assuming any obligation to modify products previously manufactured.

## **6. EXCLUSIONS - ARE NOT WARRANTED**

- Normal wear and tear;
- Routine maintenance items, tune ups, adjustments;
- Damage caused by failure to provide proper maintenance and/or storage, as described in the *Operator's Guide*;
- Damage resulting from removal of parts, improper repairs, service, maintenance, modifications or use of parts not manufactured or approved by BOMBARDIER or resulting from repairs done by a person that is not an authorized servicing BOMBARDIER dealer;
- Damage caused by abuse, abnormal use, neglect, use of the product on surfaces other than snow, or operation of the product in a manner inconsistent with the recommended operation described in the *Operator's Guide*;
- Damage resulting from accident, submersion, fire, theft, vandalism or any act of God;
- Operation with fuels, oils or lubricants which are not suitable for use with the product (see the *Operator's Guide*);
- Snow or water ingestion;
- Incidental or consequential damages, or damages of any kind including without limitation towing, storage, telephone, rental, taxi, inconvenience, insurance coverage, loan payments, loss of time, loss of income; and
- Damage resulting from tracks which have been studded.

## **7. LIMITATIONS OF LIABILITY**

THIS WARRANTY IS EXPRESSLY GIVEN AND ACCEPTED IN LIEU OF ANY AND ALL OTHER WARRANTIES, EXPRESSED OR IMPLIED, INCLUDING WITHOUT LIMITATION ANY WARRANTY OF MERCHANTABILITY OR FITNESS FOR A PARTICULAR PURPOSE. TO THE EXTENT THAT THEY CANNOT BE DISCLAIMED, THE IMPLIED WARRANTIES ARE LIMITED IN DURATION TO THE LIFE OF THE EXPRESS WARRANTY. INCIDENTAL AND CONSEQUENTIAL DAMAGES ARE EXCLUDED FROM COVERAGE UNDER THIS WARRANTY. SOME STATES/PROVINCES DO NOT ALLOW FOR THE DISCLAIMERS, LIMITATIONS AND EXCLUSIONS IDENTIFIED ABOVE, AS A RESULT, THEY MAY NOT APPLY TO YOU. THIS WARRANTY GIVES YOU SPECIFIC RIGHTS, AND YOU MAY ALSO HAVE OTHER LEGAL RIGHTS WHICH MAY VARY FROM STATE TO STATE, OR PROVINCE TO PROVINCE.

Neither the distributor, any BOMBARDIER dealer nor any other person has been authorized to make any affirmation, representation or warranty regarding the product, other than those contained in this limited warranty, and if made, shall not be enforceable against BOMBARDIER.

BOMBARDIER reserves the right to modify this warranty at any time, being understood that such modification will not alter the warranty conditions applicable to the products sold while this warranty is in effect.

## **8. TRANSFER**

If the ownership of a product is transferred during the warranty coverage period, this warranty shall also be transferred and be valid for the remaining coverage period provided that BOMBARDIER is notified of such transfer of ownership in the following way:

- a. The former owner contacts BOMBARDIER (at the phone number provided below) or an authorized BOMBARDIER dealer and gives the coordinates of the new owner; or
- b. BOMBARDIER or an authorized BOMBARDIER dealer receives a proof that the former owner agreed to the transfer of ownership, in addition to the coordinates of the new owner.

## **9. CONSUMER ASSISTANCE**

- a. In the event of a controversy or a dispute in connection with this BOMBARDIER LIMITED WARRANTY, BOMBARDIER suggests that you try to resolve the issue at the dealership level. We recommend discussing the issue with the authorized dealer's service manager or owner.
- b. If the issue has not yet been resolved, please submit your complaint in writing or call the appropriate number below:

In Canada:

**BOMBARDIER INC.**  
**RECREATIONAL PRODUCTS**  
SKI-DOO®  
CUSTOMER ASSISTANCE CENTER  
VALCOURT QC J0E 2L0  
Tel.: (819) 566-3366

In USA:

**BOMBARDIER MOTOR**  
**CORPORATION OF AMERICA**  
**RECREATIONAL PRODUCTS**  
SKI-DOO®  
CUSTOMER ASSISTANCE CENTER  
7575 BOMBARDIER COURT  
WAUSAU WI 54401  
Tel.: (715) 848-4957



## Engine Serial Number Location

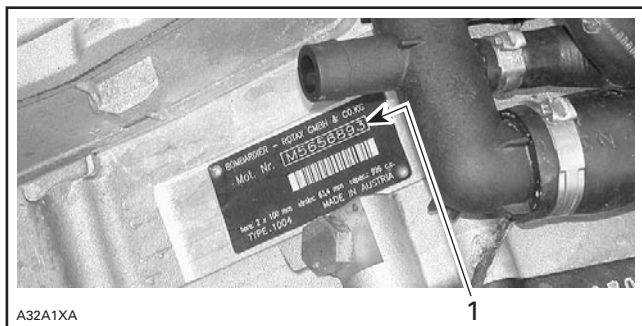

### SKANDIC EXPEDITION

1. Engine serial number

## ON-VEHICLE IMPORTANT INSTRUCTIONS

The following instructions are on your snowmobile. If missing or damaged, the decals can be replaced free of charge. See an authorized SKI-DOO dealer.

Please read the following instructions carefully before operating this snowmobile.

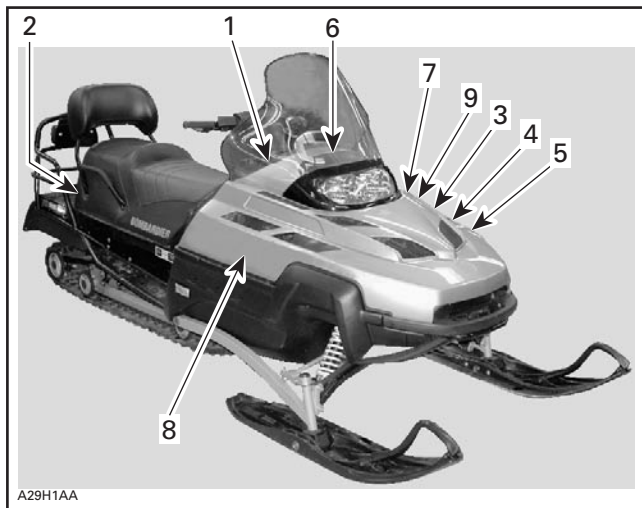

*TYPICAL — LOCATION OF IMPORTANT INSTRUCTIONS*

## WARNING

- Read and follow all warning labels & operator's guide/safety handbook before operation.
- Severe injury or death can result from ignoring warnings or through improper use of snowmobile.
- Before starting engine, check:
  - If throttle lever returns to its initial position when released.
  - All guards are in place.
- The hood is closed and the clutch access door is installed.
- Parking brake is applied.
- After starting, check proper operation of:
  - Engine emergency cut-off switch and all controls.
- Before operating the vehicle:
  - Make sure parking is fully disengaged.
  - Drive carefully.

- Lisez et respectez tous les avertissements contenus dans le guide du conducteur/guide de sécurité, avant toute mise en marche.
- Le fait de passer outre aux avertissements ou d'utiliser la moto/neige de façon inadéquate peut entraîner de graves blessures ou la mort.
- Avant de démarrer le moteur, s'assurer que:
  - La manette d'accélérateur revient à sa position initiale lorsque relâchée.
  - Les gardes soient en place.
  - Le capot soit fermé et le panneau d'accès de la poulie soit installé.
  - Le frein de stationnement soit appliqué.
- Après démarrage, s'assurer que:
  - L'interrupteur d'arrêt d'urgence du moteur et tous les contrôles fonctionnent normalement.
- Avant d'utiliser le véhicule:
  - S'assurer que le frein de stationnement soit complètement relâché.
  - Conduisez prudemment.

## AVERTISSEMENT

- Lisez et respectez tous les avertissements contenus dans le guide du conducteur/guide de sécurité, avant toute mise en marche.
- Le fait de passer outre aux avertissements ou d'utiliser la moto/neige de façon inadéquate peut entraîner de graves blessures ou la mort.
- Avant de démarrer le moteur, s'assurer que:
  - La manette d'accélérateur revient à sa position initiale lorsque relâchée.
  - Les gardes soient en place.
  - Le capot soit fermé et le panneau d'accès de la poulie soit installé.
  - Le frein de stationnement soit appliqué.
- Après démarrage, s'assurer que:
  - L'interrupteur d'arrêt d'urgence du moteur et tous les contrôles fonctionnent normalement.
- Avant d'utiliser le véhicule:
  - S'assurer que le frein de stationnement soit complètement relâché.
  - Conduisez prudemment.

516 001 229

## Instruction 2

### **WARNING**

- Check that the tow bar is securely fastened to the trailer coupling.
  - Use a rigid tow bar.
- Reduce speed when towing.

### **AVERTISSEMENT**

- Vérifier que la barre d'accouplement soit bien verrouillée à l'attache-remorque.
- Utiliser une barre d'accouplement rigide.
- Remorquer à vitesse réduite.

516 001 243

A05H1CA

## Instruction 3

### **CAUTION**

- To comply with noise regulations, this engine is designed to operate with an air intake silencer.
- Operation without air intake silencer or with one not properly installed may cause engine damage.

### **ATTENTION**

- Le moteur a été conçu pour fonctionner avec ce silencieux d'admission afin de se conformer aux lois et règlements relatifs au bruit.
- Son absence ou une mauvaise installation peut endommager le moteur.

516 001 191

A01A2EA

#### Instruction 4



#### Instruction 5



TYPICAL

## Instruction 6

### CAUTION

- Upshift only when engine is idling and speed is below 20 km/h (12 m.p.h.).
- Stop completely the vehicle before using reverse gear.
- Maximum speed in first gear 60 km/h (37 m.p.h.).

### ATTENTION

Changer les rapports avant seulement lorsque le régime du moteur est au ralenti et la vitesse inférieure à 20 km/h (12 m.p.h.).

- Arrêter complètement le véhicule avant de passer en marche arrière.
- Vitesse maximum en premier rapport 60 km/h (37 m.p.h.).

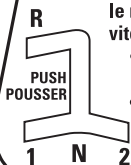

516 001 201

A29A01A

## Instruction 7

### ⚠ WARNING

Certain components in the engine compartment may be very hot. Direct contact may result in skin burn.

### ⚠ AVERTISSEMENT

Certaines composantes dans l'habitacle du moteur peuvent être très chaudes. Le contact direct sur la peau peut causer des brûlures.

516 001 297

A32A1GA

## Instruction 8



A32A1HA

TYPICAL

## Instruction 9

### EMISSION CONTROL INFORMATION

THIS ENGINE IS CERTIFIED TO OPERATE ON  
UNLEADED GASOLINE AND CONFORMS TO XXXX  
U.S. EPA REGULATIONS FOR SNOWMOBILE SI ENGINES.



ENGINE FAMILY: ..... XXXXXXXXXXXX  
FEL: ..... XXg/kW-hr HC+NO<sub>x</sub> XXXg/kW-hr CO  
ENGINE DISPLACEMENT: ..... XXXX cc  
EXHAUST EMISSION CONTROL SYSTEM: ..... XXX

#### TUNE-UP SPECIFICATIONS

IDLE SPEED: ..... XXXX RPM ± XXX  
SPARK PLUG TYPE: ..... XXXXXXXXXXXX  
SPARK PLUG GAP: ..... XXXX in/XXXX mm

A00A82A

TYPICAL

# CONTROLS/INSTRUMENTS/EQUIPMENT

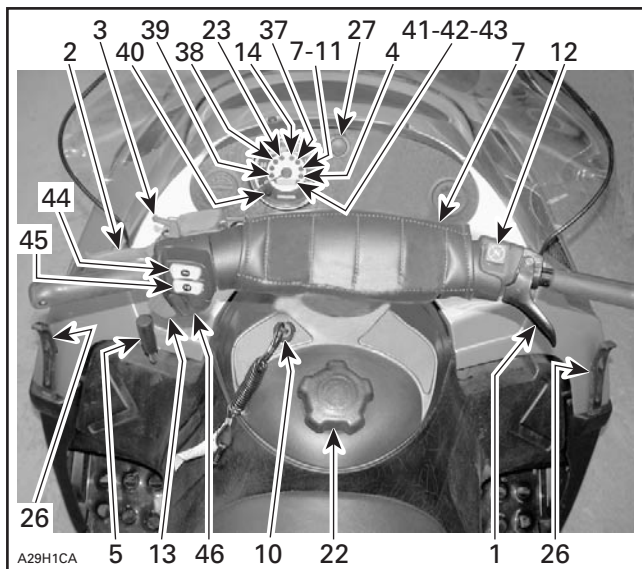
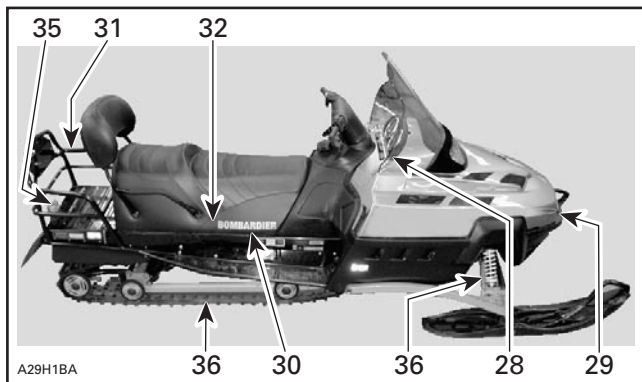

NOTE: See description of numbered items in *2004 Tundra Skandic Series Operator's Guide* (P/N 520 000 368) except for the following.



## 28) Fuses

To open fuse box push on cover tab and tilt cover. A fuse description decal is inside the cover.

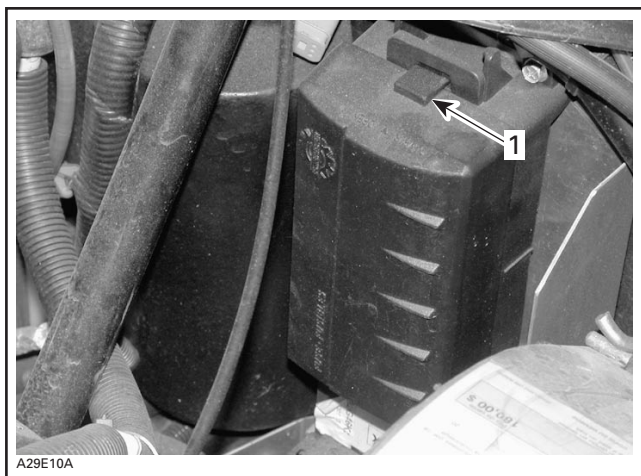

1. Cover tab

## 29) Front Grab Handle/Front Bumper

To be used whenever front of snowmobile requires manual lifting.

### **WARNING**

Do not attempt to lift the vehicle by hand alone. Use appropriate lifting device or have assistance to share lifting stress in order to avoid risk of strain injuries.

**CAUTION:** Do not use skis to pull or lift snowmobile.

## 37) Low Battery Voltage Pilot Lamp

This lamp will light up to indicate a low battery voltage condition. See an authorized SKI-DOO dealer as soon as possible.

### **38) Oil Pilot Lamp**

This pilot lamp will glow up when engine oil pressure is too low. Stop vehicle in a safe place then, check oil level and replenish as described in FLUID LEVEL.

Restart engine, oil pilot lamp must turn off after few seconds. If oil pilot lamp still glows up, stop engine and have lubrication system inspected by an authorized SKI-DOO dealer.

### **39) Engine Management System (EMS) Pilot Lamp**

This lamp will light up to indicate a trouble. Refer to TROUBLESHOOTING for trouble code meaning and remedy.

### **40) Mode Button**

Depress mode button to change display. Each time engine is started, display shows odometer. From that point depressing mode button will change display for the trip meter.

Depressing mode button again will change display for the resettable hourmeter. Push mode button again to return to odometer.

Push and hold mode button for 2 seconds to reset the tripmeter or the resettable hourmeter depending on the one displayed.

### **41) Odometer**

Odometer records the total distance travelled and displays it either in miles or kilometers. Refer to SPEEDOMETER for changing units.

**NOTE:** At vehicle speed of 90 km/h (55 MPH) and more the mode LCD screen will show speed only instead of the selected mode.

## 42) Trip Meter

Records distance travelled since it has been reset. Distance travelled is displayed either in miles or kilometers. Refer to SPEEDOMETER for changing units.

**NOTE:** At vehicle speed of 90 km/h (55 MPH) and more the mode LCD screen will show speed only instead of the selected mode.

## 43) Resetable Hour Meter

Records engine running time in hours and minutes since it has been reset.

**NOTE:** At vehicle speed of 90 km/h (55 MPH) and more the mode LCD screen will show speed only instead of the selected mode.

## 44) Heating Grip Switch

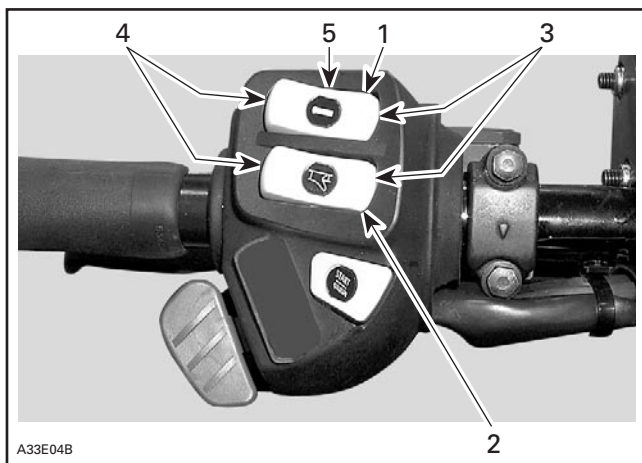

### TYPICAL

1. Heating grip switch
2. Heating throttle lever switch
3. Hot
4. Warm
5. Off

## 45) Heating Throttle Lever Switch

Three-position switch. Select the desired position to keep your right thumb at a comfortable temperature. See illustrations above.

## 46) Start Button

To start engine, push START button and hold until engine has started.

**CAUTION:** Do not hold START button more than 10 seconds. A rest period should be observed between the cranking cycles to let starter cool down. Holding START button when engine has started could damage starter mechanism.

Release START button immediately when engine has started.

If engine does not start on first try, wait a few seconds then repeat procedure. To stop engine, turn off engine cut-out switch or pull off tether cord cap.

---

## FUEL AND OIL

### Recommended Fuel

Use regular unleaded gasoline, available from most service stations or oxygenated fuel containing less than 10% of ethanol or 5% of methanol. The gasoline used must have an octane number  $(R + M)/2$  of 87 or higher.

**NOTE:** In most service station pump octane number corresponds to  $(R + M)/2$  octane number.

**CAUTION:** Never experiment with other fuels or fuel ratios. The use of unrecommended fuel can result in snowmobile performance deterioration and damage to critical parts in the fuel system and engine components.

### **WARNING**

Always stop the engine before refueling. Fuel is inflammable and explosive under certain conditions. Always work in a well ventilated area. Do not smoke or allow open flames or sparks in the vicinity. Open cap slowly. If a differential pressure condition is noticed (whistling sound heard when loosening fuel tank cap) have vehicle inspected and/or repaired before further operation. Do not overfill or top off the fuel tank before placing the vehicle in a warm area. As temperature increases, fuel expands and might overflow. Always wipe off any fuel spillage from the vehicle. Periodically verify fuel system.

## **Fuel System Antifreeze**

When using oxygenated fuel, additional gas line antifreeze or water absorbing additives are not required and should be not used.

When using non-oxygenated fuel, we highly recommend the use of isopropyl base gas line antifreeze in a proportion of 150 mL (5 U.S. oz) of gas line antifreeze added to 40 liters (10-1/2 U.S. gal) of gas.

This precaution is in order to reduce the risk of frost buildup in carburetor(s) which may lead, in certain cases, to high fuel consumption or severe damage to engine.

**NOTE:** Use only **methyl hydrate free** gas line antifreeze.

## **Recommended Oil**

Skandic Expedition is equipped with a 4-stroke engine.

Use BOMBARDIER 4-stroke synthetic oil 0W40 (P/N 293 600 054 — 12 x 1L).

**NOTE:** There is no known equivalent for this oil on the market for the moment. If a high quality equivalent were available, it could be used.

---

## BREAK-IN PERIOD

### Engine

**CAUTION:** A break-in period of 10 operating hours — 500 km (300 miles) — is required before running the snowmobile at full throttle.

During break-in period, maximum throttle should not exceed 3/4. However, brief full acceleration and speed variations contribute to a good break-in.

**CAUTION:** Engine overheating, continued wide open throttle runs and prolonged cruising without speed variations should be avoided, this can cause engine damage during the break-in period.

**CAUTION:** Do not add any oil to the first full filling of fuel tank as BOMBARDIER recommends for 2-stroke engines.

---

# OPERATING INSTRUCTIONS

## Starting the Engine

**IMPORTANT:** If the battery is dead, engine cannot be started. Have the battery recharged or replaced.

- Re-check throttle control lever operation.
- Ensure that the engine cut-out switch is in the ON position.
- Ensure that the tether cord cap is in position and that the cord is attached to your clothing eyelet.

### **WARNING**

Do not apply throttle while starting.

## Initial Cold Starting and Warm Engine Starting

Use electric starter.

## Emergency Starting

There is no emergency starting procedure for Skandic Expedition.







# PERIODIC MAINTENANCE CHART







## WARNING

Observe WARNINGS and CAUTIONS mentioned throughout this guide which are pertinent to the item being checked. When component conditions seem less than satisfactory, replace with genuine BOMBARDIER parts or approved equivalents.

Some items may not apply to your particular model. Refer to MAINTENANCE in *Shop Manual* for more details.

- ① 10-HOUR OR 500 km (300 miles) INSPECTION (to be performed by an authorized SKI-DOO dealer)
- ② WEEKLY OR EVERY 240 km (150 miles)
- ③ MONTHLY OR EVERY 800 km (500 miles)
- ④ ONCE A YEAR OR EVERY 3200 km (2000 miles)
- ⑤ ONCE A YEAR OR EVERY 6000 km (3700 miles)
- ⑥ STORAGE (to be performed by an authorized SKI-DOO dealer)
- ⑦ PRESEASON PREPARATION (to be performed by an authorized SKI-DOO dealer).

PERIODIC MAINTENANCE CHART		①	②	③	④	⑤	⑥	⑦
	Engine Nuts and Screws	I			I		I	
	Exhaust System	I		I			I	
	Engine Lubrication						L	
	Cooling System	I			I			I
	Coolant	I					R	
	Condition of Seals (3)							I
	Oil and Filter Replacement (4-TEC)					R		
	Fuel Stabilizer						R	
	Fuel Filter							R
	Fuel Lines and Connections	I					I	I
	Throttle Cable	I			I		I	I
	Air Filter			C				C
	Fuel Injection System (visual inspection)				I			
	Throttle Body Bores and Throttle Plates (3)							C

PERIODIC MAINTENANCE CHART		①	②	③	④	⑤	⑥	⑦
	Drive Belt	I	I					I
	Drive and Driven Pulleys	I		I	C		I	C
	Tightening Torque of Drive Pulley Screw	I			I			I
	Driven Pulley Preload	I			I		I	
	Brake Fluid	I	I				R	I
	Brake	I	I				I	I
	Gearbox Oil	R		I			R	I
	Drive Axle End Bearing (2)	L		L			L	
	Steering and Front Suspension Mechanism (2)	A,I,L		A,I	L		A,I,L	
	Wear and Condition of Skis and Runners	I	I				I	
	Suspension Adjustments	AS REQUIRED						
	Suspension (2)	I		I,L			I,L	
	Suspension Stopper Strap				I		I	
	Track	I		I			I	
	Track Tension and Alignment	A	AS REQUIRED					
	EMS Fault Codes (3)	I				I		
	Spark Plugs (1) (3)	I		I				R
	Battery	I		I			I	I
	Headlamp Beam Aiming				A			A
	Wiring Harnesses, Cables and Lines (3)	I		I			I	
	Operation of Lighting System (HI/LO beam, brake light, etc.), Test Operation of Engine Cut-Out Switch and Tether Cut-Out Switch	I	I				I	
	Rags in Air Intake and Exhaust System						R	C
	Engine Compartment	C		C			C	
	Vehicle Cleaning and Protection	C		C			C	

A = ADJUST

I = INSPECT (clean, inspect, repair, adjust and lubricate)

L = LUBRICATE

R = REPLACE

C = CLEAN

- (1) Before installing new spark plugs at pre-season preparation, it is suggested to burn excess storage oil by starting the engine with the old spark plugs. Only perform this operation in a well ventilated area.
- (2) Lubricate whenever the vehicle is used in wet conditions (wet snow, rain, puddles).
- (3) Emission-related

---

## FLUID LEVELS

### **WARNING**

It is recommended that the assistance of an authorized SKI-DOO dealer be periodically obtained on other components/systems not covered in this guide. Unless otherwise specified, engine must be cold and not running. Remove tether cord cap before performing any maintenance or adjustment, unless otherwise specified. Vehicle must be parked in a safe place, away from the trail.

**CAUTION:** Vehicle must be on a level surface before checking any fluid levels.

### **Engine Oil Level**

Make sure engine is at operating temperature.

Snowmobile must be on a level surface.

Leave engine running at idle for 30 seconds.

Stop engine and wipe the dipstick.

Dipstick must be completely screwed in before checking oil level.

Oil level must be between minimum and maximum marks on dipstick.

There is a capacity of 500 mL (17 U.S. oz) between the two marks.

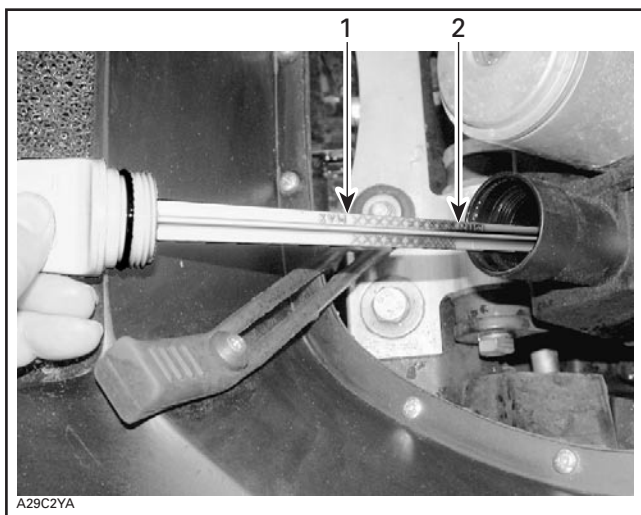

1. *Maximum*
2. *Minimum*

Add BOMBARDIER synthetic oil 0W40 through dipstick hole as required.

Reinstall dipstick.

## Cooling System

Check coolant level in expansion reservoir. When the engine is cold, the level must be between minimum and maximum marks.

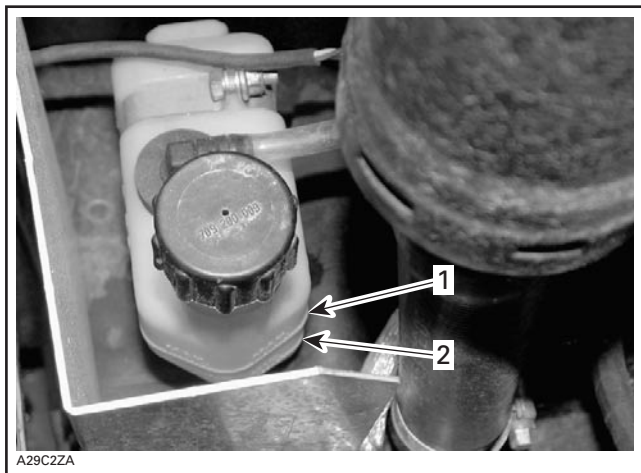

### EXPANSION RESERVOIR NEAR MUFFLER

1. Maximum
2. Minimum

## Battery Electrolyte

The Skandic Expedition is equipped with a maintenance-free battery. Electrolyte level can not be checked.

### **WARNING**

Battery BLACK negative cable must always be disconnected first and connected last.

### **WARNING**

Never charge or boost battery while installed. Battery electrolyte contains sulfuric acid which is corrosive and poisonous. In case of contact with skin, flush with water and call a physician immediately.

### **WARNING**

Should the battery casing be damaged, wear a suitable pair of non-absorbent gloves when removing the battery by hand.

**CAUTION:** Should any electrolyte spillage occur, immediately wash off with a solution of baking soda and water to prevent damage to vehicle components.

---

# **MAINTENANCE FOR EPA CERTIFIED ENGINES**

Maintenance, replacement, or repair of the emission control devices and systems may be performed by any snowmobile SI (spark ignition) engine repair establishments or individual.

## **Engine Emissions Information**

### **Manufacturer's Responsibility**

Beginning with 2004 model year engines, snowmobile manufacturers of snowmobile engines may determine the exhaust emission levels for each engine horsepower family and certify these engines with the United States of America Environmental Protection Agency (EPA). An emissions control information label, showing emission levels and engine specifications, must be placed on each vehicle at the time of manufacture.

Bombardier Recreational Products certified the following engine to applicable EPA snowmobile standards:

4-TEC V-1000

### **Dealer's Responsibility**

When performing service on all 2004 and more recent certified SKI-DOO snowmobiles that carry an emissions control information label, adjustments must be kept within published factory specifications.

Replacement or repair of any emission related component must be executed in a manner that maintains emission levels within the prescribed certification standards.

Dealers are not to modify the engine in any manner that would alter the horsepower or allow emission levels to exceed their predetermined factory specifications.

Exceptions include manufacturer's prescribed changes, such as altitude adjustments for example.

### **Owner Responsibility**

The owner/operator is required to have engine maintenance performed to maintain emission levels within prescribed certification standards.

The owner/operator is not to, and should not allow anyone to modify the engine in any manner that would alter the horsepower or allow emissions levels to exceed their predetermined factory specifications.

## **EPA Emission Regulations**

All new 2004 and more recent certified SKI-DOO snowmobiles manufactured by Bombardier are certified to the EPA as conforming to the requirements of the regulations for the control of air pollution from new snowmobile engines. This certification is contingent on certain adjustments being set to factory standards. For this reason, the factory procedure for servicing the product must be strictly followed and, whenever practicable, returned to the original intent of the design.

The responsibilities listed above are general and in no way a complete listing of the rules and regulations pertaining to the EPA requirements on exhaust emissions for snowmobile products. For more detailed information on this subject, you may contact the following locations:

### **VIA U.S. POSTAL SERVICE:**

Office of Mobile Sources  
Engine Programs and Compliance Division  
Engine Compliance Programs  
Group (6403J)  
401 M St. NW  
Washington, DC 20460

### **VIA EXPRESS or COURIER MAIL:**

Office of Mobile Sources  
Engine Programs and Compliance Division  
Engine Compliance Programs  
Group (6403J)  
501 3<sup>rd</sup> St. NW  
Washington, DC 20001

**EPA INTERNET WEB**

SITE: [www.epa.gov](http://www.epa.gov)



---

## MAINTENANCE

### **WARNING**

It is recommended that the assistance of an authorized SKI-DOO dealer be periodically obtained on other components/systems not covered in this guide. Unless otherwise specified, engine must not be running and cold. Remove tether cord cap before performing any maintenance or adjustment, unless otherwise specified. Vehicle must be parked in a safe place, away from the trail.

### **Belt Guard Removal and Installation**

#### **WARNING**

Engine should be running only when belt guard is secured in place.

**NOTE:** Belt guard is purposely made slightly oversize to maintain tension on its pins and retainers preventing undue noise and vibration. It is important that this tension be maintained when reinstalling.

1. Remove tether cord cap. Open engine compartment.
2. Loosen collar screw on air silencer grommet.
3. Disconnect engine vent hose from air silencer.
4. Disconnect air temperature sensor.
5. Unhook latch from air silencer. Remove air silencer.

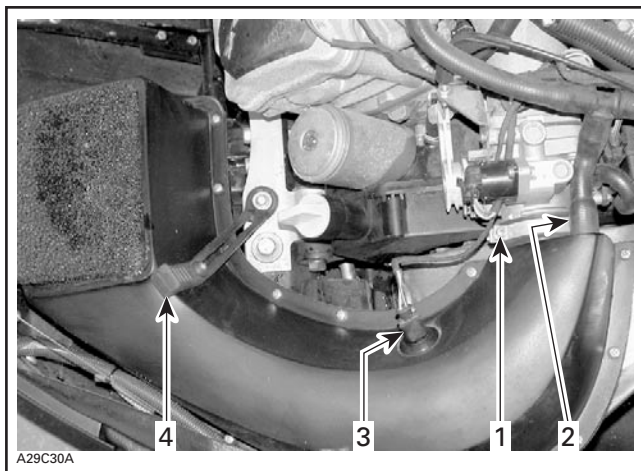

1. Collar screw
2. Vent hose
3. air temperature sensor
4. Latch

6. Refer to *Tundra Skandic Series Operator's Guide* (P/N 520 000 368) and follow Skandic SUV 600 procedure to remove belt guard.

At installation do not forget to connect air temperature sensor otherwise a trouble code will appear.

## Air Filter Cleaning

Check that the air silencer is clean and dry and properly reinstall the filter.

**CAUTION:** Snowmobile engines have been calibrated with the filters installed. Operating the snowmobile without them may cause engine damage.

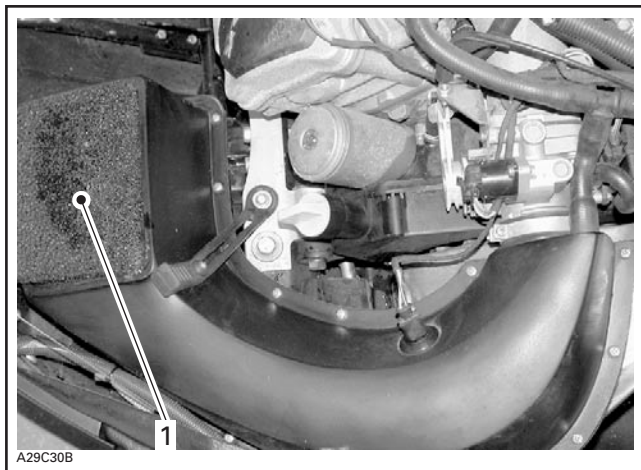

1. Air filter

## Drive Pulley Adjustment

### **WARNING**

Remove tether cord cap before performing any maintenance or adjustment, unless otherwise specified. Vehicle must be parked in a safe place, away from the trail.

### General

From factory TRA drive pulley adjustment screws are set to position 4. This position allows the best compromise between acceleration, top speed and fuel economy.

Position 2 or 3 would provide the best fuel economy. Top speed would be reduced.

Position 5 would give the best acceleration. Fuel economy would be reduced.

## Adjustment

Just loosen locking nut enough to pull calibration screw **partially** out and adjust to desired position. Do not completely remove the locking nut. Torque locking nuts to 10 N•m (89 lbf•in).

**CAUTION:** Do not completely remove calibration screw otherwise inside washer will fall off. Always adjust all 3 calibration screws and make sure they are all set at the same number.

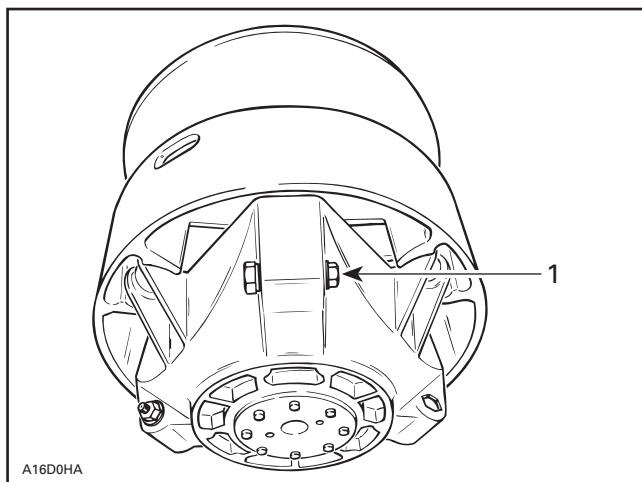

A16D0HA

### TYPICAL

1. Loosen just enough to permit rotating of calibrate screw

## **WARNING**

Always reinstall belt guard. Do not operate engine with hood open or belt guard removed. Improper servicing, modification or poor adjustment may affect drive pulley performance and belt life. Always refer to the *Shop Manual* or obtain SKI-DOO dealer advice before servicing or modifying the drive or driven pulleys. Always respect maintenance schedules.

# TROUBLESHOOTING

## Monitoring Beeper Coded Signals

CODED SIGNALS	POSSIBLE CAUSE	REMEDY
2 short beeps (when engine is started). DESS/RER pilot lamp also blinks.	Confirms that proper tether cord cap is installed. Engine can rev above pulley engagement.	Normal condition.
1 short beep every 1.5 seconds (when engine is started). DESS/RER pilot lamp also blinks. Engine cannot reach pulley engagement speed. Vehicle cannot be driven.	Bad DESS system connection.  Defective tether cord cap.  Dirt or snow in tether cord cap.  Defective DESS post.	Reinstall tether cord cap correctly over post.  Use another programmed tether cord cap.  Clean tether cord cap.  Replace DESS post.
1 long beep per second.	Reverse is selected.	Vehicle can be driven in reverse.
3 short beeps per second. DESS/RER pilot lamp also blinks. Engine cannot reach pulley engagement speed. Vehicle cannot be driven.	Wrong tether cord cap is installed.	Install proper tether cord cap. Program key into electronic module.

CODED SIGNALS	POSSIBLE CAUSE	REMEDY
3 short beeps per second. Engine overheating pilot lamp also blinks.	Engine is overheating.	Stop engine immediately and allow to cool. Check cooling system.
3 short beeps per second. Oil pilot lamp also lights up.	Low oil pressure.	Stop engine immediately and check oil level and top it. Check lubrication system.
3 short beeps per second.	Low battery voltage.	Check battery and charging system.
Battery pilot lamp lights up.	No charging.	Check battery and charging system.
4 short beeps every 2 minutes.	Too high battery voltage.  DESS system has detected a shorted key installed on DESS post.	Check battery and charging system.  Use another programmed tether cord cap.

# SPECIFICATIONS

MODEL		SKANDIC EXPEDITION
<b>Engine</b>		
– Maximum power engine speed	± 100 RPM	7250
<b>Drive Belt</b>		
– Part number		605 348 425
– Wear limit width	mm (in)	35.5 (1.398)
<b>Spark Plug</b>		
– Type		NGK DCPR8E
– Gap	± 0.05 mm (± .002 in)	0.80 (.031)
<b>Track</b>		
– Tension	mm (in)	40 - 50 (1-9/16 - 1-31/32) ①
– Alignment		②
<b>Fuel</b>		
– Type		③
– Tank capacity	L (U.S. gal)	45 (11.9)
<b>Oil (engine)</b>		
– Type		④
– Tank capacity	L (U.S. oz)	3.4 (115)
<b>Gearbox Oil</b>		
– Type		⑤
– Capacity	mL (U.S. oz)	400 (13.5)
<b>Cooling System</b>		
– Type		⑥
– Capacity	L (U.S. oz)	4.5 (152)
<b>Brake System Fluid</b>		
– Type		DOT 4 ⑦

① to ⑦ and N.A.: See at end of specifications.

Because of its ongoing commitment to product quality and innovation, Bombardier reserves the right, at any time, to make changes in design and specifications and/or to make additions to, or improvements in its products without imposing any obligation upon itself to install them on its products previously manufactured.

- ① Measure gap between slider shoe and bottom inside of track when exerting a downward pull of 7.3 kg (16 lb) to the track.
- ② Equal distance between edges of track guides and slider shoes.
- ③ Regular unleaded gasoline with a minimum octane number of 87  $(R + M)/2$ .
- ④ BOMBARDIER 4-stroke synthetic oil 0W40 (P/N 293 600 054 — 12 x 1L).
- ⑤ Bombardier synthetic chaincase oil (P/N 413 803 300 — 12 x 355 mL).
- ⑥ Bombardier premixed coolant (P/N 413 711 802 — 16 x 1 L).
- ⑦ SRF (DOT 4) (P/N 293 600 063) or GTLMA (DOT 4) (P/N 293 600 062).

N.A.: Not applicable