

**Bombardier Recreational Products Inc.**

# ***ski-doo***® ***2005***

## ***Operator's Guide***

***Includes  
Safety, Vehicle  
and Maintenance  
Information***



***SUPPLEMENT***

©™ TRADEMARKS OF BOMBARDIER RECREATIONAL PRODUCTS INC. OR ITS AFFILIATES.  
\* TRADEMARKS OF BOMBARDIER INC. USE UNDER LICENSE.  
©2004 BOMBARDIER RECREATIONAL PRODUCTS INC. ALL RIGHTS RESERVED. PRINTED IN CANADA.

This Supplement must be used in conjunction with  
2005 TUNDRA™ /SKANDIC™ Series Operator's Guide  
(P/N 520 000 477).

## ***SKANDIC™ EXPEDITION 600 H.O. SDI / V-1000***

### **WARNING**

Read this supplement thoroughly. It contains important  
safety information.

Minimum recommended operator's age: 16 years old.  
Do not remove this Operator's Guide Supplement from  
the vehicle.

5 2 0 0 0 0 5 0 5

## SAFETY WARNING

Disregarding any of the safety precautions and instructions contained in this *Operator's Guide*, *Safety Videocassette* or on-product warnings may result in injury, including the possibility of death.

This *Operator's Guide* and *Safety Videocassette* should remain with the unit at time of resale.



In USA, products are distributed by BRP US Inc.  
In Canada, products are distributed by Bombardier Recreational Products Inc.

The following trademarks are the property of Bombardier Recreational Products Inc.:

Skandic™

Rotax®

XP-S™

Tundra™

Dear 2005 Skandic™ Expedition owner, in addition to the informations in the *2005 Tundra™ Skandic™ Series Operator's Guide* (P/N 520 000 477), the following also applies to your model.

---

# TABLE OF CONTENTS

## **VEHICLE INFORMATION**

<b>HOW TO IDENTIFY YOUR SNOWMOBILE .....</b>	<b>6</b>
Engine Serial Number Location.....	6
<b>ON-VEHICLE IMPORTANT INSTRUCTIONS.....</b>	<b>7</b>
<b>CONTROLS/INSTRUMENTS/EQUIPMENT .....</b>	<b>14</b>
28) Fuses .....	15
29) Front Grab Handle/Front Bumper.....	15
37) Low Battery Voltage Pilot Lamp .....	15
38) Oil Pilot Lamp .....	16
39) Engine Management System (EMS) Pilot Lamp.....	16
40) Mode Button .....	16
41) Odometer .....	16
42) Trip Meter .....	16
43) Resetable Hour Meter .....	17
44) Heating Grip Switch.....	17
45) Heating Throttle Lever Switch.....	17
46) Start Button .....	17
<b>FUEL AND OIL .....</b>	<b>19</b>
Recommended Fuel .....	19
Recommended Oil .....	20
<b>BREAK-IN PERIOD .....</b>	<b>22</b>
Engine .....	22
<b>OPERATING INSTRUCTIONS.....</b>	<b>23</b>
Starting the Engine.....	23
Emergency Starting .....	23

## **MAINTENANCE INFORMATION**

<b>PERIODIC MAINTENANCE CHART.....</b>	<b>28</b>
<b>FLUID LEVELS .....</b>	<b>31</b>
Chaincase/Gearbox Oil Level .....	31
Oil Injection System.....	32
Engine Oil Level .....	33
Cooling System .....	34
Battery Electrolyte .....	36
<b>MAINTENANCE FOR EPA CERTIFIED ENGINES .....</b>	<b>37</b>
Engine Emissions Information.....	37

<b>MAINTENANCE</b> .....	<b>39</b>
Belt Guard Removal and Installation .....	39
Air Filter Cleaning .....	40
Drive Pulley Adjustment .....	41
<b>TROUBLESHOOTING</b> .....	<b>43</b>
Monitoring Beeper Coded Signals.....	43
<b>SPECIFICATIONS</b> .....	<b>45</b>

### ***WARRANTY***

<b>BRP LIMITED WARRANTY NORTH AMERICA: 2005 SKI-DOO® SNOWMOBILES</b> .....	<b>50</b>
<b>BRP INTERNATIONAL LIMITED WARRANTY: 2005 SKI-DOO® SNOWMOBILES</b> .....	<b>56</b>
<b>PRIVACY OBLIGATIONS/DISCLAIMER</b> .....	<b>60</b>
<b>CHANGE OF ADDRESS OR OWNERSHIP</b> .....	<b>61</b>

# ***VEHICLE INFORMATION***

# HOW TO IDENTIFY YOUR SNOWMOBILE

## Engine Serial Number Location

600 H.O. SDI

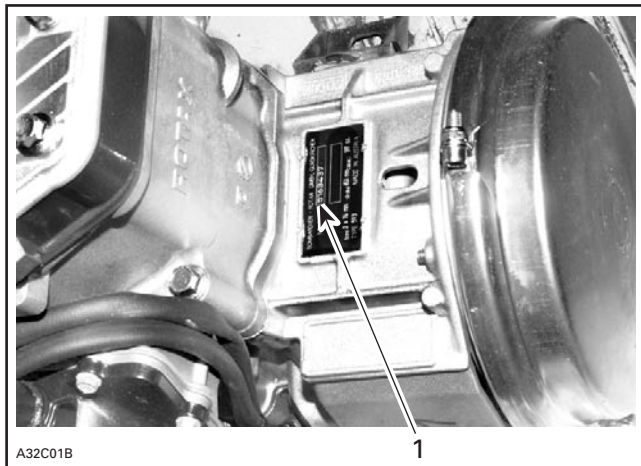

1. Engine serial number

V-1000

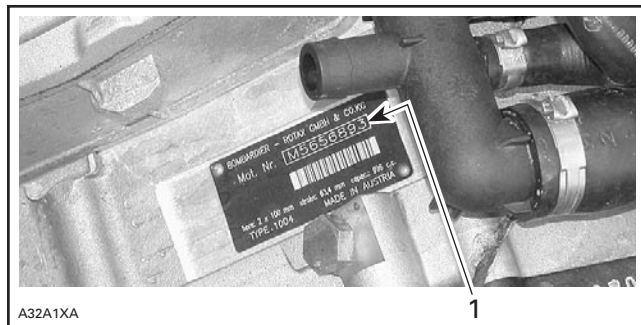

1. Engine serial number

# ON-VEHICLE IMPORTANT INSTRUCTIONS

The following instructions are on your snowmobile. If missing or damaged, the decals can be replaced free of charge. See an authorized SKI-DOO dealer.

Please read the following instructions carefully before operating this snowmobile.

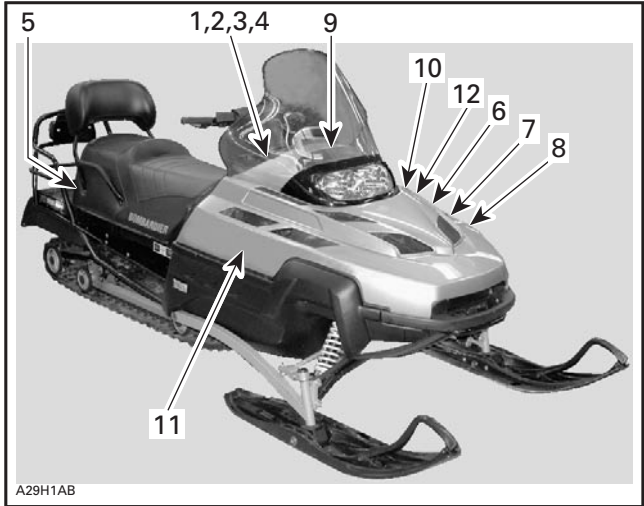

A29H1AB

TYPICAL — LOCATION OF IMPORTANT INSTRUCTIONS

## Instruction 1

<p><b>⚠ WARNING</b>  <b>ALL DRIVERS AND PASSENGERS MUST READ THE FOLLOWING:</b>          Avoid surprises!  <b>BE ON THE LOOK-OUT</b> for the unexpected.          Operate defensively.          • Scan constantly for people, objects, conditions and upcoming vehicles.          • Avoid thin ice / open water.          • Use extra caution whenever off trail.</p>	<p><b>⚠ AVERTISSEMENT</b>  <b>TOUS LES CONDUCTEURS ET PASSAGERS DOIVENT LIRE CE QUI SUIT:</b>          Évitez les surprises! <b>SOYEZ AUX AGUETS</b> pour les imprévus.          Conduisez défensivement.          • Scrutez constamment pour repérer personnes, objets, conditions et autres véhicules.          • Évitez la glace mince / étendue d'eau non gelée          • Redoublez de vigilance hors sentier.</p>
<p><b>ALWAYS</b> wear a DOT approved <b>HELMET</b> and clothing appropriate for snowmobiling.</p>	<p><b>TOUJOURS</b> porter un <b>CASQUE</b> approuvé DOT et des vêtements appropriés à la motoneige.</p>
<p><b>NEVER</b> ride after consuming alcohol or drugs even as a passenger.</p>	<p>Ne <b>JAMAIS</b> utiliser une motoneige sous l'influence de drogues ou alcool même en tant que passager.</p>

A00A8SA 5160093



## Instruction 2

### ⚠ WARNING

#### BEFORE STARTING :

1. **Attach tether cord** to your clothing.
2. **Check proper operation of the throttle and brake levers** each time before starting. They must return to their initial position when released.
3. **Apply parking brake.**
4. **Turn handlebars all the way in both directions** to check for interference and insure free operation.

- AFTER STARTING:**
1. **Pull-out tether cord** to check if engine shuts off.
  2. **Re-start and push in engine cut-off switch** to check if engine shuts off.
  3. **Disengage parking brake** before riding to avoid fading.

### ⚠ AVERTISSEMENT

#### AVANT DE DÉMARRER :

1. **Attachez le cordon coupe-circuit** à votre vêtement.
2. **Vérifiez le bon fonctionnement des manettes d'accélérateur et de frein** avant chaque démarrage. Elles doivent revenir à leur position initiale lorsque relâchées.
3. **Engagez le frein de stationnement.**
4. **Tournez le guidon au maximum de chaque côté** pour vérifier les interférences et le libre fonctionnement.

#### APRÈS LE DÉMARRAGE :

1. **Déconnectez le cordon coupe-circuit** pour vérifier qu'il arrête le moteur.
2. **Redémarrez et enfoncez le bouton d'arrêt d'urgence** pour vérifier qu'il arrête le moteur.
3. **Désengagez le frein de stationnement** avant le départ pour éviter la surchauffe et la perte du frein.

A00A8TA

## Instruction 3

### ⚠ AVERTISSEMENT

- **Lire et comprendre toutes les étiquettes d'avertissements et le guide du conducteur avant utilisation.**

Si le guide est introuvable, demandez-en un nouveau à votre concessionnaire.

- **Familiarisez-vous avec votre motoneige.**

Les motoneigistes inexpérimentés peuvent sous-estimer les risques et être surpris par le comportement spécifique de la motoneige et des conditions du terrain. Conduisez lentement.

- **La vitesse excessive et la conduite irresponsable peuvent causer la mort ! TOUJOURS adapter votre vitesse** selon les conditions de neige et les circonstances environnantes.

- **Le contrôle de la direction et le freinage peuvent être réduits** sur la neige compactée, la glace ou les routes. Réduisez votre vitesse et allouez plus d'espace pour tourner ou freiner.

- **Respectez les lois sur l'âge minimal du conducteur.**

Le fabricant recommande que le conducteur soit âgé d'au moins **16 ans**.

516002694

### ⚠ WARNING

**Read and understand all warning labels and operator's guide before operation.** If guide is missing, ask your dealer for a new one.

- **Get familiar with your snowmobile.**

Inexperienced riders may overlook risks and be surprised by snowmobile's specific behavior and terrain conditions.  
Ride slowly.

- **Excessive speed and reckless driving can kill ! ALWAYS adjust your speed according to snow conditions and circumstances.**

- **Steering control and braking ability may be reduced** on hard-pack snow, ice or roads. Reduce speed & allow more space to stop or turn.

- **Respect laws on minimum operator age.**

Manufacturer recommends a minimum operating age of **16 years old**.

A00A8UA

## Instruction 4

<b>⚠ WARNING</b>	<b>⚠ AVERTISSEMENT</b>
<p>This vehicle is designed for one (1) operator and as many passengers as there are seats with straps or handgrips installed on the vehicle conforming to SSCC standards.</p> <p>When riding with a passenger :</p> <ul style="list-style-type: none"><li>• Braking ability and steering control are reduced.</li></ul> <p><b>Decrease speed</b> and allow extra space to maneuver.</p> <ul style="list-style-type: none"><li>• <b>Adjust suspensions</b> according to weight.</li></ul> <p>REMEMBER : YOU ARE RESPONSIBLE FOR THE SAFETY OF YOUR PASSENGER!</p>	<p>Ce véhicule a été conçu pour un (1) conducteur et autant de passagers qu'il y a de sièges avec courroies ou poignées installés sur le véhicule et rencontrant la norme SSCC.</p> <p>Lors de la conduite avec passager :</p> <ul style="list-style-type: none"><li>• La capacité de freinage et la direction sont réduites.</li></ul> <p><b>Réduisez votre vitesse</b> et prévoyez plus d'espace pour manœuvrer.</p> <ul style="list-style-type: none"><li>• <b>Ajustez les suspensions</b> selon le poids.</li></ul> <p>N'DOUBLIEZ PAS : VOUS ÊTES RESPONSABLE DE LA SÉCURITÉ DE VOTRE PASSAGER!</p>
A00A8VA	516002692

## Instruction 5

<b>⚠ WARNING</b>
<ul style="list-style-type: none"><li>• <b>Check that the tow bar is securely fastened to the trailer coupling.</b><ul style="list-style-type: none"><li>• Use a rigid tow bar.</li></ul></li><li>• <b>Reduce speed when towing.</b></li></ul>
<b>⚠ AVERTISSEMENT</b>
<ul style="list-style-type: none"><li>• <b>Vérifier que la barre d'accouplement soit bien verrouillée à l'attache-remorque.</b></li><li>• <b>Utiliser une barre d'accouplement rigide.</b><ul style="list-style-type: none"><li>• <b>Remorquer à vitesse réduite.</b></li></ul></li></ul>
516 001 243
A05H1CA

## Instruction 6

### **CAUTION**

- To comply with noise regulations, this engine is designed to operate with an air intake silencer.
- Operation without air intake silencer or with one not properly installed may cause engine damage.

### **ATTENTION**

- Le moteur a été conçu pour fonctionner avec ce silencieux d'admission afin de se conformer aux lois et règlements relatifs au bruit.
- Son absence ou une mauvaise installation peut endommager le moteur.

516 001 191

A01A2EA

## Instruction 7

### **WARNING**

This guard must always  
be in place when engine is running.

### **AVERTISSEMENT**

Ce garde-courroie doit toujours être  
en place lorsque le moteur fonctionne.

516 001 190

A01A2FA

## Instruction 8



TYPICAL

## Instruction 9

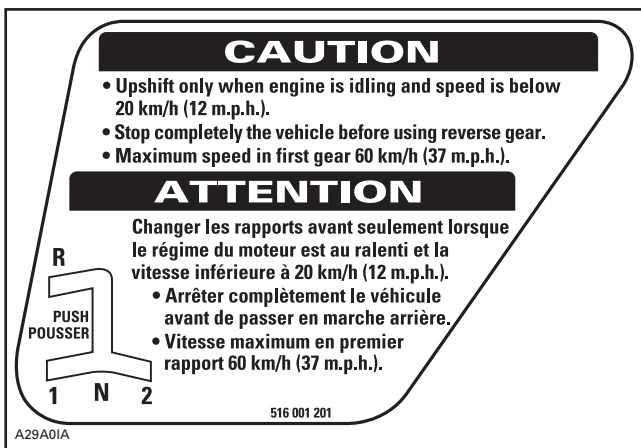

## Instruction 10

### **⚠ WARNING**

Certain components in the engine compartment may be very hot. Direct contact may result in skin burn.

### **⚠ AVERTISSEMENT**

Certaines composantes dans l'habitacle du moteur peuvent être très chaudes. Le contact direct sur la peau peut causer des brûlures.

516 001 297

A32A1GA

## Instruction 11



A32A1HA

TYPICAL

## Instruction 12

### EMISSION CONTROL INFORMATION

THIS ENGINE IS CERTIFIED TO OPERATE ON  
UNLEADED GASOLINE AND CONFORMS TO XXXX  
U.S. EPA REGULATIONS FOR SNOWMOBILE SI ENGINES.

ENGINE FAMILY: ..... XXXXXXXXXXXXX  
FEL: ..... XXg/kW-hr HC+NO<sub>x</sub> XXXg/kW-hr CO  
ENGINE DISPLACEMENT:..... XXXX cc  
EXHAUST EMISSION CONTROL SYSTEM: ..... XXX

#### TUNE-UP SPECIFICATIONS

IDLE SPEED: ..... XXXX RPM ± XXX  
SPARK PLUG TYPE: ..... XXXXXXXXXXXXX  
SPARK PLUG GAP: ..... XXXX in/XXXX mm

A00A8RA

*TYPICAL*

## CONTROLS/INSTRUMENTS/EQUIPMENT

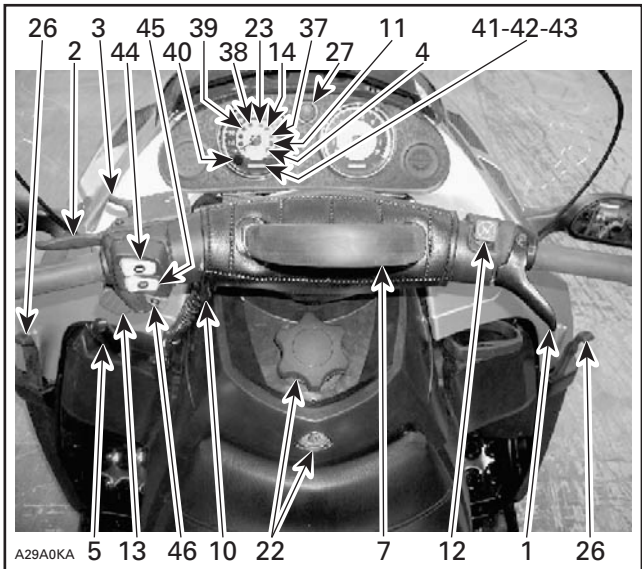
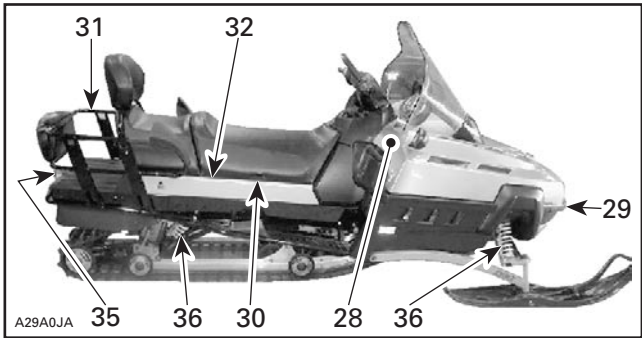

**NOTE:** See description of numbered items in *Tundra Skandic Series Operator's Guide* (P/N 520 000 477) except for the following.

## 28) Fuses

To open fuse box push on cover tab and tilt cover. A fuse description decal is inside the cover.

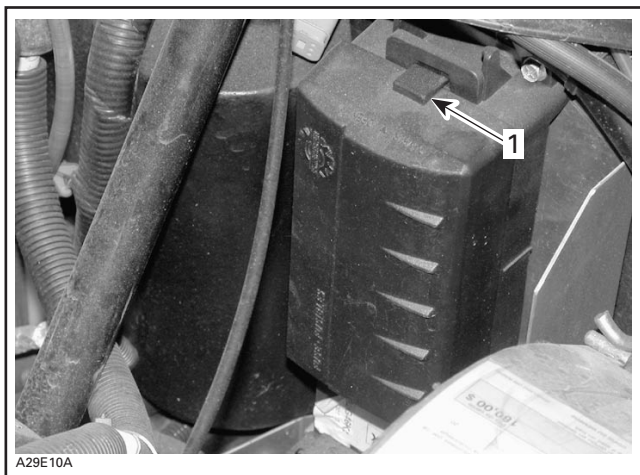

1. Cover tab

## 29) Front Grab Handle/Front Bumper

To be used whenever front of snowmobile requires manual lifting.

### **WARNING**

Do not attempt to lift the vehicle by hand alone. Use appropriate lifting device or have assistance to share lifting stress in order to avoid risk of strain injuries.

**CAUTION:** Do not use skis to pull or lift snowmobile.

## 37) Low Battery Voltage Pilot Lamp

This lamp will light up to indicate a low battery voltage condition. See an authorized SKI-DOO dealer as soon as possible.



## **38) Oil Pilot Lamp**

### **600 H.O. SDI**

This pilot lamp will glow up when injection oil level is low. Stop vehicle in a safe place then, replenish injection oil reservoir.

### **V-1000**

This pilot lamp will glow up when engine oil pressure is too low. Stop vehicle in a safe place then, check oil level and replenish as described in FLUID LEVEL.

Restart engine, oil pilot lamp must turn off after few seconds. If oil pilot lamp still glows up, stop engine and have lubrication system inspected by an authorized SKI-DOO dealer.

## **39) Engine Management System (EMS) Pilot Lamp**

This lamp will light up to indicate a trouble. Refer to TROUBLESHOOTING for trouble code meaning and remedy.

## **40) Mode Button**

Depress mode button to change display. Each time engine is started, display shows odometer. From that point depressing mode button will change display for the trip meter.

Depressing mode button again will change display for the resettable hourmeter. Push mode button again to return to odometer.

Push and hold mode button for 2 seconds to reset the tripmeter or the resettable hourmeter depending on the one displayed.

## **41) Odometer**

Odometer records the total distance travelled and displays it either in miles or kilometers. Refer to SPEEDOMETER for changing units.

**NOTE:** At vehicle speed of 90 km/h (55 MPH) and more the mode LCD screen will show speed only instead of the selected mode.

## **42) Trip Meter**

Records distance travelled since it has been reset. Distance travelled is displayed either in miles or kilometers. Refer to SPEEDOMETER for changing units.

**NOTE:** At vehicle speed of 90 km/h (55 MPH) and more the mode LCD screen will show speed only instead of the selected mode.

### 43) Resetable Hour Meter

Records engine running time in hours and minutes since it has been reset.

**NOTE:** At vehicle speed of 90 km/h (55 MPH) and more the mode LCD screen will show speed only instead of the selected mode.

### 44) Heating Grip Switch

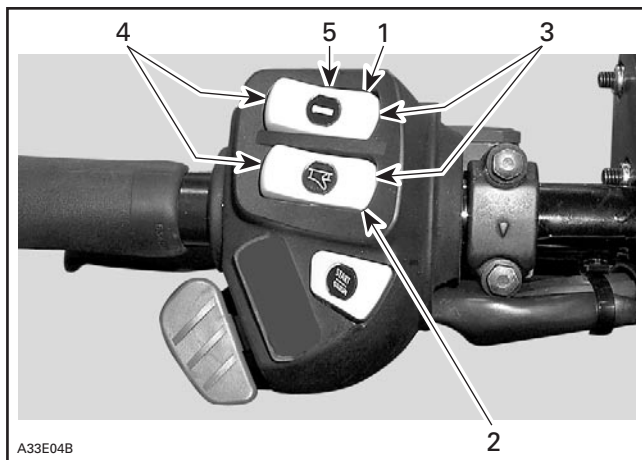

**TYPICAL**

1. Heating grip switch
2. Heating throttle lever switch
3. Hot
4. Warm
5. Off

### 45) Heating Throttle Lever Switch

Three-position switch. Select the desired position to keep your right thumb at a comfortable temperature. See illustrations above.

### 46) Start Button

To start engine, push START button and hold until engine has started.

**CAUTION:** Do not hold START button more than 10 seconds. A rest period should be observed between the cranking cycles to let starter cool down. Holding START button when engine has started could damage starter mechanism.

Release START button immediately when engine has started.

If engine does not start on first try, wait a few seconds then repeat procedure. To stop engine, turn off engine cut-out switch or pull off tether cord cap.

---

## FUEL AND OIL

### Recommended Fuel

Use regular unleaded gasoline, available from most service stations or oxygenated fuel containing less than 10% of ethanol or 5% of methanol. The gasoline used must have the following recommended minimum octane number.

LOCATION	OCTANE NUMBER
Inside North America	87 (RON + MON)/2
Outside North America	91 RON

**CAUTION:** Never experiment with other fuels or fuel ratios. The use of unrecommended fuel can result in snowmobile performance deterioration and damage to critical parts in the fuel system and engine components.

### WARNING

Always stop the engine before refueling. Fuel is flammable and explosive under certain conditions. Always work in a well ventilated area. Do not smoke or allow open flames or sparks in the vicinity. Open cap slowly. If a differential pressure condition is noticed (whistling sound heard when loosening fuel tank cap) have vehicle inspected and/or repaired before further operation. Do not overfill or top off the fuel tank before placing the vehicle in a warm area. As temperature increases, fuel expands and might overflow. Always wipe off any fuel spillage from the vehicle. Periodically verify fuel system.

### Fuel System Antifreeze

When using oxygenated fuel, additional gas line antifreeze or water absorbing additives are not required and should be not used.

When using non-oxygenated fuel, we highly recommend the use of isopropyl base gas line antifreeze in a proportion of 150 mL (5 U.S. oz) of gas line antifreeze added to 40 liters (10-1/2 U.S. gal) of gas.

This precaution is in order to reduce the risk of frost buildup in fuel system which may lead, in certain cases, to high fuel consumption or severe damage to engine.

**NOTE:** Use only methyl hydrate free gas line antifreeze.

## Recommended Oil

### 600 H.O. SDI

**CAUTION:** Use only injection oil that flows at - 40°C (- 40°F). Do not mismatch oil reservoir cap with fuel tank cap. Oil reservoir cap is identified OIL.

Oil is contained in the injection oil reservoir.

Use only two-stroke engine injection oil sold by an authorized SKI-DOO dealers.

MODEL	OIL TYPE
600 H.O. SDI <sup>(1)</sup>	XP-S™ synthetic 2-stroke oil <sup>(2)</sup> OR XP-S™ 2-stroke synthetic blend <sup>(2)</sup>

**CAUTION: (1)** XP-S synthetic 2-stroke oil and XP-S 2-stroke synthetic blend oil are specially formulated and tested for the severe requirements of these engines. Use of any other brand two-stroke oil may void the limited warranty. Use only XP-S synthetic 2-stroke oil or XP-S 2-stroke synthetic blend. There is no known equivalent on the market for the moment. If a high quality equivalent were available, it could be used.

**(2)** XP-S synthetic 2-stroke, and XP-S 2-stroke synthetic blend injection oil are compatible, they can be mixed together.

The XP-S 2-stroke synthetic blend and XP-S synthetic 2-stroke oil provides superior lubrication, reduced engine component wear and oil deposit, thus maintaining maximum-level performance and antifriction properties. These synthetic and synthetic blend injection oil meets the latest ASTM and JASO standards by ensuring high biodegradability and low exhaust smoke.

**CAUTION:** Never use four-stroke petroleum or synthetic motor oil and never mix these with outboard motor oil. Do not use NMMA TC-W, TC-W2 or TC-W3 outboard two-stroke engine oils or ashless two-stroke engine oils. Avoid mixing different brands of API TC oil as resulting chemical reactions may cause severe engine damage.

Always maintain a sufficient amount of recommended oil in the injection oil reservoir.

**CAUTION:** Check level and refill every time you refuel. Do not mismatch oil reservoir cap with fuel tank cap. Install cap that is identified OIL.

 **WARNING**

Do not overfill. Reinstall cap and fully tighten. Wipe off any oil spills. Oil is highly flammable.

**V-1000**

With V-1000 use XP-S 0W40 synthetic 4-stroke oil (P/N 293 600 054).

**NOTE:** There is no known equivalent for this oil on the market for the moment. If a high quality equivalent were available, it could be used.

---

## BREAK-IN PERIOD

### Engine

**CAUTION:** A break-in period of 10 operating hours or 500 km (300 miles) is required before running the snowmobile at full throttle.

During break-in period, maximum throttle should not exceed 3/4. However, brief full acceleration and speed variations contribute to a good break-in.

**CAUTION:** Engine overheating, continued wide open throttle runs and prolonged cruising without speed variations should be avoided, this can cause engine damage during the break-in period.

#### ***600 H.O. SDI***

To assure additional protection during the initial engine break-in, 500 mL (17 U.S. oz) of recommended injection oil should be added to fuel for the first full filling of fuel tank. Have spark plugs cleaned after engine break-in.

#### ***V-1000***

**CAUTION:** Do not add any oil to the first full filling of fuel tank as BRP recommends for 2-stroke engines.

---

# OPERATING INSTRUCTIONS

## Starting the Engine

- Recheck throttle control lever operation.
- Ensure that the engine cut-out switch is in the ON position.
- Ensure that the tether cord cap is in position and that the cord is attached to your clothing eyelet.

**NOTE:** On the **600 H.O. SDI**, if the low battery voltage pilot lamp is on, battery would not have enough power to start the engine. In this case, use the manual rewind starter.

**NOTE:** On either models, **600 H.O. SDI** or **V-1000**, if the battery is dead, engine cannot be started. Have the battery recharged or replaced.

### **WARNING**

Never depress throttle when starting engine.

## Emergency Starting

### **V-1000**

There is no emergency starting procedure for this engine type.

### **600 H.O. SDI**

The engine can be started with the emergency starter rope supplied with the tool kit.

Remove belt guard.

### **WARNING**

Do not wind starting rope around your hand. Hold rope by the handle only. Do not start the snowmobile by the drive pulley unless it is a true emergency situation. Have the snowmobile repaired as soon as possible.





A07D0UA

Attach one end of emergency rope to rewind handle.

**NOTE:** The spark plug socket can be used as an emergency handle.

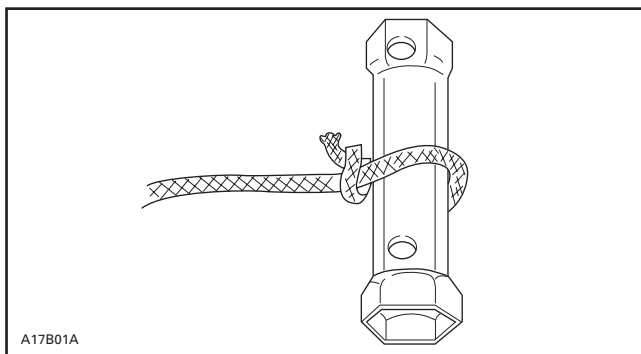

A17B01A

*TYPICAL*

Attach the other end of emergency rope to the starter clip supplied in the tool kit.

Hook up clip on drive pulley.

Wind the rope tightly around drive pulley. When pulled, pulley must rotate counterclockwise.

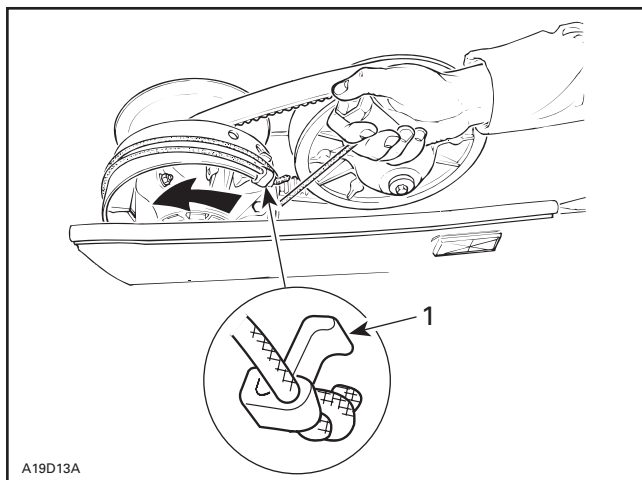

**TYPICAL**

**1. Clip**

Pull the rope using a sharp, crisp pull so the rope comes free of the drive pulley.

Start engine as per usual manual starting.

**⚠ WARNING**

When starting the snowmobile in an emergency situation, using drive pulley, do not reinstall the belt guard and return slowly to have snowmobile repaired.

# ***MAINTENANCE INFORMATION***

## PERIODIC MAINTENANCE CHART

### **WARNING**

Observe **WARNINGS** and **CAUTIONS** mentioned throughout this guide which are relevant to the item being checked. When component conditions seem less than satisfactory, replace with genuine BRP parts or approved equivalents.

Some items may not apply to your particular model. Refer to **MAINTENANCE** in *Shop Manual* for more details.

- (1) 10-HOUR OR 500 km (300 m.) INSPECTION  
(to be performed by an authorized SKI-DOO dealer).
- (2) WEEKLY OR EVERY 240 km (150 m.).
- (3) MONTHLY OR EVERY 800 km (500 m.).
- (4) ONCE A YEAR OR EVERY 3200 km (2000 m.).
- (5) ONCE A YEAR OR EVERY 6000 km (3700 m.).
- (6) STORAGE (to be performed by an authorized SKI-DOO dealer).
- (7) PRESEASON PREPARATION  
(to be performed by an authorized SKI-DOO dealer).

<b>PERIODIC MAINTENANCE CHART</b>	(1)	(2)	(3)	(4)	(5)	(6)	(7)
<b>ENGINE</b>							
Engine Nuts and Screws	I			I		I	
Exhaust System	I		I			I	
Engine Lubrication						L	
Cooling System	I			I			I
Coolant	I					R	
Condition of Seals (3)						I	I
Oil and Filter Replacement (V-1000)					R		
Rave Valves (3) (600 H.O. SDI)					R		
Injection Oil Filter (600 H.O. SDI)			I			R	
Injection Pump (600 H.O. SDI)	A			A			A

<b>PERIODIC MAINTENANCE CHART</b>	(1)	(2)	(3)	(4)	(5)	(6)	(7)
<b>FUEL SYSTEM</b>							
Fuel Stabilizer						R	
Fuel Filter							R
Fuel Lines and Connections	I					I	I
Throttle Cable	I			I		I	I
Air Filter			C				C
Fuel Injection System (visual inspection)				I			
Throttle Body Bores and Throttle Plates (3)							C
<b>DRIVE</b>							
Drive Belt	I	I					I
Drive and Driven Pulleys	I		I	C		I	C
Tightening Torque of Drive Pulley Screw	I			I			I
Driven Pulley Preload	I			I		I	
<b>BRAKE</b>							
Brake Fluid	I	I				R	I
Brake	I	I				I	I
<b>TRANSMISSION</b>							
Drive Chain Tension (600 H.O. SDI)	A		A			A	
Countershaft Lubrication (2) (600 H.O. SDI)	L		L			L	
Chaincase Oil (600 H.O. SDI)	I		I			R	I
Gearbox Oil (V-1000)	R		I		R		I
Drive Axle End Bearing (2)	L		L			L	
<b>STEERING/SUSPENSION</b>							
Steering and Front Suspension Mechanism (2)	A,I,L		A,I	L		A,I,L	
Wear and Condition of Skis and Runners	I	I				I	
Suspension Adjustments	AS REQUIRED						
Suspension (2)	I		I,L			I,L	
Suspension Stopper Strap				I		I	
Track	I		I			I	
Track Tension and Alignment	A	AS REQUIRED					

<b>PERIODIC MAINTENANCE CHART</b>	(1)	(2)	(3)	(4)	(5)	(6)	(7)
<b>ELECTRICAL</b>							
EMS Fault Codes (3)	I				I		
Spark Plugs (1) (3)	I		I				R
Battery	I		I			I	I
Headlamp Beam Aiming				A			A
Wiring Harnesses, Cables and Lines	I		I			I	
Operation of Lighting System (HI/LO beam, brake light, etc.), Test Operation of Engine Cut-Out Switch and Tether Cut-Out Switch	I	I				I	
<b>BODY/FRAME</b>							
Rags in Air Intake and Exhaust System						R	C
Engine Compartment	C		C			C	
Vehicle Cleaning and Protection	C		C			C	

A = ADJUST

I = INSPECT (adjust, clean, inspect, lubricate and repair)

L = LUBRICATE

R = REPLACE

C = CLEAN

- (1) Before installing new spark plugs at pre-season preparation, it is suggested to burn excess storage oil by starting the engine with the old spark plugs. Only perform this operation in a well ventilated area.
- (2) Lubricate whenever the vehicle is used in wet conditions (wet snow, rain, puddles).
- (3) Emission-related.

---

## FLUID LEVELS

### **WARNING**

It is recommended that the assistance of an authorized SKI-DOO dealer be periodically obtained on other components/systems not covered in this guide. Unless otherwise specified, engine must be cold and not running. Remove tether cord cap before performing any maintenance or adjustment, unless otherwise specified. Vehicle must be parked in a safe place, away from the trail.

**CAUTION:** Vehicle must be on a level surface before checking any fluid levels.

### **Chaincase/Gearbox Oil Level**

With snowmobile on a level surface, check the oil level by removing dipstick. Oil level must be between lower and upper marks.

**NOTE:** It is normal to find metallic particles stuck to dipstick magnet. If bigger pieces of metal are found, see an authorized SKI-DOO dealer.

Remove metal particles from magnet.

Refill up to upper mark using recommended oil, refer to SPECIFICATIONS.

**CAUTION:** Do not use other unrecommended types of oil when servicing. Do not mix synthetic oil with other types of oil.

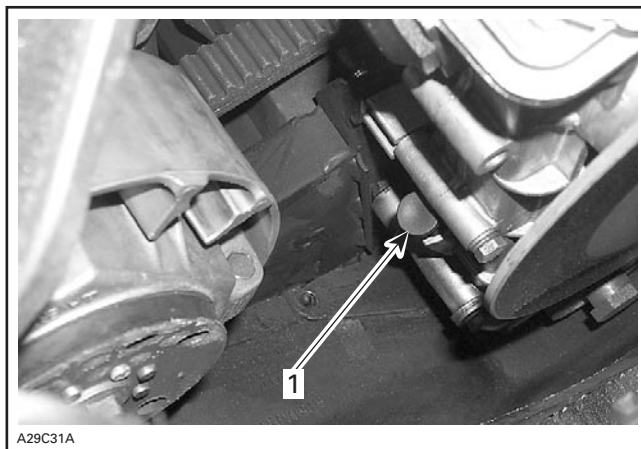

A29C31A

*TYPICAL*

1. Dipstick

## Oil Injection System

### **600 H.O. SDI**

Always maintain a sufficient amount of recommended injection oil in the injection oil reservoir.

**CAUTION:** Never allow oil reservoir to be almost empty. Do not mismatch oil reservoir cap with fuel tank cap. Install cap that is identified OIL.

## **WARNING**

Check level and refill every time you refuel. Be careful not to overfill. Wipe off any spillage. Oil is highly inflammable when heated.





1. Injection oil reservoir

## **Engine Oil Level**

### **V-1000**

Make sure engine is at operating temperature.

Snowmobile must be on a level surface.

Leave engine running at idle for 30 seconds.

Stop engine and wipe the dipstick.

Dipstick must be completely screwed in before checking oil level.

Oil level must be between minimum and maximum marks on dipstick.

There is a capacity of 500 mL (17 U.S. oz) between the two marks.

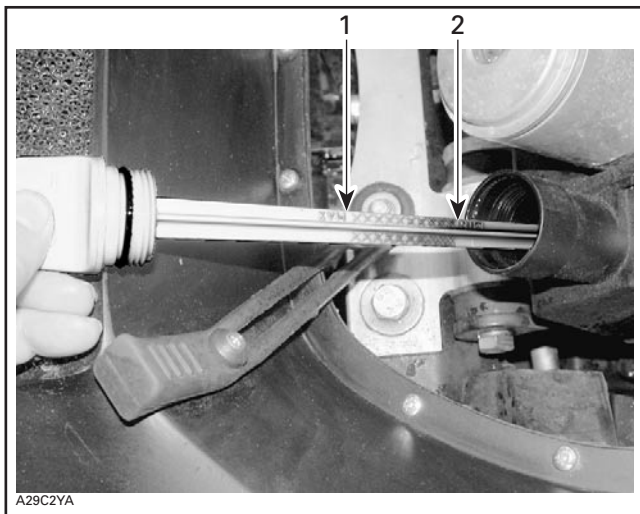

1. *Maximum*
2. *Minimum*

Add XP-S 0W40 synthetic 4-stroke oil (P/N 293 600 054) or an equivalent through dipstick hole as required.

Reinstall dipstick.

## **Cooling System**

Check coolant level in expansion reservoir. When the engine is cold, the level must be between minimum and maximum marks.



A29C33A

**600 H.O. SDI — EXPANSION RESERVOIR NEAR INJECTION OIL RESERVOIR**  
1. Maximum

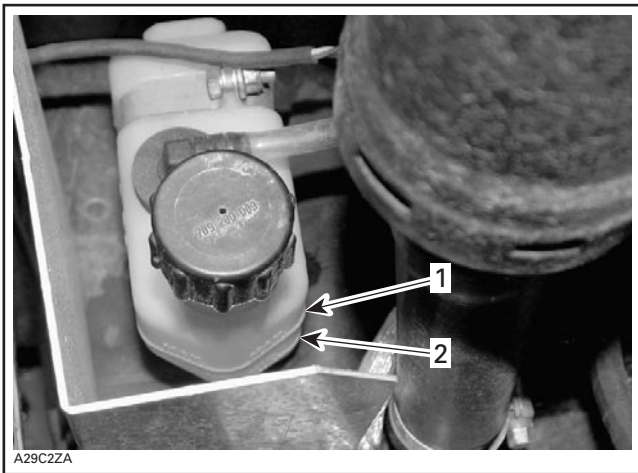

A29C2ZA

**V-1000 — EXPANSION RESERVOIR NEAR MUFFLER**  
1. Maximum  
2. Minimum

## Battery Electrolyte

The Skandic Expedition is equipped with a maintenance-free battery. Electrolyte level can not be checked.



### WARNING

Battery BLACK negative cable must always be disconnected first and connected last.



### WARNING

Never charge or boost battery while installed. Battery electrolyte contains sulfuric acid which is corrosive and poisonous. In case of contact with skin, flush with water and call a physician immediately.



### WARNING

Should the battery casing be damaged, wear a suitable pair of non-absorbent gloves when removing the battery by hand.

**CAUTION:** Should any electrolyte spillage occur, immediately wash off with a solution of baking soda and water to prevent damage to vehicle components.

---

# MAINTENANCE FOR EPA CERTIFIED ENGINES

Maintenance, replacement, or repair of the emission control devices and systems may be performed by any snowmobile SI (spark ignition) engine repair establishments or individual.

## Engine Emissions Information

### Manufacturer's Responsibility

Beginning with 2005 model year engines, snowmobile manufacturers of snowmobile engines may determine the exhaust emission levels for each engine horsepower family and certify these engines with the United States of America Environmental Protection Agency (EPA). An emissions control information label, showing emission levels and engine specifications, must be placed on each vehicle at the time of manufacture.

Bombardier Recreational Products Inc. (BRP) certified the following engine to applicable EPA snowmobile standards:

- 4-TEC V-1000
- 600 H.O. SDI

### Dealer's Responsibility

When performing service on all 2005 and more recent certified SKI-DOO snowmobiles that carry an emissions control information label, adjustments must be kept within published factory specifications.

Replacement or repair of any emission related component must be executed in a manner that maintains emission levels within the prescribed certification standards.

Dealers are not to modify the engine in any manner that would alter the horsepower or allow emission levels to exceed their predetermined factory specifications.

Exceptions include manufacturer's prescribed changes, such as altitude adjustments for example.

### Owner Responsibility

The owner/operator is required to have engine maintenance performed to maintain emission levels within prescribed certification standards.

The owner/operator is not to, and should not allow anyone to modify the engine in any manner that would alter the horsepower or allow emissions levels to exceed their predetermined factory specifications.

## **EPA Emission Regulations**

All new 2005 and more recent certified SKI-DOO snowmobiles manufactured by BRP are certified to the EPA as conforming to the requirements of the regulations for the control of air pollution from new snowmobile engines. This certification is contingent on certain adjustments being set to factory standards. For this reason, the factory procedure for servicing the product must be strictly followed and, whenever practicable, returned to the original intent of the design.

The responsibilities listed above are general and in no way a complete listing of the rules and regulations pertaining to the EPA requirements on exhaust emissions for snowmobile products. For more detailed information on this subject, you may contact the following locations:

### **VIA U.S. POSTAL SERVICE:**

Office of Mobile Sources  
Engine Programs and Compliance Division  
Engine Compliance Programs  
Group (6403J)  
401 M St. NW  
Washington, DC 20460

### **VIA EXPRESS or COURIER MAIL:**

Office of Mobile Sources  
Engine Programs and Compliance Division  
Engine Compliance Programs  
Group (6403J)  
501 3<sup>rd</sup> St. NW  
Washington, DC 20001

### **EPA INTERNET WEB SITE:**

[www.epa.gov](http://www.epa.gov)

---

## MAINTENANCE

### **WARNING**

It is recommended that the assistance of an authorized SKI-DOO dealer be periodically obtained on other components/systems not covered in this guide. Unless otherwise specified, engine must not be running and cold. Remove tether cord cap before performing any maintenance or adjustment, unless otherwise specified. Vehicle must be parked in a safe place, away from the trail.

## Belt Guard Removal and Installation

### **WARNING**

**NEVER** operate engine:

- without shields and belt guard securely installed
- with hood opened or removed.

**NEVER** attempt to make adjustments to moving parts while engine is running.

**NOTE:** Belt guard is purposely made slightly oversize to maintain tension on its pins and retainers preventing undue noise and vibration. It is important that this tension be maintained when reinstalling.

- Remove tether cord cap. Open engine compartment.
- Loosen collar screw on air silencer grommet.
- Disconnect engine vent hose from air silencer.
- Disconnect air temperature sensor.
- Unhook latch from air silencer. Remove air silencer.

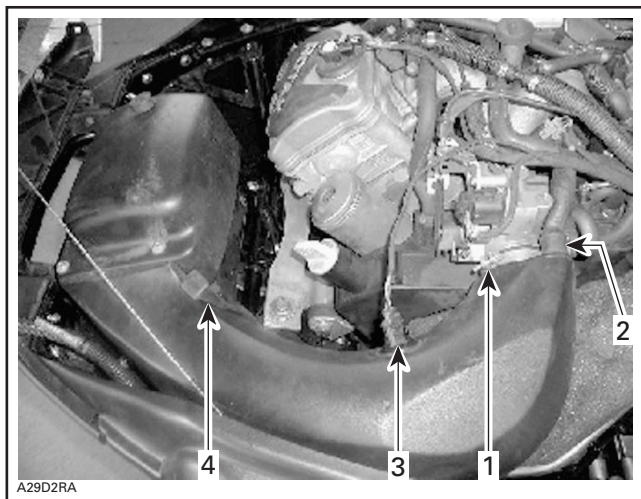

1. Collar screw
2. Vent hose
3. Air temperature sensor
4. Latch

– Refer to *Tundra Skandic Series Operator's Guide* (P/N 520 000 477) and follow Skandic SUV 600 procedure to remove belt guard.

At installation do not forget to connect air temperature sensor otherwise a trouble code will appear.

## Air Filter Cleaning

Check that the air silencer is clean and dry and properly reinstall the filter.

**CAUTION:** Snowmobile engines have been calibrated with the filters installed. Operating the snowmobile without them may cause engine damage.



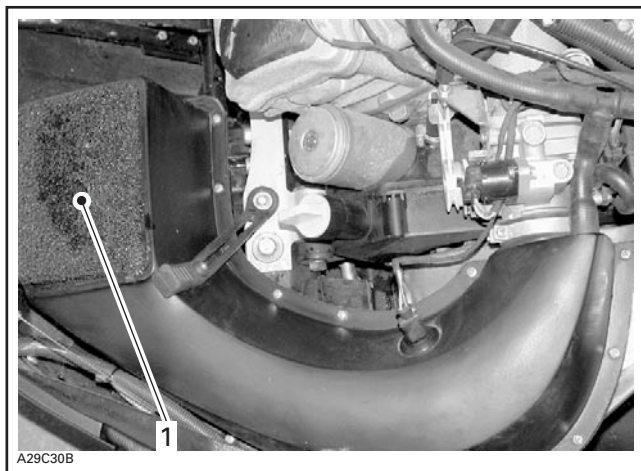

A29C30B

1. Air filter

## Drive Pulley Adjustment

### **WARNING**

Remove tether cord cap before performing any maintenance or adjustment, unless otherwise specified. Vehicle must be parked in a safe place, away from the trail.

### General

From factory TRA drive pulley adjustment screws are set to different positions depending vehicle and its engine type. This position allows the best compromise between acceleration, top speed and fuel economy. Refer to the following table to know the position for your model.

MODELS	POSITION
600 H.O. SDI	3
V-1000	3

Decrease the position would provide the best fuel economy. Top speed would be reduced.

Increase the position would give the best acceleration. Fuel economy would be reduced.

## Adjustment

Just loosen locking nut enough to pull calibration screw **partially** out and adjust to desired position. Do not completely remove the locking nut. Torque locking nuts to 10 N•m (89 lbf•in).

**CAUTION:** Do not completely remove calibration screw otherwise inside washer will fall off. Always adjust all 3 calibration screws and make sure they are all set at the same number.

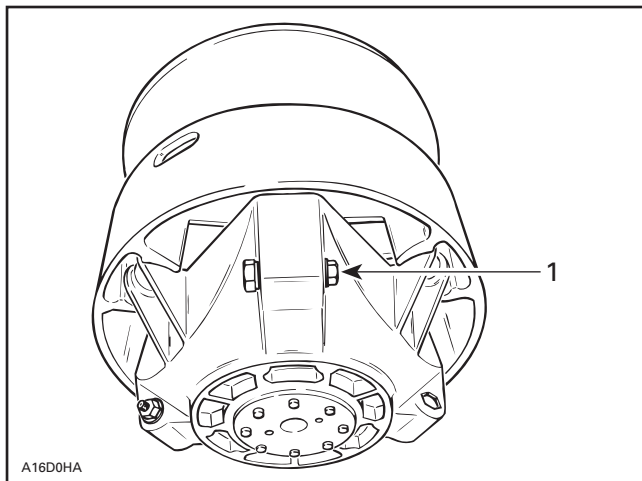

### TYPICAL

1. Loosen just enough to permit rotating of calibrate screw

## WARNING

NEVER disassemble or modify the drive pulley. Improper assembly or modifications could cause the pulley to explode violently under the stress generated by the high rotational speed. This could lead to serious injury including the possibility of death.

See your SKI-DOO dealer to maintain or service the drive pulley. Improper servicing or maintenance may affect performance and reduce belt life. Always respect maintenance schedules.

---

# TROUBLESHOOTING

## Monitoring Beeper Coded Signals

**2 short beeps (when engine is started).**

**DESS/RER pilot lamp also blinks.**

---

1. Confirms that proper tether cord cap is installed. Engine can rev above pulley engagement.

— *Normal condition.*

**1 short beep every 1.5 seconds (when engine is started).  
DESS/RER pilot lamp also blinks.**

**Engine cannot reach pulley engagement speed. Vehicle cannot be driven.**

---

1. Bad DESS system connection.

— *Reinstall tether cord cap correctly over post.*

2. Defective tether cord cap.

— *Use another programmed tether cord cap.*

3. Dirt or snow in tether cord cap.

— *Clean tether cord cap.*

4. Defective DESS post.

— *Replace DESS post.*

**1 long beep per second.**

---

1. Reverse is selected.

— *Vehicle can be driven in reverse.*

**3 short beeps per second. DESS/RER pilot lamp also blinks.**

**Engine cannot reach pulley engagement speed. Vehicle cannot be driven.**

---

1. Wrong tether cord cap is installed.

— *Install proper tether cord cap. Program key into electronic module.*

**3 short beeps per second. Engine overheating pilot lamp also blinks.**

---

1. Engine is overheating.

— *Stop engine immediately and allow to cool. Check cooling system.*

### **3 short beeps per second. Oil pilot lamp also lights up.**

1. Low oil pressure on 4-TEC models.
  - *Stop engine immediately and check oil level and top it. Check lubrication system.*

### **3 short beeps per second.**

1. Low battery voltage.
  - *Check battery and charging system.*

### **4 short beeps every 2 minutes. Oil pilot lamp also lights up.**

1. Low oil level on 2-TEC models.
  - *Check oil level and replenish as soon as possible.*

### **Battery pilot lamp lights up.**

1. No charging.
  - *Check battery and charging system.*

# SPECIFICATIONS

MODEL		SKANDIC EXPEDITION	
		600 H.O. SDI	V-1000
<b>ENGINE</b>			
Type	593-Rotax, 2-TEC		1004-Rotax, 4-TEC
Number of cylinder	2		
Displacement	594.40 cc (60.774 cu. in.)		995.90 cc (60.774 cu. in.)
Bore	72 mm (2.83 in)		100 mm (3.937 in)
Stroke	73 mm (2.87 in)		63.40 mm (2.496 in)
Maximum power engine speed	± 100 RPM	7900	7250
<b>DRIVE BELT</b>			
Part number	605 348 425		
Wear limit width	mm (in)	35.5 (1.398)	
<b>ELECTRICAL</b>			
Magneto/Alternator	Type	480 W	
Spark plug	Make	NGK	
	Number	2	
	Type	BR9ECS	DCPR8E
	Gap	0.75 to 0.85 mm (.026 to .036 in)	
Headlamp bulb	60/55		
Taillight bulb	8/27		
Fuses	Starter solenoid	30 A	
	Fuel level sensor	0.25 A	
	Starting System	20 A (includes electric power outlet)	
<b>SUSPENSION</b>			
Front	Type	SUV trailing arm	
	Travel	200 mm (8 in)	
Rear	Type	SUV type	
	Travel	290 mm (11.5 in)	

MODEL		SKANDIC EXPEDITION	
		600 H.O. SDI	V-1000
<b>TRACK</b>			
Tension	mm (in)	40 - 50 (1-9/16 - 1-31/32) (1)	
Alignment		(2)	
<b>DIMENSION</b>			
Dry mass		310 kg (683 lb)	342 kg (754 lb)
Overall length		3.06 m (120.5 in)	
Overall width		1.22 m (48 in)	
<b>LIQUIDS and GREASES</b>			
Engine oil		(5)	(6)
Coolant		(8)	
Fuel	Type	Premium unleaded gasoline	Regular unleaded gasoline
	Octane	(4)	(3)
Chaincase/Gearbox		(7)	
Brake		DOT 4 (9)	
<b>CAPACITY</b>			
Engine oil	Engine	N.A.	3.4 L (115 U.S. oz)
	Reservoir	2.5 L (84.5 U.S. oz)	N.A.
Coolant		4.5 L (15.2 U.S. oz)	
Fuel tank		42 L (11 U.S. gal)	
Chaincase/Gearbox oil		400 mL (13.5 U.S. oz)	
Brake Fluid		500 mL (17 U.S. oz)	
(1) to (9) and N.A.: See at end of specifications. Because of its ongoing commitment to product quality and innovation, BRP reserves the right, at any time, to make changes in design and specifications and/or to make additions to, or improvements in its products without imposing any obligation upon itself to install them on its products previously manufactured.			

- (1) Measure gap between slider shoe and bottom inside of track when exerting a downward pull of 7.3 kg (16 lb) to the track.
- (2) Equal distance between edges of track guides and slider shoes.
- (3) 87 (R + M)/2 Inside North America or 91 RON Outside North America.
- (4) 91 (R + M)/2 Inside North America or 95 RON Outside North America.
- (5) XP-ST<sup>TM</sup> synthetic 2-stroke oil or XP-ST<sup>TM</sup> 2-stroke synthetic blend oil.
- (6) XP-ST<sup>TM</sup> 0W40 synthetic 4-stroke oil (P/N 293 600 054) or an equivalent).
- (7) XP-ST<sup>TM</sup> synthetic chaincase oil (P/N 413 803 300) or an equivalent.
- (8) Premixed coolant (P/N 219 700 362) or ethylene-glycol/water mix (50% coolant, 50% distilled water).
- (9) SRF (DOT 4) (P/N 293 600 063) or GTLMA (DOT 4) (P/N 293 600 062) or an equivalent.

N.A.: Not Applicable

# ***WARRANTY***



---

# **BRP LIMITED WARRANTY NORTH AMERICA: 2005 SKI-DOO® SNOWMOBILES**

## **1. SCOPE OF THE LIMITED WARRANTY**

Bombardier Recreational Products Inc. ("BRP")\* warrants its 2005 Ski-Doo snowmobiles from defects in material or workmanship for the period and under the conditions described below.

All genuine Ski-Doo parts and accessories, installed by an authorized BRP dealer (as hereinafter defined) at the time of delivery of the 2005 Ski-Doo snowmobile, carry the same warranty as that of the snowmobile.

A GPS receiver may be supplied by BRP as standard equipment on certain 2005 Ski-Doo snowmobiles. The GPS receiver is covered by the limited warranty issued by the GPS receiver's manufacturer and is not covered by this BRP limited warranty.

Use of the product for racing or any other competitive activity, at any point, even by a previous owner, will render this warranty null and void.

## **2. WARRANTY COVERAGE PERIOD**

This warranty will be in effect from the date of delivery to the first retail consumer or the date the product is first put into use, whichever occurs first and for a period of:

TWELVE (12) CONSECUTIVE MONTHS, for private or commercial use owners. However, the warranty coverage period on a snowmobile delivered between June 1<sup>st</sup> and December 1<sup>st</sup> of a given year will expire December 1<sup>st</sup> of the following year.

The emission-related components included in the chart below, that are installed on EPA certified snowmobiles (see list below) registered in the USA are covered for thirty (30) consecutive months or 2500 miles (4000 km) of engine use whichever occurs first. If the 2500 miles (4000 km) are reached during the regular warranty coverage period, the emission-related components are still covered by BRP's standard warranty until the end of regular coverage period.

The EPA certified snowmobiles are those equipped with: 600 HO SDI and 4-TEC V-1000.

EMISSION-RELATED COMPONENTS	600 HO SDI	4-TEC V-1000
Throttle Position Sensor (TPS)	X	X
Air Temperature Sensor (ATS)	X	X
Air Pressure Sensor (APS)	X	X
Fuel Pressure Regulator	X	X
Fuel Injectors	X	X
Engine Management System (EMS)	X	X
Cylinder Head Rubber Rings/O-Ring or Gasket	X	X
Cylinder/Base Gaskets	X	
Throttle Body Shaft Seals	X	
RAVE Hose System	X	
Exhaust System Sealing Components	X	
Knock Sensor	X	
Muffler Temperature Sensor	X	
Crankcase Ventilation System		X

The repair or replacement of parts or the performance of service under this warranty does not extend the life of this warranty beyond its original expiration date.

### **3. CONDITIONS TO HAVE WARRANTY COVERAGE**

This warranty coverage is available only on 2005 Ski-Doo snowmobile purchased as new and unused by its first owner from a BRP dealer authorized to distribute Ski-Doo products in the country in which the sale occurred ("BRP dealer"), and then only after the BRP specified pre-delivery inspection process is completed and documented. Warranty coverage only becomes available upon proper registration of the product by an authorized BRP dealer. Moreover, this warranty coverage is only available if the Ski-Doo snowmobile is purchased in the country in which the purchaser resides. BRP will not honor this limited warranty to any private use owner or commercial use owner if the preceding conditions have not been met. Such limitations are necessary in order to allow BRP to preserve both the safety of its products, and also that of its consumers and the general public.

Routine maintenance outlined in the *Operator's Guide* must be timely performed in order to maintain warranty coverage. BRP reserves the right to make warranty coverage contingent upon proof of proper maintenance.

### **4. WHAT TO DO TO OBTAIN WARRANTY COVERAGE**

The customer must notify a servicing BRP dealer within two (2) days of the appearance of a defect, and provide it with reasonable access to the product and reasonable opportunity to repair it. The customer must also present to the authorized BRP dealer, proof of purchase of the product and must sign the repair/work order prior to starting the repair in order to validate the warranty repair. All parts replaced under this limited warranty become the property of BRP.

### **5. WHAT BRP WILL DO**

BRP's obligations under this warranty are limited to, at its sole discretion, repairing parts found defective under normal use, maintenance and service, or replacing such parts with new genuine Ski-Doo parts without charge for parts and labor, at any authorized BRP dealer during the warranty coverage period.

BRP reserves the right to improve or modify products from time to time without assuming any obligation to modify products previously manufactured.

## 6. EXCLUSIONS

The following are not warranted under any circumstances:

- Normal wear and tear;
- Routine maintenance items, tune ups, adjustments;
- Damage caused by failure to provide proper maintenance and/or storage, as described in the *Operator's Guide*;
- Damage resulting from removal of parts, improper repairs, service, maintenance, modifications or use of parts not manufactured or approved by BRP or resulting from repairs done by a person that is not an authorized servicing BRP dealer;
- Damage caused by abuse, abnormal use, neglect, use of the product on surfaces other than snow, or operation of the product in a manner inconsistent with the recommended operation described in the *Operator's Guide*;
- Damage resulting from accident, submersion, fire, theft, vandalism or any act of God;
- Operation with fuels, oils or lubricants which are not suitable for use with the product (see the *Operator's Guide*);
- Snow or water ingestion;
- Incidental or consequential damages, or damages of any kind including without limitation towing, storage, telephone, rental, taxi, inconvenience, insurance coverage, loan payments, loss of time, loss of income; and
- Damage resulting from studs installed on tracks if the installation does not conform to BRP's instructions.

## 7. LIMITATIONS OF LIABILITY

THIS WARRANTY IS EXPRESSLY GIVEN AND ACCEPTED IN LIEU OF ANY AND ALL OTHER WARRANTIES, EXPRESSED OR IMPLIED, INCLUDING WITHOUT LIMITATION ANY WARRANTY OF MERCHANTABILITY OR FITNESS FOR A PARTICULAR PURPOSE. TO THE EXTENT THAT THEY CANNOT BE DISCLAIMED, THE IMPLIED WARRANTIES ARE LIMITED IN DURATION TO THE LIFE OF THE EXPRESS WARRANTY. INCIDENTAL AND CONSEQUENTIAL DAMAGES ARE EXCLUDED FROM COVERAGE UNDER THIS WARRANTY. SOME STATES/PROVINCES DO NOT ALLOW FOR THE DISCLAIMERS, LIMITATIONS AND EXCLUSIONS IDENTIFIED ABOVE, AS A RESULT, THEY MAY NOT APPLY TO YOU. THIS WARRANTY GIVES YOU SPECIFIC RIGHTS, AND YOU MAY ALSO HAVE OTHER LEGAL RIGHTS WHICH MAY VARY FROM STATE TO STATE, OR PROVINCE TO PROVINCE.

Neither the distributor, any BRP dealer nor any other person has been authorized to make any affirmation, representation or warranty regarding the product, other than those contained in this limited warranty, and if made, shall not be enforceable against BRP.

BRP reserves the right to modify this warranty at any time, being understood that such modification will not alter the warranty conditions applicable to the products sold while this warranty is in effect.

## **8. TRANSFER**

If the ownership of a product is transferred during the warranty coverage period, this warranty shall also be transferred and be valid for the remaining coverage period provided that BRP is notified of such transfer of ownership in the following way:

- a) The former owner contacts BRP (at the phone number provided below) or an authorized BRP dealer and gives the coordinates of the new owner; or
- b) BRP or an authorized BRP dealer receives a proof that the former owner agreed to the transfer of ownership, in addition to the coordinates of the new owner.

## **9. CONSUMER ASSISTANCE**

- a) In the event of a controversy or a dispute in connection with this limited warranty, BRP suggests that you try to resolve the issue at the dealership level. We recommend discussing the issue with the authorized dealer's service manager or owner.
- b) If the issue has not yet been resolved, please submit your complaint in writing or call the appropriate number below:

In Canada:

**BOMBARDIER**  
**RECREATIONAL PRODUCTS INC.**  
SKI-DOO  
CONSUMER SERVICES GROUP  
VALCOURT QC J0E 2L0  
Tel: (819) 566-3366

In USA:

**BRP US INC.**  
SKI-DOO  
CONSUMER SERVICES GROUP  
7575 BOMBARDIER COURT  
WAUSAU WI 54401  
Tel: (715) 848-4957

\* In the USA, products are distributed and serviced by BRP US Inc.  
© 2004 Bombardier Recreational Products Inc. All rights reserved.  
® Registered trademark of Bombardier Recreational Products Inc.

---

# **BRP INTERNATIONAL LIMITED WARRANTY: 2005 SKI-DOO® SNOWMOBILES**

## **1. SCOPE OF THE LIMITED WARRANTY**

Bombardier Recreational Products Inc. ("BRP") warrants its 2005 Ski-Doo snowmobiles from defects in material or workmanship for the period and under the conditions described below.

All genuine Ski-Doo parts and accessories, installed by an authorized BRP distributor/dealer (as hereinafter defined) at the time of delivery of the 2005 Ski-Doo snowmobile, carry the same warranty as that of the snowmobile.

Use of the product for racing or any other competitive activity, at any point, even by a previous owner, will render this warranty null and void.

## **2. WARRANTY COVERAGE PERIOD**

This warranty will be in effect from the date of delivery to the first retail consumer or the date the product is first put into use, whichever occurs first and for a period of:

TWELVE (12) CONSECUTIVE MONTHS, for private or commercial use owners. However, the warranty coverage period on a snowmobile delivered between June 1<sup>st</sup> and December 1<sup>st</sup> of a given year will expire December 1<sup>st</sup> of the following year.

The repair or replacement of parts or the performance of service under this warranty does not extend the life of this warranty beyond its original expiration date.

## **3. CONDITIONS TO HAVE WARRANTY COVERAGE**

This warranty coverage is available only on 2005 Ski-Doo snowmobile purchased as new and unused by its first owner from a BRP distributor/dealer authorized to distribute Ski-Doo products in the country in which the sale occurred ("BRP distributor/dealer"), and then only after the BRP specified pre-delivery inspection process is completed and documented. Warranty coverage only becomes available upon proper registration of the product by an authorized BRP distributor/dealer. Moreover, this warranty coverage is only available if the Ski-doo snowmobile is purchased in the country or union of countries in which the purchaser resides. BRP will not honor this limited warranty to any private use owner or commercial use owner if the preceding conditions have not been met. Such limitations are necessary in order to allow BRP to preserve both the safety of its products, and also that of its consumers and the general public.

Routine maintenance outlined in the *Operator's Guide* must be timely performed in order to maintain warranty coverage. BRP reserves the right to make warranty coverage contingent upon proof of proper maintenance.

## **4. WHAT TO DO TO OBTAIN WARRANTY COVERAGE**

The customer must notify a servicing BRP distributor/dealer within two (2) days of the appearance of a defect, and provide it with reasonable access to the product and reasonable opportunity to repair it. The customer must also present to the authorized BRP distributor/dealer, proof of purchase of the product and must sign the repair/work order prior to starting the repair in order to validate the warranty repair. All parts replaced under this limited warranty become the property of BRP.

## **5. WHAT BRP WILL DO**

BRP's obligations under this warranty are limited to, at its sole discretion, repairing parts found defective under normal use, maintenance and service, or replacing such parts with new genuine Ski-Doo parts without charge for parts and labor, at any authorized BRP distributor/dealer during the warranty coverage period.

BRP reserves the right to improve or modify products from time to time without assuming any obligation to modify products previously manufactured.

## **6. EXCLUSIONS**

The following are not warranted under any circumstances:

- Normal wear and tear;
- Routine maintenance items, tune ups, adjustments;
- Damage caused by failure to provide proper maintenance and/or storage, as described in the *Operator's Guide*;
- Damage resulting from removal of parts, improper repairs, service, maintenance, modifications or use of parts not manufactured or approved by BRP or resulting from repairs done by a person that is not an authorized servicing BRP distributor/dealer;
- Damage caused by abuse, abnormal use, neglect, use of the product on surfaces other than snow, or operation of the product in a manner inconsistent with the recommended operation described in the *Operator's Guide*;
- Damage resulting from accident, submersion, fire, theft, vandalism or any act of God;



- Operation with fuels, oils or lubricants which are not suitable for use with the product (see the *Operator's Guide*);
- Snow or water ingestion;
- Incidental or consequential damages, or damages of any kind including without limitation towing, storage, telephone, rental, taxi, inconvenience, insurance coverage, loan payments, loss of time, loss of income; and
- Damage resulting from studs installed on tracks if the installation does not conform to BRP's instructions.

## **7. LIMITATIONS OF LIABILITY**

THIS WARRANTY IS EXPRESSLY GIVEN AND ACCEPTED IN LIEU OF ANY AND ALL OTHER WARRANTIES, EXPRESSED OR IMPLIED, INCLUDING WITHOUT LIMITATION ANY WARRANTY OF MERCHANTABILITY OR FITNESS FOR A PARTICULAR PURPOSE. TO THE EXTENT THAT THEY CANNOT BE DISCLAIMED, THE IMPLIED WARRANTIES ARE LIMITED IN DURATION TO THE LIFE OF THE EXPRESS WARRANTY. INCIDENTAL AND CONSEQUENTIAL DAMAGES ARE EXCLUDED FROM COVERAGE UNDER THIS WARRANTY. SOME STATES/PROVINCES DO NOT ALLOW FOR THE DISCLAIMERS, LIMITATIONS AND EXCLUSIONS IDENTIFIED ABOVE, AS A RESULT, THEY MAY NOT APPLY TO YOU. THIS WARRANTY GIVES YOU SPECIFIC RIGHTS, AND YOU MAY ALSO HAVE OTHER LEGAL RIGHTS WHICH MAY VARY FROM STATE TO STATE, OR PROVINCE TO PROVINCE.

Neither the distributor, any BRP distributor/dealer nor any other person has been authorized to make any affirmation, representation or warranty regarding the product, other than those contained in this limited warranty, and if made, shall not be enforceable against BRP.

BRP reserves the right to modify this warranty at any time, being understood that such modification will not alter the warranty conditions applicable to the products sold while this warranty is in effect.

## **8. TRANSFER**

If the ownership of a product is transferred during the warranty coverage period, this warranty shall also be transferred and be valid for the remaining coverage period provided BRP or an authorized BRP distributor/dealer receives a proof that the former owner agreed to the transfer of ownership, in addition to the co-ordinates of the new owner.

## **9. CONSUMER ASSISTANCE**

- a) In the event of a controversy or a dispute in connection with this limited warranty, BRP suggests that you try to resolve the issue at the dealership level. We recommend discussing the issue with the authorized distributor/dealer's service manager or owner.
- b) If further assistance is required, the distributor's service department should be contacted in order to resolve the matter.
- c) If the matter still remains unresolved then contact BRP by writing to us at the address listed below.

**BOMBARDIER  
RECREATIONAL PRODUCTS INC.**

SKI-DOO  
CONSUMER SERVICES GROUP  
VALCOURT QC J0E 2L0  
Canada  
Tel: (819) 566-3366

© 2004 Bombardier Recreational Products Inc. All rights reserved.

® Registered trademark of Bombardier Recreational Products Inc.

---

## **PRIVACY OBLIGATIONS/DISCLAIMER**

We wish to inform you that your coordinates will be used for safety and warranty purposes. Sometimes, we also use the coordinates of our clients to inform them about our products and to present them offers. Should you prefer not to receive information on our products, services and offers, please let us know by writing to the address below.

Also note that, from time to time, carefully selected and trustworthy organizations may be permitted to use the coordinates of our clients to promote quality products and services. If you prefer not to have your name and address released, please let us know by writing to the address below:

### **Bombardier Recreational Products Inc.**

Warranty Department  
75, J.A. Bombardier Street  
Sherbrooke, Québec J1L 1W3  
Canada

Fax Number: (819) 566-3590

---

## **CHANGE OF ADDRESS OR OWNERSHIP**

If your address has changed or if you are the new owner of the snowmobile, be sure to notify BRP by either:

- mailing the card below;
- calling at (715) 848-4957 (USA) or (819) 566-3366 (Canada);
- notifying an authorized SKI-DOO distributor/dealer.

In case of change of ownership, please join a proof that the former owner agreed to the transfer.

Notifying BRP, even after the expiration of the limited warranty, is very important as it enables BRP to reach the snowmobile owner if necessary, like when safety recalls are initiated. It is the owner's responsibility to notify BRP.

**STOLEN UNITS:** If your snowmobile is stolen, you should notify BRP or an authorized SKI-DOO distributor/dealer. We will ask you to provide your name, address, phone number, the vehicle identification number and the date it was stolen.



**CHANGE OF ADDRESS**

**CHANGE OF OWNERSHIP**

VEHICLE IDENTIFICATION NUMBER

--	--	--	--	--	--	--	--	--	--	--	--	--	--	--	--	--	--	--	--	--

OLD ADDRESS  
OR PREVIOUS OWNER

NAME

NO.

STREET

APT.

CITY

STATE/PROVINCE

ZIP/POSTAL CODE

NEW ADDRESS  
OR NEW OWNER

NAME

NO.

STREET

APT.

CITY

STATE/PROVINCE

ZIP/POSTAL CODE

A00A81

AFFIX  
PROPER  
POSTAGE

**Bombardier  
Recreational Products Inc.**

WARRANTY DEPARTMENT  
75, J.A. Bombardier  
Sherbrooke, QC  
Canada  
J1L 1W3



**CHANGE OF ADDRESS**

**CHANGE OF OWNERSHIP**

**VEHICLE IDENTIFICATION NUMBER**

--	--	--	--	--	--	--	--	--	--	--	--	--	--	--	--	--	--	--	--	--

**OLD ADDRESS  
OR PREVIOUS OWNER**

NAME

NO.

STREET

APT.

CITY

STATE/PROVINCE

ZIP/POSTAL CODE

**NEW ADDRESS  
OR NEW OWNER**

NAME

NO.

STREET

APT.

CITY

STATE/PROVINCE

ZIP/POSTAL CODE

AFFIX  
PROPER  
POSTAGE

**Bombardier  
Recreational Products Inc.**

WARRANTY DEPARTMENT  
75, J.A. Bombardier  
Sherbrooke, QC  
Canada  
J1L 1W3